

การออกแบบโครงสร้างการควบคุมของโรงงานไฮโดรดีอัลคิลเลชัน
ที่มีการเบ็ดเสร็จของพลังงาน โดยมีการใช้หม้อต้มซ้ำช่วยน้อยที่สุด



นายบุญเลิศ แซ่เลี้ยว

สถาบันวิทยบริการ

วิทยานิพนธ์นี้เป็นส่วนหนึ่งของการศึกษาตามหลักสูตรปริญญาวิศวกรรมศาสตรมหาบัณฑิต

สาขาวิชาวิศวกรรมเคมี ภาควิชาวิศวกรรมเคมี

คณะวิศวกรรมศาสตร์ จุฬาลงกรณ์มหาวิทยาลัย

ปีการศึกษา 2549

ลิขสิทธิ์ของจุฬาลงกรณ์มหาวิทยาลัย

DESIGN OF CONTROL STRUCTURES OF ENERGY-INTEGRATED
HDA PLANT WITH MINIMUM AUXILIARY REBOILERS



Mr. Boonlert Sae-leaw

สถาบันวิทยบริการ

จุฬาลงกรณ์มหาวิทยาลัย
A Thesis Submitted in Partial Fulfillment of the Requirements
for the Degree of Master of Engineering Program in Chemical Engineering

Department of Chemical Engineering

Faculty of Engineering

Chulalongkorn University

Academic Year 2006

Copyright of Chulalongkorn University

Thesis Title DESIGN OF CONTROL STRUCTURES OF ENERGY-
INTERATED HDA PLANT WITH MINIMUM
AUXILIARY REBOILERS
By Mr. Boonlert Sae-leaw
Field of study Chemical Engineering
Thesis Advisor Assistant Professor Montree Wongsri, D.Sc.
Thesis Co-advisor Assistant Professor Kulchanat Prasertsit, Ph.D.

Accepted by the Faculty of Engineering, Chulalongkorn University in Partial
Fulfillment of the Requirements for the Master's Degree.

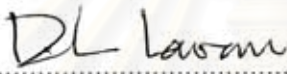

..... Dean of the Faculty of Engineering
(Professor Direk Lavansiri, Ph.D.)

THESIS COMMITTEE

..... Chairman
(Professor Piyasan Praserttham, Dr.Eng.)

..... Thesis Advisor
(Assistant Professor Montree Wongsri, D.Sc.)

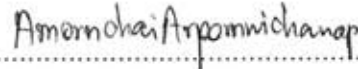
..... Thesis Co-Advisor
(Assistant Professor Kulchanat Prasertsit, Ph.D.)

..... Member
(Amornchai Arpornwichanop, D.Eng)

..... Member
(Phisit Jaisathaporn, Ph.D.)

บุญเลิศ แซ่เลี้ยว : การออกแบบโครงสร้างการควบคุมของโรงงานไฮโดรดีอัลคิลเลชันที่มีการเบ็ดเสร็จของพลังงานโดยมีการใช้หม้อต้มซ้ำช่วยน้อยที่สุด (DESIGN OF CONTROL STRUCTURES OF ENERGY-INTEGRATED HDA PLANT WITH MINIMUM AUXILIARY REBOILERS) อ. ที่ปรึกษา: ผศ. ดร. มนต์รี วงศ์ศรี, อ.ที่ปรึกษาร่วม: ผศ. ดร. กุลชนาฐ ประเสริฐสิทธิ์, 199 หน้า.

การออกแบบโครงสร้างการควบคุมแบบแพลนไวต์สำหรับกระบวนการที่มีการเบ็ดเสร็จของพลังงานเป็นปัญหาที่ค่อนข้างยาก โดยจะต้องออกแบบและทำการดัดแปลงกระบวนการเพื่อรับประกันความสามารถในการควบคุม การปฏิบัติการ และผลกำไรของกระบวนการผลิต ในงานวิจัยนี้ได้ทำการอธิบายถึงวิธีการออกแบบการควบคุมแบบแพลนไวต์ที่ประยุกต์ใช้กับกระบวนการไฮโดรดีอัลคิลเลชัน ซึ่งเป็นกระบวนการที่มีการเบ็ดเสร็จของพลังงาน โดยเริ่มต้นด้วยการกำหนดรายละเอียดและขนาดของตัวรบกวนตามด้วยการออกแบบช่ายงานแลกเปลี่ยนความร้อนแบบยัดหยุนเพื่อรับประกันการดำเนินการได้ของกระบวนการเมื่อมีภาระของตัวรบกวนเกิดขึ้น ช่ายงานดังกล่าวถูกออกแบบภายใต้สภาวะซึ่งสามารถให้ความร้อนได้ต่ำสุดและมีความต้องการรับพลังงานสูงสุด จากวิธีการข้างต้นเราสามารถแก้ปัญหาเกี่ยวกับความยากในการควบคุมกระบวนการไฮโดรดีอัลคิลเลชันได้โดยการเพิ่มจำนวนหม้อต้มซ้ำช่วยในกระบวนการเพียงหนึ่งตัว ในขณะที่ลูเบน (Luyben, 1999) ได้ทำการเพิ่มจำนวนหม้อต้มซ้ำช่วยถึง 3 ตัวด้วยกันเพื่อแก้ปัญหาเดียวกันนี้ นอกจากนี้ในงานวิจัยดังกล่าวยังได้ทำการเสนอโครงสร้างการควบคุมแบบใหม่ขึ้นมาอีก 3 โครงสร้างอีกทั้งยังประเมินสมรรถนะของโครงสร้างดังกล่าวไว้ด้วย โครงสร้างการควบคุมแบบที่ 2 เป็นโครงสร้างที่สามารถรับมือกับภาระของตัวรบกวนได้ดีที่สุด เนื่องจากสมรรถนะการควบคุมของโครงสร้างดังกล่าวดีกว่าโครงสร้างอื่นๆ ในโครงสร้างแบบที่ 2 ได้ทำการควบคุมอัตราการป้อนของรีไซเคิลคอลัมน์ ทั้งนี้เพื่อป้องกันไม่ให้อธิพผลการเปลี่ยนแปลงที่เกิดขึ้นภายในกระบวนการแพร่กระจายไปยังหน่วยปฏิบัติการอื่นๆ

ภาควิชา.....วิศวกรรมเคมี.....
สาขาวิชา.....วิศวกรรมเคมี.....
ปีการศึกษา.....2549.....

ลายมือชื่อนิสิต.....บุญเลิศ แซ่เลี้ยว.....
ลายมือชื่ออาจารย์ที่ปรึกษา.....
ลายมือชื่ออาจารย์ที่ปรึกษาร่วม.....

##4870360221 : MAJOR CHEMICAL ENGINEERING

KEY WORD: HDA PROCESS/PLANTWIDE PROCESS CONTROL/HEAT EXCHANGER NETWORK

BOONLERT SAE-LEAW: DESIGN OF CONTROL STRUCTURES OF ENERGY-INTEGRATED HDA PLANT WITH MINIMUM AUXILIARY REBOILERS. THESIS ADVISOR: ASST. PROF. MONTREE WONGSRI, THESIS COADVISOR: ASST. PROF. KULCHANAT PRASERTSIT, 199 pp.

The problem of design plantwide control structure for a highly heat integrated plant is quite difficult task. It requires design modifications to the process to ensure controllability, operability and profitability. In this research, we outline the plantwide control design approach that would be taken for a complex heat-integrated scheme like Alternative 6 of the HDA process. It starts with specifying the disturbances and their magnitudes, and then designing the resilient heat exchanger network is designed at the minimum heat supply and maximum heat demand condition. We can solve the control difficulties associated with Alternative 6 by adding an auxiliary reboiler to the process instead of three as suggested by Luyben (1999). The three new control structures are proposed and their performances are evaluated. CS2 is the best control structure for handle disturbances due to it gives better control performances. In this control structure, the recycle column feed flow rate is flow-controlled so that fluctuations in the process are not propagated to the next downstream unit operations.

สถาบันวิทยบริการ
จุฬาลงกรณ์มหาวิทยาลัย

Department....Chemical Engineering.....

Field of study....Chemical Engineering....

Academic year.....2006.....

Student's signature.....*Boonlert Sae-leaw*.....

Advisor's signature.....*[Signature]*.....

Co-Advisor's signature.....*[Signature]*.....

ACKNOWLEDGEMENTS

The author would like to thank and express his sincere gratitude to Assistant Professor Montree Wongsri, thesis advisor and Assistant Professor Kulchanat Prasertsit, thesis co-advisor, for valuable suggestions, encouraging guidance and genius supervision throughout his master program. He is grateful to Professor Piyasan Praserttham, chairman of thesis committee, Dr. Amornchai Arpornwichanop and Dr. Phisit Jaisathaporn members of thesis committees for many valuable suggestions.

Many thanks to Chulalongkorn University for financial supporting this work, Department of Chemical Engineering for financial supporting tuition fee and monthly allowance, process control laboratory members, friends and all those who encouraged over the years of his study.

Most of all, he would like to express the highest gratitude to all of family for their love, inspiration, encouragement and financial support throughout this study.



สถาบันวิทยบริการ
จุฬาลงกรณ์มหาวิทยาลัย

CONTENTS

	page
ABSTRACT (IN THAI).....	iv
ABSTRACT (IN ENGLISH).....	v
ACKNOWLEDGEMENTS.....	vi
CONTENTS.....	vii
LIST OF TABLES.....	xii
LIST OF FIGURES.....	xvi
NOMENCLATURES.....	xxiv
CHAPTER	
I INTRODUCTION.....	1
1.1 Background.....	1
1.2 Objective of the Research.....	2
1.3 Scopes of the Research.....	3
1.4 Contributions of the Research.....	3
1.5 Research Procedures.....	3
1.6 Research Framework.....	4
II LITERATURE REVIEW.....	6
2.1 Conceptual Design.....	6
2.2 Heat Exchanger Networks (HENs).....	9
2.3 Design and Control of Energy-Integrated Process.....	14
III PLANTWIDE CONTROL FUNDAMENTALS.....	20
3.1 Incentives for Chemical Process Control.....	20

CHAPTER	page
3.1.1 Suppressing the Influence of External Disturbances.....	20
3.1.2 Ensuring the Stability of a Chemical Process.....	21
3.1.3 Optimizing the Performance of a Chemical Process.....	21
3.2 Integrated Process.....	21
3.2.1 Material recycles.....	21
3.2.2 Energy integration.....	23
3.2.3 Chemical component inventories.....	23
3.3 Effects of Recycle.....	23
3.3.1 Snowball effect.....	24
3.4 Basic Concepts of Plantwide Control.....	24
3.4.1 Buckley basic.....	24
3.4.2 Douglas doctrines.....	24
3.4.3 Downs drill.....	25
3.4.4 Luyben laws.....	26
3.4.5 Richardson rule.....	26
3.4.6 Shinskey schemes.....	26
3.4.7 Tyreus tuning.....	26
3.5 Step of Plantwide Process Control Design Procedure.....	27
3.6 Plantwide Energy Management.....	31
3.6.1 Heat exchanger dynamics.....	31
3.6.2 Heat pathways.....	31
3.6.3 Heat recovery.....	32
3.6.4 Control of utility exchangers.....	33
3.6.5 Control of process-to-process exchangers.....	33

CHAPTER	page
3.7 Heat Exchanger Network.....	34
3.7.1 Definition of HEN resiliency.....	36
3.7.2 Design conditions.....	37
3.7.3 Match Patterns.....	38
IV HDA PROCESS.....	42
4.1 Process Description.....	42
4.2 Plantwide Control Strategies.....	44
4.3 Steady-State Modeling.....	54
V DESIGN OF WORKABLE COMPLEX HEAT-INTEGRATED HDA PROCESS AND STEADY STATE SIMULATION.....	56
5.1 Design of Workable Complex Heat-Integrated HDA Process....	56
5.2 Steady State Simulation.....	57
VI CONTROL STRUCTURES AND DYNAMIC SIMULATION.....	63
6.1 Design of plantwide Control for HDA Process with three Auxiliary Reboilers: Base Case.....	63
6.1.1 Dynamic Simulation Results for HDA Process with three Auxiliary Reboilers: Base Case.....	65
6.2 Design of plantwide Control for HDA Process with three Auxiliary Reboilers: Control Structure 1.....	78
6.2.1 Dynamic Simulation Results for HDA Process with three Auxiliary Reboilers: Control Structure 1.....	78

CHAPTER	page
6.3 Design of plantwide Control for HDA Process with three Auxiliary Reboilers: Control Structure 2.....	82
6.3.1 Dynamic Simulation Results for HDA Process with three Auxiliary Reboilers: Control Structure 2.....	91
6.4 Design of plantwide Control for HDA Process with three Auxiliary Reboilers: Control Structure 3.....	95
6.4.1 Dynamic Simulation Results for HDA Process with three Auxiliary Reboilers: Control Structure 3.....	104
6.5 Design of plantwide Control for HDA Process with Minimum Auxiliary Reboilers: Base Case.....	116
6.5.1 Dynamic Simulation Results for HDA Process with Minimum Auxiliary Reboilers: Base Case.....	117
6.6. Design of plantwide Control for HDA Process with Minimum Auxiliary Reboilers: Control Structure 1.....	121
6.6.1 Dynamic Simulation Results for HDA Process with Minimum Auxiliary Reboilers: Control Structure 1.....	130
6.7. Design of plantwide Control for HDA Process with Minimum Auxiliary Reboilers: Control Structure 2.....	134
6.7.1 Dynamic Simulation Results for HDA Process with Minimum Auxiliary Reboilers: Control Structure 2.....	143
6.8. Design of plantwide Control for HDA Process with Minimum Auxiliary Reboilers: Control Structure 3.....	147
6.8.1 Dynamic Simulation Results for HDA Process with Minimum Auxiliary Reboilers: Control Structure 3.....	156

CHAPTER	page
6.9 Evaluation of the Dynamic Performance.....	160
VII CONCLUSIONS AND RECCOMMENDATIONS.....	171
7.1 Conclusion.....	171
7.1.1 Steady state simulation results.....	171
7.1.2 Dynamic simulation results.....	171
7.1.3 Evaluation of the dynamic performance.....	173
7.2 Recommendations.....	173
REFERENCES.....	174
APPENDICES.....	176
Appendix A.....	177
Appendix B.....	181
Appendix C.....	185
Appendix D.....	193
VITA.....	199

สถาบันวิทยบริการ
จุฬาลงกรณ์มหาวิทยาลัย

LIST OF TABLES

		page
Table 4.1	Process stream data, part 1.....	48
Table 4.2	Process stream data, part 2.....	48
Table 4.3	Process stream data, part 3.....	48
Table 4.4	Process stream data, part 4.....	49
Table 4.5	Equipment data and specifications.....	50
Table 4.6	Heat transfer rates.....	51
Table 4.7	Energy integration for HDA process.....	51
Table 5.1	The changes of the temperature of dependent streams.....	58
Table 5.2	An amount of energy of HDA-6 process at worst case condition.....	58
Table 5.3	The energy rate of furnace, cooler, and auxiliary reboilers..	60
Table 5.4	The capital cost of HDA plants.....	60
Table 6.1	The initial values of controlled and manipulated variables for HDA process with three auxiliary reboilers: Base Case.	70
Table 6.2	The initial values of controlled and manipulated variables for HDA process with three auxiliary reboilers: Control Structure 1.....	83
Table 6.3	The initial values of controlled and manipulated variables for HDA process with three auxiliary reboilers: Control Structure 2.....	96
Table 6.4	The initial values of controlled and manipulated variables for HDA process with three auxiliary reboilers: Control Structure 3.....	109

Table 6.5	The initial values of controlled and manipulated variables for HDA process with minimum auxiliary reboilers: Base Case.....	122
Table 6.6	The initial values of controlled and manipulated variables for HDA process with minimum auxiliary reboilers: Control Structure 1.....	135
Table 6.7	The initial values of controlled and manipulated variables for HDA process with minimum auxiliary reboilers: Control Structure 2.....	148
Table 6.8	The initial values of controlled and manipulated variables for HDA process with minimum auxiliary reboilers: Control Structure 3.....	161
Table 6.9	IAE values of HDA process (alternative 6) with three auxiliary reboilers.....	170
Table 6.10	IAE values of HDA process (alternative 6) with minimum auxiliary reboiler.....	170
Table 7.1	Information of each control structure.....	172
Table A.1	Constant for Bare Module Factor.....	179
Table A.2	Equations for Bare Module Cost for Equipment.....	179
Table B.1	Typical measurement lags.....	184
Table C.1	Parameter tuning of the Base Case of HDA process with three auxiliary reboilers.....	185
Table C.2	Parameter tuning of the CS1 of HDA process with three auxiliary reboilers.....	186

Table C.3	Parameter tuning of the CS2 of HDA process with three auxiliary reboilers.....	187
Table C.4	Parameter tuning of the CS3 of HDA process with three auxiliary reboilers.....	188
Table C.5	Parameter tuning of the Base Case of HDA with minimum auxiliary reboilers.....	189
Table C.6	Parameter tuning of the CS1 of HDA with minimum auxiliary reboilers.....	190
Table C.7	Parameter tuning of the CS2 of HDA with minimum auxiliary reboilers.....	191
Table C.8	Parameter tuning of the CS3 of HDA with minimum auxiliary reboilers.....	192
Table D.1	IAE value for Change in the Disturbance Load of Cold Stream.....	193
Table D.2	IAE value for Change in the Disturbance Load of Cold Stream from the Bottoms of Stabilizer Column.....	194
Table D.3	IAE value for Change in the Disturbance Load of Cold Stream from the Bottoms of Product Column.....	194
Table D.4	IAE value for Change in the Disturbance Load of Cold Stream from the Bottoms of Recycle Column.....	194
Table D.5	IAE value for Change in the Disturbance Load of Hot Stream.....	195
Table D.6	IAE value for Change in the Total Toluene Feed Flowrate.....	195

Table D.7	IAE value for Change in the Disturbance Load of Cold Stream.....	196
Table D.8	IAE value for Change in the Disturbance Load of Cold Stream from the Bottoms of Stabilizer Column.....	196
Table D.9	IAE value for Change in the Disturbance Load of Cold Stream from the Bottoms of Product Column.....	197
Table D.10	IAE value for Change in the Disturbance Load of Cold Stream from the Bottoms of Recycle Column.....	197
Table D.11	IAE value for Change in the Disturbance Load of Hot Stream.....	197
Table D.12	IAE value for Change in the Total Toluene Feed Flowrate.....	198

LIST OF FIGURES

		page
Figure 3.1	Heat pathways.....	32
Figure 3.2	Control of process-to-process heat exchanger using the auxiliary utility.....	35
Figure 3.3	Bypass controls of process-to-process heat exchangers.....	35
Figure 3.4	A viewpoint of worst case condition.....	39
Figure 3.5	Class A Match Pattern.....	41
Figure 3.6	Class B Match Pattern.....	41
Figure 3.7	Class C Match Pattern.....	41
Figure 3.8	Class D Match Pattern.....	41
Figure 4.1	Hydrodealkylation of toluene process (Alternative 1).....	44
Figure 4.2	HDA process (Alternative 1).....	45
Figure 4.3	HDA process (Alternative 2).....	45
Figure 4.4	HDA process (Alternative 3).....	46
Figure 4.5	HDA process (Alternative 4).....	46
Figure 4.6	HDA process (Alternative 5).....	47
Figure 4.7	HDA process (Alternative 6).....	47
Figure 5.1	The Heat Exchanger Network (HEN) of HDA process.....	57
Figure 5.2	Heat Pathways of HDA process(Alternative 6).....	58
Figure 5.3	The resilient Heat Exchanger Network (RHEN) of HDA process (Alternative 6).....	59
Figure 5.4	HYSYS flowsheet of HDA process (Alternative 6) with three auxiliary reboilers.....	61

Figure 5.5	HYSYS flowsheet of HDA process (Alternative 6) with minimum auxiliary reboiler.....	62
Figure 6.1	Base Case control structure of the HDA process with three auxiliary reboilers.....	71
Figure 6.2	Dynamic responses of Base Case of the HDA process to a change in the disturbance load of cold stream.....	72
Figure 6.3	Dynamic responses of Base Case of the HDA process to a change in the disturbance load of cold stream from the bottom of stabilizer column.....	73
Figure 6.4	Dynamic responses of Base Case of the HDA process to a change in the disturbance load of cold stream from the bottom of product column.....	74
Figure 6.5	Dynamic responses of Base Case of the HDA process to a change in the disturbance load of cold stream from the bottom of recycle column.....	75
Figure 6.6	Dynamic responses of Base Case of the HDA process to a change in the disturbance load of hot stream.....	76
Figure 6.7	Dynamic responses of Base Case of the HDA process to a change in the total toluene feed flowrate.....	77
Figure 6.8	Control structures 1 of the HDA process with three auxiliary Reboilers.....	84
Figure 6.9	Dynamic responses of CS1 of the HDA process to a change in the disturbance load of cold stream.....	85

Figure 6.10	Dynamic responses of CS1 of the HDA process to a change in the disturbance load of cold stream from the bottom of stabilizer column.....	86
Figure 6.11	Dynamic responses of CS1 of the HDA process to a change in the disturbance load of cold stream from the bottom of product column.....	87
Figure 6.12	Dynamic responses of CS1 of the HDA process to a change in the disturbance load of cold stream from the bottom of recycle column.....	88
Figure 6.13	Dynamic responses of CS1 of the HDA process to a change in the disturbance load of hot stream.....	89
Figure 6.14	Dynamic responses of CS1 of the HDA process to a change in the total toluene feed flowrate.....	90
Figure 6.15	Control structures 2 of the HDA process with three auxiliary reboiler.....	97
Figure 6.16	Dynamic responses of CS2 of the HDA process to a change in the disturbance load of the cold stream.....	98
Figure 6.17	Dynamic responses of CS2 of the HDA process to a change in the disturbance load of the cold stream from the bottom of the stabilizer column.....	99
Figure 6.18	Dynamic responses of CS2 of the HDA process to a change in the disturbance load of the cold stream from the bottom of the product column.....	100

Figure 6.19	Dynamic responses of CS2 of the HDA process to a change in the disturbance load of the cold stream from the bottom of the recycle column.....	101
Figure 6.20	Dynamic responses of CS2 of the HDA process to a change in the disturbance load of the hot stream.....	102
Figure 6.21	Dynamic responses of CS2 of the HDA process to a change in the total toluene feed flowrate.....	103
Figure 6.22	Control structures 3 of the HDA process with three auxiliary reboilers.....	109
Figure 6.23	Dynamic responses of CS3 of the HDA process to a change in the disturbance load of cold stream.....	110
Figure 6.24	Dynamic responses of CS3 of the HDA process to a change in the disturbance load of cold stream from the bottom of the stabilizer column.....	111
Figure 6.25	Dynamic responses of CS3 of the HDA process to a change in the disturbance load of cold stream from the bottom of the product column.....	112
Figure 6.26	Dynamic responses of CS3 of the HDA process to a change in the disturbance load of cold stream from the bottom of the recycle column.....	113
Figure 6.27	Dynamic responses of CS3 of the HDA process to a change in the disturbance load of hot stream.....	114
Figure 6.28	Dynamic responses of CS3 of the HDA process to a change in the total toluene feed flowrate.....	115

Figure 6.29	Base Case of the HDA process with minimum auxiliary reboilers.....	123
Figure 6.30	Dynamic responses of Base Case of the HDA process with minimum auxiliary reboiler to a change in the disturbance load of cold stream.....	124
Figure 6.31	Dynamic responses of Base Case of the HDA process with minimum auxiliary reboiler to a change in the disturbance load of cold stream from the bottom of stabilizer column.....	125
Figure 6.32	Dynamic responses of Base Case of the HDA process with minimum auxiliary reboiler to a change in the disturbance load of cold stream from the bottom of product column.....	126
Figure 6.33	Dynamic responses of Base Case of the HDA process with minimum auxiliary reboiler to a change in the disturbance load of cold stream from the bottom of recycle column.....	127
Figure 6.34	Dynamic responses of Base Case of the HDA process with minimum auxiliary reboiler to a change in the disturbance load of hot stream.....	128
Figure 6.35	Dynamic responses of Base Case of the HDA process with minimum auxiliary reboiler to a change in the total toluene feed flowrate.....	129

Figure 6.36	Control structures 1 of the HDA process with minimum auxiliary reboilers.....	136
Figure 6.37	Dynamic responses of CS1 of the HDA process with minimum auxiliary reboiler to a change in the disturbance load of cold stream.....	137
Figure 6.38	Dynamic responses of CS1 of the HDA process with minimum auxiliary reboiler to a change in the disturbanceload of cold stream from the bottom of stabilizer column.....	138
Figure 6.39	Dynamic responses of CS1 of the HDA process with minimum auxiliary reboiler to a change in the disturbance load of cold stream from the bottom of product column.....	139
Figure 6.40	Dynamic responses of CS1 of the HDA process with minimum auxiliary reboiler to a change in the disturbance load of cold stream from the bottom of recycle column.....	140
Figure 6.41	Dynamic responses of CS1 of the HDA process with minimum auxiliary reboiler to a change in the disturbance load of hot stream.....	141
Figure 6.42	Dynamic responses of CS1 of the HDA process with minimum auxiliary reboiler to a change in the total toluene feed flowrate.....	142

Figure 6.43	Control structures 2 of the HDA process with minimum auxiliary reboilers.....	149
Figure 6.44	Dynamic responses of CS2 of the HDA process with minimum auxiliary reboiler to a change in the disturbance load of cold stream.....	150
Figure 6.45	Dynamic responses of CS2 of the HDA process with minimum auxiliary reboiler to a change in the disturbance load of cold stream from the bottom of stabilizer column.....	151
Figure 6.46	Dynamic responses of CS2 of the HDA process with minimum auxiliary reboiler to a change in the disturbance load of cold stream from the bottom of product column.....	152
Figure 6.47	Dynamic responses of CS2 of the HDA process with minimum auxiliary reboiler to a change in the disturbanceload of cold stream from the bottom of recycle column.....	153
Figure 6.48	Dynamic responses of CS2 of the HDA process with minimum auxiliary reboiler to a change in the disturbance load of hot stream.....	154
Figure 6.49	Dynamic responses of CS2 of the HDA process with minimum auxiliary reboiler to a change in the total toluene feed flowrate.....	155

Figure 6.50	Control structures 3 of the HDA process with minimum auxiliary reboilers.....	162
Figure 6.51	Dynamic responses of CS3 of the HDA process with minimum auxiliary reboiler to a change in the disturbance load of cold stream.....	163
Figure 6.52	Dynamic responses of CS3 of the HDA process with minimum auxiliary reboiler to a change in the disturbance load of cold stream from the bottom of stabilizer column.....	164
Figure 6.53	Dynamic responses of CS3 of the HDA process with minimum auxiliary reboiler to a change in the disturbance load of cold stream from the bottom of product column.....	165
Figure 6.54	Dynamic responses of CS3 of the HDA process with minimum auxiliary reboiler to a change in the disturbance load of cold stream from the bottom of recycle column.....	166
Figure 6.55	Dynamic responses of CS3 of the HDA process with minimum auxiliary reboiler to a change in the disturbance load of hot stream.....	167
Figure 6.56	Dynamic responses of CS3 of the HDA process with minimum auxiliary reboiler to a change in the total toluene feed flowrate.....	168
Figure B.1	Input and Output from Relay-Feedback Test.....	184

NOMENCLATURES

AR_i	Auxiliary reboiler i
C_i	Cold stream i
$CS1$	Control structure 1
$CS2$	Control structure 2
$CS3$	Control structure 3
$FEHE_i$	Feed-effluent-heat-exchanger i
HEN	Heat exchanger network
H_i	Hot stream i
P_B	The partial pressure of benzene
P_D	The partial pressure of diphenyl
P_H	The partial pressure of hydrogen
P_T	The partial pressure of toluene
r_1	Reaction rate of main reaction to produce benzene
r_2	Reaction rate of side reaction to produce diphenyl
R_i	Reboiler i

CHAPTER I

INTRODUCTION

Modern industrial processes contain a complex flow sheet with several recycle streams, heat integration, and many different unit operations. The main goal of the plantwide process control is how to develop the control loops that need to operate a process and achieve its design objectives. Normally, the problem is quite large and complex. It involves a large number of theoretical considerations such as a quality of controlled response, stability of the system, the safety of the operating plant, the reliability of control system, the ease of operation etc. Besides, it is very much open-ended problem. There are a number of possible choices and alternative strategies. So there is no unique "correct" solution because the "best" control structure for a plant depends on the design and control criteria established.

In the previous time, plant also contained many surge tanks to prevent disturbances, propagation, and to minimize interactions but the energy management and economic are neglected. However, since the oil crisis in the 1980s, there is growing pressure to reduce capital investment, working capital, and to improve safety and environmental concerns. So design engineers begin to eliminate many surge tanks, increase recycle streams, and introduce heat integration. These are all economically attractive in the steady state flow sheet, but they present significant challenges to smooth dynamic plant operation.

1.1 Background

Terrill and Douglas (1987) proposed six different energy-saving alternatives of HDA process. The simplest of these designs (Alternative 1) recovers an additional 29 percent of the base case heat consumption by making the reactor preheater larger and the furnace smaller. The most complicated of the designs (Alternative 6) recovers 43 percent of the base case heat consumption. To control such a complex heat integration scheme (Alternative 6), design modifications to process

is needed to ensure controllability and operability. Luyben (1999) solves some of the control difficulties associated with Alternative 6 by adding auxiliary utility coolers and reboilers to the process. The modified HDA process (Alternative 6) needs three new reboilers and three utility coolers to improved controllability. The coolers are located in bypass streams around the process-to-process reboilers so that disturbances in the heat balance can be dissipated quickly to utilities without propagating through the entire plant. For this structure, disturbances are rejected to the auxiliary coolers when the column temperature controllers divert excess heat around the main reboilers. The auxiliary reboilers are used to provide a quick source of energy for the columns. So, heat deficiencies in the process are not propagated to the next downstream unit operation. However, some of extra equipments and control valves added made this design less attractive economically, besides some equipment design issues are needed to be solved (Luyben, 1998).

In this work, the worst case condition is made for to design the HDA process with minimum auxiliary reboilers and guarantee the workable process. It is selected to be the design condition that minimum heat supply and maximum heat demand. The design strategy to minimize the equipment cost, i.e. auxiliary reboiler uses the heat pathway analysis. Additional, we present three new control structures of plant with minimum auxiliary reboiler in order to achieve the minimum equipment cost. The plant chosen for this research is the plant to produce benzene from the hydrodealkylation (HDA) of toluene process (Alternative 6), since it consists of recycle streams and energy integration.

1.2 Objectives of the Research

The objectives of this work are listed below:

1. Design the worst case condition for to guarantee the workable Alternative 6 of HDA process.
2. Design the new control structures with minimum auxiliary reboilers for heat-integrated HDA process.

1.3 Scopes of the Research

1. The HDA process with energy integration schemes (Alternative 6 which given by Terrill and Douglas, 1987) is chosen for a case study.
2. The description of HDA process is given by Douglas (1988) and Luyben et al., (1999).
3. Simulation of the hydrodealkylation (HDA) of toluene process (Alternative 6) is performed by using a commercial process simulator - HYSYS.

1.4 Contributions of the Research

The contributions of this work are as follows:

1. The new plantwide control structure with minimum auxiliary reboilers for energy-integrated hydrodealkylation (HDA) of toluene process is designed.
2. The capital cost of process for energy-integrated hydrodealkylation (HDA) of toluene process is decreased.

1.5 Research Procedures

The procedures of this research are as follows:

1. Study plantwide process control theory.
2. Study HDA process and concerned information.
3. Steady state simulation of Alternative 6 of HDA process. In this step, the worst case is made for to guarantee the workable HDA process.
 - (a) Determine the operating condition for HEN based on the input disturbance loads (worst case condition is defined).
 - (b) Determine design conditions for HEN based on the input disturbance loads (worst case condition is designed).

- (c) Check the workable HDA process in HEN at worst case conditions based on the input disturbance loads.
4. Design new control structure of the HDA process with highly complex heat integration and minimum auxiliary reboilers.
5. Simulate dynamic of Alternative 6 of HDA process with minimum auxiliary reboilers.
6. Evaluate and analyze of the dynamic performance of the designed control structures.
7. Summarize of simulation results.

1.6 Research Framework

This thesis has been divided into seven chapters.

In **Chapter I**, the background, objectives, scopes, contributions and research planning of this research is introduced in this chapter.

In **Chapter II**, a review of the previous work on the conceptual design of chemical process, heat exchanger networks (HENs) design and plantwide process control design are given.

In **Chapter III**, background information of plantwide control, plantwide control design procedure, plantwide energy management and heat exchanger network are presented.

Chapter IV describes the description of the hydrodealkylation (HDA) of toluene process that is the case study for this research.

Chapter V presents a design of workable complex heat-integrated HDA process and results of a steady state simulation.

Chapter VI shows design of control structures and dynamic simulation of Alternative 6 of HDA plant .

The overall conclusions and recommendations of this thesis are discussed in **Chapter VII**.

This is follow by:

Appendix A: Cost Estimation

Appendix B: Tuning of Control structures

Appendix C: Parameter Tuning

Appendix D: Results of IAE value



สถาบันวิทยบริการ
จุฬาลงกรณ์มหาวิทยาลัย

CHAPTER II

LITERATURE REVIEW

Our purpose of this chapter is to present a review of the previous work on the conceptual design of chemical process, heat exchanger networks (HENs) and plantwide control design.

2.1 Conceptual Design

A synthesis/analysis procedure for developing first flowsheets and base case designs has been established by Douglas (1985). The procedure is described in terms of a hierarchy of decision levels, as follows:

1. Batch versus continuous
2. Input-output structure of the flowsheet
3. Recycle structure of the flowsheet
4. Separation system specification, including vapor and liquid recovery system
5. Heat exchanger network(HEN)

Douglas (1985) considered a continuous process for producing benzene by hydrodealkylation of toluene (HDA process) to illustrate the procedure. The complete process is always considered at each decision level, but additional fine structure is added to the flowsheet as he proceeds to the later decision level. Each decision level terminates in an economic analysis. Experience indicates that less than one percent of the ideals for new designs are ever commercialized, and therefore it is highly desirable to discard poor projects quickly. Similarly, the later level decisions are guided by the economic analysis of the early level decisions.

In a series of papers, Fisher et al. (1988 a, b, c) presented a study of the interface between design and control including process controllability, process

operability and selecting a set of controlled variables. At the preliminary stages of a process design, most plants are uncontrollable. That is normally there are not enough manipulative variables in the flowsheet to be able to satisfy all of the process constraints and to optimize all of the operating variables as disturbances enter the plant. In order to develop a systematic procedure for controllability analysis, Fisher et al. (1988a) used the design decision hierarchy described by Douglas (1985) as the decomposition procedure and considered HDA process as a case study. Where at some levels, that are level 1, 2 and 3, the process is uncontrollable, but controllable at level 4 and level 5. If the available manipulated variables are compared with the constraints and operating variables introduced at each level, the preliminary controllability criterion can often be satisfied.

Beside controllability analysis, Fisher et al. (1988b) also focused on operability analysis. The goal of operability analysis is to ensure that there is an adequate amount of equipment over design so that they could satisfy the process constraints and minimize a combination of the operating costs and over design costs over the entire range of anticipated process disturbances. They also followed the same hierarchical procedure to develop operability analysis. For HDA process, the operability decisions were encountered at each level. Fisher et al. (1988c) proposed steady state control structure for HDA process using an optimum steady state control analysis. They found the values of manipulated variables (that minimize the total operating costs for various values of the disturbances) and used it to define the controlled variables.

D. L. Terrill and J. M. Douglas (1988) have studied HDA process from a steady state point of view and determined that the process can be held very close to its optimum for a variety of expected load disturbances by using the following strategy: (1) Fix the flow of recycle gas through the compressor at its maximum value, (2) Hold a constant heat input flowrate in the stabilizer, (3) Eliminate the reflux entirely in the recycle column, (4) Maintain a constant hydrogen-to-aromatic ratio in the reactor inlet by adjusting hydrogen fresh feed, (5) Hold the recycle toluene flowrate constant by adjusting fuel to the furnace, (6) Hold the temperature of the cooling water leaving the partial condenser constant.

Downs and Vogel (1993) described a model of an industrial chemical process for the purpose of developing, studying and evaluating process control technology. It consisted of a reactor/separator/recycle arrangement involving two simultaneous gas-liquid exothermic reactions. This process was well suited for a wide variety of studies including both plantwide control and multivariable control problems.

Tyreus and W. L. Luyben (1993) considered second order kinetics with two fresh feed makeup streams. Two cases are considered: (1) instantaneous and complete one pass conversion of one of the two components in the reactor so there is an excess of only one component that must be recycled and (2) incomplete conversion per pass so there are two recycle streams. It is shown that the generic liquid-recycle rule proposed by Luyben applies in both of these cases: "snowballing" is prevented by fixed the flowrate somewhere in the recycle system. An additional generic rule is proposed fresh feed makeup of any component cannot be fixed unless the component undergoes complete single-pass conversion. In the complete on-pass conversion case, throughput can be set by to fix the flowrate of the limiting reactant. The makeup of the other reactant should be set by level control in the reflux drum of the distillation column.

Yi and Luyben (1995) presented a method that was aimed at helping to solve this problem by providing a preliminary screening of candidate plantwide control structures in order to eliminate some poor structures. Only steady state information was required. Equation-based algebraic equation solvers were used to find the steady state changes that occur in all manipulated variables for a candidate control structure when load changes occur. Each control structure fixed certain variables: flows, compositions, temperatures, etc. The number of fixed variables was equal to the number of degrees of freedom of the closed-loop system. If the candidate control structure required large changes in manipulated variables, the control structure was a poor one because valve saturation and/or equipment overloading will occur. The effectiveness of the remaining structures was demonstrated by dynamic simulation. Some control structures were found to have multiple steady states and produce closed-loop instability.

2.2 Heat Exchanger Networks (HENs)

Linhoff, B. and Hindmarsh, E. (1983) presented a novel method for the design of HEN. The method is the first to combine sufficient simplicity to be used by hand with near certainty to identify "best" designs, even for large problems. Best design features the highest degree of energy recovery possible with a given number of capital items. Moreover, they feature network patterns required for good controllability, plant layout, intrinsic safety, etc. Typically, 20-30 percent energy savings, coupled with capital saving, can be realized in state of the art flowsheets by improved HEN design. The task involves the placement of process and utility heat exchangers to heat and cool process streams from specified supply to specified target temperatures.

Generally, minimum cost networks feature the correct degree of energy recovery and the correct number of units. This is achieved in two stages. First, the method aims for a minimum energy solution, corresponding to a specified ΔT_{min} with no more units than is compatible with minimum energy. This task is achieved through understanding of the pinch phenomenon, hence the method is called the pinch design method. Second, the method involves a controlled reduction in number of units. This may require "backing-off" from minimum utility usage.

1. The HEN problem is divided at the pinch into separate problems.
2. The design for this separate problem is started at the pinch and developed moving away from the pinch. At the pinch essential matches, match options and stream splitting requirements are identified by applying the feasibility criteria.
3. When options exist at the pinch, the engineer is free to base his selection to suit the process requirements.
4. The heat loads of exchangers at the pinch are determined using the stream tick-off heuristic. In case of difficulty, a different exchanger topology at the pinch can be chosen or the load on the offending match can be reduced.

5. Away from the pinch there is generally a free choice of matches. The procedure does not insist on particular matches but allows the designers to discriminate between matches based on his judgment and process knowledge.

Linhoff, B., Dunford, H., and Smith, R., (1983) studied heat integration of distillation columns into overall process. This study reveals that good integration between distillation and the overall process can result in column operating at effectively zero utility cost. Generally, the good integration is when the integration as column not crossing heat recovery pinches of the process and either the reboiler or the condenser being integrated with the process. If these criteria can be met, energy cost for distillation can effectively be zero.

Saboo and Morari (1983) classified flexible HENs into two classes according to the kind and magnitude of disturbances that effect the pinch location. For the temperature variation, they show that if the MER can be expressed explicitly as a function of stream supply and target conditions the problem belongs to Class I, i.e. the case that small variations in inlet temperatures do not affect the pinch temperature location. If an explicit function for the minimum utility requirement valid over the whole disturbance range does not exist, the problem is of Class II, i.e. the case that large changes in inlet temperature of flowrate variations cause the discrete changes in pinch temperature locations.

Calandranis and Stephanopoulos (1988) proposed a new approach to address the following problems: design the configuration of control loops in a network of heat exchangers and sequence the control action of the loops, to accommodate set point changes and reject load disturbances. The approach proposed exploits the structure characteristics of a HEN by identifying routes through the HEN structure that can allocate load (disturbances, or set point changes) to available sinks (external coolers or heaters). They also discussed several design issues such as the placement of bypass lines and the restrictions imposed by the existence of a process pinch. An online, real-time planning of control actions is the essence of implementation strategies generated by an expert controller, which selects path

through the HEN is to be used for each entering disturbance or set point change, and what loops should be activated (and in what sequence) to carry the associated load (disturbance or set point change) to a utility unit.

In a series papers, studies of the sensitivity of the total processing cost to heat exchanger network alternatives and steady state operability evaluation were undertaken by Terrill and Douglas (1987 a, b, c). They considered the temperature-enthalpy (T-H) diagram and developed six HEN alternatives for a base case design for HDA process which energy savings ranging between 29 and 43 percent. The simplest of these designs is alternative 1, recovers an additional 29 percent of the base case heat consumption by making the reactor preheater larger and the furnace smaller. The most complicated of the design is alternative 6, recovers 43 percent of the base case net energy consumption.

Several terms have been used in the literature to describe the additional attributes of HENs that have a capability to tolerate change in input or operational parameters while achieving the targets. Operability has been used to describe the ability of the system to perform satisfactorily under normal and abnormal conditions different design condition. Normal refers to the steady state operation while abnormal refers to the transient operation during failure, start up or shut down periods. Flexibility has been used to describe the ability of process systems to readily adjust to meet the requirement of changes, i.e. different feed stocks, product specifications or process conditions. Resiliency refers to the ability of HEN to tolerate and recover from undesirable parameter variations, and the term static resiliency or simply resiliency has been used in the same sense as flexibility. Dynamic resiliency refers to ability to handle the unsteady state operation.

Colberg (1989) suggested that flexibility should deal with planned, desirable changed that often have a discrete set of values. Whereas resilience deals with unplanned, undesirable changes which are naturally continuous values. Thus a flexibility problem is a 'multiple period' type pf problem. A resilience problem should be a problem with a continuous range of operating conditions in the neighborhood of nominal operating points.

Wongsri, M., (1990) studied a resilient HEN design. He presented a simple but effective systematic synthesis procedure for the design of resilient HEN. His heuristic design procedure is used to design or synthesize HENs with pre-specified resiliency. It used physical and heuristic knowledge in finding resilient HEN structures. The design must not only feature minimum cost, but must also be able cope with fluctuation or changes in operating conditions. The ability of a HEN to tolerate unwanted changes is called resiliency. It should be noted that the ability of a HEN to tolerate wanted changes is called flexibility. A resilient HEN synthesis procedure was developed based on the match pattern design and a physical understanding of the disturbances propagation concept. The disturbance load propagation technique was developed from the shift approach and was used in a systematic synthesis method. The design condition was selected to be the minimum heat load condition for easy accounting and interpretation. This is a condition where all process streams are at their minimum heat loads, e.g. the input temperatures of hot streams are at the lowest and those of cold streams are at the highest.

Generating designs at a base case and some extreme conditions and combining those designs to a base design requires that the designs should be similar. However, the networks designed at extreme conditions can be very different from each other. This poses difficulties in the combination. These methods involve repetitive effort in finding a resilient structure because the resiliency objective has not been included in their models. Also, the problem of selecting extreme conditions is far from trivial. Grossmann and Morari (1984) show that the extreme conditions that seem logical can lead to a poor design. Most of us would select the maximum and minimum operating conditions as design conditions. However, in their example the extreme condition is located at the intermediate value. Extra units in a combined design are then eliminated by either inspection or using optimization methods to obtain a minimum unit solution. A minimum unit solution is tested for resiliency using mathematical programming or inspection techniques.

Marselle et al. (1982) addressed the problem of synthesizing heat recovery networks, where the inlet temperatures vary within given ranges and presented

the design procedure for a flexible HEN by finding the optimal network structures for four selected extreme operating conditions separately. The specified worst cases of operating conditions are the maximum heating, the maximum cooling, the maximum total exchange and the minimum total exchange. The network configurations of each worst condition are generated and combined by a designer to obtain the final design. The strategy is to derive similar design in order to have as many common units as possible in order to minimize number of units.

Linnhoff and Kotjabasakis (1984) developed a design procedure for operable HENs by inspection and using the concept of downstream paths, i.e. the paths that connect the disturbed variables downstream to the controlled variables. They generated HEN design alternatives by the pinch method for the nominal operating condition. Then, the alternative designs are inspected for the effects of disturbances on the controlled variables and they are removed by breaking the troublesome downstream paths. Path breaking can be done by relocating and/or removing exchangers. If this procedure is not feasible, control action is inserted into the structure.

Saboo and Morari (1984) proposed the corner point theorem which states that for temperature variation only, if a network allows MER without violating ΔT_{min} at M corner points, then the network is structurally resilient or flexible. This is the case where the constraint is convex, so examining the vertices of the polyhedron is sufficient. This procedure again can only apply to restricted classes of HEN problem. Their design procedure is similar to Marselle et al. (1982), but using two extreme cases to develop the network structure. The strategy for both procedures is finding similar optional network structures for the extreme cases and the base case design in order that they may be easily merged and not have too many units. Two extreme cases are:

1. When all streams enter at their maximum inlet temperatures and the heat capacity flowrates of hot streams are maximal and those of cold streams minimal. This is the case of maximum cooling.
2. When all streams enter at their minimum inlet temperatures and the heat

capacity flowrates of hot streams are minimal and those of cold streams maximal. This is an opposite case the above one and in this case maximum heating is required.

The 'base' design is then generated by using an optimization technique and the final design is obtained by combining these designs. A test for resiliency (calculating, RI) is required. If the design is not feasible a modification is done by attempting to reduce ΔT_{min} and if not successful, a new heat exchanger will added or some heat exchangers are located. If the modified network is still not resilient, synthesize network structures at all corner points where the current design is not feasible. The new structures should be as similar to the current design as possible. The new design is obtained by superimposing the current structure and the new structures. The unneeded heat exchangers are inspected and removed.

Floudas and Grossmann (1987) presented a synthesis procedure for resilient HENs. Their multiperiod operation transshipment model is used to find a match structure for selected design points. The design obtained for feasibility at the match level. If it is not feasible, the critical point is added as an additional operating point and the problem is reformulated and solved. If the match network is feasible then the multiperiod superstructure is derived and formulated as an NLP problem to find a minimum unit solution.

Ploypaisangsang A., (2003) presented to redesign six alternatives for HDA process to be the resiliency networks for maintain the target temperature and also achieve maximum energy recovery (MER). The best resilient network is selected by to trade-off between cost and resiliency. The auxiliary unit should be added in the network for cope safely with the variations and easy to design control structure to the network.

2.3 Design and Control of Heat-Integrated Process

In the last few decades, Douglas, Orcutt, and Berthiaume (1962) studied design and control of feed-effluent heat exchanger - reactor systems. They obtained a simultaneous solution of the steady state heat and material balances for a first order reaction occurring in the system and used it to calculate the values of exchanger and reactor lengths that minimized the equipment cost of the system. A dynamic study indicated that the desired steady state conditions were met stable. However, proportional controller could be used to stabilize the process.

Silverstein and Shinnar (1982) discussed the linear and nonlinear stability analysis of a fixed bed catalytic reactor with heat exchanger between the feed and product streams, with special emphasis on case which are open loop unstable. They used classical frequency response techniques, contains the implicit assumption that the designer should evaluate the effect of the overall design on stability. Tyreus, B.D. and Luyben, W. L., (1993) presented a mathematical analysis of the unusual dynamic in coupled reactor/preheater process. The outlet temperature of the reactor exhibits inverse response for a change in the inlet reactor temperature and a large dead time.

Handogo, R. and Luyben, W. L., (1987) studied the dynamics and control of a heat-integrated reactor/column system. An exothermic reactor was the heat source, and a distillation column reboiler was the heat sink. Two types of heat-integrated system were examined: indirect and direct heat integration. Both indirect and direct heat-integration systems are found in industry. In the indirect heat-integration system, steam generation was used to cool the reactor, and the steam was used as the heating medium for the reboiler. The direct heat-integration system used the reactor fluid to directly heat the column reboiler. The indirect heat-integration system was found to have several advantages over the direct heat-integration system in terms of its dynamic performance. Both systems were operable for both large and small temperature differences between the reactor and column base. Somewhat unexpectedly, the heat-integration system with a small temperature difference was found to be more controllable than a system with a larger temperature difference. However, the cost of the heat exchanger increased rapidly as the temperature difference decreased. An important thing

in this study is how to solve some of control difficulties in the process associated with heat integration schemes. They suggested adding auxiliary utility coolers and reboilers to the process.

M.L. Luyben and W.L. Luyben (1995) examined the plantwide design and control of a complex process. The plant contains two reactions steps, three distillation columns, two recycle streams, and six chemical components. Two methods, a heuristic design procedure and a nonlinear optimization, have been used to determine an approximate economically optimal steady state design. The designs differ substantially in terms of the purities and flowrates of the recycle streams. The total annual cost of the nonlinear optimization design is about 20 percent less than the cost of the heuristic design. An analysis has also been done to examine the sensitivity to design parameters and specifications. Two effect control strategies have been developed using guidelines from previous plantwide control studies; both require reactor composition control as well as flow control of a stream somewhere in each recycle loop. Several alternative control strategies that might initially have seemed obvious do not work.

Jones, W.E., and Wilson, J.A., (1997) considered the range ability of flows in the bypass line of heat exchanger through interesting heat exchanger problems. Difficulty is immediately encountered when considering heat exchanger between two process streams; changing the flowrate of one will certainly affect the exit temperature of the other. Unfortunately, interfering with a process stream flowrate immediately upsets the plant mass balance, which is undesirable. The difficulty is overcome by using a bypass that does not affect the total flowrate but changes the proportion actually passing through the heat exchanger and hence the heat transfer. Good engineering practice would maintain a minimum flowrate of 5-10 percent through the bypass. This bypass is expected to be able to handle disturbances.

Luyben, M.L., Tyreus, B.D. and Luyben, W.L., (1997) presented a general heuristic design procedure. Their procedure generated an effective plantwide control structure for an entire complex process flowsheet and not simply individual

units. The nine steps of the proposed procedure center around the fundamental principles of plantwide control: energy management, production rate, product quality, operational, environmental and safety constraints, liquid-level and gas-pressure inventories, makeup of reactants, component balances and economic or process optimization. Application of the procedure was illustrated with three industrial examples: the vinyl acetate monomer process, Eastman process and HDA process. The procedure produced a workable plantwide control strategy for a given process design. The control system was tested on a dynamic model built with TMODES, Dupont's in-house simulator.

From the W.L. Luyben (2000) studied the process had the exothermic, irreversible, gas - phase reaction $A + B \rightarrow C$ occurring in an adiabatic tubular reactor. A gas recycle returns unconverted reactants from the separation section. Four alternative plantwide control structures for achieving reactor exit temperature control were explored. The reactor exit temperature controller changed different manipulated variables in three of the four control schemes: (1) CS1, the setpoint of the reactor inlet temperature controller was changed; (2) CS2, the recycle flowrate was changed; and (3) CS3, the flowrate of one of the reactant fresh feeds was changed. The fourth control scheme, CS4, uses an "on - demand" structure. Looking that the dynamics of the reactor in isolation would lead one to select CS2 because CS1 had a very large deadtime and CS3 had a very small gain. Dynamic simulations demonstrated that in the plantwide environment, with the reactor and separation operating together, the CS3 structure gave effective control and offered an attractive alternative in those cases where manipulation of recycle flowrate was undesirable because of compressor limitations. The on - demand CS4 structure was the best for handling feed composition disturbances. Kunlawaniteewat, J.,(2001) proposed the rules and procedure for design control structure of heat exchanger network using heuristic approach for to achieve outlet temperature targets and maintain maximum energy recovery (MER). The rules are categorized as following: generals, match pattern, loop placement, bypass placement, and split fraction rules.

Wongsri and Kietawarin (2002) presented a comparison among four con-

trol structures designed for withstanding disturbances that cause production rate change of HDA process. The changes had been introduced to the amount of toluene and feed temperature before entering the reactor. Compared with the reference control structure using a level control to control toluene quantity in the system, the first control scheme measured toluene flowrate in the process and adjusted the fresh toluene feed rate. This structure resulted in faster dynamic response than the reference structure. The second control scheme was modified from the first scheme by adding a cooling unit to control the outlet temperature from the reactor, instead of using internal process flow. The result was to reduce material and separation ratio fluctuations within the process. The product quality was also quite steadily. In the third control scheme, a ratio control was introduced to the second control scheme for controlling the ratio of hydrogen and toluene within the process. This scheme showed that it could withstand large disturbances. Dynamic study showed that the control structure had significant effect on process behavior. A good system control should quickly response to disturbances and adjusts itself to steady state while minimizing the deviation of the product quality.

Chen, T.H., and Yu, C.C. (2003) proposed systematic approach to complex FEHE schemes. Because a loss of controllability come the positive feedback loop, several design parameters were studied, and the design heuristic were proposed to give more controllable heat integration schemes. They used two examples, a simple two-FEHE example and an HDA process example to illustrate the assessment of controllability based on process flowsheet. The results showed that, contrary to expectations, some complex heat-integrated reactor design alternatives (e.g., alternative 6 of HDA example) were indeed more controllable than some of the simpler heat-integration schemes (e.g., alternative 1). The increased number of FEHEs allows for a greater number of candidate manipulated inputs and thus provides opportunities for multivariable control.

Wongsri and Thaicharoen (2004) presented the new control structures for HDA process with energy integration schemes alternative 3. Five control structures have been designed, tested and compared the performance with Luyben's

structure (CS1). The result showed that the HDA process with heat integration can reduce energy cost. Furthermore, this process can be operated well by using plantwide methodology to design the control structure. The dynamics responses of the designed control structures and the reference structure are similar. The CS2 has been limited in bypass. So, it is able to handle in small disturbances. The CS3 has been designed to improve CS2 in order to handle more disturbances by using auxiliary heater instead of bypass valve to control temperature of stabilizer column. The recycle column temperature control response of the CS4 is faster than that of the previous control structures, because reboiler duty of column can control the column temperature more effective than bottom flow. The CS5, on-demand structure has an advantage when downstream customer desires immediate responses in the availability of the product stream from this process. The energy used in CS6 control structure is less than CS1 and CS4.

Wongsri and Hermawan Y.D., (2004) studied the control strategies for energy integrated HDA plant (i.e. alternative 1, 4 and 6) based on the heat pathway heuristics, i.e. selecting an appropriate heat pathway to carry associated load to a utility unit, so that the dynamic maximum energy recovery (DMER) can be achieved with some trade-off. In addition, a selective controller with low selector switch (LSS) is employed to select an appropriate heat pathway through the network. The new control structure with the LSS has been applied in the HDA plant.

สถาบันวิทยบริการ
จุฬาลงกรณ์มหาวิทยาลัย

CHAPTER III

PLANTWIDE CONTROL FUNDAMENTALS

A typical chemical plant flowsheet has a mixture of multiple units connected both in series and parallel that consist of reaction sections, separation sections and heat exchanger network. So Plantwide Process Control involves the system and strategies required to control entire plant consisting of many interconnected unit operations.

3.1 Incentives for Chemical Process Control

A chemical plant is an arrangement of processing units (reactors, heat exchangers, pumps, distillation columns, absorbers, evaporators, tanks, etc.), integrated with one another in a systematic and rational manner. The plant's overall objective is to convert certain raw materials into desired products using available source of energy, in the most economical way.

There are three general classes of needs that a control system is called on to satisfy: suppressing the influence of external disturbances, ensuring the stability of a chemical process, and optimizing the performance of a chemical process.

3.1.1 Suppressing the Influence of External Disturbances

Suppressing the influence of external disturbances on a process is the most common objective of a controller in a chemical plant. Such disturbances, which denote the effect that the surroundings have on the reactor, separator, heat exchanger, and compressor, are usually out of the reach of human operator. Consequently, we need to introduce a control mechanism that will make the proper change on the process to cancel the negative impact that such disturbances may have on the desired operation of a chemical plant.

3.1.2 Ensuring the Stability of a Chemical Process

The process is stable or self-regulating, if the process variables such as temperature, pressure, concentration, or flowrate stay at a certain point or a desired steady state value as time progresses. Otherwise, the process is unstable and requires external control for the stabilization of their behavior.

3.1.3 Optimizing the Performance of a Chemical Process

Safety and the satisfaction of product specifications are the two principal operational objectives for a chemical plant. Once these are achieved, the next goal is how to make the operation of the plant more profitable. Given the fact that the conditions that affect the operation of the plant do not remain the same, it is clear that we would like to be able to change the operation of the plant (flowrate, pressure, concentration, temperature) in such a way that an economic objective is always maximized.

3.2 Integrated Process

Three basic features of integrated chemical process lie at the root of our need to consider the entire plant's control system: the effect of material recycle, the effect of energy integration, and the need to account for chemical component inventories.

3.2.1 Material Recycles

Material is recycled for six basic and important reasons.

1. *Increase conversion.* For chemical processes involving reversible reactions, conversion of reactants to products is limited by thermodynamic equilibrium constraints. Therefore the reactor effluent by necessity contains both reactants and products. Separation and recycle of reactants are essential if the process is to be economically viable.
2. *Improve economics.* In most systems it is simply cheaper to build a reactor with incomplete conversion and recycle reactants than it is to reach the

necessary conversion level in one reactor or several in series. A reactor followed by a stripping column with recycle is cheaper than one large reactor or three reactors in series.

3. *Improve yields.* In reaction system such as $A \rightarrow B \rightarrow C$, where B is the desired product, the per-pass conversion of A must be kept low to avoid producing too much of the undesirable product C. Therefore the concentration of B is kept fairly low in the reactor and a large recycle of A is required.
4. *Provide thermal sink.* In adiabatic reactors and in reactors where cooling is difficult and exothermic heat effects are large, it is often necessary to feed excess material to the reactor (an excess of one reactant or a product) so that the reactor temperature increase will not be too large. High temperature can potentially create several unpleasant events: it can lead to thermal runaways, it can deactivate catalysts, it can cause undesirable side reactions, it can cause mechanical failure of equipment, etc. So the heat of reaction is absorbed by the sensible heat required to rise the temperature of the excess material in the stream flowing through the reactor.
5. *Prevent side reactions.* A large excess of one of the reactants is often used so that the concentration of the other reactant is kept low. If this limiting reactant is not kept in low concentration, it could react to produce undesirable products. Therefore the reactant that is in excess must be separated from the product components in the reactor effluent stream and recycled back to the reactor.
6. *Control properties.* In many polymerization reactors, conversion of monomer is limited to achieve the desired polymer properties. These include average molecular weight, molecular weight distribution, degree of branching, particle size, etc. Another reason for limiting conversion to polymer is to control the increase in viscosity that is typical of polymer solutions. This facilitates reactor agitation and heat removal and allows the material to be further processed.

3.2.2 Energy Integration

The fundamental reason for the use of energy integration is to improve the thermodynamics efficiency of the process. This translates into a reduction in utility cost.

3.2.3 Chemical Component Inventories

In chemical processes can characterize a plant's chemical species into three types: reactants, products, and inert. The real problem usually arises when we consider reactants (because of recycle) and account for their inventories within the entire process. Every molecule of reactants fed into the plant must either be consumed or leave as impurity or purge. Because of their value so we prevent reactants from leaving. This means we must ensure that every mole of reactant fed to the process is consumed by the reactions.

This is an important, from the viewpoint of individual unit, chemical component balancing is not a problem because exit streams from the unit automatically adjust their flows and composition. However, when we connect units together with recycle streams, the entire system behaves almost like a pure integrator in terms of reactants. If additional reactant is fed into the system without changing reactor conditions to consume the reactants, this component will build up gradually within the plant because it has no place to leave the system.

3.3 Effects of Recycle

Most real processes contain recycle streams. In this case the plantwide control problem becomes much more complex. Two basic effect of recycle is: Recycle has an impact on the dynamics of the process. The overall time constant can be much different than the sum of the time constants of the time constants of the individual units. Recycle leads to the "snowball" effect. A small change in throughput or feed composition can lead to a large change in steady-state recycle stream flowrates.

3.3.1 Snowball Effect

Snowball effect is high sensitivity of the recycle flowrates to small disturbances. When feed conditions are not very different, recycle flowrates increase drastically, usually over a considerable period of time. Often the equipment cannot handle such a large load. It is a steady-state phenomenon but it does have dynamic implications for disturbance propagation and for inventory control.

The large swings in recycle flowrates are undesirable in plant because they can overload the capacity of separation section or move the separation section into a flow region below its minimum turndown. Therefore it is important to select a plantwide control structure that avoids this effect.

3.4 Basic Concepts of Plantwide Control

3.4.1 Buckley Basic

Page Buckley (1964) was the first to suggest the idea of separating the plantwide control problem into two parts:

1. Material balance control.
2. Production quality control.

He suggested looking first at the flow of material through the system. A logical arrangement of level and pressure control loop is established, using the flowrates of liquid and gas process streams. He then proposed establishing the product-quality control loops by choosing appropriate manipulated variables. The time constants of the closed-loop product-quality loops are estimated as small as possible. The most level controllers should be proportional-only (P) to achieve flow smoothing.

3.4.2 Douglas Doctrines

Jim Douglas (1988) has devised a hierarchical approach to the conceptual design of process flowsheets. Douglas points out that in the typical chemical plant

the costs of raw materials and the value of the products are usually much greater than the costs of capital and energy. This leads to two Douglas doctrines.

1. Minimize losses of reactants and products.
2. Maximize flowrates through gas recycle systems.

The first implies that we need tight control of stream composition exiting the process to avoid losses of reactants and products. The second rests on the principle that yield is worth more than energy.

The control structure implication is that we do not attempt to regulate the gas recycle flow and we do not worry about what we control with its manipulation. We simply maximize its flow. This removes one control degree of freedom and simplifies the control problem.

3.4.3 Downs Drill

Jim Downs (1992) pointed out the importance of looking at the chemical component balances around the entire plant and checking to see that the control structure handles these component balances effectively. We must ensure that all components (reactants, product, and inert) have a way to leave or be consumed within the process. Most of the problems occur in the consideration of reactants, particularly when several chemical species are involved. Because we usually want to minimize raw material costs and maintain high-purity products, most of the reactants fed into the process must be chewed up in the reactions. And the stoichiometry must be satisfied down to the last molecule. Chemical plants often act as pure integrators in terms of reactants will result in the process gradually filling up with the reactant component that is in excess. There must be a way to adjust the fresh feed flowrates so that exactly the right amounts of the two reactants are fed in.

3.4.4 Luyben Laws

Three laws have been developed as a result of a number of case studies of many types of system:

1. All recycle loops should be flow controlled.
2. A fresh reactant feed stream cannot be flow-controlled unless there is essentially complete one-pass conversion of one of the reactants.
3. If the final product from a process comes out the top of a distillation column, the column feed should be liquid. If the final product comes out the bottom of a column, the feed to the column should be vapor (Cantrell et al., 1995). Even if steady-state economics favor a liquid feed stream, the profitability of an operating plant with a product leaving the bottom of a column may be much better if the feed to column is vaporized.

3.4.5 Richardson Rule

Bob Richardson suggested the heuristic that the largest stream should be selected to control the liquid level in a vessel. (The bigger the handle you have to affect a process, the better you can control it).

3.4.6 Shinskey Schemes

Greg Shinskey (1988) has produced a number of "advanced control" structures that permit improvements in dynamic performance.

3.4.7 Tyreus Tuning

Use of P-only controllers for liquid levels, turning of P controller is usually trivial: set the controller gain equal to 1.67. This will have the valve wide open when the level is at 80 percent and the valve shut when the level is at 20 percent.

For other control loops, suggest the use of PI controllers. The relay-feedback test is a simple and fast way to obtain the ultimate gain (K_u) and ulti-

mate period (P_u). Then either the Ziegler-Nichols setting or the Tyreus-Luyben (1992) settings can be used:

$$\begin{aligned} K_{ZN} &= K_u/2.2 & \tau_{ZN} &= P_u/1.2 \\ K_{TL} &= K_u/3.2 & \tau_{TL} &= 2.2P_u \end{aligned}$$

The use of PID controllers, the controlled variable should have a very large signal-to-noise ratio and tight dynamic control is really essential from a feedback control stability perspective.

3.5 Step of Plantwide Process Control Design Procedure

Step1: Establish control objectives

Assess the steady-state design and dynamic control objects for the process. This is probably the most important aspect of the problem because different control objectives lead to different control structures. The "best" control structure for a plant depends upon the design and control criteria established.

These objectives include reactor and separation yields, product quality specification, product grades and demand determination, environmental restrictions, and the range of safe operating conditions.

Step 2: Determine control degrees of freedom

This is the number of degrees of freedom for control, i.e., the number of variables that can be controlled to set point. The placement of these control valves can sometimes be made to improve dynamic performance, but often there is no choice in their location.

Most of these valves will be used to achieve basic regulatory control of the process: set production rate, maintain gas and liquid inventories, control product qualities, and avoid safety and environmental constraints. Any valves that

remain after these vital tasks have been accomplished can be utilized to enhance steady-state economic objectives or dynamic controllability (e.g. minimizes energy consumption, maximize yield, or reject disturbances).

Step 3: Establish energy management system

Make sure that energy disturbances do not propagate throughout the process by transferring the variability to the plant utility system.

We use the term energy management to describe two functions.

1. We must provide a control system that removes exothermic heats of reaction from the process. If heat is not removed to utilities directly at the reactor, then it can be used elsewhere in the process by other unit operations. This heat, however, must ultimately be dissipated to utilities.
2. If heat integration does occur between process streams, then the second function of energy management is to provide a control system that prevents the propagation of thermal disturbances and ensure the exothermic reactor heat is dissipated and not recycled. Process-to-process heat exchangers and heat-integrated unit operations must be analyzed to determine that there are sufficient degrees of freedom for control.

Heat removal in exothermic reactors is crucial because of the potential for thermal runaways. In endothermic reactions, failure to add enough heat simply results in the reaction slowing up. If the exothermic reactor is running adiabatically, the control system must prevent excessive temperature rise through the reactor.

Heat integration of a distillation column with other columns or with reactors is widely used in chemical plants to reduce energy consumption. While these designs look great in terms of steady-state economics, they can lead to complex dynamic behavior and poor performance due to recycling of disturbances. If not already included in the design, trim heater/cooler or heat exchanger bypass line must be added to prevent this. Energy disturbances should be transferred to the

plant utility system whenever possible to remove this source of variability from the process units.

Step 4: Set production rate

Establish the variable that dominate the productivity of the reactor and determine the most appropriate manipulator to control production rate. To obtain higher production rate, we must increase overall reaction rates. This can be accomplished by raising temperature, increasing reactant concentrations, increasing reactor holdup, or increasing reactor pressure. The variable we select must be dominant for the reactor

We often want to select a variable that has the least effect on the separation section but also has a rapid and direct effect on reaction rate in the reactor without hitting an operational constraint.

Step 5: Control product quality and handle safety, operational, and environmental constraints

We should select manipulated variables such that the dynamic relationships between the controlled and manipulated variables feature small time constants and dead times and large steady-state gains.

It should be note that, since product quality considerations have become more important, so it should be establish the product-quality loops first, before the material balance control structure.

Step 6: Fix a flow in every recycle loop and control inventories (pressure and level)

In most process a flow controller should be present in all liquid recycle loops. This is a simple and effective way to prevent potentially large changes in recycle flows that can occur if all flows in the recycle loop are controlled by level.

We have to determine what valve should be used to control each inventory variable. Inventories include all liquid levels (except for surge volume in certain liquid recycle streams) and gas pressures. An inventory variable should be controlled with the manipulate variable that has the largest effect on it within that unit (Richardson rule).

Gas recycle loops are normally set at maximum circulation rate, as limited by compressor capacity, to achieve maximum yields (Douglas doctrine)

Proportional-only control should be used in non-reactive level loops for cascade units in series. Even in reactor level control, proportional control should be considered to help filter flowrate disturbances to the downstream separation system.

Step 7: Check component balances

Component balances are particularly important in process with recycle streams because of their integrating effect. We must identify the specific mechanism or control loop to guarantee that there will be no uncontrollable buildup of any chemical component within the process (Downs drill).

In process, we don't want reactant components to leave in the product streams because of the yield loss and the desired product purity specification. Hence we are limited to the use of two methods: consuming the reactants by reaction or adjusting their fresh feed flow. The purge rate is adjusted to control the inert composition in the recycle stream so that an economic balance is maintained between capital and operating costs.

Step 8: Control individual unit operations

Establish the control loops necessary to operate each of the individual unit operations. A tubular reactor usually requires control of inlet temperature. High-temperature endothermic reactions typically have a control system to adjust the fuel flowrate to a furnace supplying energy to the reactor.

Step 9: Optimize economics or improve dynamic controllability

After satisfying all of the basic regulatory requirements, we usually have additional degrees of freedom involving control valves that have not been used and setpoints in some controllers that can be adjusted. These can be used either to optimize steady-state economic process performance (e.g. minimize energy, maximize selectivity) or improve dynamic response.

3.6 Plantwide Energy Management

3.6.1 Heat Exchanger Dynamics

Heat exchangers have fast dynamics compared to other unit operations in a process. Normally the time constant is measured in second but could be up to a few minutes for large exchangers. Process-to-process exchangers should be modeled rigorously by partial differential equations since they are distributed systems. This introduces the correct amount of dead time and time constant in exit stream temperatures, but the models are inconvenient to solve.

For propose of plantwide control studies it is not necessary to have such detailed descriptions of the exchanger dynamics, since these units rarely dominate the process response. Instead, it is often possible to construct useful models by letting two sets of well-stirred tanks in series heat exchanger.

3.6.2 Heat Pathways

The most of energy required for heating certain streams within the process is matched by similar amount required for cooling other streams. Heat recover from cooling a stream could be recycled back into the process and used to heat another stream. This is the purpose of heat integration and heat exchanger networks (HENs).

From a plantwide perspective we can now discern three different "heat pathways" in the process. See Figure 3.1 for an illustration. The first pathway

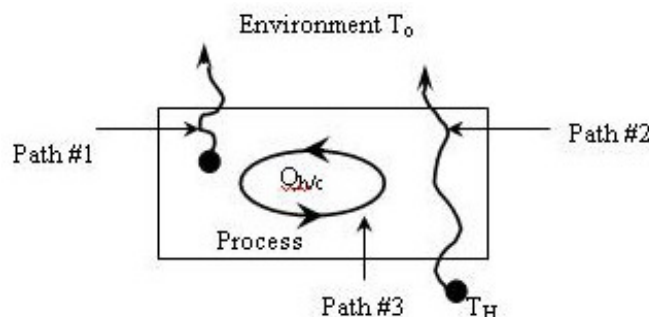

Figure 3.1: Heat pathways.

dissipates to the environment heat generated by exothermic reaction and by degradation of mechanical work (e.g. compression, pressure drop, and friction). This pathway is from inside the process and flow out. It is of course possible to convert some of the heat to work as it is removed from high temperature in the process.

A second pathway carries heat from utilities into the process. Mechanical work is extracted from the heat as it flows from a high supply way goes through the process and is needed to satisfy the thermodynamic work requirements of separation. Work is also extracted from the heat stream to overcome process inefficiencies with stream mixing and heat transfer.

The third pathway is internal to process. Here heat flows back and forth between different unit operations. The magnitude of this energy path depends upon the heating and cooling needs and the amount of heat integration implemented. Whenever the internal path is missing, and there is a heating requirement, the heat has to be supplied from utilities. The same amount of heat must eventually be rejected to the environment elsewhere in the process.

3.6.3 Heat Recovery

We can make great improvements in the plant's thermal efficiency by recycling much of the energy needed for heating and cooling process streams. There is of course a capital expense associated with improved efficiency but it can usually be justified when the energy savings are accounted for during the lifetime of the project. Of more interest to us in the current context is how heat integration

affects the dynamics and control of a plant and how we can manage energy in plants with a high degree of heat recovery.

3.6.4 Control of Utility Exchangers

The purpose of unit operation controls is to regulate the amount of energy supplied or removed. This is typically done by measuring a temperature in the process and manipulating the flowrate of utility. A PI-controller is adequate in most instances. The location of the temperature measurement depends upon the purpose of the heat exchange. The control point should be located where the effects of the added energy are felt the most. When the utility exchanger is used for stream heating and cooling, the control point is on the stream being heated or cooled.

3.6.5 Control of Process-to-Process Exchangers

Process-to-process (P/P) exchangers are used for heat recovery within a process. Most heat exchanger network are not operable at the optimum steady state design conditions; i.e., normally they can tolerate disturbances that decrease the loads but not those that increase loads and there not an adequate number of manipulative variables to be able to satisfy the process constraints and to optimize all of the significant operating variables. These types of operability limitations can be identified by using steady state considerations, and normally these operability limitations can be overcome by installing an appropriate utility exchanger and by installing bypass around the exchangers.

3.6.5.1 Use of Auxiliary Exchangers

When the P/P exchanger is combined with a utility exchanger, we also have a few design decisions to make. The utility exchanger can be installed to P/P exchanger either in series or parallel. Figure 3.2 shows the combination of P/P exchanger with a utility exchanger. Generally, the utility system of a complex energy-integrated plant is designed to absorb large disturbances in the process, and making process-to-utility exchangers relatively easy to control.

The relative sizes between the recovery and the utility exchangers must be established. From a design standpoint we would like to make the recovery exchanger large and utility exchanger small. This gives the most heat recovery, and it is also the least expensive alternative from an investment standpoint.

3.6.5.2 Use of Bypass Control

When the bypass method is used for unit operation control, we have several choices about the bypass location and the control point. Figure 3.3 shows the most common alternatives. For choosing the best option, it depends on how we define the best. Design consideration might suggest, we measure and bypass on the cold side since it is typically less expensive to install a measurement device and a control valve for cold service than it is for high-temperature service. Cost consideration would also suggest a small bypass flow to minimize the exchanger and control valve sizes.

From a control standpoint, we should measure the most important stream, regardless of temperature, and bypass on the same side as well we control (see Figure 3.3 a and c). This minimizes the effects of exchanger dynamics in the loop. We should also want to bypass a large fraction of the controlled stream since it improves the control range. This requires a large heat exchanger. There are several general heuristic guidelines for heat exchanger bypass streams. We typically want to bypass the flow of the stream whose temperature we want to control. The bypass should be about 5 to 10 percent of the flow to be able to handle disturbances. Finally, we must carefully consider the fluid mechanics of the bypass design for the pressure drops through the control valves and heat exchanger.

3.7 Heat Exchanger Network

It is generally accepted that an optimal network must feature a minimum number of units that reflects on a capital cost and minimum utility consumption that reflects on operating costs. A good engineering design must exhibit minimum capital and operating costs. For Heat Exchanger Network (HEN) synthesis, other

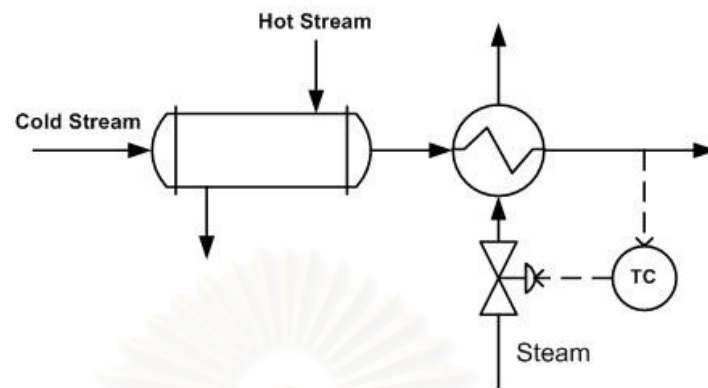

Figure 3.2: Control of process-to-process heat exchanger using the auxiliary utility.

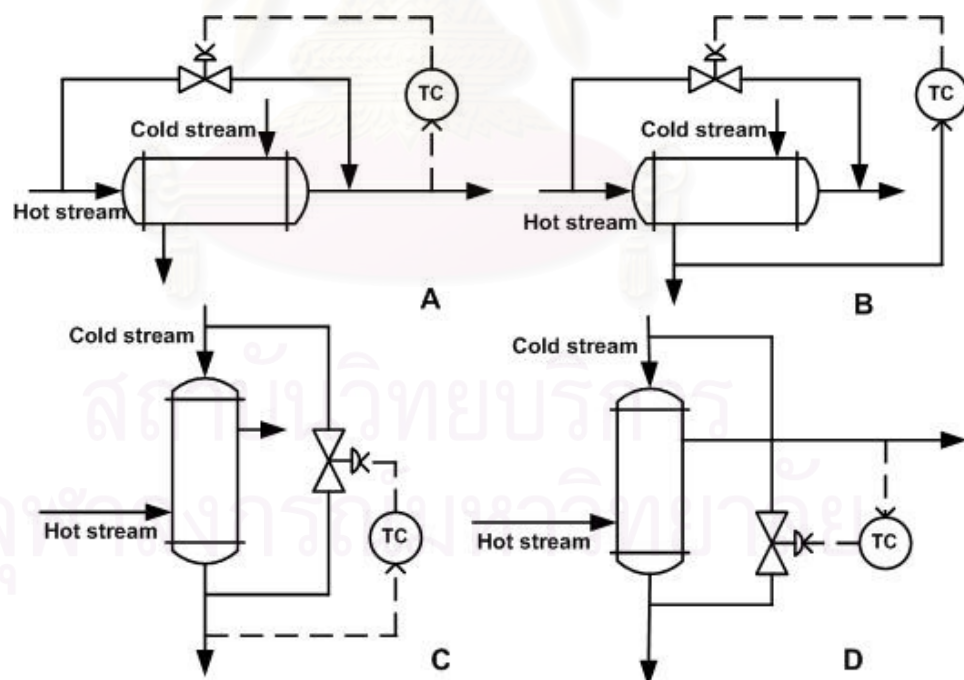

Figure 3.3: Bypass controls of process-to-process heat exchangers.

features that are usually considered in design are operability, reliability, safety, etc. in recent years the attention in HEN synthesis has been focused on the operability features of a HEN, e.g. the ability of a HEN to tolerate unwanted changes in operating conditions. It has been learned that considering only a cost objective in synthesis may lead to a worse network, i.e. a minimum cost network may not be operable at some neighboring operating conditions. The design must not only feature minimum cost, but also be able cope with a fluctuation or changes in operating conditions. The ability of a HEN to tolerate unwanted changes is called *resiliency*. It should be noted that the ability of a HEN to tolerate wanted changes is called *flexibility*.

The resiliency property of a design becomes an important feature to be accounted for when the extent of integration of a design introduces significant interactions among process components. The energy integration of a HEN generates a quite complex interaction of process streams, despite the fact that transfer of heat from hot to cold process streams is the only activity of the network. The goal of a network is to deliver the process streams to their target temperatures by using most of their heating and cooling availability and a minimum of heating and cooling utilities. The process streams are coupled through a net of heat exchangers. Changes in conditions of one stream in the network may affect the performances of many heat exchangers and the conditions of several process streams. Since resiliency is a property of a network structure.

3.7.1 Definition of HEN Resiliency

In the literature, resiliency and flexibility have been used synonymously to describe the property of HEN to satisfactorily handle variations in operating conditions. These two terms have difference in meaning.

The resiliency of a HEN is defined as the ability of a network to tolerate or remain feasible for disturbances in operating conditions (e.g. fluctuations of input temperatures, heat capacity flowrate, etc.). As mentioned before, HEN flexibility is closely in meaning to HEN resiliency, but HEN flexibility usually refers to the

wanted changes of process conditions, e.g. different nominal operating conditions, different feed stocks, etc. That is, HEN flexibility refers to the preservation of satisfactory performance despite varying conditions, while flexibility is the capability to handle alternate (desirable) operating conditions.

A further distinction between resiliency and flexibility is suggested by Colberg et al. (1989). Flexibility deals with planned, desirable changes that often have a discrete set of values, resilience deal with unplanned, undesirable changes that naturally are continuous values. Thus a flexibility is a 'multiple period' type of problem. A resilience problem should be a problem with a continuous range of operating conditions in the neighborhood of nominal operating points.

In order to make Alternative 6 of HDA plant more economically appealing, the minimum number of auxiliary utilities is identified using the proposed design scheme adapted from Wongsri's RHEN (for resilient heat exchanger network) design method.

Wongsri (1990) developed the heuristic and procedures for resilient heat exchanger network synthesis. The heuristics are used to develop basic and derived match patterns which were classified according to their (1) resiliency (2) chances that they are in solution and (3) the matching rules like the pinch method, and the thermodynamics law etc. Furthermore the same author developed for synthesize heat exchanger network called "The Disturbance Propagation Method". This method will find a resiliency network structure directly from the resiliency requirement and also feature minimum number of units and maximum energy recovery.

3.7.2 Design Conditions

There are several design conditions for resilient HEN synthesis. Usually, these are specified at extreme operating conditions. The following conditions (Wongsri, 1990) are:

1. *Nominal Operating Condition.* This is an operating condition that is ob-

tained from a steady state heat and mass balance of a process. In a good design, a network must be operated at this condition most of the time. In general, a fluctuation in operating condition is plus and minus from this point.

2. *Maximum Heat Load Condition.* This is a condition where all process streams are at their maximum heat loads. For example inlet temperatures of hot streams are the highest and of cold streams are the lowest. This is also known as the largest maximum energy recovery condition.
3. *Maximum Cooling Condition.* This is a condition where hot process streams are at their maximum heat loads whereas cold process streams are at their minimum heat loads. For example inlet temperatures of hot and cold streams are the highest.
4. *Minimum Heating Condition.* This is a condition where hot process streams are at their minimum heat loads whereas cold process streams are at their maximum heat loads. For example inlet temperatures of hot and cold streams are the lowest.
5. *Minimum Heat Load Condition.* This is a condition where all process streams are at their minimum heat loads. For example inlet temperatures of hot streams are the lowest and of cold streams are the highest. This is also known as the lowest maximum energy recovery condition.

The worst case condition of this work is the condition that minimum heat supplies by hot process stream and maximum heat demand by cold process stream. This viewpoint is shown in Figure. 3.4.

3.7.3 Match Patterns

HEN synthesis is usually considered as a combinatorial matching problem. For a HEN in which a design property is regarded as a network property, or a structure property, we need to look beyond the match level to a higher level where such a property exists, e.g. to a match structure or match pattern. Match patterns are the descriptions of the match configuration of two, possibly more process

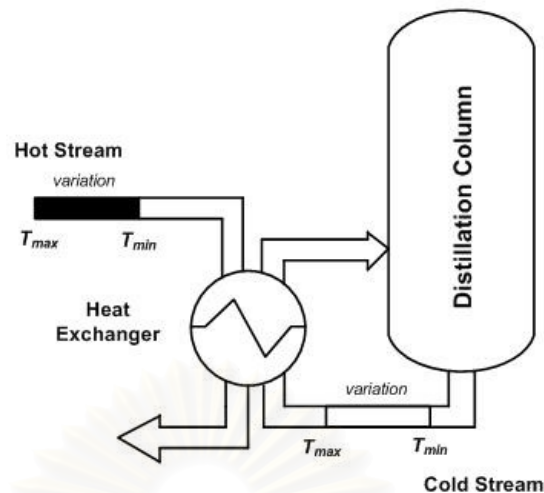

Figure 3.4: A viewpoint of worst case condition.

streams and their properties that are thermally connected with heat exchangers. Not only the match description, e.g. heat duty of an exchanger and inlet and outlet temperatures is required but also the position of a match, e.g. upstream or downstream, the magnitude of the residual heat load and the heat capacity flowrates between a pair of matched streams. So, we regard the resilient HEN synthesis problem as a match pattern combinatorial problem where more higher-level design qualities are required.

By using the 'tick off rule' there are four match patterns for a pair of hot and cold streams according to the match position and the length of streams. The four patterns are considered to the basic match pattern classes. The members of these classes are the patterns where other configurations and properties are specified. The four match pattern classes are simply called A, B, C and D and are shown in Figure 3.5 to 3.8 respectively.

1. *Class A Match Pattern:* The heat load of a cold stream is greater than the heat load of a hot stream in a pattern, i.e. the hot stream is totally serviced. The match is positioned at the cold end of the cold stream. The residual heat load is on the hot portion of the cold stream. (See Figure 3.5) A match of this class is a first type match at cold end position and the heat load of the cold stream is greater than that of the hot stream. This is a upstream

match. For a heating subproblem, a Class A match is favored, because it leaves a cold process stream at the pinch heuristics.

2. *Class B Match Pattern:* The heat load of a hot stream is greater than the heat load of a cold stream in a pattern, i.e. the cold stream is totally serviced. The match is positioned at the hot end of the hot stream. The residual heat load is on the cold portion of the hot stream. (See Figure 3.6) A match of this class is a second type match; a hot end match and the heat load of the hot stream are greater than that of the cold stream. This is an upstream match. For a cooling subproblem, a Class B match is favored, because it leaves a hot process stream at the cold end also follows the pinch heuristics.
3. *Class C Match Pattern:* The heat load of a hot stream is greater than the heat load of a cold stream in a pattern, i.e. the cold stream is totally serviced. The match is positioned at the cold end of the hot stream. The residual heat load is on the hot portion of the hot stream. (See Figure 3.7) A match of this class is a first type match; a cold end match and the heat load of the hot stream are greater than that of the cold stream. This is a downstream match.
4. *Class D Match Pattern:* The heat load of a cold stream is greater than the heat load of a hot stream in a pattern, i.e. the hot stream is totally serviced. The match is positioned at the hot end of the cold stream. The residual heat load is on the cold portion of the cold stream. (See Figure 3.8) match of this class is a second type match; a hot end match and the heat load of the cold stream is greater than that of the hot stream. This is a downstream match.

When the residual heat load in a match pattern is matched to a utility stream, it is closed or completed pattern. Otherwise, it is an open or incomplete pattern. It can be seen that if the heat load of the residual stream is less than the minimum heating or cooling requirement then the chances that the match pattern will be matched to a utility stream is high.

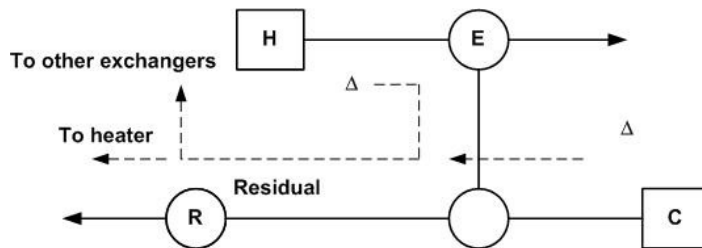

Figure 3.5: Class A Match Pattern.

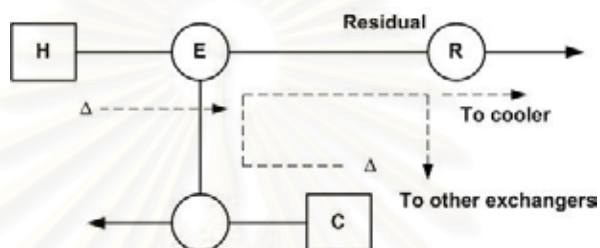

Figure 3.6: Class B Match Pattern.

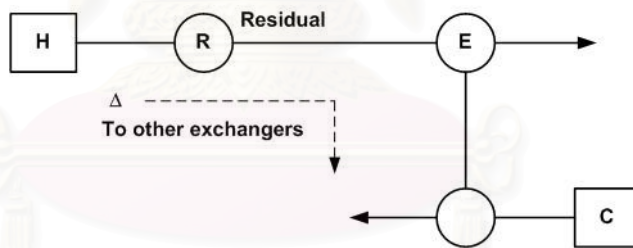

Figure 3.7: Class C Match Pattern.

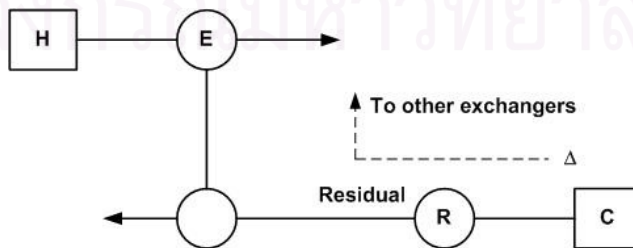

Figure 3.8: Class D Match Pattern.

CHAPTER IV

HDA PROCESS

4.1 Process Description

The hydrodealkylation HDA of toluene process (Alternative1) by Douglas (1988) on conceptual design as in Figure 4.1 contain nine basic unit operations: reactor, furnace, vapor-liquid separator, recycle compressor, two heat exchangers, and three distillation columns. Two raw materials, hydrogen, and toluene, are converted into the benzene product, with methane and diphenyl produced as by-products. The two vapor-phase reactions are

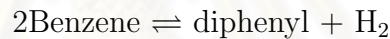
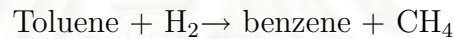

The kinetic rate expressions are functions of the partial pressure (in psia) of toluene p_T , hydrogen p_H , benzene p_B , and diphenyl p_D , with an Arrhenius temperature dependence. Zimmerman and York (1964) provide the following rate expression

$$r_1 = 3.6858 \times 10^6 \exp\left(\frac{-25616}{T}\right) p_T p_H^{1/2} \quad (4.1)$$

$$r_2 = 5.987 \times 10^4 \exp\left(\frac{-25616}{T}\right) p_B^2 - 2.553 \times 10^5 \exp\left(\frac{-25616}{T}\right) p_D p_H \quad (4.2)$$

Where r_1 and r_2 have units of $\text{lb}^*\text{mol}/(\text{min}*\text{ft}^3)$ and T is the absolute temperature in Kelvin. The heats of reaction given by Douglas (1988) are -21500 Btu/lb* mol of toluene for r_1 and 0 Btu/lb* mol for r_2 .

The effluent from the adiabatic reactor is quenched with liquid from the separator. This quenched stream is the hot-side feed to the process-to-process heat exchanger, where the cold stream is the reactor feed stream prior to the furnace. The reactor effluent is then cooled with cooling water and the vapor (hydrogen, methane) and liquid (benzene, toluene, diphenyl) are separated. The vapor stream

from the separator is split and the remainder is sent to the compressor for recycle back to the reactor.

The liquid stream from the separator (after part is taken for the quench) is fed to the stabilizer column, which has a partial condenser component. The bottoms stream from the stabilizer is fed to the product column, where the distillate is the benzene product from the process and the bottoms is toluene and diphenyl fed to the recycle column. The distillate from the recycle column is toluene that is recycled back to the reactor and the bottom is the diphenyl byproduct.

Makeup toluene liquid and hydrogen gas are added to both the gas and toluene recycle streams. This combined stream is the cold-side feed to the process-to-process heat exchanger. The cold-side exit stream is then heated further up to the required reactor inlet temperature in the furnace, where heat is supplied via combustion of fuel. Six alternatives HENs for the HDA process had been generated (Terril and Douglas, 1987). Alternative 1 has simply an enlarged FEHE (Tables 4.1 to 4.4 contain data for selected process streams, Table 4.5 presents equipment data and Table 4.6 compiles the heat transfer rates within process equipment). Alternative 2 is the same as Alternative 1, except the recycle column is pressure shifted to be above the pinch temperature, and the condenser for the recycle column is used to drive the product column reboiler. All of the other alternatives also include this pressure shifting. In Alternative 3, the reactor effluent is used to drive the stabilizer column reboiler, whereas in Alternative 4 the reactor effluent is used to drive the product column reboiler. For Alternative 5, the reactor effluent stream is used to drive both the stabilizer column reboiler and the product column reboiler consecutively. Alternative 6 is the most complex one, since it consists of three FEHEs and all the reboilers in the three columns are driven by the reactor effluent stream.

The benefit obtained from energy integration with the base case flowrate for the six alternatives is given in Table 4.7. The energy saving from the energy integration fall between 29 and 43 percent, but the cost saving are in the range from -1 to 5 percent. The cost saving are not as dramatic the raw material costs

dominate the process economics.

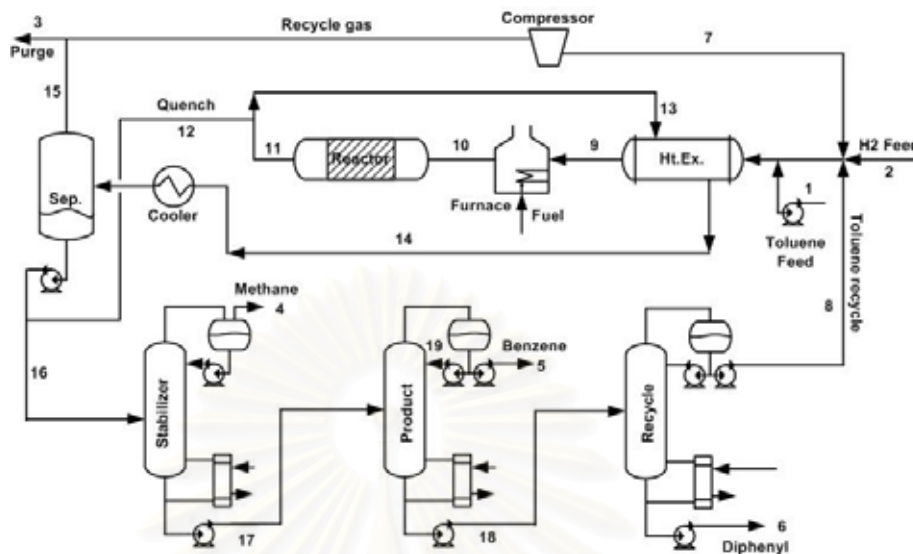

Figure 4.1: Hydrodealkylation of toluene process (Alternative 1).

4.2 Plantwide control strategies

Step 1. Establish Control Objectives

For this process, the essential is to produce pure benzene while minimizing yield losses of hydrogen and diphenyl. The reactor feed ratio of hydrogen to aromatics must be greater than 5:1. The reactor effluent gas must be quenched to $1150^{\circ}F$

Step 2. Determine Control Degree of Freedom

There are 23 control degrees of freedom. They include; two fresh feed valves for hydrogen and toluene, purge valve, separator base and overhead valves, cooler cooling water valve, liquid quench valve, furnace fuel valve, stabilizer column steam, bottoms, reflux, cooling water, and vapor product valves; product column steam, bottoms, reflux, distillate, and cooling water valves; and recycle column steam, bottoms, reflux, distillate, and cooling water valves.

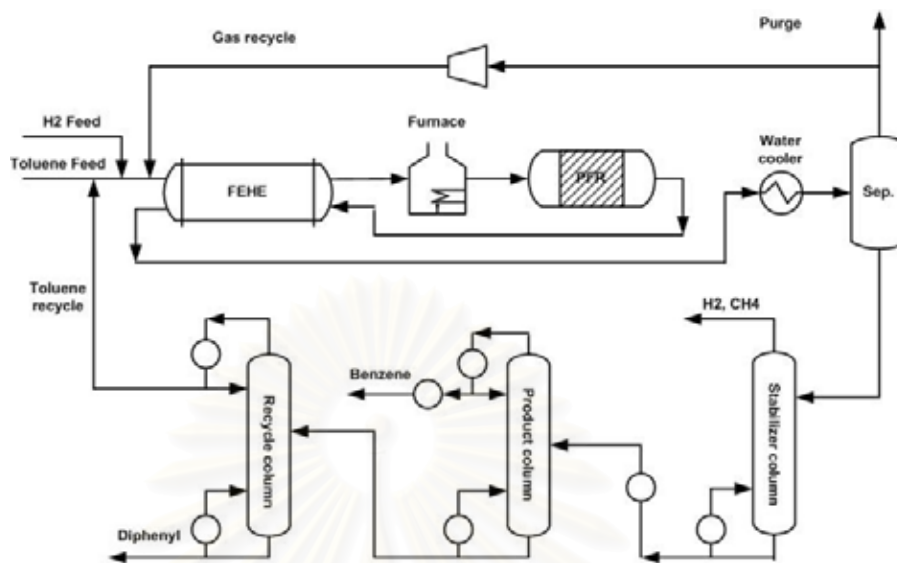

Figure 4.2: HDA process (Alternative 1).

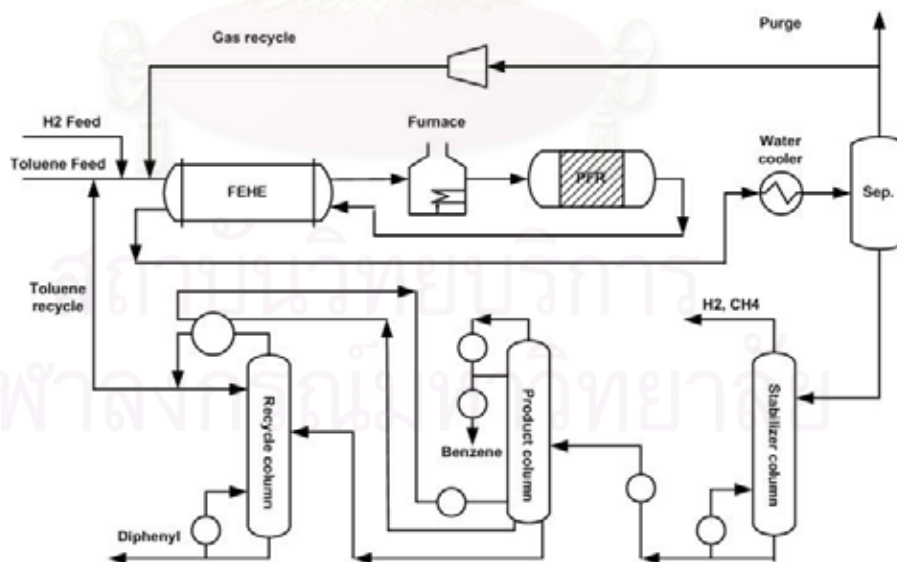

Figure 4.3: HDA process (Alternative 2).

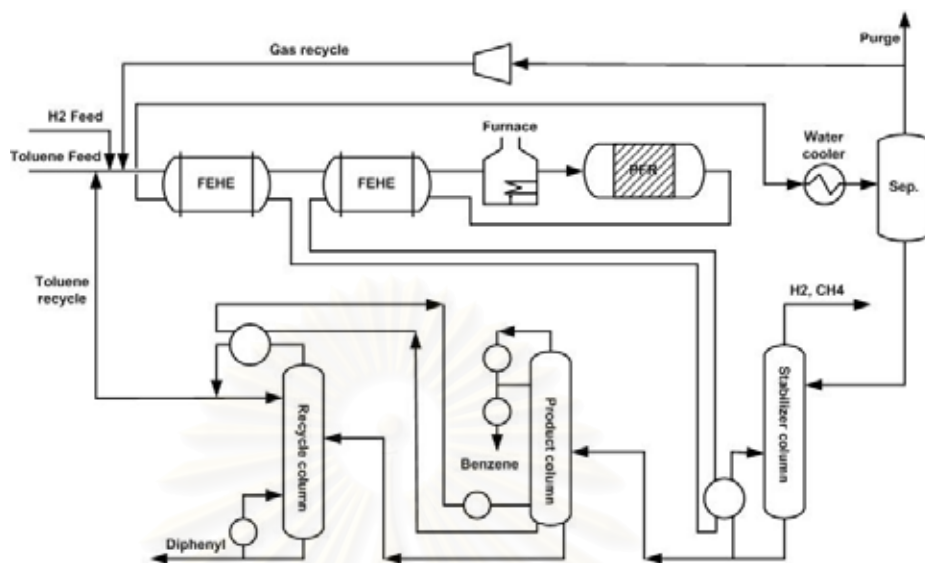

Figure 4.4: HDA process (Alternative 3).

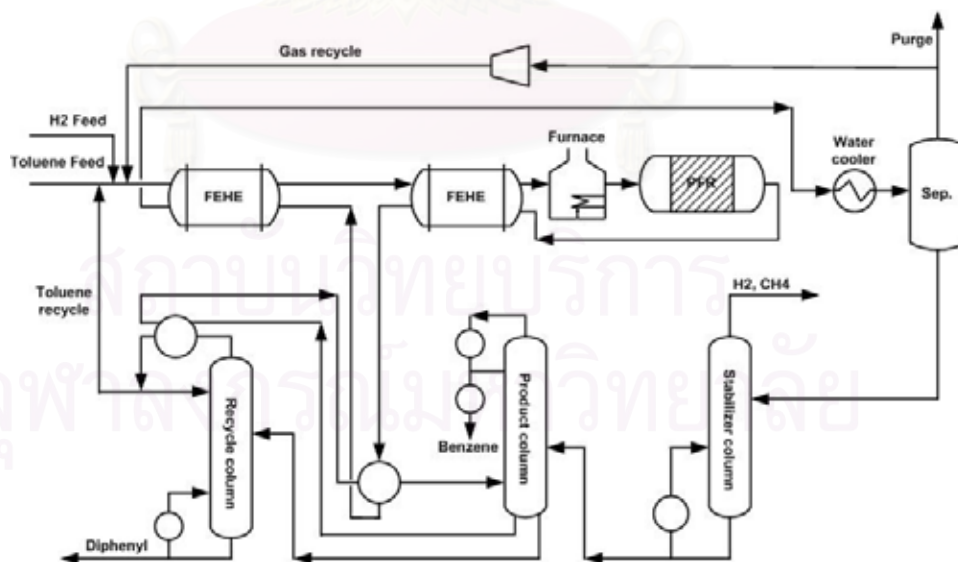

Figure 4.5: HDA process (Alternative 4).

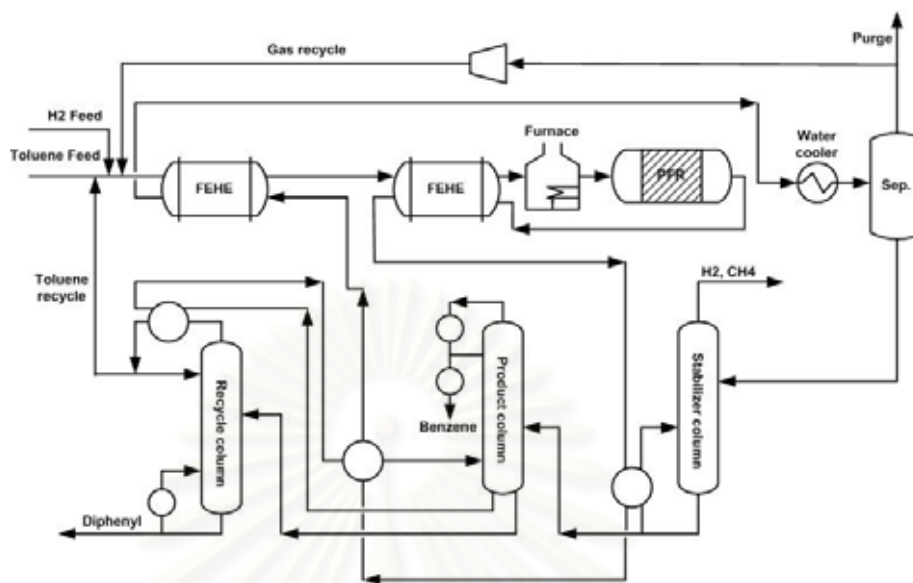

Figure 4.6: HDA process (Alternative 5).

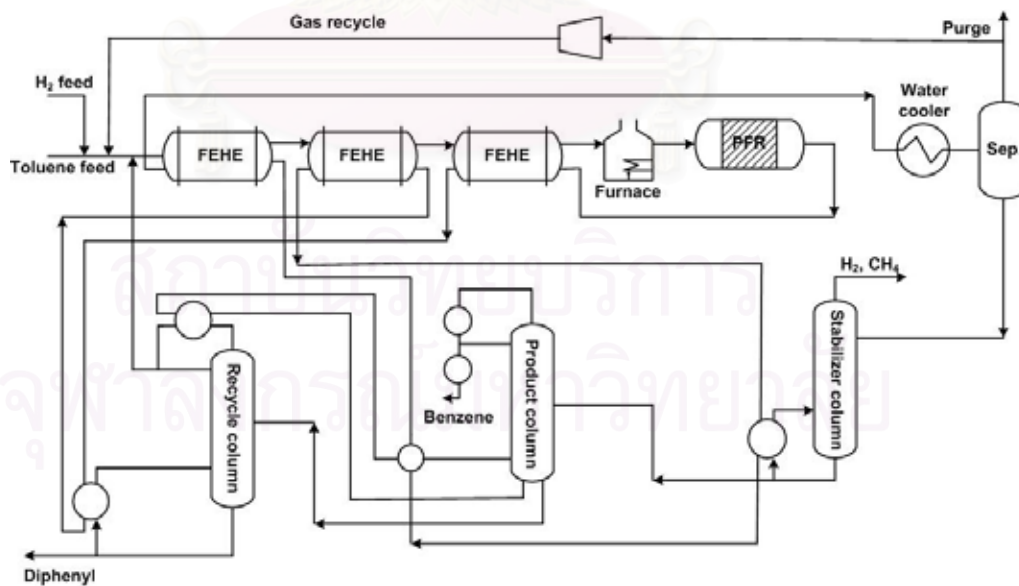

Figure 4.7: HDA process (Alternative 6).

Table 4.1 Process stream data, part 1

	Fresh toluene	Fresh hydrogen	Purge gas	Stabilizer gas	Benzene product	Diphenyl Product
Stream number	1	2	3	4	5	6
Flow (lb.mol/h)	290.86	490.38	480.88	21.05	272.5	6.759
Temperature (°F)	86	86	115	113	211	559
Pressure (psia)	575	575	480	480	30	31
H ₂ , mole fraction	0	0.97	0.3992	0	0	0
CH ₄	0	0.03	0.5937	0.9349	0	0
C ₆ H ₆	0	0	0.0065	0.0651	0.9997	0
C ₇ H ₈	1	0	0.0006	0	0.0003	0.00026
C ₁₂ H ₁₀	0	0	0	0	0	0.99974

Table 4.2 Process stream data, part 2

	Gas recycle	Toluene recycle	Furnace inlet	Reactor inlet	Reactor effluent	Quench
Stream number	7	8	9	10	11	12
Flow (lb.mol/h)	3519.2	82.14	4382.5	4382.5	4382.5	156.02
Temperature (°F)	115	272	1106	1150	1263.2	113
Pressure (psia)	513	30	513	503	486	486
H ₂ , mole fraction	0.3992	0	0.4291	0.4291	0.3644	0
CH ₄	0.5937	0	0.4800	0.4800	0.5463	0.0515
C ₆ H ₆	0.0065	0.00061	0.0053	0.0053	0.0685	0.7159
C ₇ H ₈	0.0006	0.00037	0.0856	0.0856	0.0193	0.2149
C ₁₂ H ₁₀	0	0.00002	0	0	0.0015	0.0177

Table 4.3 Process stream data, part 3

	FEHE Hot in	FEHE Hot out	Separator Gas out	Stabilizer feed	Stabilizer bottoms	Product bottoms
Stream number	13	14	15	16	17	18
Flow (lb.mol/h)	4538.5	4538.5	4156	382.5	361.4	88.91
Temperature (°F)	1150	337	113	113	200	283
Pressure (psia)	486	480	486	480	480	33
H ₂ , mole fraction	0.3518	0.3518	0.3992	0	0	0
CH ₄	0.5294	0.5294	0.5397	0.0515	0	0
C ₆ H ₆	0.0907	0.0907	0.0065	0.7159	0.7538	0.0006
C ₇ H ₈	0.0260	0.0260	0.0006	0.2149	0.2275	0.9234
C ₁₂ H ₁₀	0.0021	0.0021	0	0.0177	0.0187	0.0760

Table 4.4 Process stream data, part 4

	Product column reflux	Recycle column reflux
Stream number	19	20
Flow (lb.mol/h)	300	12
Temperature (°F)	211	272
Pressure (psia)	30	30
H ₂ , mole fraction	0	0
CH ₄	0	0
C ₆ H ₆	0.9997	0.00061
C ₇ H ₈	0.0003	0.99937
C ₁₂ H ₁₀	0	0.00002

Step 3. Establish Energy management system

The product benzene is produced from the exothermic reaction between hydrogen and toluene at $1158^{\circ}F$. The reactor operates adiabatically, so for a given reactor design the exit temperature depends upon the heat capacities of the reactor gases, reactor inlet temperature, and reactor conversion. Heat from the adiabatic reactor is carried in the effluent stream and is not removed from the process until it is dissipated to utility in the separator cooler.

Energy management of reaction section is handled by controlling the inlet and exit streams temperature of the reactor for preventing the benzene yield decreases from the side reaction. In the reference control structure, quenched stream is used for control temperature at the design value and for saving cost from the cooling utility. However, this method makes the path of disturbance propagation to the separation section, so the product purity control must be tighter because of component inventories changing. The alternative way is using of the heuristic laws; Montree (2000) introduces about the energy management that "Decreasing the effect of heat integration in the process can be done by remove the energy as much as possible". Therefore, the cooling utility should be used for controlling the reactor exit temperature and preventing the disturbance propagation to the separation section as the second control structure. Another energy control loop is using of the cooling utility for removing excess heat from the heat exchanger to reach the optimal temperature in the separator.

Table 4.5 Equipment data and specifications

Unit operation	Property	Size
Reactor	Diameter	9.53 ft
	Length	57 ft
FEHE	Area	30000 ft ²
	Shell volume	500 ft ³
	Tube volume	500 ft ³
Furnace	Tube volume	300 ft ³
Separator	Liquid volume	40 ft ³
Stabilizer column	Total theoretical trays	6
	Feed tray	3
	Diameter	4.3 ft
	Reflux drum liquid holdup	7 ft ³
	Column base liquid holdup	250 ft ³
Product column	Total theoretical trays	27
	Feed tray	15
	Diameter	5 ft
	Theoretical tray holdup	2.1 lb.mol
	Efficiency	50%
	Reflux drum liquid holdup	25 ft ³
	Column base liquid holdup	30 ft ³
Recycle column	Total theoretical trays	7
	Feed tray	5
	Diameter	3 ft
	Theoretical tray holdup	1 lb.mol
	Efficiency	30%
	Reflux drum liquid holdup	100 ft ³
	Column base liquid holdup	15 ft ³

Table 4.6 Heat transfer rates

Unit Operation	Power (MW)
FEHE	19.400
Furnace	0.984
Separator condenser	5.470
Product reboiler	2.180
Product condenser	2.050
Recycle reboiler	0.439
Recycle condenser	0.405
Reactor heat generation	1.830

Table 4.7 Energy integration for HDA process

	Base case	Alternatives					
		1	2	3	4	5	6
1. TAC (\$10 ⁶ /yr), base case flows	6.38	6.4	6.45	6.38	6.11	6.04	6.03
2. Utilities usage (MW), base case flows	12.7	9.06	7.68	7.34	7.30	7.30	7.30
3. Energy saving (%)		29	40	42	43	43	43
4. Cost saving (%)		-0.3	-1	0	4	5	5

Step 4. Set Production Rate

There are not constrained to set production either by supply or demand, then the production rate can be set by benzene production. Considering of the kinetics equation is found that the three variables alter the reaction rate; pressure, temperature and toluene concentration which is the limiting agent.

- Pressure control of the compressor operates at maximum capacity for yield purposes.
- Reactor inlet temperature is controlled by specify the reactant fresh feed rate and reactant composition into the reactor. The reactor inlet temperature is constrained below 1300°F for preventing the cracking reaction that produces undesired byproduct.

- Toluene inventory can be controlled in two ways. First, liquid level at the top of recycle column is measured to change toluene feed flow as the reference control structure. Second, toluene flow in the system is measured for control amount of toluene feed flow as the first control structure. The second way gives the less process time constant than the first, then the response of the first control structure faster than reference control structure.

Step 5. Control Product Quality and Handle Safety, Operational, and Environmental Constraints

Benzene purity must be maintained at 99.97 percent for this research. Any methane that leaves in the bottoms of the stabilizer column contaminates the benzene product. The separation in the stabilizer column prevents the problem by using a temperature to set column steam rate (boilup). Toluene in the overhead of the product column also affects benzene quality. Benzene purity can be controlled by manipulating the column steam rate (boilup) to maintain temperature in the column.

Step 6. Control Inventories and Fix a Flow in Every Recycle Loop

In most processes a flow control should be present in all recycle loops. This is a simple and effective way to prevent potentially large changes in recycle flows, while the process is perturbed by small disturbance. We call this high sensitivity of the recycle flowrates to small disturbances the "snowball effect". There are two recycle control loops in this research; reference control structure and the first control structure.

Four pressures and seven liquid levels must be controlled in this process. For the pressures, there are in the gas loop and in the three distillation columns. In the gas loop, the separator overhead valve is opened and run the compressor at maximum gas recycle rate to improve yield so the gas loop control is related to the purge stream and fresh hydrogen feed flow. In the stabilizer column, vapor product flow is used to control pressure. In the product and recycle columns, pressure control can be achieved by manipulating cooling water flow to regulate overhead condensation rate.

For liquid loops, there are a separator and two (base and overhead receiver) in each column. The most direct way to control separator level is with the liquid flow to the stabilizer column. The stabilizer column overhead level is controlled with cooling water flow and base level is controlled with bottoms flow. In the product column, distillate flow controls overhead receiver level and bottoms flow controls base level. In the recycle column, the first control structure the total toluene flow to control level, while the reference control structure use the fresh toluene feed flow to control level. The base level of recycle column is controlled by manipulating the column steam flow because it has much larger effect than bottoms flow.

Step 7. Check Component Balances

Component balances control loops consists of:

- Methane is purged from the gas recycle loop to prevent it from accumulating and its composition can be controlled with the purge flow.
- Diphenyl is removed in the bottoms stream from the recycle column, where steam flow controls base level.
- The inventory of benzene is accounted for by temperature and overhead receiver level control in the product column.
- Toluene inventory is accounted for by level control in the recycle column overhead receiver.
- Gas loop pressure control accounts for hydrogen inventory.

Step 8. Control Individual Unit Operations

The rest degrees of freedom are assigned for control loops within individual units. These include:

- Cooling water flow to the cooler controls process temperature to the separator.
- Refluxes to the stabilizer, product, and recycle columns are flow controlled.

Step 9. Optimize Economics or Improve Dynamic Controllability

The basic regulatory strategy has now been established. Some freedom is used to select several controller set points to optimize economics and plant performance. Such as, the set point for the methane composition controller in the gas recycle loop must balance the trade-off between yield loss and reactor performance. Reflux flows to the stabilizer, product, and recycle columns must be determined based upon column energy requirement and potential yield losses of benzene (in the overhead of the stabilizer and recycle columns) and toluene (in the base of the recycle column).

4.3 Steady-State Modeling

First, a steady-state model is built in HYSYS.PLANT, using the flowsheet and equipment design information, mainly taken from Douglas (1988) and Luyben et al. (1998) in above tables. For our simulation, Peng-Robinson model is selected for physical property calculation because of its reliability in predicting the properties of most hydrocarbon-based fluids over a wide range of operating conditions. The reaction kinetics of both reactions are modeled with standard Arrhenius kinetic expressions available in HYSYS.PLANT, and the kinetic data are taken from Luyben et al. (1998). Since there four material recycles, four RECYCLE operations are inserted in the streams, Hot-In, Gas-Recycle, Quench, and Stabilizer-Feed. Proper initial value should be chosen for these streams, otherwise the iterative calculations might converge to another steady-state due to the non-linearity and unstable characteristics of the process. When the columns are modeled in steady-state, besides the specification of inlet streams, pressure profiles, number of trays and feed tray, two specifications need to be given for columns with both reboiler and condenser. These could be the duties, reflux rate, draw stream rates, composition fractions, etc. We chose reflux ratio and overhead benzene mole fraction for the stabilizer column. For the remaining two columns, bottom and overhead composition mole fractions are specified to meet the required purity of products given in Douglas (1988). The tray sections of the columns are calculated using the tray sizing utility in HYSYS, which calcu-

lates tray diameters, based on Glitsch design parameters for valve trays. Though the tray diameter and spacing, and weir length and height are not required in steady-state modeling, they are required for dynamic simulation.



สถาบันวิทยบริการ
จุฬาลงกรณ์มหาวิทยาลัย

CHAPTER V

DESIGN OF WORKABLE HEAT-INTEGRATED HDA PROCESS AND STEADY STATE SIMULATION

5.1 Design of Workable Complex Heat-Integrated HDA Process

The purpose of this chapter is to illustrate the strategy that is used to design the Alternative 6 of HDA plant with minimum auxiliary reboilers, comprising of 2 steps, is described as follows:

1. *Determine the disturbances and their magnitudes.* In this step, we illustrate the strategy that is used to design the worst case condition for Alternative 6 of HDA process. The disturbance load requirement is determined in this step. Only temperature variation is considered here.

First, we notice that the process streams can be classified into two categories. They are the "independent streams" (H1 and C4, see Figure 5.1) and the "dependent stream" (H2, C1, C2, and C3). By independent streams, we meant the streams that their inlet temperatures can be arbitrary adjusted. Let the variation is 10 Celsius. By steady-state simulation, the resulting temperatures of dependent streams (the bottoms of the 3 columns, and the distillate of the recycle column) are ranged from 1.1 to 24.7 Celsius (see Table 5.1). To be conservative, we let the lowest temperature of the dependent streams be 5 Celsius below their nominal values, except the bottom temperature of the recycle column which is 24.7 Celsius lower than its nominal value. This is probably unlikely to happen, so its lowest temperature is kept at this value.

2. *Design the Alternative-6 HDA with minimum auxiliary reboilers.* In this step, the process stream data and expected disturbance data from step 1

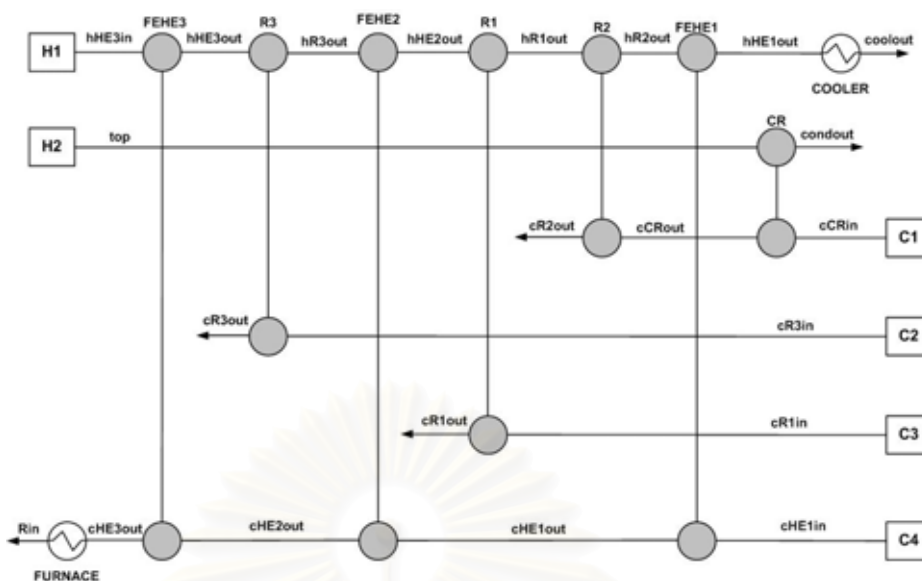

Figure 5.1: Heat Exchanger Network (HEN) of HDA process (Alternative 6).

are used to design resilient heat exchanger network. Heat pathways of hot streams (heat loads) to cold streams is shown in Figure 5.2 and the heat supply and demand of each process stream is shown in Table 5.2. We found that only 1 auxiliary reboiler is needed instead of 3 for the 3 columns. A resilient heat exchanger network scheme is shown in Figure 5.3.

5.2 Steady State Simulation

In order to guarantee a workable process, the worst case condition is made. We can evaluate the performance of our design of the Alternative 6 of HDA process with minimum auxiliary reboilers by using HYSYS simulator. Figure 5.4 and Figure 5.5 show HYSYS flowsheet of the steady state modeling of HDA process with three auxiliary reboilers scheme (introduced by Luyben, 1999) and with minimum auxiliary reboilers scheme (our study) respectively.

From the simulation results at worst case condition, our design guarantee that it is workable despite only an auxiliary reboiler. Note that the furnace duty of the structure with minimum auxiliary reboiler is greater than the Luyben's structure by 5.57 percent since the furnace must provide the auxiliary heating.

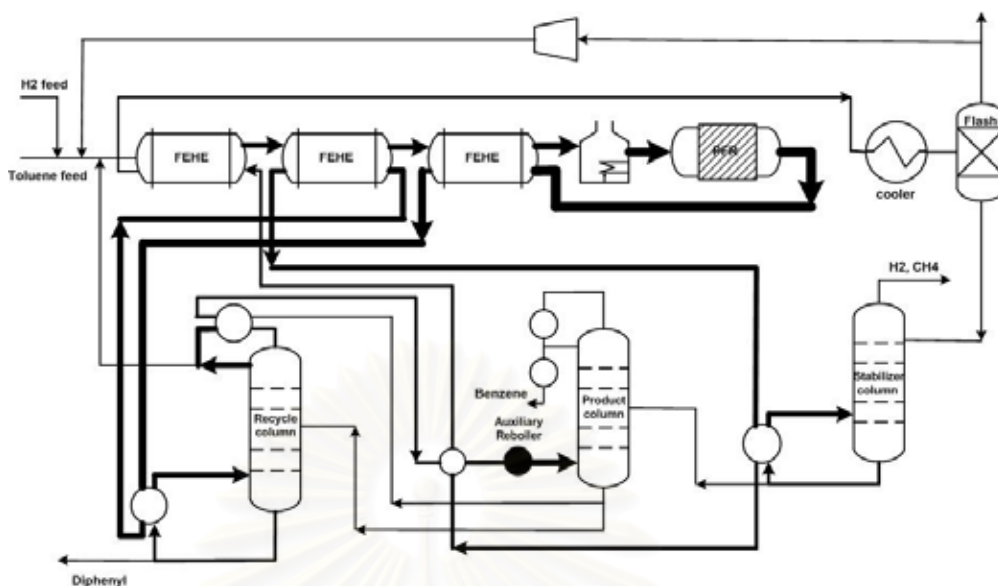

Figure 5.2: Heat Pathways of HDA process (Alternative 6).

Table 5.1 The changes of the temperature of dependent streams.

Independent Stream		Dependent Stream			
H1	C4	H2	C1	C2	C3
ΔT (Celsius)					
611.1 (-10)	-	1.1	2.1	24.7	3.3
631.1 (+10)	-	52.2	7.3	0.5	1.7
Nominal Temperature (Celsius)					
621.1	69.6	183.3	144.3	349.4	189.9
Inlet Temperature at Worst Case Condition (Celsius)					
611.1	59.6	178.3	139.3	324.7	184.9

Table 5.2 An amount of energy of HDA-6 process at worst case condition.

Hot Stream		Cold Stream		
Heat Supply (kW)	Temperature (Celsius)	Heat Demand (kW)	T _{in} (Celsius)	T _{out} (Celsius)
18296	606.4	6829	211.8	435.8
11467	450	701.5	324.7	350.7
10766	404.1	2151	141.9	211.8
8615	340.5	1532	184.9	215
7083	293	3313	59.6	141.9
3770*	165.9	3930	159.6	193

* we need auxiliary heating from auxiliary reboiler to be 160 kW

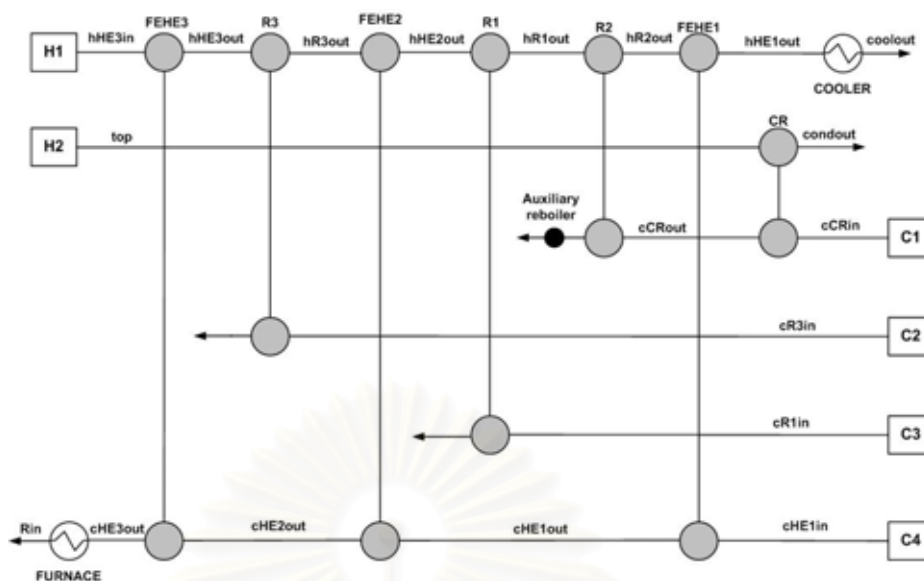

Figure 5.3: Resilient Heat Exchanger Network (RHEN) of HDA process.

The energy rate of furnace, cooler, and auxiliary reboilers are shown in Table 5.3.

In this work, the cost estimation is used for to compare the equipment cost of the plant with minimum auxiliary reboilers and the plant with three auxiliary reboilers (introduced by Luyben, 1999).

The capital equipment-costing program CAPCOST is chosen for cost estimation of the hydrodealkylation (HDA) of toluene process with minimum auxiliary reboilers (See appendix A). This program is based on the module factor approach to costing that was originally introduced by Guthrie (1969) and modified by Ulrich (1984). The essential data for this program are the capacity or size parameter, the operating condition, and the material for the equipment. In addition, we must update the value for the Chemical Engineering Plant Cost Index (CEPCI) before using this program.

From Table 5.3, the furnace of our design is bigger. However, the capital cost of the total plant is lower. At the worst case condition, the capital cost of the plant of our design is decreased by 7.21 percent. The capital cost of HDA plants is shown in Table 5.4.

Table 5.3 The energy rate of furnace, cooler, and auxiliary reboilers.

Structure Name	Q_{furnace} (kW)	Q_{cooler} (kW)	Q_{AR1} (kW)	Q_{AR2} (kW)	Q_{AR3} (kW)
Luyben's structure	5835	1695	162.7	191.2	147
Our design	6160	1679	-	160.2	-

Table 5.4 The capital cost of HDA plants.

Name	Bare Module Cost (\$)	
	Structure Name	
	Our design	Luyben's structure
FEHE1	156000	156000
FEHE2	155000	155000
FEHE3	154000	154000
R1	152000	152000
R2	152000	152000
R3	152000	152000
CR	139000	139000
Furnace	717000	684000
AR1	-	89000
AR2	89000	90000
AR3	-	88000
Total	1866000	2011000

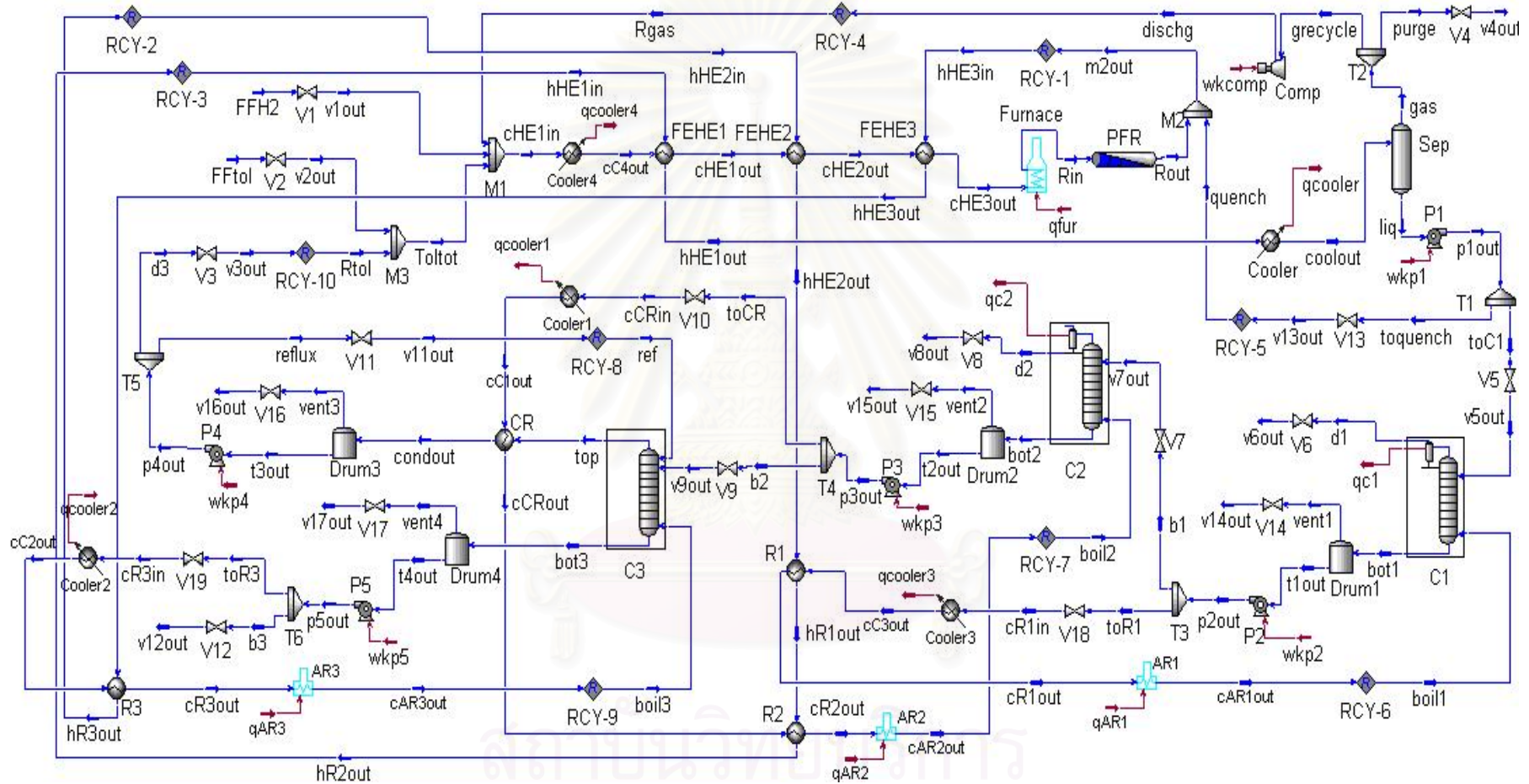

Figure 5.4: HYSYS flowsheet of HDA process (Alternative 6) with three auxiliary reboilers

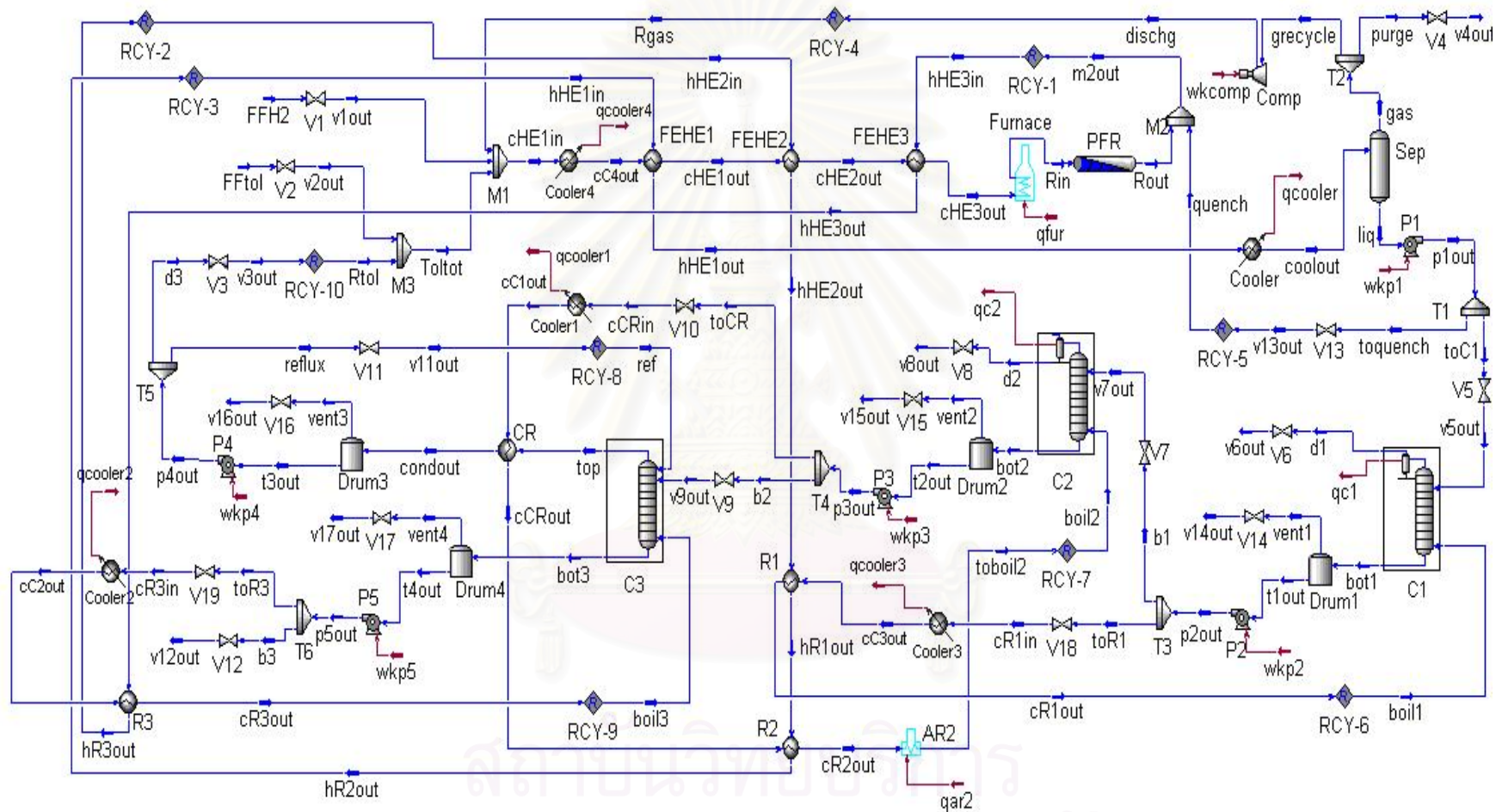

Figure 5.5: HYSYS flowsheet of HDA process (Alternative 6) with minimum auxiliary reboiler (our design)

CHAPTER VI

CONTROL STRUCTURES AND DYNAMIC SIMULATION

The essential task of plantwide control for a complex plant consists of recycle streams and energy integration is maintaining the plant energy and mass balances. As the operating condition changes, the control system is needed to reject loads and regulate an entire process into a design condition to achieve its objectives. Therefore, our purpose of this chapter is to present the new control structures of HDA process with energy integration (Alternative 6). In addition, the three new designed control structures are also compared with the prior work based on rigorous dynamic simulation using the commercial software HYSYS.

6.1 Design of plantwide Control for HDA Process with three Auxiliary Reboilers: Base Case

The plantwide control systems for the HDA process is developed based on the HPH. However, the designed control systems must achieve certain control objectives within prescribed operational constraints. The control objectives for this process are typical for a chemical processes and listed below:

1. Maintain process variables at desired values
2. Keep process operating conditions within equipment constraints
3. Minimize variability of the product rate and the product quality during disturbances
4. Minimize the disturbance propagation

For the HDA process, several constraints are given by Douglas (1988). These include:

1. The reactor feed ratio of hydrogen to aromatic feed must be greater than 5:1 to prevent coking.
2. The reactor outlet temperature must be less than 704°C to prevent hydro-cracking.
3. The reactor effluent must be quenched to 621.1°C with liquid from separator to prevent fouling in the process-to-process heat exchanger.
4. The conversion must be less than 0.97 for the product distribution correlation.

The plantwide control structure for heat-integrated HDA process with three auxiliary reboilers is shown in Figure 6.1. Since the hot reactor product is used to drive all reboilers in stabilizer, product and recycle column. In order to obtain a good performance, Luyben et al. (1999) suggested adding three auxiliary reboilers in the HDA process. In this control structure, the auxiliary reboiler duties are manipulated to control the tray temperatures in the three columns. The hot outlet temperatures of FEHE 2 and FEHE 3 (the temperature at the entrance of the auxiliary reboilers, R2 and R3 respectively) are controlled by manipulating bypass valve on the cold stream to prevent the propagation of thermal disturbance to the separation section. In the recycle column, the cold inlet stream of condenser/reboiler (CR) is bypassed and manipulated to control its pressure column. In addition, the averaging tray temperature control in the recycle column is used instead of a single tray temperature control in order to reduce the deviation of temperature response during the disturbance occur. The initial values of all of the controlled and manipulated variables come from steady state simulation and listed in Table 6.1. The control structures and parameter controllers are shown in Table C.1. In this work, the type of controller for each control loop is different. P controllers are employed for the level loops, PID controllers are employed for the temperature loops and PI controllers are employed for the remaining loops.

6.1.1 Dynamic Simulation Results for HDA Process with three Auxiliary Reboilers: Base Case

In order to illustrate the dynamic behavior of the control structure in HDA process Alternative 6, several disturbance loads are made. The dynamic responses of the control system are shown in Figures 6.2 to 6.7. Results for individual disturbance load changes are as follows:

6.1.1.1 Change in the Disturbance Load of Cold Stream (Reactor Feed Stream)

Figure 6.2 shows the dynamic responses to a change in the disturbance load of cold stream (reactor feed stream). This disturbance is made as follows: first the fresh toluene feed temperature is decreased from 30°C to 20°C at time equals 10 minutes, and the temperature is increased from 20°C to 40°C at time equals 100 minutes, then its temperature is returned to its nominal value of 30°C at time equals 200 minutes.

Both the cold and hot outlet temperatures of FEHE1 decrease as the cold inlet temperature decreases. As a result, the hot outlet temperature of FEHE1 drops to a new steady state value and the cooler duty decreases. The positive disturbance load of the cold stream will result in increase of the small furnace duty (Figure 6.2.k, l and m).

When the cold inlet temperature of FEHE1 increases, both the cold and hot outlet temperatures of FEHE1 increase. Again, the hot outlet temperature of FEHE1 quickly increases to a new steady state value, so the cooler duty increases. The negative disturbance load of the cold stream will result in decrease of the small furnace duty.

The separator temperature and the tray temperature in the product column are well controlled (Figure 6.2.d and f), but the oscillations occur in the reactor inlet temperature and the tray temperature in the stabilizer column (Figure 6.2.c and e). For the tray temperature in the recycle column, it has a small

deviation about 0.3°C and it takes more than 400 minutes to return to its nominal value of 326.7°C (Figure 6.2.g).

6.1.1.2 Change in the Disturbance Load of Cold Stream from the Bottoms of Stabilizer Column

Figure 6.3 shows the dynamic responses of HDA process alternative 6 to a change in the disturbance load of cold stream which originating from the bottoms of the stabilizer column, by changing its temperature from 190°C to 188°C at time equals 10 minutes, and its temperature is increased from 188°C to 192°C at time equals 200 minutes, then its temperature is returned to its nominal value of 190°C at time equals 400 minutes.

Both the positive and negative disturbance loads of the cold stream from the bottoms of the stabilizer column are shifted to the hot stream. The positive disturbance load (i.e. when the temperature decreases) will decrease the hot inlet temperature of FEHE1 (i.e. become a negative disturbance load for the hot stream).

As a result, the hot outlet temperature of FEHE1 and the inlet temperature of the furnace drop to a new steady state value (Figure 6.3.j and l). Thus, they will result in decrease of the cooler duty and increase of the furnace duty, respectively (Figure 6.3.k and m). On the other hand, when the temperature of the cold stream increases, its negative disturbance load causes a positive disturbance load for the hot stream. As a result, the hot outlet temperature of FEHE1 increase, So it will result in increase of the cooler duty and the furnace duty decreases, since the furnace inlet temperature increases.

6.1.1.3 Change in the Disturbance Load of Cold Stream from the Bottoms of Product Column

Figure 6.4 shows the dynamic responses of HDA process to a change in the disturbance load of cold stream from the bottoms of the product column, by changing its temperature from 144°C to 142°C at time equals 10 minutes, and

the its temperature is increased from 142°C to 146°C at time equals 200 minutes, then its temperature is returned to its nominal value of 144°C at time equals 400 minutes.

Principally, to shift of both positive and negative disturbance loads originating from the bottoms of product column are the same as those originating from the bottoms of the stabilizer column. Again, when the temperature decreases, it will result in decrease of the hot inlet temperature of FEHE1. Then, the hot outlet temperature of FEHE1 slowly drops (Figure 6.4.l). Therefore, the cooler duty decreases significantly, since the cooler inlet temperature decreases (Figure 6.4.m). But, the furnace duty increases because the furnace inlet temperature decreases (Figure 6.4.j and k). On the other hand, when the temperature increases, it will result in increase of the hot inlet temperature of FEHE1. Then, the hot outlet temperature of FEHE1 slowly increases. Therefore, the cooler duty increases but the furnace duty decreases significantly, since the furnace inlet temperature increases.

As can be seen, the dynamic response of each loop is different. The separator temperature and the tray temperature in the product column are quite well controlled (Figure 6.4.c and f) but a deviation about 40C occurs in the tray temperature of the recycle column and it takes long times to return to its nominal value of 326.7°C (Figure 6.4.g). In addition, the reactor inlet temperature and the tray temperature in the stabilizer column have small oscillation (Figure 6.4.c and e).

6.1.1.4 Change in the Disturbance Load of Cold Stream from the Bottoms of Recycle Column

Figure 6.5 shows the dynamic responses of HDA process alternative 6 to a change in the disturbance load of cold stream from the bottoms of the recycle column, by changing its temperature from 349.8°C to 347.8°C at time equals 10 minutes, and the its temperature is increased from 347.8°C to 351.8°C at time equals 300 minutes, then its temperature is returned to its nominal value of 349.8°C at time equals 600 minutes.

In a particular case, both positive and negative disturbance loads of the cold stream that originating from the bottoms of the recycle column can be shifted to a furnace utility, since the hot outlet temperature of FEHE2 and FEHE3 have to be kept constant.

When the cold temperature decreases, then the hot outlet temperature of reboiler (R3) decreases. Consequently, the furnace duty increases (Figure 6.5.k), since the furnace inlet temperature decreases (Figure 6.5.j). On the other hand, when the cold temperature increases, then the hot outlet temperature of reboiler (R3) increases. Therefore, the furnace duty will be decreased, since the furnace inlet temperature increases. Besides, the separator temperature, the reactor inlet temperature and the tray temperature in the stabilizer and product column are slightly well controlled (Figure 6.5.c, d, e and f). The small deviation about 2°C occurs in the tray temperature of the recycle column and it takes more than 700 minutes to return to its nominal value of 326.7°C (Figure 6.5.g).

6.1.1.5 Change in the Disturbance Load of Hot Stream (Reactor Product)

Figure 6.6 shows the dynamic responses of HDA process to a change in the disturbance load of hot stream from reactor, by changing its temperature from 621.11°C to 616.11°C at time equals 10 minutes, and the its temperature is increased from 616.11°C to 626.11°C at time equals 200 minutes, then its temperature is returned to its nominal value of 621.11°C at time equals 400 minutes.

Again, the heat load disturbance of the hot stream can be shifted to the cold stream, since the hot outlet temperature of FEHE3 has to be kept constant. Both positive and negative disturbance loads of the hot stream are shifted to a furnace utility. When the hot temperature decreases, it will result in decrease of the furnace inlet temperature (Figure 6.6.j). Consequently, the furnace duty increases (Figure 6.6.k). On the other hand, when the positive disturbance load is originating from the hot stream (i.e. the hot inlet temperature increases), the furnace duty will be decreased, since the furnace inlet temperature increases. The

tray temperature in the recycle column has a deviation about 2°C and it takes long time to return to its nominal value of 326.7°C (Figure 6.6.g). Besides, the separator temperature and the reactor inlet temperature are quite well controlled (Figure 6.6.c and d).

6.1.1.6 Change in the Total Toluene Feed Flowrate

Figure 6.7 shows the dynamic responses of HDA process to a change in the total toluene feed flowrates from 168.4 kgmole/hr to 173.4 kgmole/hr at time equals 10 minutes, and the its feed flowrate is decreased from 173.4 kgmole/hr to 163.4 kgmole/hr at time equals 100 minutes, then its flowrates is returned to its nominal value of 168.4 kgmole/hr at time equals 200 minutes.

Energy integration causes the plant will be more difficult to control. Though HDA plant with energy integration (alternative 6) can recover more energy, but the control system in this complex energy integrated plant cannot handle large amount of disturbances.

To increase in total toluene flowrate raises the reaction rate, so the benzene product flowrate increases (Figure 6.7.p). On the other hand, the drop in total toluene feed flowrate reduces the reaction rate, so the benzene product flowrates drops but the benzene product quality is rarely affected by this change (Figure 6.7.q). The separator temperature is slightly well controlled (Figure 6.7.c), but the oscillations occur in the tray temperature of the stabilizer column and the reactor inlet temperature (Figure 6.7.b and d). For the tray temperature of the product column, it is quite well controlled when this disturbance occurs (Figure 6.7.e), but the tray temperature in the recycle column has a large change deviation of 40°C and it takes over 450 minutes to return to its nominal value of 326.7°C (Figure 6.7.f).

Table 6.1 The initial values of controlled and manipulated variables for HDA process with three auxiliary reboilers: Base Case

Controlled variable		Manipulated variable	
Process variable	Initial value	Process variable	Initial value
total toluene flowrate	168.4 kgmole/hr	fresh toluene feed flowrate	128.8 kgmole/hr
gas recycle stream pressure	605 psia	fresh hydrogen feed flowrate	220.4 kgmole/hr
methane in gas recycle	0.5877 mole-frac	purge flowrate	217.5 kgmole/hr
quenched temperature	621.1 °C	quench flowrate	48.49 kgmole/hr
reactor inlet temperature	621.1 °C	furnace duty	4708 kW
separator temperature	45 °C	cooler duty	1350 kW
hot outlet temperature of FEHE 2	340.5 °C	bypass flowrate of FEHE 2	291 kgmole/hr
hot outlet temperature of FEHE 3	450 °C	bypass flowrate of FEHE 3	200.5 kgmole/hr
separator liquid level	50 %-level	column C1 feed flowrate	171.4 kgmole/hr
column C1 pressure	150 psia	column C1 gas flowrate	8.495 kgmole/hr
column C1 tray-6 temperature	166.5 °C	auxiliary reboiler 1 (R1) duty	280.8 kW
column C1 base level	50 %-level	column C2 feed flowrate	162.9 kgmole/hr
column C1 reflux drum level	50 %-level	column C1 condenser duty	385.9 kW
column C1 boil-up flowrate	183 kgmole/hr	cold inlet flowrate of R1	183 kgmole/hr
column C2 pressure	30 psia	column C2 condenser duty	5013 kW
column C2 tray-12 temperature	129.7 °C	auxiliary reboiler 2 (R2) duty	391.7 kW
column C2 base level	50 %-level	column C3 feed flowrate	42.2 kgmole/hr
column C2 reflux drum level	50 %-level	column C2 product flowrate	120.7 kgmole/hr
column C2 boil-up flowrate	385 kgmole/hr	cold inlet flowrate of R2	385 kgmole/hr
column C3 pressure	76.32 psia	bypass flowrate of CR	25.76 kgmole/hr
avg C3-tray 1, 2, 3, and 4 temperature	326.7 °C	auxiliary reboiler 3 (R3) duty	16.07 kW
column C3 base level	50 %-level	column C3 bottom flowrate	2.643 kgmole/hr
column C3 reflux drum level	50 %-level	toluene recycle flowrate	39.55 kgmole/hr
column C3 boil-up flowrate	47.26 kgmole/hr	cold inlet flowrate of R3	47.26 kgmole/hr
column C3 reflux flowrate	9.94 kgmole/hr	column C3 reflux flowrate	9.94 kgmole/hr

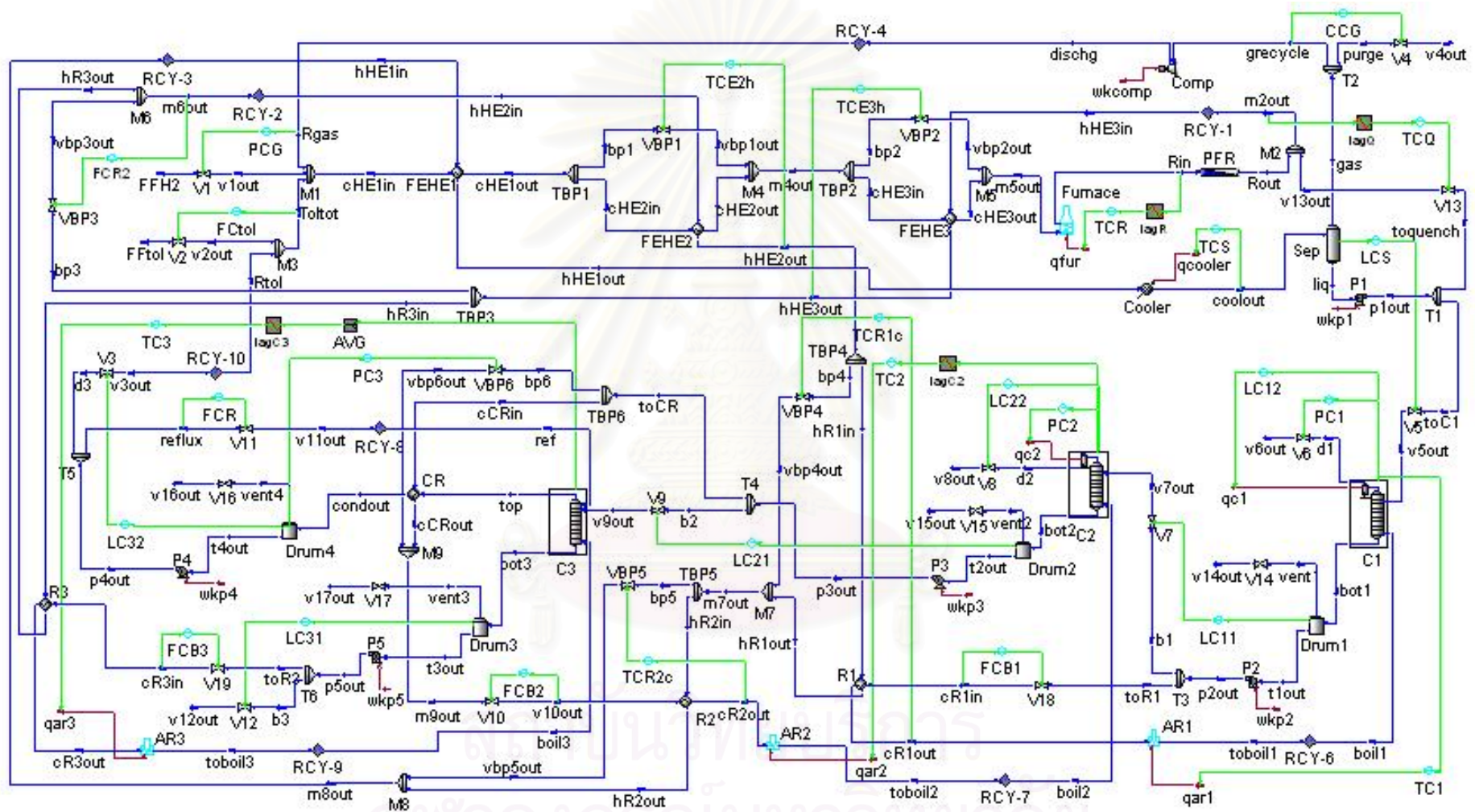

Figure 6.1: Base Case control structure of the HDA process with three auxiliary reboilers

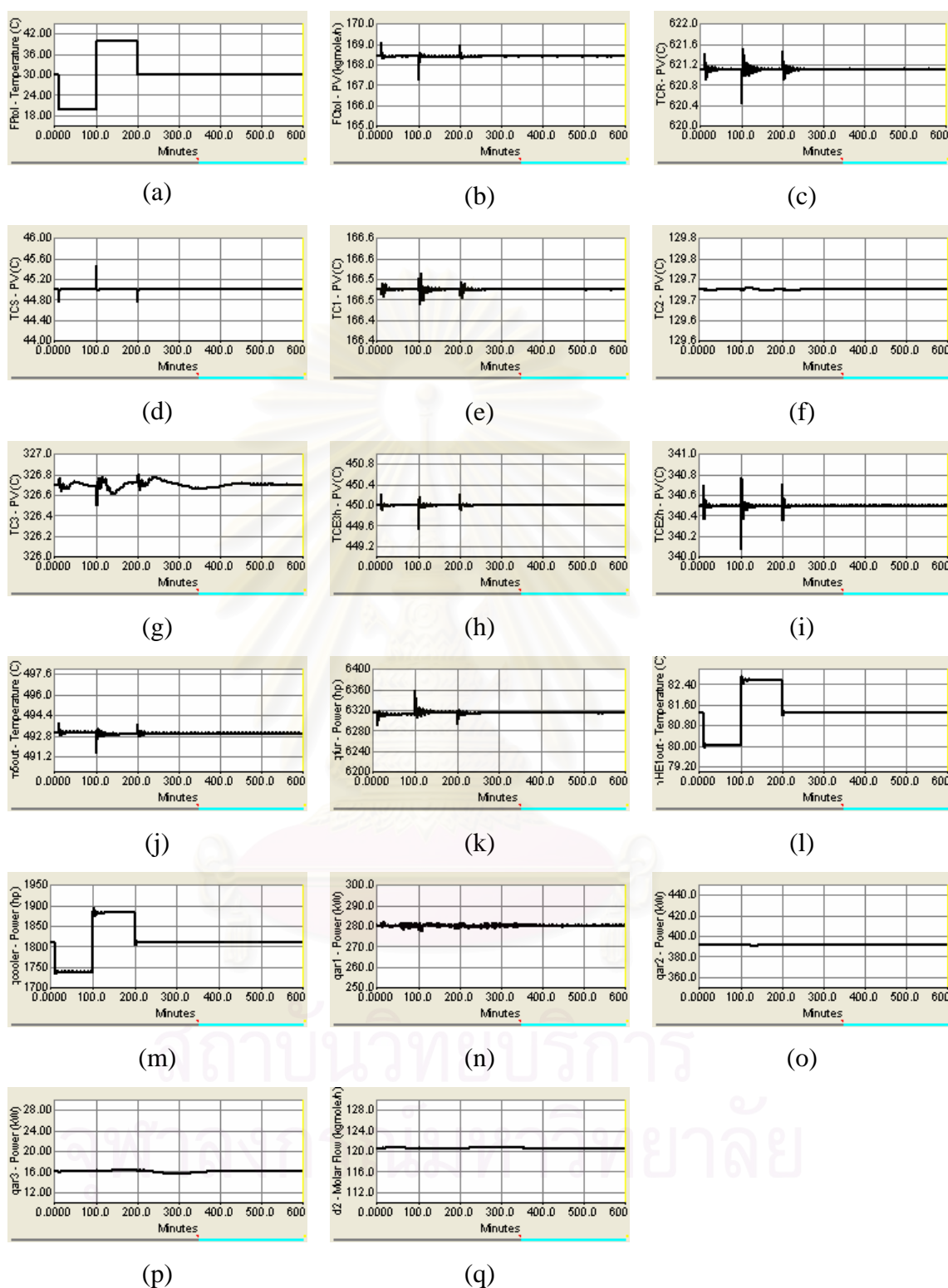

Figure 6.2: Dynamic responses of Base Case of the HDA process to a change in the disturbance load of cold stream (reactor feed stream)

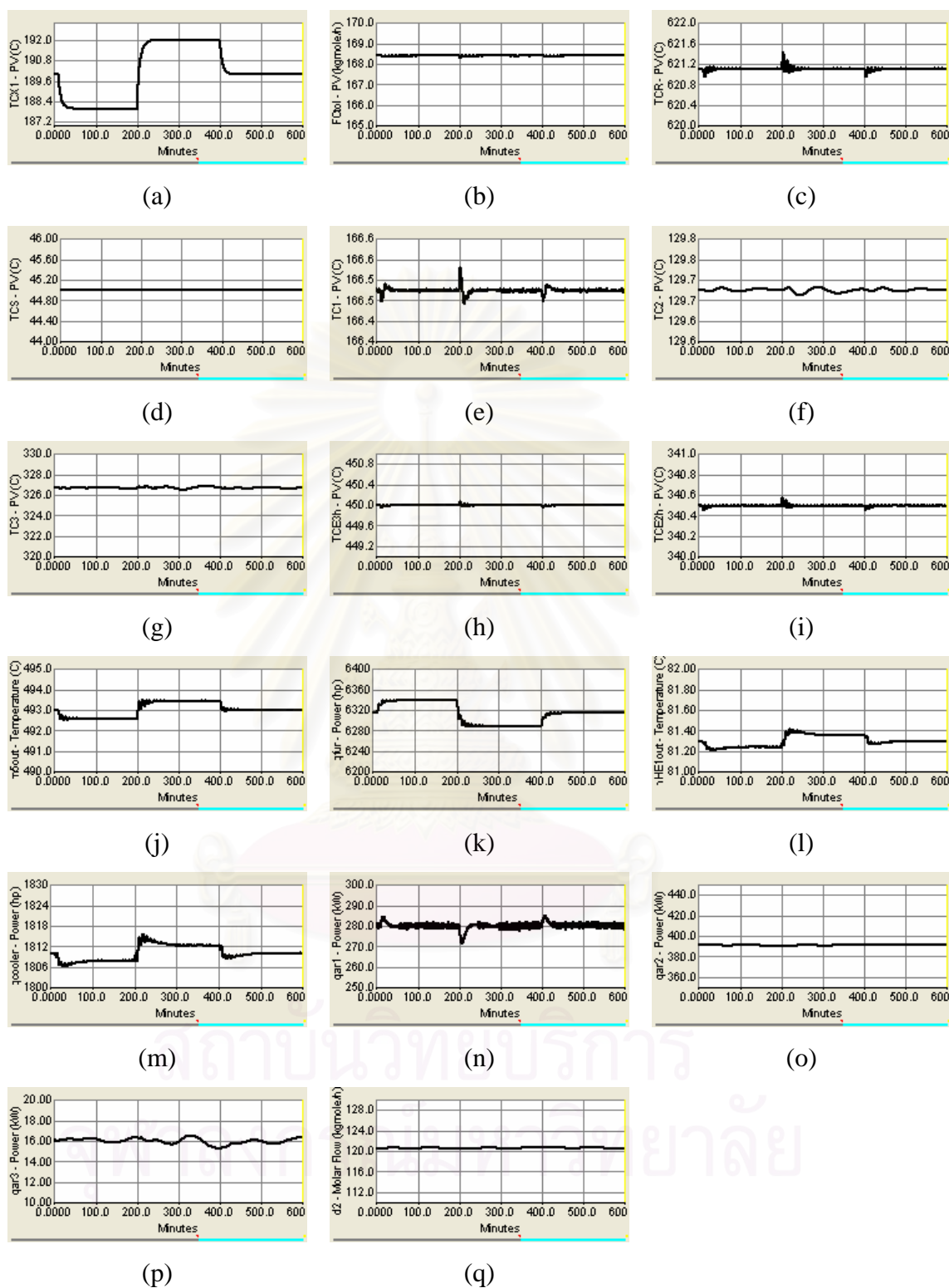

Figure 6.3: Dynamic responses of Base Case of the HDA process to a change in the disturbance load of cold stream from the bottom of stabilizer column

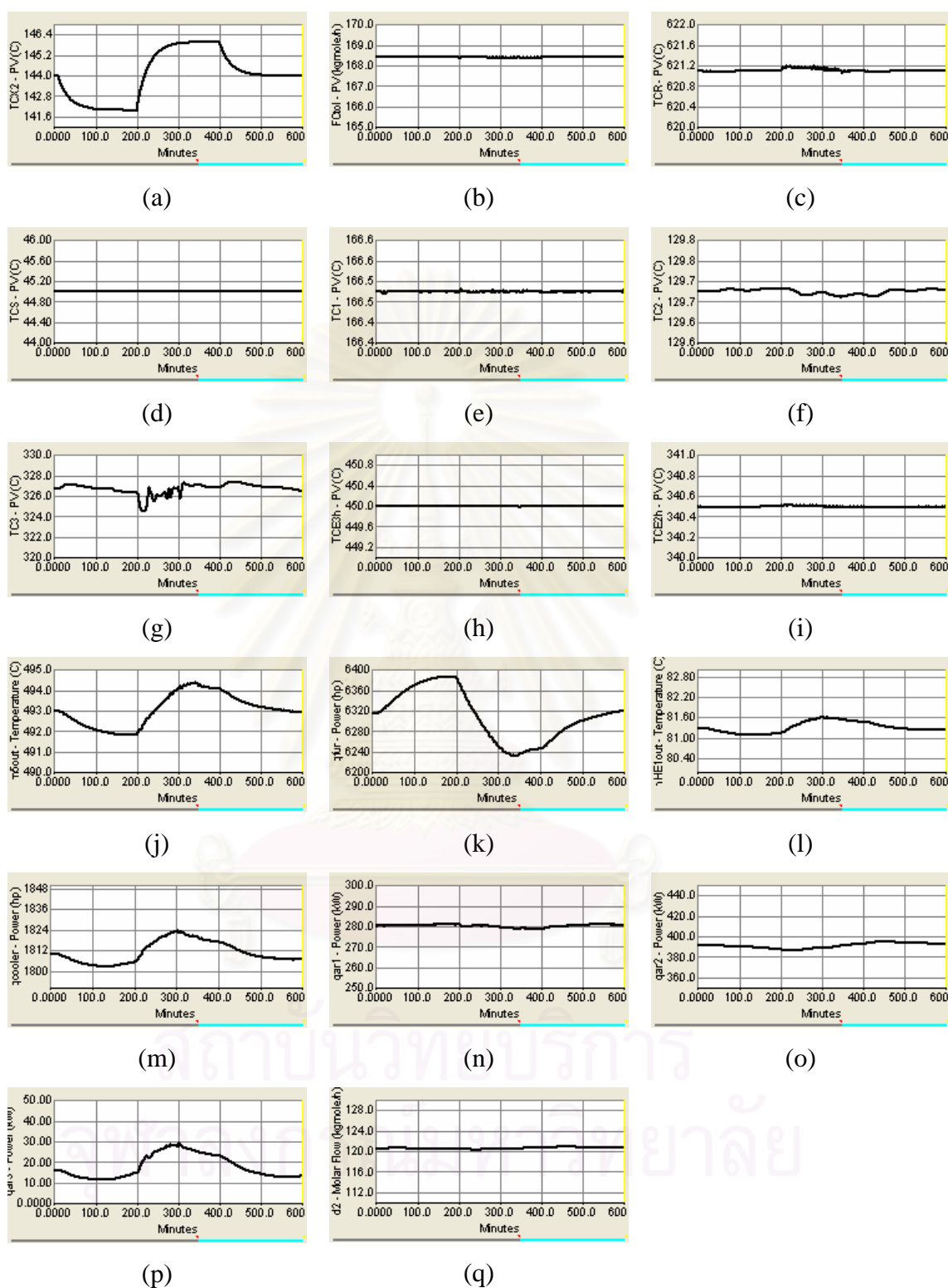

Figure 6.4: Dynamic responses of Base Case of the HDA process to a change in the disturbance load of cold stream from the bottom of product column

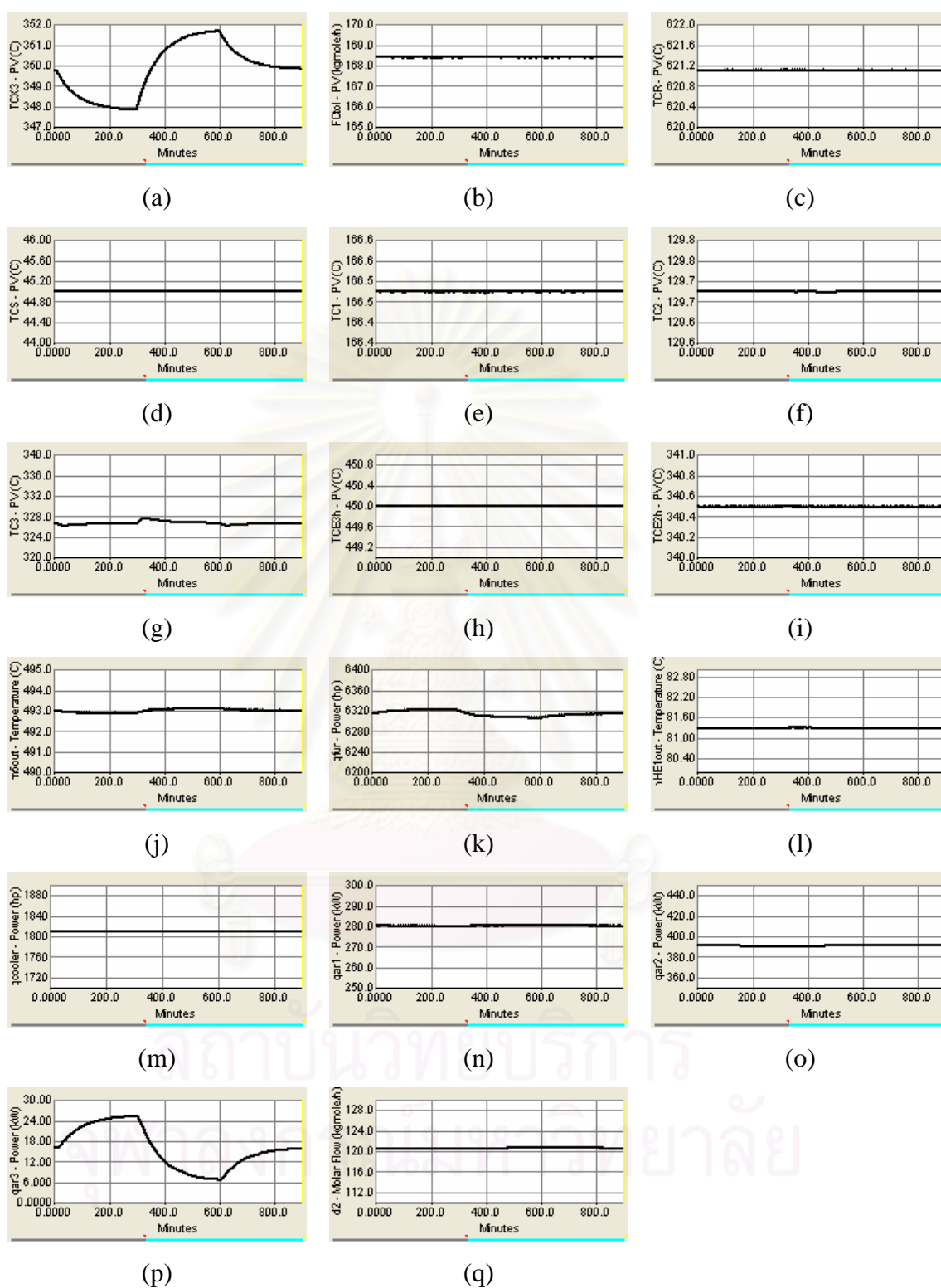

Figure 6.5: Dynamic responses of Base Case of the HDA process to a change in the disturbance load of cold stream from the bottom of recycle column

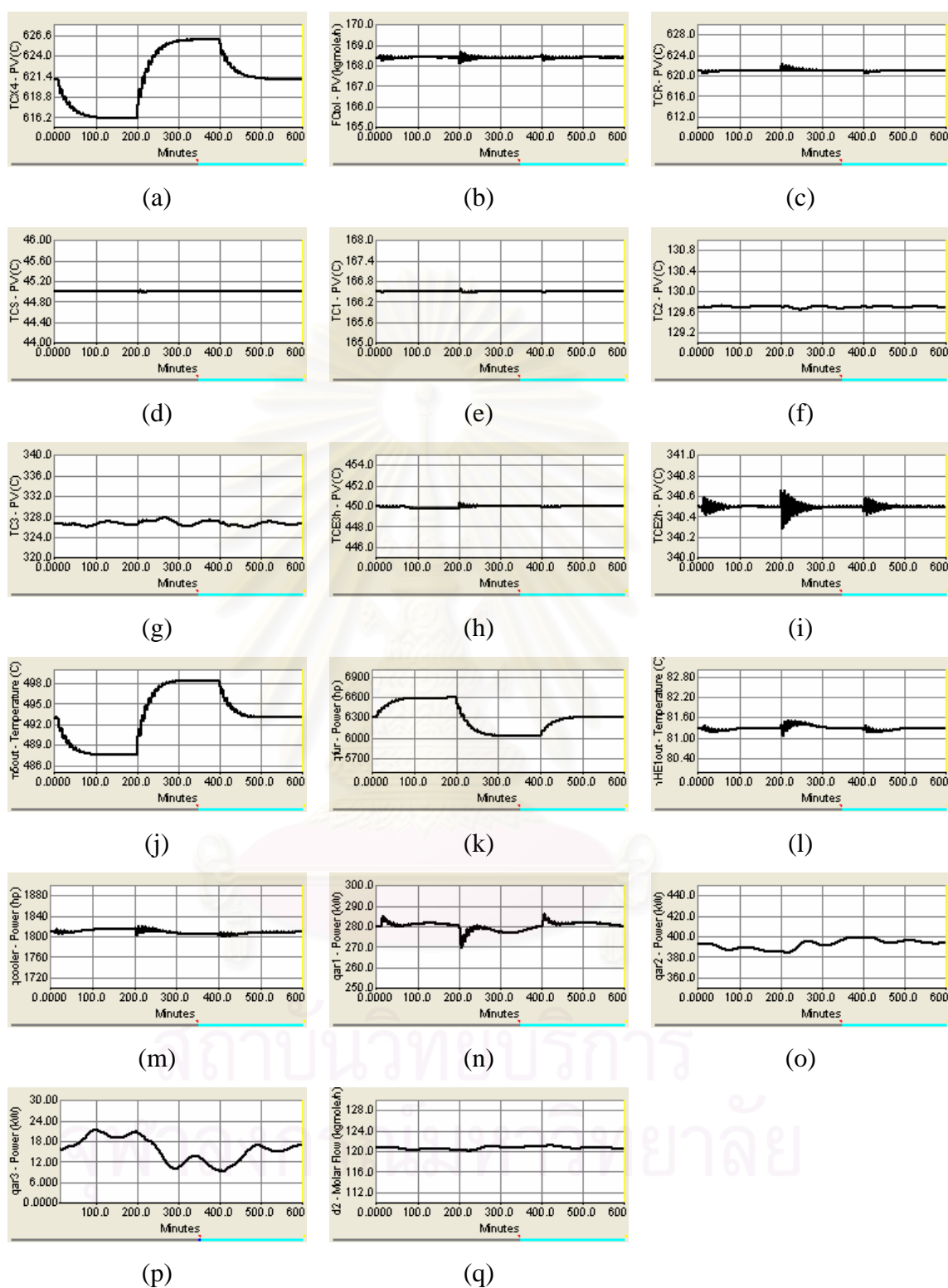

Figure 6.6: Dynamic responses of Base Case of the HDA process to a change in the disturbance load of hot stream (reactor product)

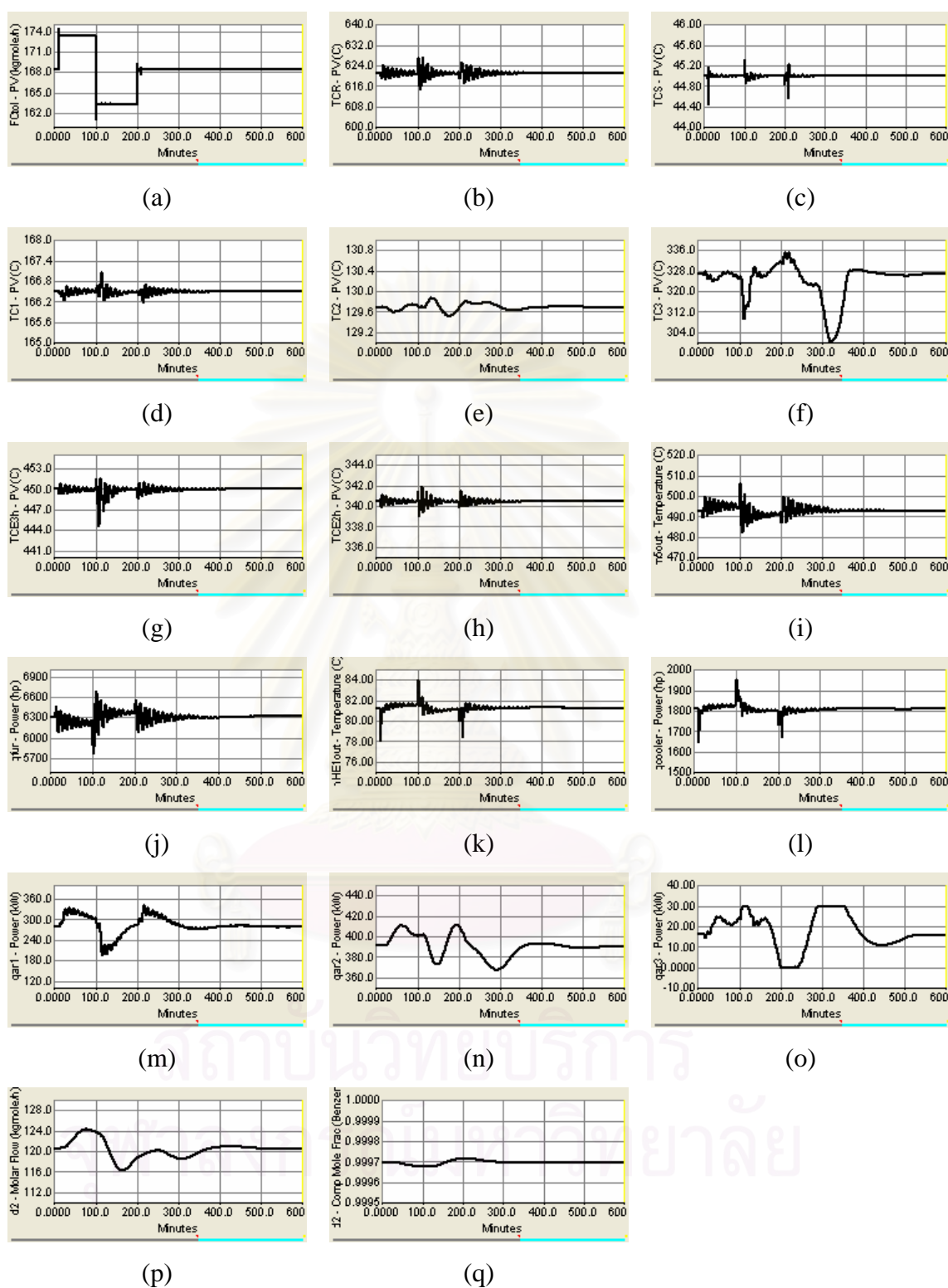

Figure 6.7: Dynamic responses of Base Case of the HDA process to a change in the total toluene feed flowrate

6.2 Design of plantwide Control for HDA Process with three Auxiliary Reboilers: Control Structure 1

The new plantwide control structure for energy-integrated HDA process with three auxiliary reboilers (CS1) is shown in Figure 6.8. Its major loops are the same as those used in the Base Case of the HDA process with three auxiliary reboilers, except for the tray temperature control in three distillation columns.

In this control structure for the HDA process with three auxiliary reboilers, we apply the Base Case by using a logical control concept. In this control structure both bypass valves of column heat exchanger and auxiliary reboiler duties are used to control the tray temperature of column. When bypass valve decrease to 5 percent opening but the tray temperature of the column cannot achieve its setpoint, the auxiliary reboiler duty will operate to control the tray temperature. Besides, there are two the tray temperature controllers in the stabilizer column. The initial values of all of the controlled and manipulated variables come from steady state simulation and listed in Table 6.2. The control structure and parameter controllers are shown in Table C.2. In this work, the type of controller for each control loop is different. P controllers are employed for the level loops, PID controllers are employed for the temperature loops and PI controllers are employed for the remaining loops.

6.2.1 Dynamic Simulation Results for HDA Process with three Auxiliary Reboilers: Control Structure 1

In order to illustrate the dynamic behavior of the control structure in HDA process alternative 6 with three auxiliary reboilers (CS1), several disturbance loads are made. The dynamic responses of the control system are shown in Figures 6.9 to 6.14. Results for individual disturbance load changes are as follows:

6.2.1.1 Change in the Disturbance Load of Cold Stream (Reactor Feed

Stream)

Figure 6.9 shows the dynamic responses to a change in the disturbance load of cold stream (reactor feed stream). This disturbance is made as follows: first the fresh toluene feed temperature is decreased from 30°C to 20°C at time equals 10 minutes, and the temperature is increased from 20°C to 40°C at time equals 100 minutes, then its temperature is returned to its nominal value of 30°C at time equals 200 minutes.

As can be seen, the dynamic responses of the CS1 with three auxiliary reboilers are similar to the previous control structure (Base Case). Particularly, the tray-6 temperature in the stabilizer column provides a well controlled (Figure 6.9.e) because there are two tray temperature controllers in the stabilizer column (One is the tray-3 temperature control and the other is tray-6 temperature control). The separator temperature and the tray temperature in the product column are well controlled (Figure 6.9.d and g) but the small oscillations happen in the reactor inlet temperature and the tray-3 temperature of the stabilizer and recycle column (Figure 6.9.c and f).

6.2.1.2 Change in the Disturbance Load of Cold Stream from the Bottoms of Stabilizer Column

Figure 6.10 shows the dynamic responses of HDA process alternative 6 (CS1) to a change in the disturbance load of cold stream which originating from the bottoms of the stabilizer column, by changing its temperature from 190°C to 188°C at time equals 10 minutes, and its temperature is increased from 188°C to 192°C at time equals 200 minutes, then its temperature is returned to its nominal value of 190°C at time equals 400 minutes.

As can be seen, the dynamic responses of the CS1 with three auxiliary reboilers are similar to the previous control structure. However, they are worse than that of the Base Case control structure. Since, the performance of the tray temperature controlling in distillation column by auxiliary reboiler duty is better than that by the bypass valve. Especially, the tray temperature control in the

recycle column provides a poor controlled (Figure 6.10.h). In addition, the small oscillations occur in the reactor inlet temperature and the tray temperature of the stabilizer column (Figure 6.10.c, e and f).

6.2.1.3 Change in the Disturbance Load of Cold Stream from the Bottoms of Product Column

Figure 6.11 shows the dynamic responses of HDA process to a change in the disturbance load of cold stream from the bottoms of the product column, by changing its temperature from 144°C to 142°C at time equals 10 minutes, and the its temperature is increased from 142°C to 146°C at time equals 200 minutes, then its temperature is returned to its nominal value of 144°C at time equals 400 minutes.

The dynamic responses of the CS1 with three auxiliary reboilers are similar to the Base Case with three auxiliary reboilers when the change in the disturbance load of the cold stream from the bottoms of the product column occurs. However, they are worse than that of one because the performance of the tray temperature controlling in distillation column by auxiliary reboiler duty is better than that by the bypass valve (i.e. the tray temperature in the recycle column).

However, the other dynamic responses of this control structure are not different from the Base Case. The separator temperature and the tray temperature in the product column are slightly well controlled (Figure 6.11.d and g) but small oscillations happen in the reactor inlet temperature and the tray temperature of the stabilizer column (Figure 6.11.c, e and f). But, the tray temperature in the recycle column has a large deviation about 25°C and it takes more than 500 minutes to return to its nominal value (Figure 6.11.h).

6.2.1.4 Change in the Disturbance Load of Cold Stream from the Bottoms of Recycle Column

Figure 6.12 shows the dynamic responses of HDA process alternative 6 (CS1) to a change in the disturbance load of cold stream from the bottoms of

the recycle column, by changing its temperature from 349.8°C to 347.8°C at time equals 10 minutes, and the its temperature is increased from 347.8°C to 351.8°C at time equals 300 minutes, then its temperature is returned to its nominal value of 349.8°C at time equals 600 minutes.

Again, the dynamic responses of this control structure are worse than that of the Base Case control structure when this disturbance occurs. Particularly, the tray temperature in the recycle column provides a poor controlled (Figure 6.12.h), since the performance of the tray temperature controlling in distillation column by auxiliary reboiler duty is better than that by the bypass valve. However, the other dynamic responses of this control structure are similar to the Base Case control structure (i.e. the separator temperature, the reactor inlet temperature and the tray temperature in the stabilizer and product column are quite well controlled (Figure 6.12.c, d, e and f)). But, the tray temperature in the recycle has a large deviation about 10°C and it takes long time to return to its nominal value.

6.2.1.5 Change in the Disturbance Load of Hot Stream (Reactor Product)

Figure 6.13 shows the dynamic responses of HDA process to a change in the disturbance load of hot stream from reactor, by changing its temperature from 621.11°C to 616.11°C at time equals 10 minutes, and the its temperature is increased from 616.11°C to 626.11°C at time equals 200 minutes, then its temperature is returned to its nominal value of 621.11°C at time equals 400 minutes.

The dynamic responses of this control structure are worse than that of the Base Case control structure. Particularly, the tray temperature control in the recycle column provides a poor performance (Figure 6.13.h) because the performance of the tray temperature controlling in distillation column by auxiliary reboiler duty is better than that by the bypass valve. The separator temperature, the reactor inlet temperature and the tray temperature in the stabilizer and product column are slightly well controlled (Figure 6.13.c, d, e and f).

6.2.1.6 Change in the Total Toluene Feed Flow rate

Figure 6.14 shows the dynamic responses of HDA process to a change in the total toluene feed flowrates from 168.4 kgmole/hr to 173.4 kgmole/hr at time equals 10 minutes, and the its feed flowrate is decreased from 173.4 kgmole/hr to 163.4 kgmole/hr at time equals 100 minutes, then its flowrates is returned to its nominal value of 168.4 kgmole/hr at time equals 200 minutes.

As can be seen, the dynamic responses of the CS1 with three auxiliary reboilers are worse than that of the Base Case control structure. Again, the separator temperature is well controlled (Figure 6.14.c) but the oscillations occur in the tray temperature in the stabilizer column and the reactor inlet temperature as the same Base Case structure (Figure 6.14.b, d and e).

The tray temperature in the product column is quite well controlled (Figure 6.14.f). For the tray temperature in the recycle has a large deviation about 40°C and it takes long time to return to its nominal value of 326.7°C (Figure 6.14.g).

6.3 Design of plantwide Control for HDA Process with three Auxiliary Reboilers: Control Structure 2

The new plantwide control structure for energy-integrated HDA process with three auxiliary reboilers (CS2) is shown in Figure 6.15. Its major loops are the same as those used in Base Case of the HDA process with three auxiliary reboilers, except for the tray temperature control in three distillation columns except, the feed flowrate control in the recycle column and the level control of Drum 2 in the product column.

The new second control structure for the HDA process with three auxiliary reboilers, we apply the CS1 by changing the manipulated variable of the column C2 base level control from the feed flowrate of recycle column to the cold inlet flowrate of R2 and the feed flowrate of recycle column is flow-controlled for to reduce the

Table 6.2 The initial values of controlled and manipulated variables for HDA process with three auxiliary reboilers: Control Structure 1

Controlled variable		Manipulated variable	
Process variable	Initial value	Process variable	Initial value
total toluene flowrate	168.4 kgmole/hr	fresh toluene feed flowrate	128.8 kgmole/hr
gas recycle stream pressure	605 psia	fresh hydrogen feed flowrate	220.4 kgmole/hr
methane in gas recycle	0.5877 mole-frac	purge flowrate	217.5 kgmole/hr
quenched temperature	621.1 °C	quench flowrate	48.49 kgmole/hr
reactor inlet temperature	621.1 °C	furnace duty	4708 kW
separator temperature	45 °C	cooler duty	1350 kW
hot outlet temperature of FEHE 2	340.5 °C	bypass flowrate of FEHE 2	291 kgmole/hr
hot outlet temperature of FEHE 3	450 °C	bypass flowrate of FEHE 3	200.5 kgmole/hr
separator liquid level	50 %-level	column C1 feed flowrate	171.4 kgmole/hr
column C1 pressure	150 psia	column C1 gas flowrate	8.495 kgmole/hr
column C1 tray-3 temperature	177.3 °C	bypass flowrate of R1	593.4 kgmole/hr
		auxiliary reboiler 1 (R1) duty	280.6 kW
column C1 tray-6 temperature	166.5 °C	column C1 reflux flowrate	32.68 kgmole/hr
column C1 base level	50 %-level	column C2 feed flowrate	162.9 kgmole/hr
column C1 reflux drum level	50 %-level	column C1 condenser duty	385.9 kW
column C1 boil-up flowrate	183 kgmole/hr	cold inlet flowrate of R1	183 kgmole/hr
column C2 pressure	30 psia	column C2 condenser duty	5013 kW
column C2 tray-12 temperature	129.7 °C	bypass flowrate of R2	156.1 kgmole/hr
		auxiliary reboiler 2 (R2) duty	392.1 kW
column C2 base level	50 %-level	column C3 feed flowrate	42.2 kgmole/hr
column C2 reflux drum level	50 %-level	column C2 product flowrate	120.7 kgmole/hr
column C2 boil-up flowrate	385 kgmole/hr	cold inlet flowrate of R2	385 kgmole/hr
column C3 pressure	76.32 psia	bypass flowrate of CR	25.76 kgmole/hr
avg C3-tray 1, 2, 3, and 4 temperature	326.7 °C	bypass flowrate of R3	120.2 kgmole/hr
		auxiliary reboiler 3 (R3) duty	15.75 kW
column C3 base level	50 %-level	column C3 bottom flowrate	2.643 kgmole/hr
column C3 reflux drum level	50 %-level	toluene recycle flowrate	39.55 kgmole/hr
column C3 boil-up flowrate	47.26 kgmole/hr	cold inlet flowrate of R3	47.26 kgmole/hr
column C3 reflux flowrate	9.94 kgmole/hr	column C3 reflux flowrate	9.94 kgmole/hr

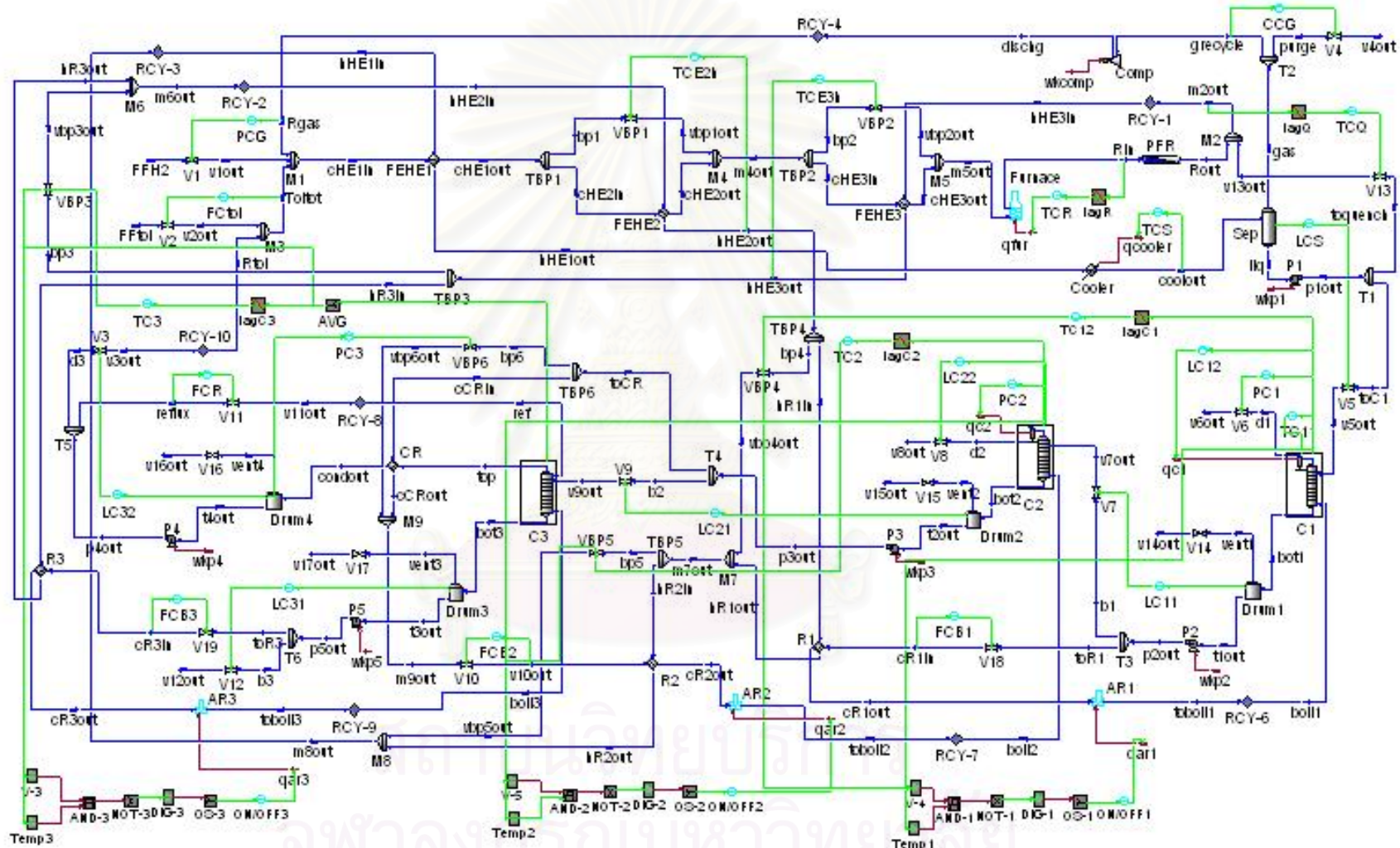

Figure 6.8: Control structures 1 of the HDA process with three auxiliary reboilers

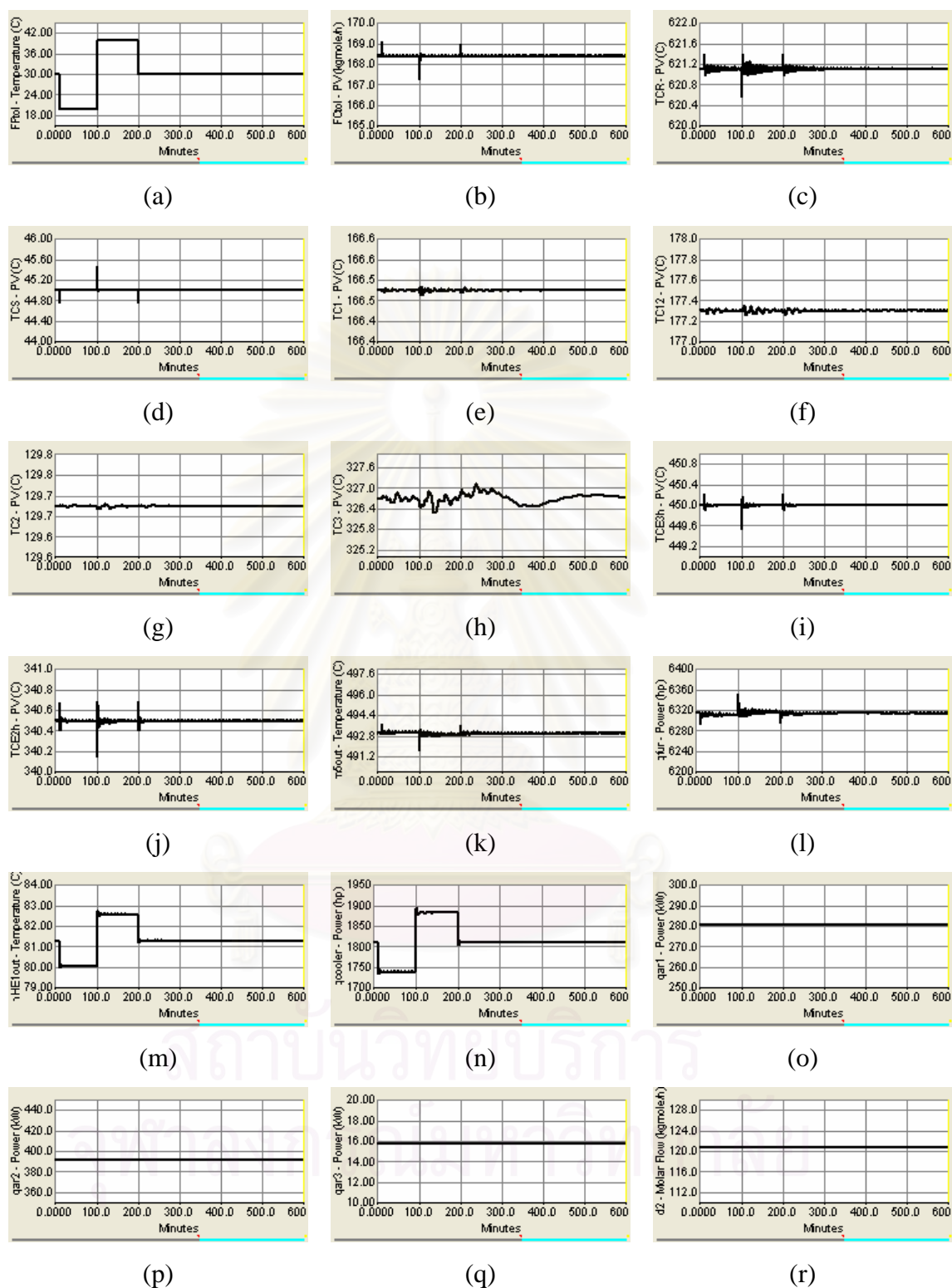

Figure 6.9: Dynamic responses of CS1 of the HDA process to a change in the disturbance load of cold stream (reactor feed stream)

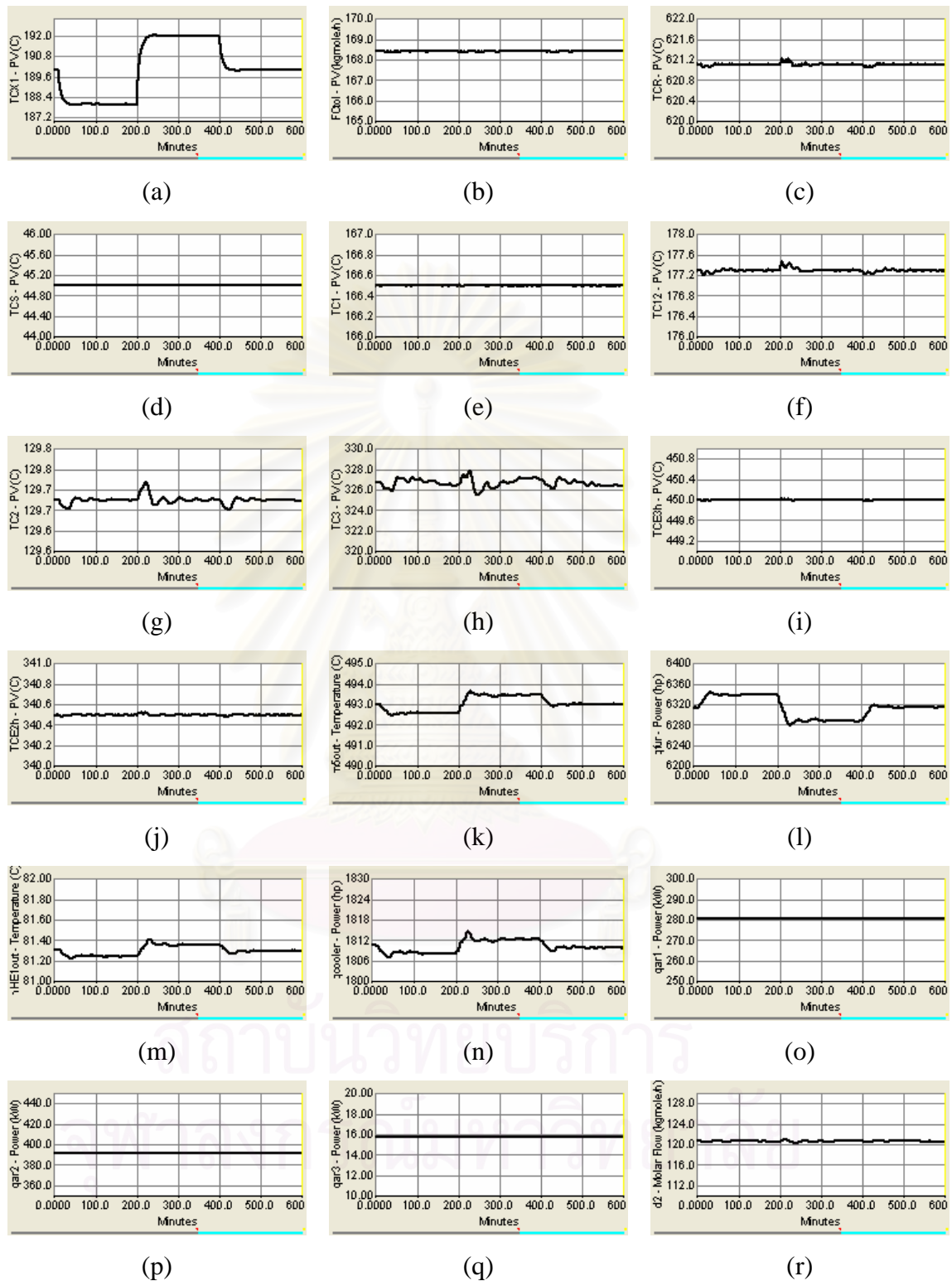

Figure 6.10: Dynamic responses of CS1 of the HDA process to a change in the disturbance load of cold stream from the bottom of stabilizer column

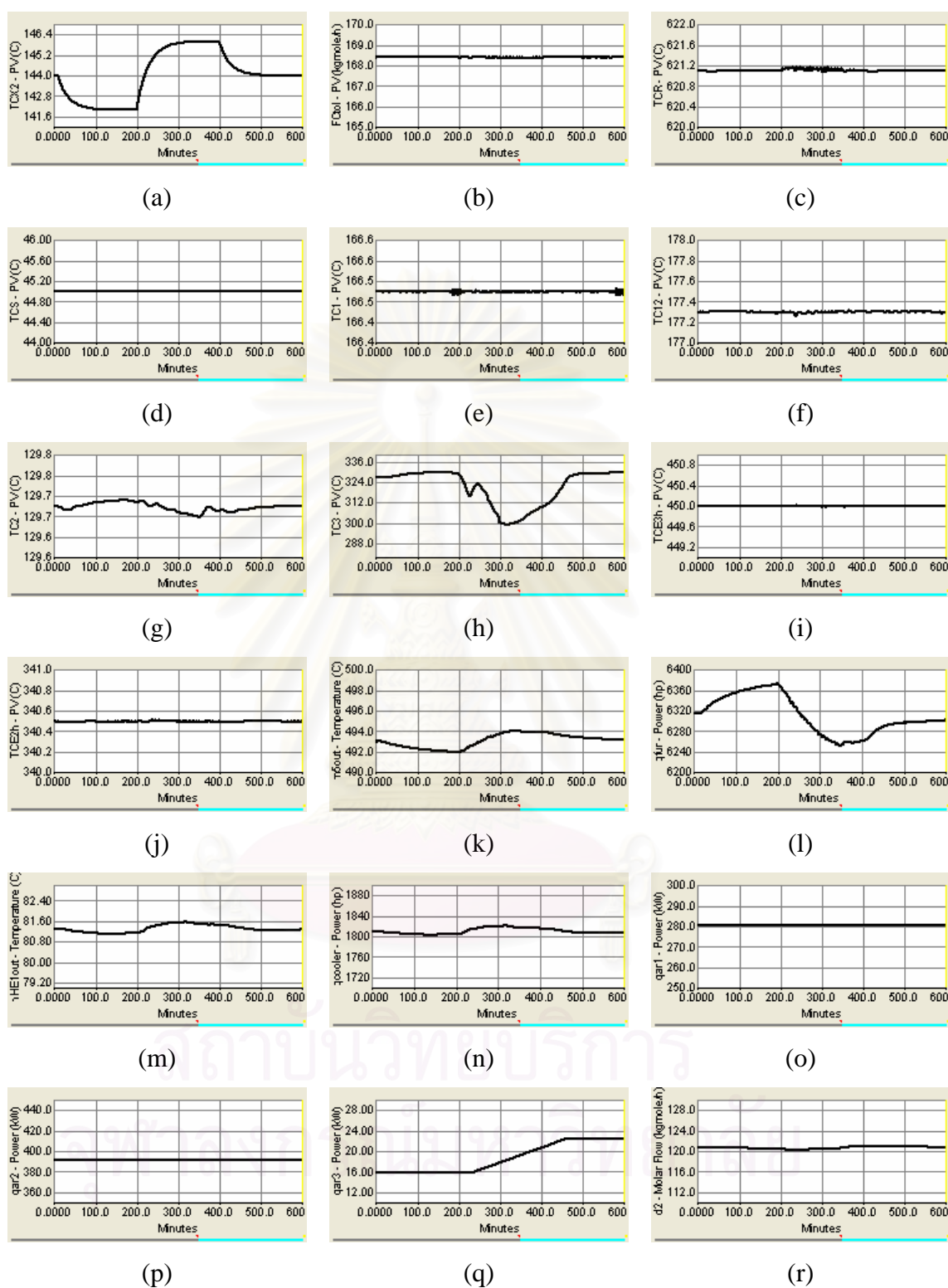

Figure 6.11: Dynamic responses of CS1 of the HDA process to a change in the disturbance load of cold stream from the bottom of product column

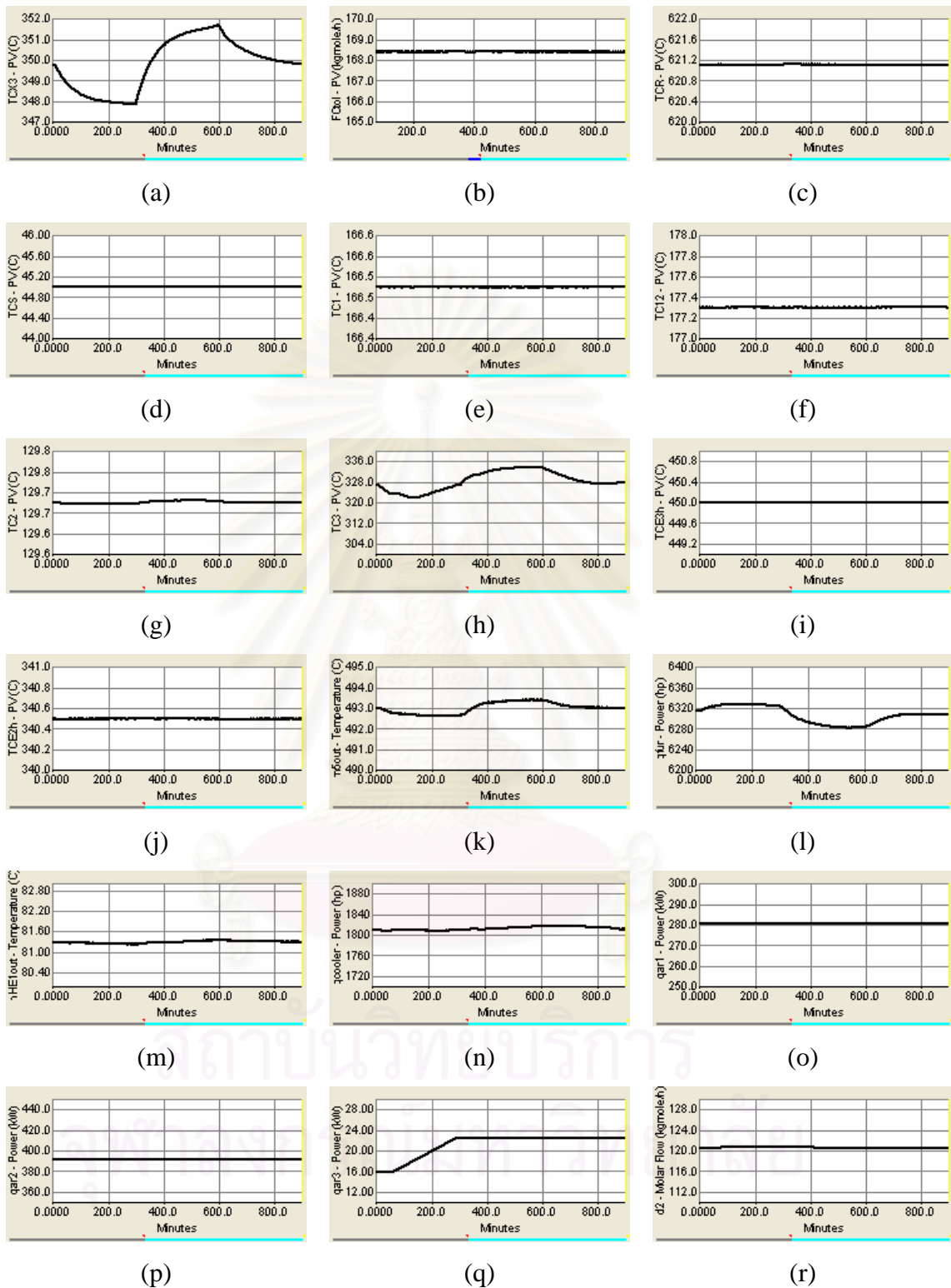

Figure 6.12: Dynamic responses of CS1 of the HDA process to a change in the disturbance load of cold stream from the bottom of recycle column

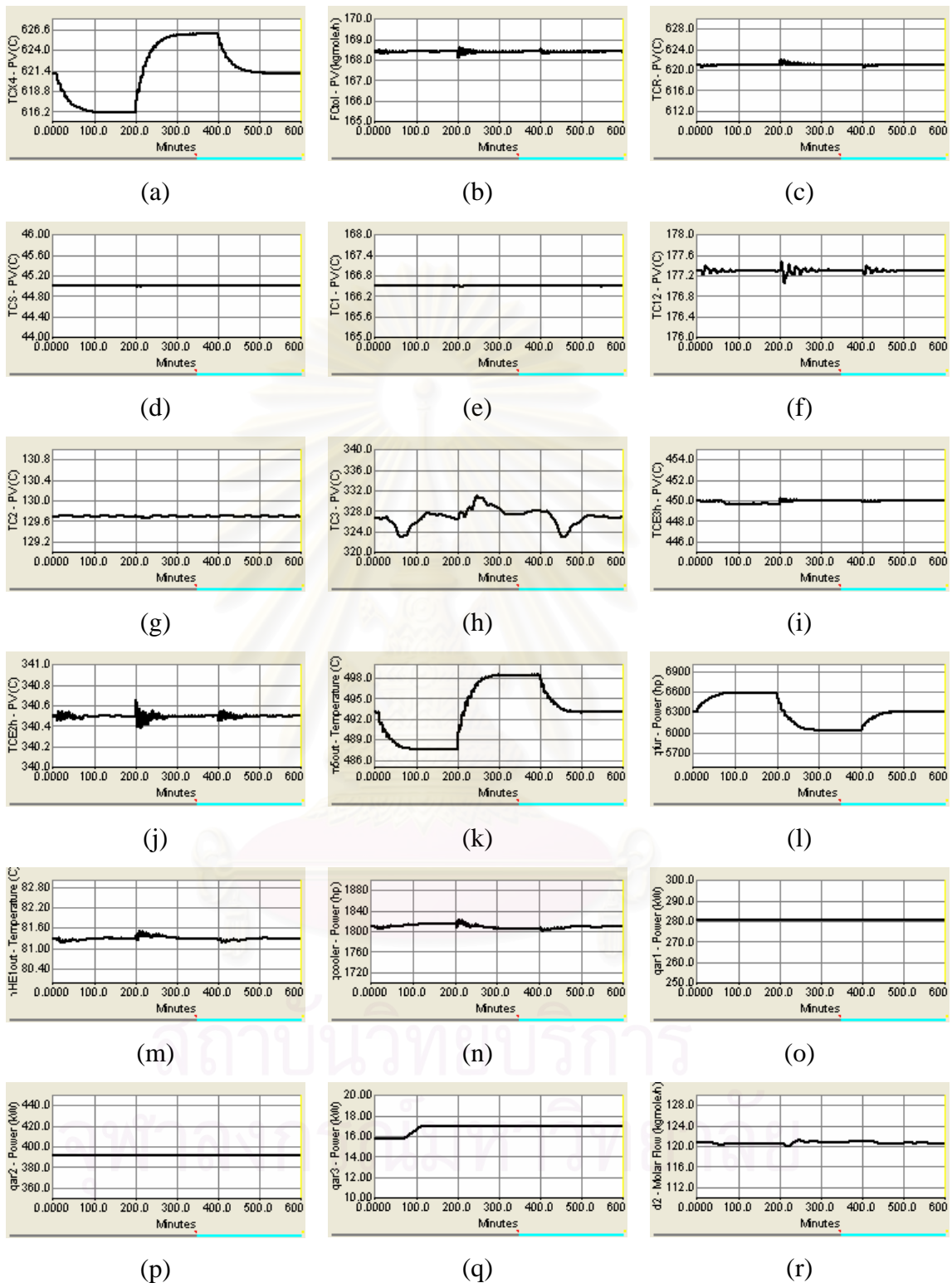

Figure 6.13: Dynamic responses of CS1 of the HDA process to a change in the disturbance load of hot stream (reactor product)

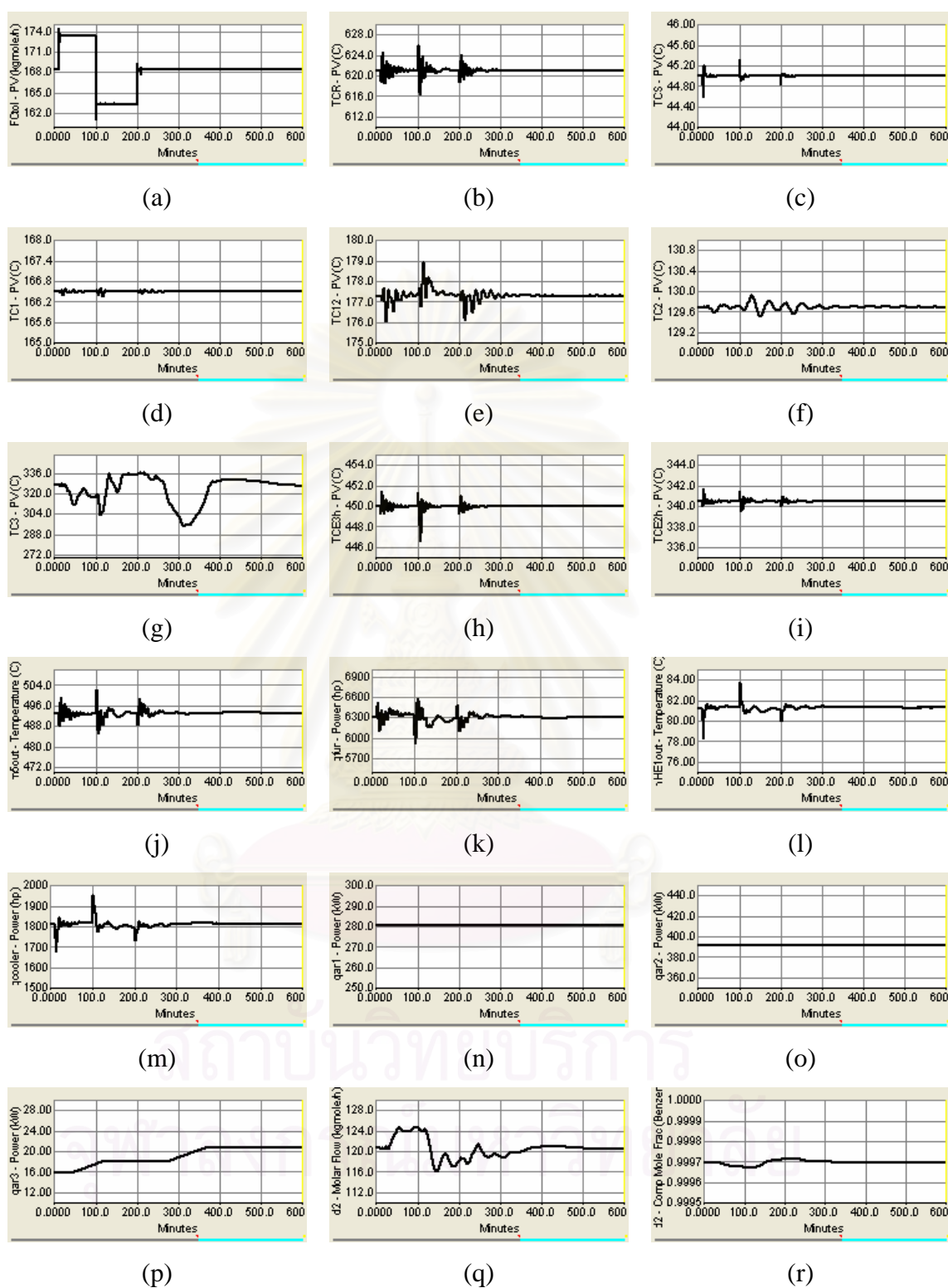

Figure 6.14: Dynamic responses of CS1 of the HDA process to a change in the total toluene feed flowrate

material and flow fluctuation before propagate to the recycle column when the disturbance occurs. The initial values of all of the controlled and manipulated variables come from steady state simulation and listed in Table 6.3. The control structure and controller parameters are shown in Table C.3. In this work, the type of controller for each control loop is different. P controllers are employed for the level loops, PID controllers are employed for the temperature loops and PI controllers are employed for the remaining loops.

6.3.1 Dynamic Simulation Results for HDA Process with three Auxiliary Reboilers: Control Structure 2

In order to illustrate the dynamic behavior of the control structure in HDA process Alternative 6 with three auxiliary reboilers (CS2), several disturbance loads are made. The dynamic responses of the control system are shown in Figures 6.16 to 6.21. Results for individual disturbance load changes are as follows:

6.3.1.1 Change in the Disturbance Load of Cold Stream (Reactor Feed Stream)

Figure 6.16 shows the dynamic responses to a change in the disturbance load of cold stream (reactor feed stream). This disturbance is made as follows: first the fresh toluene feed temperature is decreased from 30°C to 20°C at time equals 10 minutes, and the temperature is increased from 20°C to 40°C at time equals 100 minutes, then its temperature is returned to its nominal value of 30°C at time equals 200 minutes.

The dynamic responses of this control structure are the best of all control structures with three auxiliary reboilers when the change in the disturbance load of the cold stream occurs. Because, the feed flowrate of the recycle column is flow-controlled, so this control structure can reject the disturbance load before it enters to the recycle column. As a result, the performance of the tray temperature in the recycle column in this control structure is better than that of Base Case. In addition, the separator temperature and the tray temperature in the product

column are well controlled (Figure 6.16.d and g). But the small oscillations occur in the reactor inlet temperature and the tray temperature in the stabilizer column (Figure 6.16.c, e and f).

6.3.1.2 Change in the Disturbance Load of Cold Stream from the Bottoms of Stabilizer Column

Figure 6.17 shows the dynamic responses of HDA process alternative 6 (CS2) to a change in the disturbance load of cold stream which originating from the bottoms of the stabilizer column, by changing its temperature from 190°C to 188°C at time equals 10 minutes, and its temperature is increased from 188°C to 192°C at time equals 200 minutes, then its temperature is returned to its nominal value of 190°C at time equals 400 minutes.

The dynamic responses of this control structure are the best of all control structures with three auxiliary reboilers when the change in the disturbance load of the cold stream from the bottoms of the stabilizer column occurs because the feed flowrate of the recycle column is flow-controlled. As a result, the effect of this disturbance is reduced before it enters to the recycle column. Particularly, the tray temperature in the recycle column provides a well controlled (Figure 6.17.h). However, other dynamic responses are similar to previous control structure when this disturbance occurs (i.e. the separator temperature, the reactor inlet temperature and the tray temperature in the stabilizer and product column (Figure 6.17.c, d, e, f and g)).

6.3.1.3 Change in the Disturbance Load of Cold Stream from the Bottoms of Product Column

Figure 6.18 shows the dynamic responses of HDA process to a change in the disturbance load of cold stream from the bottoms of the product column, by changing its temperature from 144°C to 142°C at time equals 10 minutes, and the its temperature is increased from 142°C to 146°C at time equals 200 minutes, then its temperature is returned to its nominal value of 144°C at time equals 400 minutes.

The dynamic responses of the CS2 with three auxiliary reboilers are better than that of the Base Case when this change occurs because the feed flowrate of the recycle column is flow-controlled. As a result, the effect of this change is reduced before it enters to the recycle column. Thus, the performance of the tray temperature control in the recycle column of this control structure is better than the CS1. However, the overall performance of the CS2 is worse than the Base Case control structure when this disturbance happens.

Again, the separator temperature and the tray temperature in the product column are slightly well controlled (Figure 6.18.d and g) but small oscillations happen in the reactor inlet temperature and the tray temperature of the stabilizer column (Figure 6.18.c, e and f). Besides, the tray temperature in the recycle column has a deviation about 24°C and it takes more than 500 minutes to return to its nominal value of 326.7°C (Figure 6.18.h).

6.3.1.4 Change in the Disturbance Load of Cold Stream from the Bottoms of Recycle Column

Figure 6.19 shows the dynamic responses of HDA process alternative 6 (CS1) to a change in the disturbance load of cold stream from the bottoms of the recycle column, by changing its temperature from 349.8°C to 347.8°C at time equals 10 minutes, and the its temperature is increased from 347.8°C to 351.8°C at time equals 300 minutes, then its temperature is returned to its nominal value of 349.8°C at time equals 600 minutes.

There are three different of this control structure over to the base case. First, the feed flow rate of the recycle column is flow-controlled. Second, the manipulated variable of the base level control in the product column is changed from the feed flow rate of recycle column to cold inlet flowrate of R2 condenser. Third, a logical control concept is introduced to control the tray temperature in three distillation columns. Consequently, this control structure provides slightly poor tray temperature control due to the performance of the tray temperature controlling in distillation column by auxiliary reboiler duty is better than that by

the bypass valve. However, the overall performance of this control structure is better than that of Base Case with three auxiliary reboilers since the change is reduced before to enter to the recycle column.

6.3.1.5 Change in the Disturbance Load of Hot Stream (Reactor Product)

Figure 6.20 shows the dynamic responses of HDA process to a change in the disturbance load of hot stream from reactor, by changing its temperature from 621.11°C to 616.11°C at time equals 10 minutes, and the its temperature is increased from 616.11°C to 626.11°C at time equals 200 minutes, then its temperature is returned to its nominal value of 621.11°C at time equals 400 minutes.

As the change in the disturbance load of the hot stream occurs, the disturbance rejection of this new manipulated variable is the best in all control structures, since the feed flow rate of the recycle column is controlled. So the change in the disturbance load of the hot stream does not propagate to the recycle column. Thus, the tray temperature in the recycle column provides a quite well controlled (Figure 6.20.h). However, the other dynamic responses of this control structure are similar to the previous control structure (i.e. the separator temperature, the reactor inlet temperature and the tray temperature in the stabilizer and product column (Figure 6.20.c, d, e, f and g)).

6.3.1.6 Change in the Total Toluene Feed Flowrate

Figure 6.21 shows the dynamic responses of HDA process to a change in the total toluene feed flowrates from 168.4 kgmole/hr to 173.4 kgmole/hr at time equals 10 minutes, and the its feed flowrate is decreased from 173.4 kgmole/hr to 163.4 kgmole/hr at time equals 100 minutes, then its flowrates is returned to its nominal value of 168.4 kgmole/hr at time equals 200 minutes.

This is the best control structure for to handle a change in the total toluene feed flowrate. As can be seen that the separator temperature is quite well controlled (Figure 6.21.c), the oscillations occur in the tray temperature of the sta-

bilizer column and the reactor inlet temperature as the same Base Case control structure (Figure 6.21.b, d and e). Since, the feed flowrate of recycle column is flow-controlled, so the tray temperature control of recycle column in this control structure provides a well controlled. A deviation about 12°C happens in the tray temperature of the recycle column (Figure 6.21.g). Besides, the product benzene quality is quite well controlled during the change in the total toluene feed flowrate occurs (Figure 6.21.r).

6.4 Design of plantwide Control for HDA Process with three Auxiliary Reboilers: Control Structure 3

The new plantwide control structure for energy-integrated HDA process with three auxiliary reboilers (CS3) is shown in Figure 6.22. Its major loops are the same as those used in Base Case of the HDA process with three auxiliary reboilers, except for the tray temperature control in three distillation columns except, the feed flowrate control in the recycle column, the level control of Drum 2 in the product column, the column C1 pressure control, the column C1 reflux drum level control and the tray-6 temperature control in column C1.

The last (third) control structure for the HDA process with three auxiliary reboilers, we apply the CS2 by changing the manipulated variable of the column C1 pressure control, the column C1 reflux drum level control and the tray-6 temperature control in column C1 from the column C1 gas flowrate, the column C1 condenser duty and the column C1 reflux rate to the column C1 condenser duty, the column C1 reflux rate and the column C1 gas flowrate, respectively. The initial values of all of the controlled and manipulated variables come from steady state simulation and listed in Table 6.4. The control structure and controller parameters are shown in Table C.4. In this work, the type of controller for each control loop is different. P controllers are employed for the level loops, PID controllers are employed for the temperature loops and PI controllers are employed

Table 6.3 The initial values of controlled and manipulated variables for HDA process with three auxiliary reboilers: Control Structure 2

Controlled variable		Manipulated variable	
Process variable	Initial value	Process variable	Initial value
total toluene flowrate	168.4 kgmole/hr	fresh toluene feed flowrate	128.8 kgmole/hr
gas recycle stream pressure	605 psia	fresh hydrogen feed flowrate	220.4 kgmole/hr
methane in gas recycle	0.5877 mole-frac	purge flowrate	217.5 kgmole/hr
quenched temperature	621.1 °C	quench flowrate	48.49 kgmole/hr
reactor inlet temperature	621.1 °C	furnace duty	4708 kW
separator temperature	45 °C	cooler duty	1350 kW
hot outlet temperature of FEHE 2	340.5 °C	bypass flowrate of FEHE 2	291 kgmole/hr
hot outlet temperature of FEHE 3	450 °C	bypass flowrate of FEHE 3	200.5 kgmole/hr
separator liquid level	50 %-level	column C1 feed flowrate	171.4 kgmole/hr
column C1 pressure	150 psia	column C1 gas flowrate	8.495 kgmole/hr
column C1 tray-3 temperature	177.3 °C	bypass flowrate of R1	593.4 kgmole/hr
		auxiliary reboiler 1 (R1) duty	280.6 kW
column C1 tray-6 temperature	166.5 °C	column C1 reflux flowrate	32.68 kgmole/hr
column C1 base level	50 %-level	column C2 feed flowrate	162.9 kgmole/hr
column C1 reflux drum level	50 %-level	column C1 condenser duty	385.9 kW
column C1 boil-up flowrate	183 kgmole/hr	cold inlet flowrate of R1	183 kgmole/hr
column C2 pressure	30 psia	column C2 condenser duty	5013 kW
column C2 tray-12 temperature	129.7 °C	bypass flowrate of R2	156.1 kgmole/hr
		auxiliary reboiler 2 (R2) duty	392.1 kW
column C2 base level	50 %-level	cold inlet flowrate of R2	389.1 kgmole/hr
column C2 reflux drum level	50 %-level	column C2 product flowrate	120.7 kgmole/hr
column C3 feed flowrate	42.19 kgmole/hr	column C3 feed flowrate	42.19 kgmole/hr
column C3 pressure	76.32 psia	bypass flowrate of CR	25.76 kgmole/hr
avg C3-tray 1, 2, 3, and 4 temperature	326.7 °C	bypass flowrate of R3	120.2 kgmole/hr
		auxiliary reboiler 3 (R3) duty	15.75 kW
column C3 base level	50 %-level	column C3 bottom flowrate	2.643 kgmole/hr
column C3 reflux drum level	50 %-level	toluene recycle flowrate	39.55 kgmole/hr
column C3 boil-up flowrate	47.26 kgmole/hr	cold inlet flowrate of R3	47.26 kgmole/hr
column C3 reflux flowrate	9.94 kgmole/hr	column C3 reflux flowrate	9.94 kgmole/hr

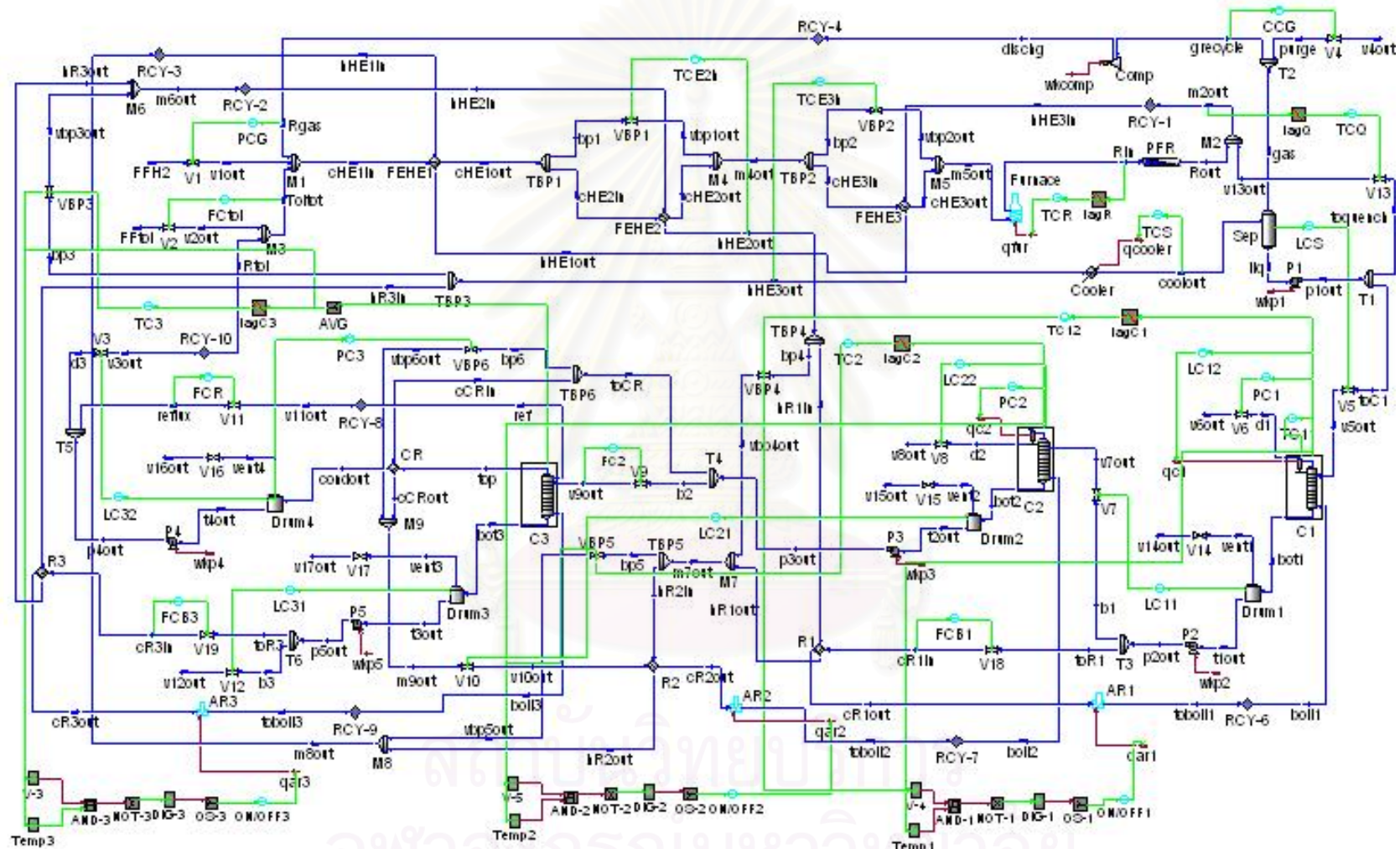

Figure 6.15: Control structures 2 of the HDA process with three auxiliary reboilers

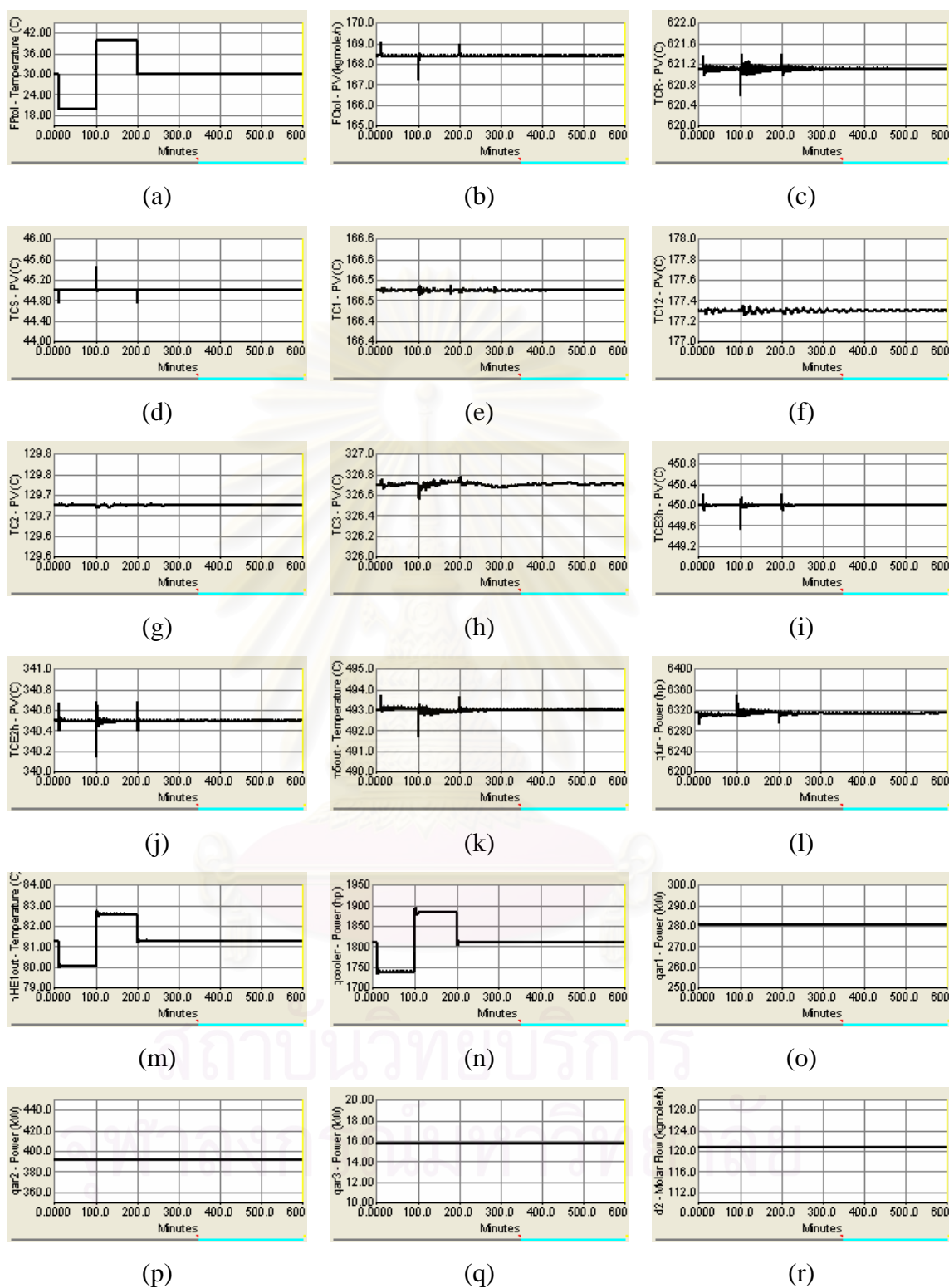

Figure 6.16: Dynamic responses of CS2 of the HDA process to a change in the disturbance load of the cold stream (reactor feed stream)

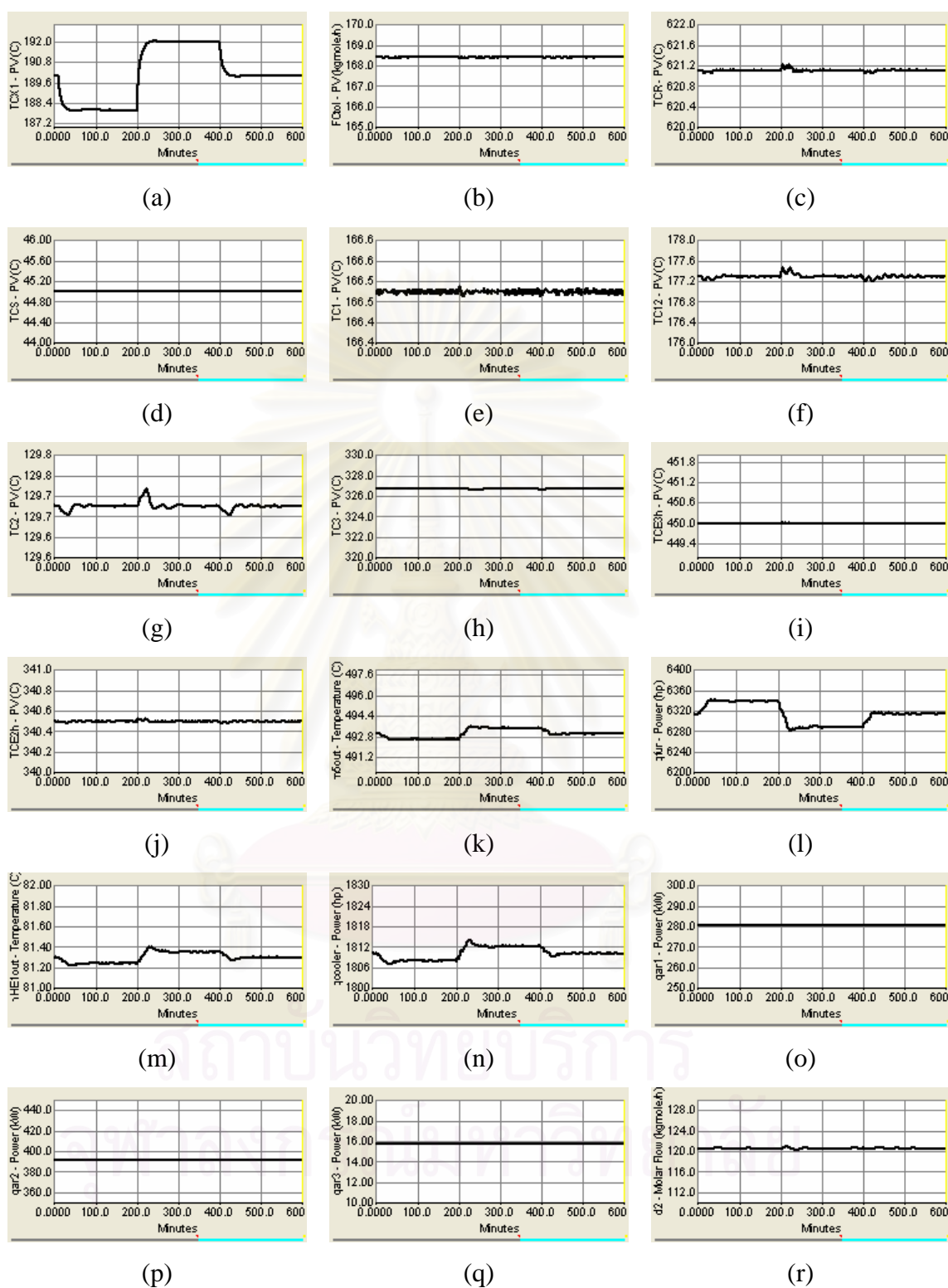

Figure 6.17: Dynamic responses of CS2 of the HDA process to a change in the disturbance load of the cold stream from the bottom of the stabilizer column

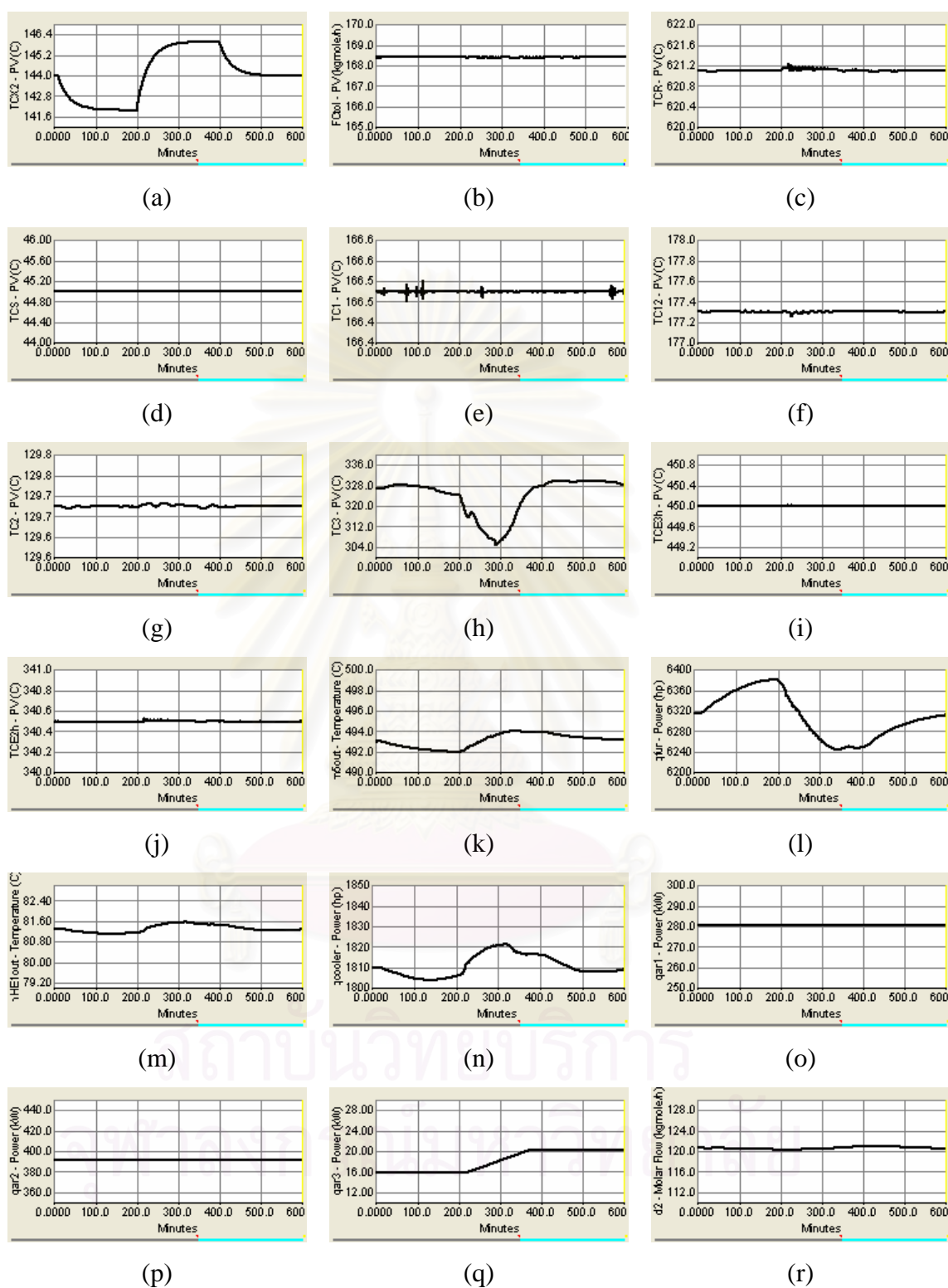

Figure 6.18: Dynamic responses of CS2 of the HDA process to a change in the disturbance load of the cold stream from the bottom of the product column

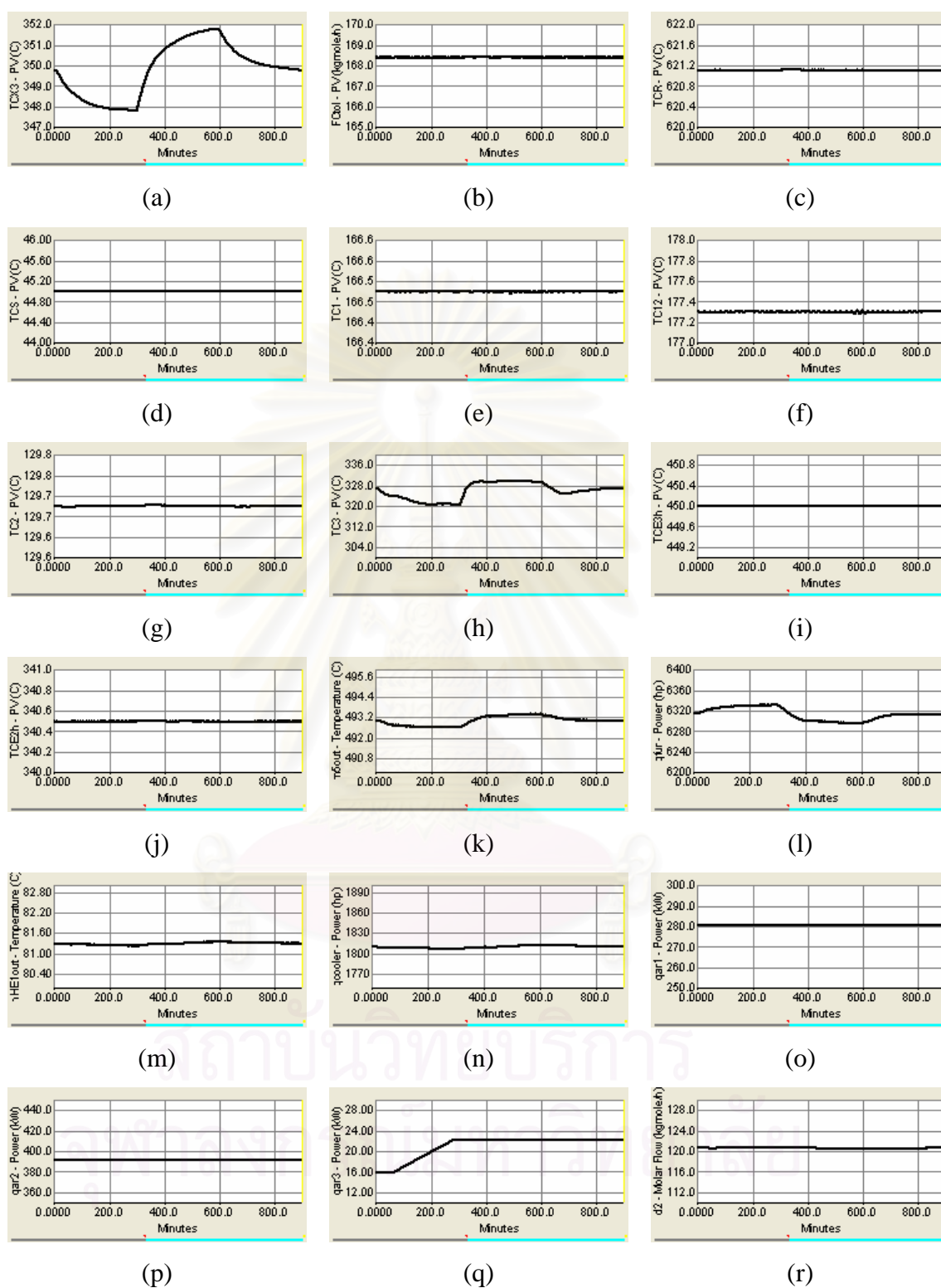

Figure 6.19: Dynamic responses of CS2 of the HDA process to a change in the disturbance load of the cold stream from the bottom of the recycle column

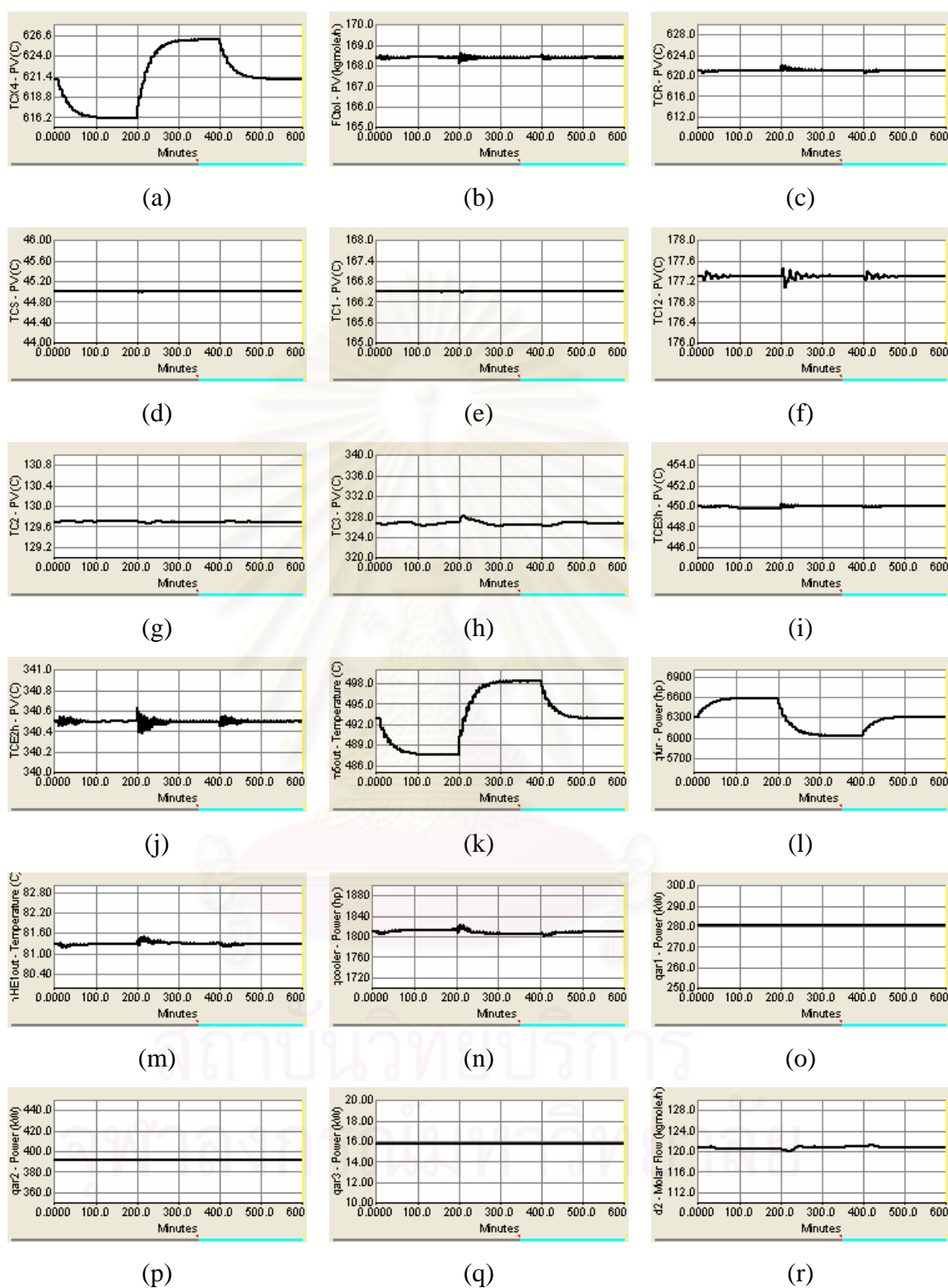

Figure 6.20: Dynamic responses of CS2 of the HDA process to a change in the disturbance load of the hot stream (reactor product)

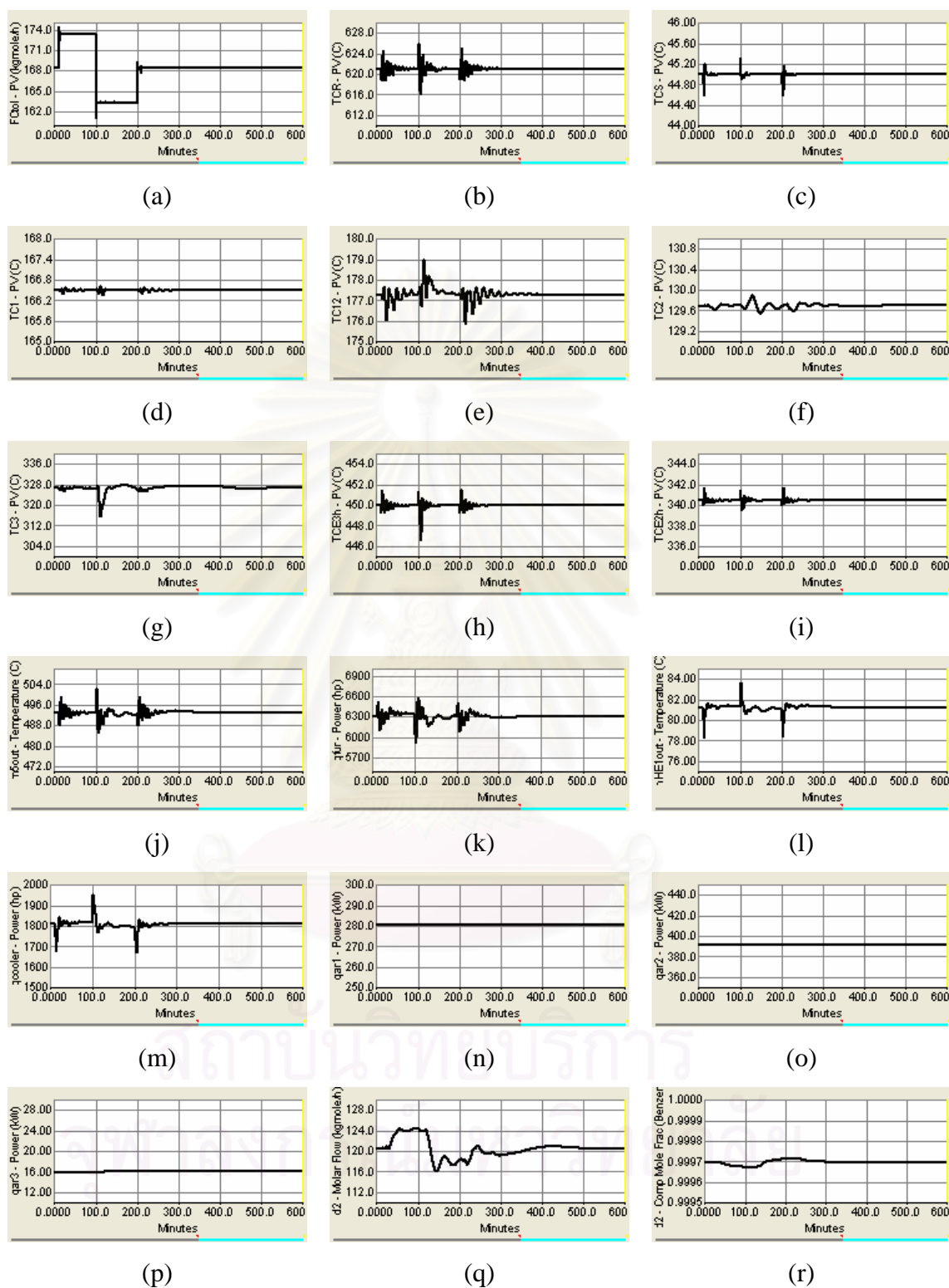

Figure 6.21: Dynamic responses of CS2 of the HDA process to a change in the total toluene feed flowrate

for the remaining loops.

6.4.1 Dynamic Simulation Results for HDA Process with three Auxiliary Reboilers: Control Structure 3

In order to illustrate the dynamic behavior of the control structure in HDA process alternative 6 with three auxiliary reboilers (CS3), several disturbance loads are made. The dynamic responses of the control system are shown in Figures 6.23 to 6.28. Results for individual disturbance load changes are as follows:

6.4.1.1 Change in the Disturbance Load of Cold Stream (Reactor Feed Stream)

Figure 6.23 shows the dynamic responses to a change in the disturbance load of cold stream (reactor feed stream). This disturbance is made as follows: first the fresh toluene feed temperature is decreased from 30°C to 20°C at time equals 10 minutes, and the temperature is increased from 20°C to 40°C at time equals 100 minutes, then its temperature is returned to its nominal value of 30°C at time equals 200 minutes.

The dynamic responses of this control structure are better than that of Base Case with three auxiliary reboilers when the change in the disturbance load of the cold stream happens. Particularly, the tray temperature in the recycle column provides a well controlled (Figure 6.23.h) because the feed flowrate of the recycle column is fixed for to reduce the propagation when disturbance occurs. In addition, the other dynamic responses are similar to the earlier control structures. The separator temperature and the tray temperature in the product column are well controlled (Figure 6.23.d and g) and the smooth control response happens in the tray temperature of the recycle column. But the small oscillations occur in the reactor inlet temperature and the tray temperature of the stabilizer column (Figure 6.23.c, e and f).

6.4.1.2 Change in the Disturbance Load of Cold Stream from the Bottoms of Stabilizer Column

Figure 6.24 shows the dynamic responses of HDA process alternative 6 (CS3) to a change in the disturbance load of cold stream which originating from the bottoms of the stabilizer column, by changing its temperature from 190°C to 188°C at time equals 10 minutes, and its temperature is increased from 188°C to 192°C at time equals 200 minutes, then its temperature is returned to its nominal value of 190°C at time equals 400 minutes.

As can be seen, the dynamic responses of this control structure are better than that of Base Case with three auxiliary reboilers during the change in the disturbance load of the cold stream from the bottoms of the stabilizer column happens. Particularly, the tray temperature in the recycle column provides a well controlled (Figure 6.24.h). Since, the feed flowrate of the recycle column is flow-controlled so the effect of disturbance does not propagate to downstream unit operations. Besides, the small oscillations occur in the reactor inlet temperature and the tray temperature of the stabilizer column as the same other control structures (Figure 6.24.c, e and f).

6.4.1.3 Change in the Disturbance Load of Cold Stream from the Bottoms of Product Column

Figure 6.25 shows the dynamic responses of HDA process to a change in the disturbance load of cold stream from the bottoms of the product column, by changing its temperature from 144°C to 142°C at time equals 10 minutes, and the its temperature is increased from 142°C to 146°C at time equals 200 minutes, then its temperature is returned to its nominal value of 144°C at time equals 400 minutes.

The dynamic responses of the CS3 are better than that of Base Case with three auxiliary reboilers as the change in the disturbance load of the cold stream from the bottoms of the product column occurs, since the performance of the tray temperature controlling in distillation column by auxiliary reboiler duty is better than that by the bypass valve. Particularly, the tray temperature in the recycle column provides a quite poor controlled (Figure 6.25.h). However, they are better

than that of the CS1 because the feed flowrate of the recycle column is flow-controlled in this control structure for to reduce the propagation of this change. For the other dynamic responses of this control structure, they are similar to the dynamic responses of the other control structures with three auxiliary reboilers when the same disturbance happens (i.e. the separator temperature, the reactor inlet temperature and the tray temperature in the stabilizer and product column (Figure 6.25.c, d, e, f and g)).

6.4.1.4 Change in the Disturbance Load of Cold Stream from the Bottoms of Recycle Column

Figure 6.26 shows the dynamic responses of HDA process alternative 6 (CS3) to a change in the disturbance load of cold stream from the bottoms of the product column, by changing its temperature from 349.8°C to 347.8°C at time equals 10 minutes, and the its temperature is increased from 347.8°C to 351.8°C at time equals 300 minutes, then its temperature is returned to its nominal value of 349.8°C at time equals 600 minutes.

The dynamic responses of the CS3 are worse than that of Base Case during the change in the disturbance load of the cold stream from the bottoms of the recycle column occurs, since the performance of the tray temperature controlling in distillation column by auxiliary reboiler duty is better than that by the bypass valve. As this disturbance occurs, the effect of this change is reduced before entering to the downstream unit operation, since the feed flowrate of recycle column is flow-controlled. Thus, the performances of the tray temperature control in the product and recycle column of this control structure are better than that of CS1 with three auxiliary reboilers. However, the other dynamic responses of this control structure are similar to the above control structures with three auxiliary reboilers. The separator temperature, the reactor inlet temperature and the tray temperature in the product column are quite well controlled (Figure 6.26.c, d and g). A deviation of 12°C happens in the tray temperature of the recycle column and it takes over 800 minutes to return to its nominal value of 326.7°C (Figure 6.26.h).

6.4.1.5 Change in the Disturbance Load of Hot Stream (Reactor Product)

Figure 6.27 shows the dynamic responses of HDA process to a change in the disturbance load of hot stream from reactor, by changing its temperature from 621.11°C to 616.11°C at time equals 10 minutes, and the its temperature is increased from 616.11°C to 626.11°C at time equals 200 minutes, then its temperature is returned to its nominal value of 621.11°C at time equals 400 minutes.

The dynamic responses of this control structure are better than that of Base Case when the change in the disturbance load of the hot stream occurs, since the feed flowrate of the recycle column is flow-controlled. Then, the effect of this disturbance does not propagate to downstream unit operation like recycle column. Thus, the tray temperatures in the product and recycle column provide well controlled (Figure 6.27.g and h). The separator temperature, the reactor inlet temperature is slightly well controlled (Figure 6.27.c) but the oscillation happens in the tray temperature of the stabilizer column (Figure 6.27.e and f).

6.4.1.6 Change in the Total Toluene Feed Flowrate

Figure 6.28 shows the dynamic responses of HDA process to a change in the total toluene feed flowrates from 168.4 kgmole/hr to 173.4 kgmole/hr at time equals 10 minutes, and the its feed flowrate is decreased from 173.4 kgmole/hr to 163.4 kgmole/hr at time equals 100 minutes, then its flowrates is returned to its nominal value of 168.4 kgmole/hr at time equals 200 minutes.

The dynamic responses of CS3 are better than that of the Base Case when this disturbance occurs. Particularly, the tray temperature in the recycle column provides the well controlled (Figure 6.28.g) because the feed flowrate of the recycle column is flow-controlled for reducing the material and flow propagation during the disturbance occurs. In addition, the separator temperature is quite well controlled (Figure 6.28.c), the oscillations occur in the tray temperature of the stabilizer column and the reactor inlet temperature (Figure 6.28.b, d and e). A deviation of 10oC happens in the tray temperature of the recycle column.

Table 6.4 The initial values of controlled and manipulated variables for HDA process with three auxiliary reboilers: Control Structure 3

Controlled variable		Manipulated variable	
Process variable	Initial value	Process variable	Initial value
total toluene flowrate	168.4 kgmole/hr	fresh toluene feed flowrate	128.8 kgmole/hr
gas recycle stream pressure	605 psia	fresh hydrogen feed flowrate	220.4 kgmole/hr
methane in gas recycle	0.5877 mole-frac	purge flowrate	217.5 kgmole/hr
quenched temperature	621.1 °C	quench flowrate	48.49 kgmole/hr
reactor inlet temperature	621.1 °C	furnace duty	4708 kW
separator temperature	45 °C	cooler duty	1350 kW
hot outlet temperature of FEHE 2	340.5 °C	bypass flowrate of FEHE 2	291 kgmole/hr
hot outlet temperature of FEHE 3	450 °C	bypass flowrate of FEHE 3	200.5 kgmole/hr
separator liquid level	50 %-level	column C1 feed flowrate	171.4 kgmole/hr
column C1 pressure	150 psia	column C1 condenser duty	389.1 kW
column C1 tray-3 temperature	177.3 °C	bypass flowrate of R1	593.4 kgmole/hr
		auxiliary reboiler 1 (R1) duty	280.6 kW
column C1 tray-6 temperature	166.5 °C	column C1 gas flowrate	8.494 kgmole/hr
column C1 base level	50 %-level	column C2 feed flowrate	162.9 kgmole/hr
column C1 reflux drum level	50 %-level	column C1 reflux flowrate	32.67 kgmole/hr
column C1 boil-up flowrate	183 kgmole/hr	cold inlet flowrate of R1	183 kgmole/hr
column C2 pressure	30 psia	column C2 condenser duty	5013 kW
column C2 tray-12 temperature	129.7 °C	bypass flowrate of R2	156.1 kgmole/hr
		auxiliary reboiler 2 (R2) duty	392.1 kW
column C2 base level	50 %-level	cold inlet flowrate of R2	389.1 kgmole/hr
column C2 reflux drum level	50 %-level	column C2 product flowrate	120.7 kgmole/hr
column C3 feed flowrate	42.19 kgmole/hr	column C3 feed flowrate	42.19 kgmole/hr
column C3 pressure	76.32 psia	bypass flowrate of CR	25.76 kgmole/hr
avg C3-tray 1, 2, 3, and 4 temperature	326.7 °C	bypass flowrate of R3	120.2 kgmole/hr
		auxiliary reboiler 3 (R3) duty	15.75 kW
column C3 base level	50 %-level	column C3 bottom flowrate	2.643 kgmole/hr
column C3 reflux drum level	50 %-level	toluene recycle flowrate	39.55 kgmole/hr
column C3 boil-up flowrate	47.26 kgmole/hr	cold inlet flowrate of R3	47.26 kgmole/hr
column C3 reflux flowrate	9.94 kgmole/hr	column C3 reflux flowrate	9.94 kgmole/hr

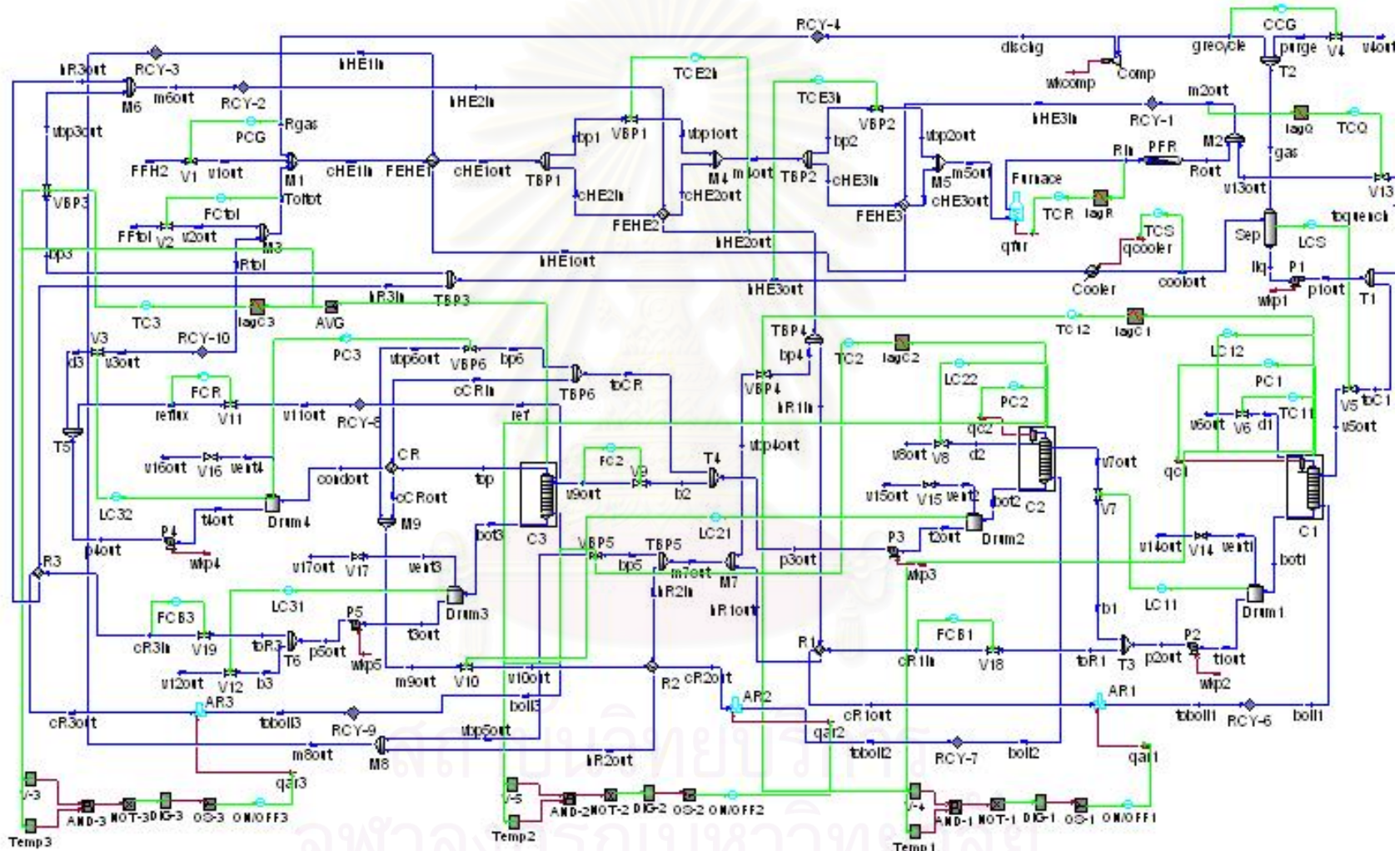

Figure 6.22: Control structures 3 of the HDA process with three auxiliary reboilers

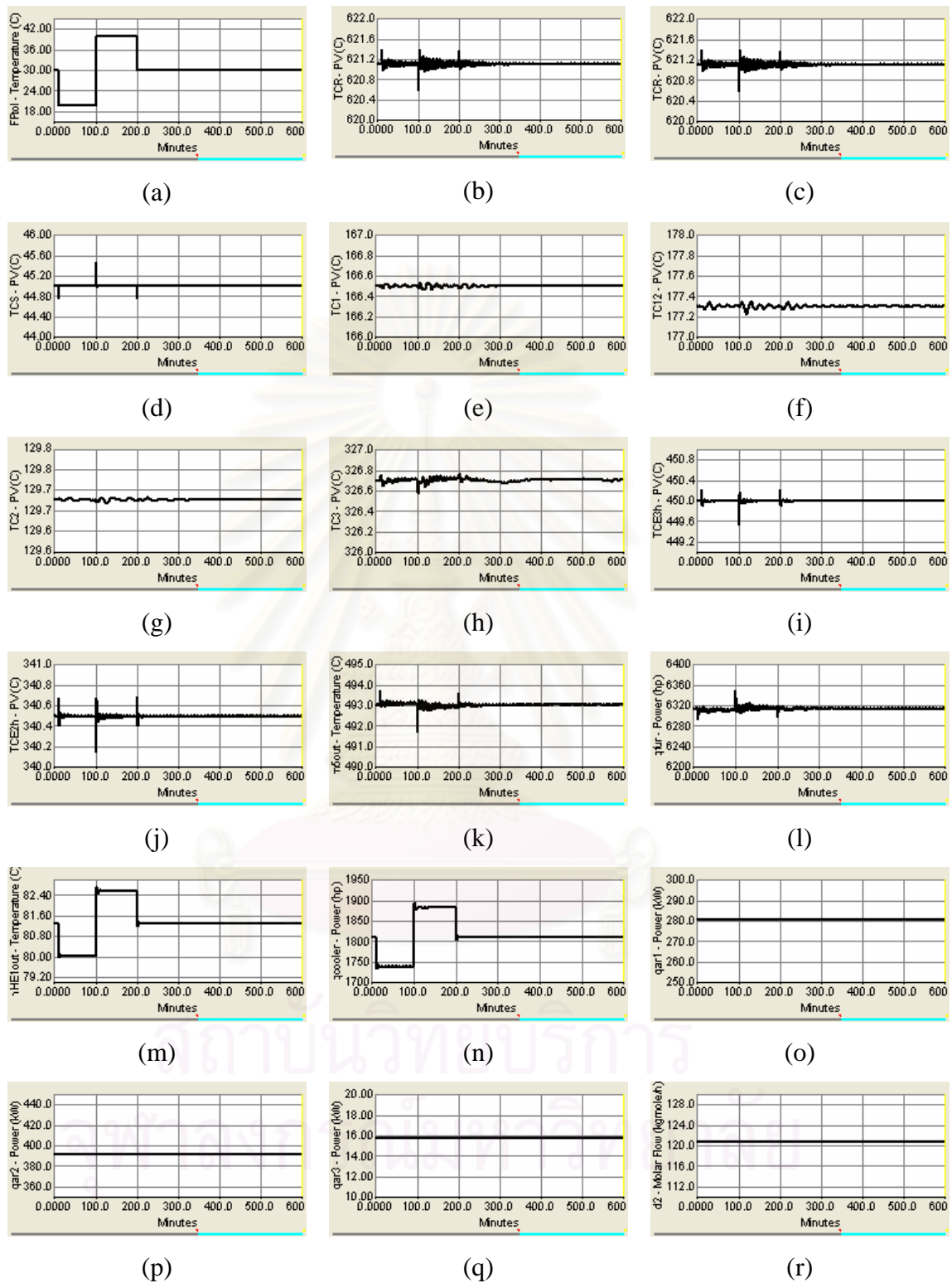

Figure 6.23: Dynamic responses of CS3 of the HDA process to a change in the disturbance load of cold stream (reactor feed stream)

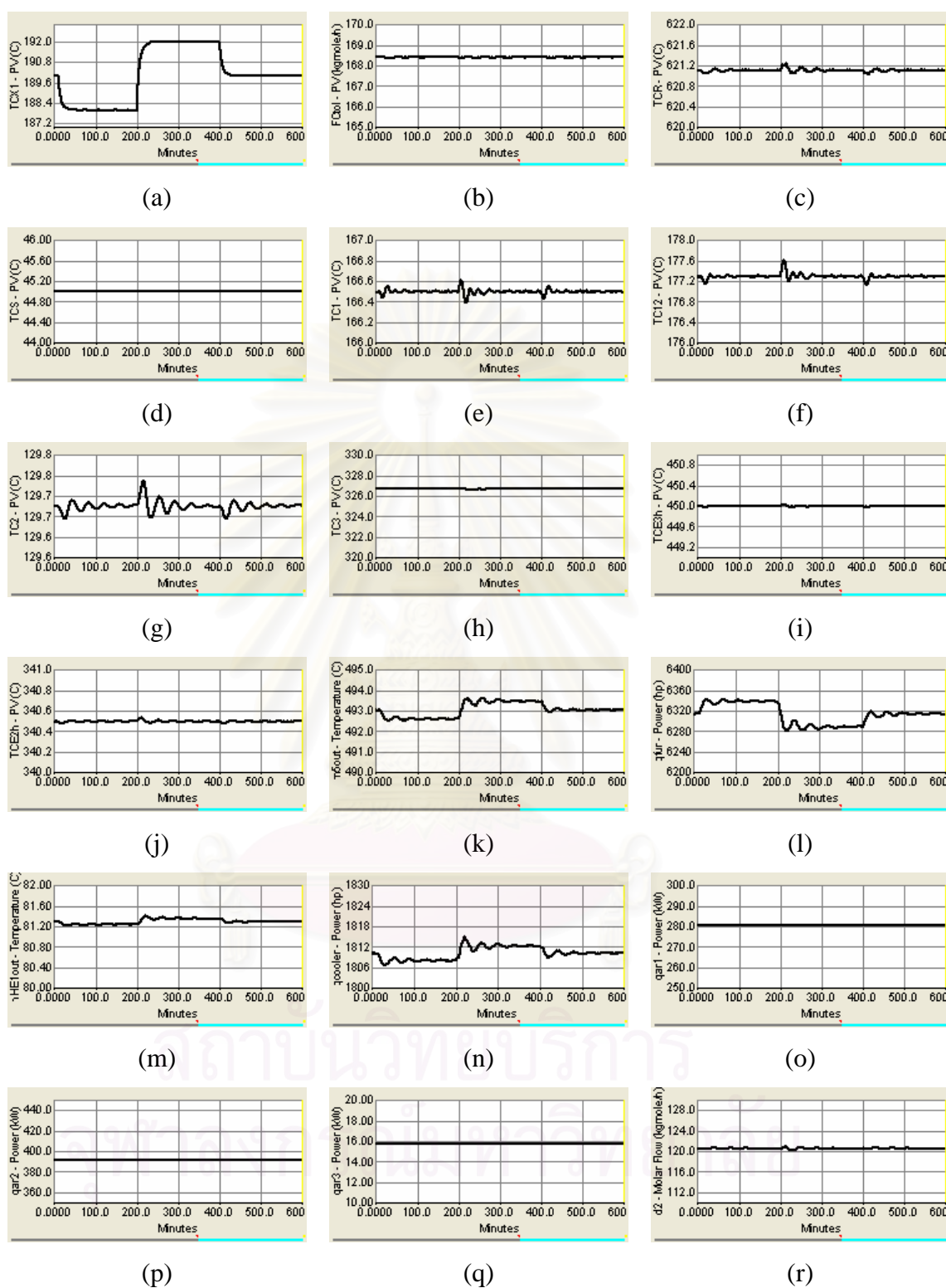

Figure 6.24: Dynamic responses of CS3 of the HDA process to a change in the disturbance load of cold stream from the bottom of the stabilizer column

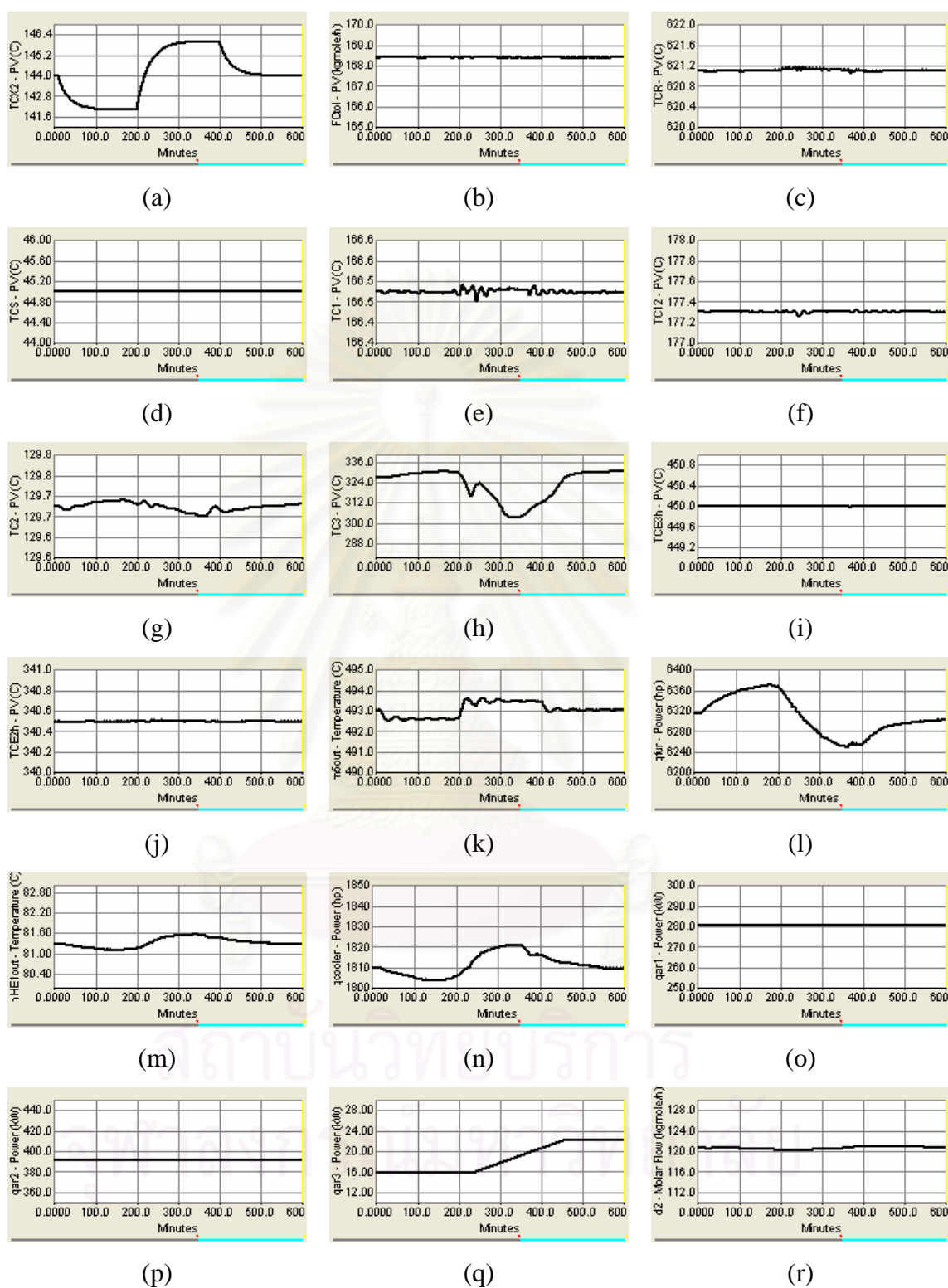

Figure 6.25: Dynamic responses of CS3 of the HDA process to a change in the disturbance load of cold stream from the bottom of the product column

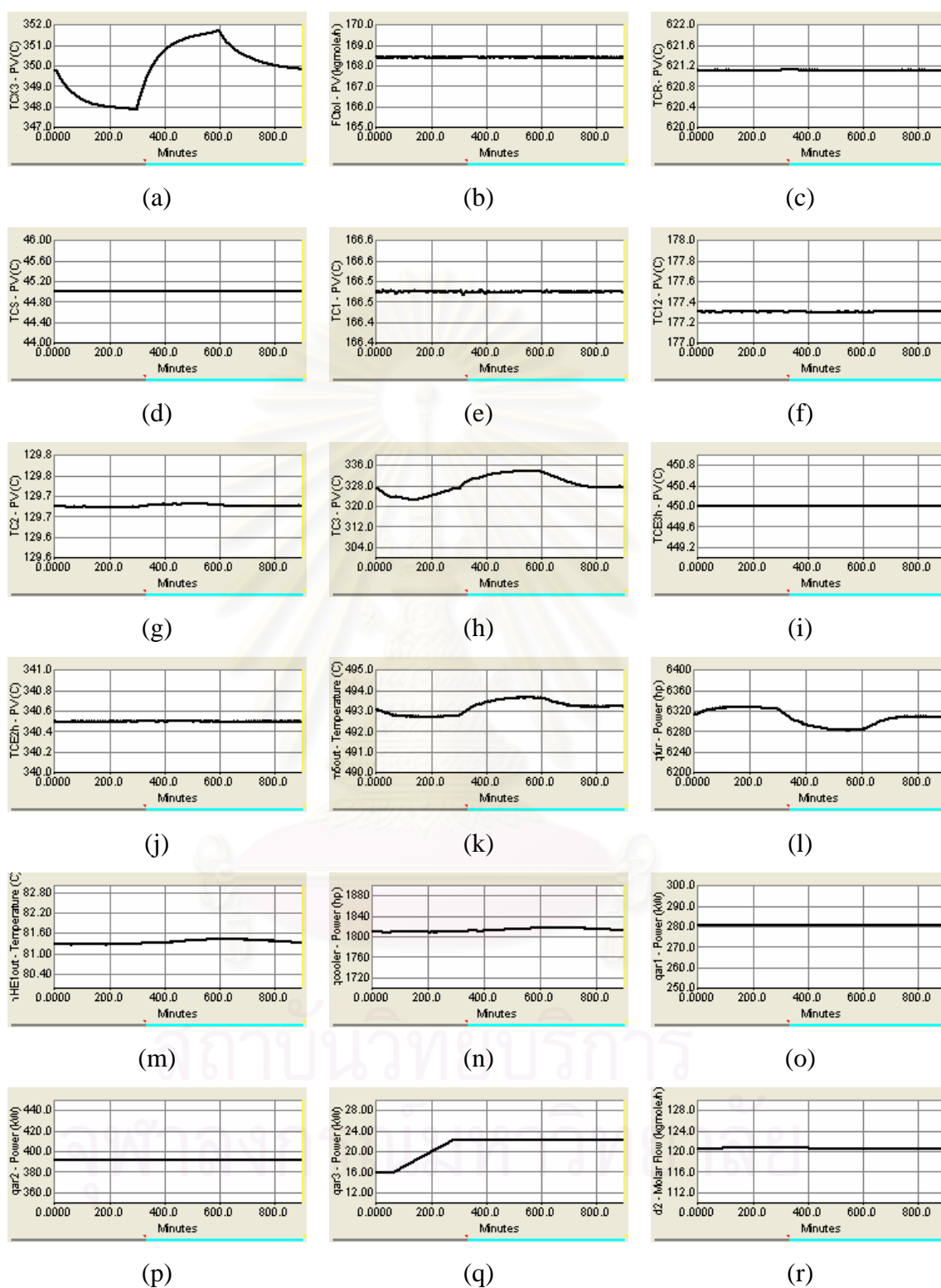

Figure 6.26: Dynamic responses of CS3 of the HDA process to a change in the disturbance load of cold stream from the bottom of the recycle column

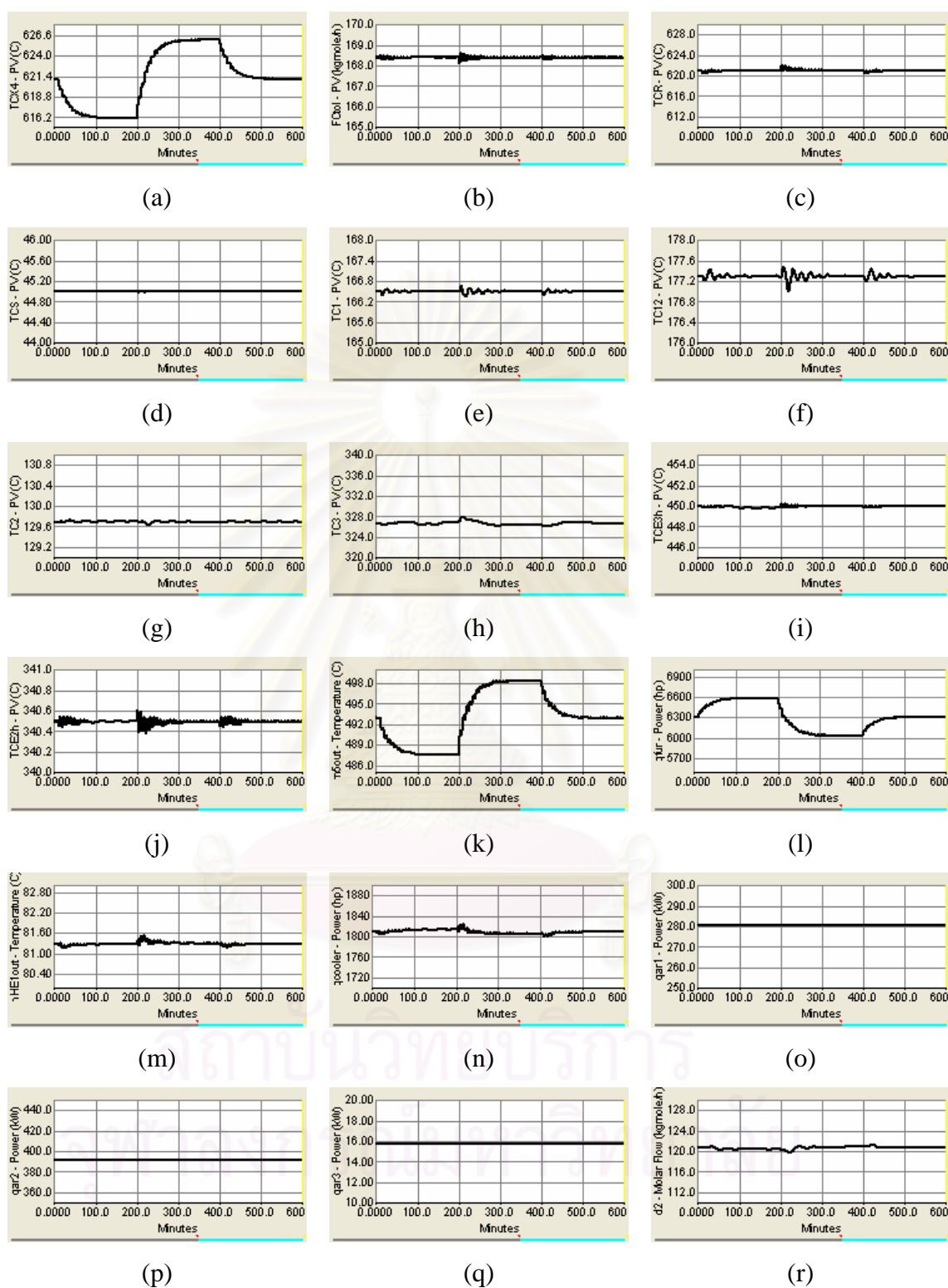

Figure 6.27: Dynamic responses of CS3 of the HDA process to a change in the disturbance load of hot stream (reactor product)

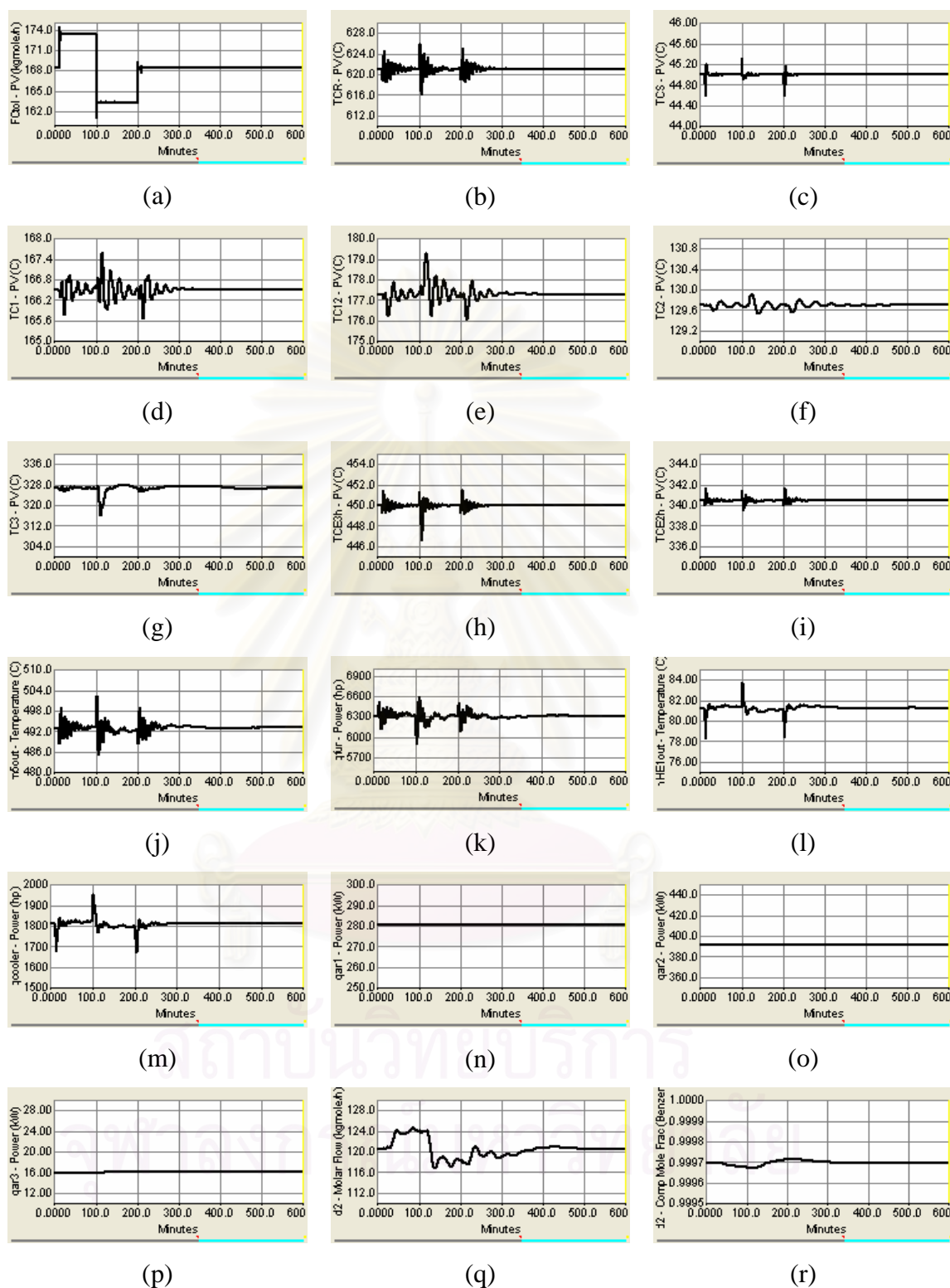

Figure 6.28: Dynamic responses of CS3 of the HDA process to a change in the total toluene feed flowrate

6.5 Design of plantwide Control for HDA Process with Minimum Auxiliary Reboilers: Base Case

The plantwide control structure for energy-integrated HDA process with minimum auxiliary reboilers (Base Case) is shown in Figure 6.29. Its major loops are the same as those used in Base Case of the HDA process with three auxiliary reboilers, except for the tray temperature control in the stabilizer column and the recycle column. From the previous chapter, only an auxiliary reboiler (R2) is needed for to guarantee a workable HDA process.

Since the hot reactor product is used to drive all reboilers in three columns. In this control structure, part of this stream in the process-to-process exchanger is bypassed and manipulated to control the tray temperatures in the stabilizer and recycle column, but the auxiliary reboiler (R2) duty is manipulated to control the tray temperature in the product column. The hot outlet temperatures of FEHE 2 and FEHE 3 (the temperature at the entrance of the auxiliary reboilers, R2 and R3 respectively) are controlled by manipulating bypass valve on the cold stream to prevent the propagation of thermal disturbance to the separation section. In the recycle column, the cold inlet stream of condenser/reboiler (CR) is bypassed and manipulated to control its pressure column. In addition, the averaging tray temperature control in the recycle column is used instead of a single tray temperature control in order to reduce the deviation of temperature response during the disturbance occur. The initial values of all of the controlled and manipulated variables come from steady state simulation and listed in Table 6.5. The control structure and controller parameters are shown in Table C.5. In this work, the type of controller for each control loop is different. P controllers are employed for the level loops, PID controllers are employed for the temperature loops and PI controllers are employed for the remaining loops.

6.5.1 Dynamic Simulation Results for HDA Process with Minimum Auxiliary Reboilers: Base Case

In order to illustrate the dynamic behavior of the Base Case control structure in HDA process alternative 6 with minimum auxiliary reboilers, several disturbance loads are made. The dynamic responses of the control system are shown in Figures 6.30 to 6.35. Results for individual disturbance load changes are as follows:

6.5.1.1 Change in the Disturbance Load of Cold Stream (Reactor Feed Stream)

Figure 6.30 shows the dynamic responses to a change in the disturbance load of cold stream (reactor feed stream). This disturbance is made as follows: first the fresh toluene feed temperature is decreased from 30°C to 20°C at time equals 10 minutes, and the temperature is increased from 20°C to 40°C at time equals 100 minutes, then its temperature is returned to its nominal value of 30°C at time equals 200 minutes.

The dynamic responses of the Base Case with minimum auxiliary reboiler are similar to the control structures with three auxiliary reboilers when this disturbance occurs. Again, both the cold and hot outlet temperatures of FEHE1 decrease as the cold inlet temperature decreases. As a result, the hot outlet temperature of FEHE1 drops to a new steady state value and the cooler duty decreases (Figure 6.30.l and m). The positive disturbance load of the cold stream will result in increase of the small furnace duty (Figure 6.30.k).

When the cold inlet temperature of FEHE1 increases, both the cold and hot outlet temperatures of FEHE1 increase. Again, the hot outlet temperature of FEHE1 quickly increases to a new steady state value, so the cooler duty increases. The negative disturbance load of the cold stream will result in decrease of the small furnace duty.

The separator temperature and the tray temperature in the product column are well controlled (Figure 6.30.d and f) but the reactor inlet temperature and the tray temperature in the stabilizer column have small oscillation (Figure 6.30.c and e). In addition, the tray temperature in the recycle column has a small deviation about 0.6°C and it takes a long time to return to its nominal value of 326.7°C (Figure 6.30.g).

6.5.1.2 Change in the Disturbance Load of Cold Stream from the Bottoms of Stabilizer Column

Figure 6.31 shows the dynamic responses of Base case of HDA process alternative 6 to a change in the disturbance load of cold stream which originating from the bottoms of the stabilizer column, by changing its temperature from 190°C to 188°C at time equals 10 minutes, and its temperature is increased from 188°C to 192°C at time equals 200 minutes, then its temperature is returned to its nominal value of 190°C at time equals 400 minutes.

Again, both the positive and negative disturbance loads of the cold stream from the bottoms of the stabilizer column are shifted to the hot stream. The positive disturbance load (i.e. when the temperature decreases) will decrease the hot inlet temperature of FEHE1 (i.e. become a negative disturbance load for the hot stream). As a result, the hot outlet temperature of FEHE1 and the inlet temperature of the furnace drop to a new steady state value (Figure 6.31.j and l). Thus, they will result in decrease of the cooler duty and increase of the furnace duty, respectively (Figure 6.31.k and m). On the other hand, when the temperature of the cold stream increases, its negative disturbance load causes a positive disturbance load for the hot stream. As a result, the hot outlet temperature of FEHE1 increase, So it will result in increase of the cooler duty and the furnace duty decreases, since the furnace inlet temperature increases. In addition, the separator temperature is well controlled (Figure 6.31.d), the small oscillations happen in the reactor inlet temperature and the tray temperature in the stabilizer column (Figure 6.31.c and e) but a deviation about 4°C occurs in the tray temperature of the recycle column and it takes more than a long time to

return to its nominal value 326.7°C (Figure 6.31.g).

6.5.1.3 Change in the Disturbance Load of Cold Stream from the Bottoms of Product Column

Figure 6.32 shows the dynamic responses of HDA process to a change in the disturbance load of cold stream from the bottoms of the product column, by changing its temperature from 144°C to 142°C at time equals 10 minutes, and the its temperature is increased from 142°C to 146°C at time equals 200 minutes, then its temperature is returned to its nominal value of 144°C at time equals 400 minutes.

The dynamic responses of the Base Case with minimum auxiliary reboiler are similar to the dynamic response of the Base Case with three auxiliary reboilers. Again, both positive and negative disturbance loads originating from the bottoms of product column are shifted to the hot stream, when the temperature decreases; it will result in decrease of the hot inlet temperature of FEHE1. Then, the hot outlet temperature of FEHE1 slowly drops (Figure 6.32.l). Therefore, the cooler duty decreases significantly (Figure 6.32.m), since the cooler inlet temperature decreases. But, the furnace duty increases because the furnace inlet temperature decreases (Figure 6.32.j and k). On the other hand, when the temperature increases, it will result in increase of the hot inlet temperature of FEHE1. Then, the hot outlet temperature of FEHE1 slowly increases. Therefore, the cooler duty increases but the furnace duty decreases significantly, since the furnace inlet temperature increases.

In this control structure, a large deviation about 20°C occurs in the tray temperature of the recycle column and it takes long time to return to its nominal value of 326.7°C (Figure 6.32.g). Besides, the separator temperature is well controlled (Figure 6.32.d) but the small oscillations happen in the reactor inlet temperature and the tray temperature in the stabilizer and product column (Figure 6.32.c and e).

6.5.1.4 Change in the Disturbance Load of Cold Stream from the Bottoms of Recycle Column

Figure 6.33 shows the dynamic responses of HDA process alternative 6 (Base Case) to a change in the disturbance load of cold stream from the bottoms of the recycle column, by changing its temperature from 349.8°C to 347.8°C at time equals 10 minutes, and the its temperature is increased from 347.8°C to 351.8°C at time equals 300 minutes, then its temperature is returned to its nominal value of 349.8°C at time equals 600 minutes.

Again, when the cold temperature decreases, then the hot outlet temperature of reboiler (R3) decreases. Consequently, the furnace duty increases, since the furnace inlet temperature decreases (Figure 6.33.j and k). On the other hand, when the cold temperature increases, then the hot outlet temperature of reboiler (R3) increases. Therefore, the furnace duty will be decreased, since the furnace inlet temperature increases. Besides, the dynamic responses of this control structure are similar to the CS with three auxiliary reboilers (i.e. the separator temperature, the reactor inlet temperature and the tray temperature in the product column are quite well controlled (Figure 6.33.c, d and f), the oscillation occurs in the tray temperature of the stabilizer column (Figure 6.33.e).). But a deviation about 6°C happens in the tray temperature of the recycle column and it takes long time to return to its nominal value (Figure 6.33.g).

6.5.1.5 Change in the Disturbance Load of Hot Stream (Reactor Product)

Figure 6.34 shows the dynamic responses of HDA process to a change in the disturbance load of hot stream from reactor, by changing its temperature from 621.11°C to 616.11°C at time equals 10 minutes, and the its temperature is increased from 616.11°C to 626.11°C at time equals 200 minutes, then its temperature is returned to its nominal value of 621.11°C at time equals 400 minutes.

Again, when the hot temperature decreases, it will result in decrease of the furnace inlet temperature (Figure 6.34.j). As a result, the furnace duty increases

(Figure 6.34.k). On the other hand, when the hot temperature increases, the furnace duty will be decreased, since the furnace inlet temperature increases.

The separator temperature and the reactor inlet temperature are slightly well controlled (Figure 6.34.c and d) but small oscillations happen in the tray temperature of the stabilizer and product column (Figure 6.34.e and f). Besides, the tray temperature in the recycle has a deviation about 8°C and it takes more than long time to return to its nominal value 326.7°C (Figure 6.34.g).

6.5.1.6 Change in the Total Toluene Feed Flowrate

Figure 6.35 shows the dynamic responses of HDA process to a change in the total toluene feed flowrates from 168.4 kgmole/hr to 173.4 kgmole/hr at time equals 10 minutes, and the its feed flowrate is decreased from 173.4 kgmole/hr to 163.4 kgmole/hr at time equals 100 minutes, then its flowrates is returned to its nominal value of 168.4 kgmole/hr at time equals 200 minutes.

As can be see that the dynamic responses of the Base Case with minimum auxiliary reboiler is similar to the previous control structures with three auxiliary reboilers when this disturbance occurs. A deviation about 4.5°C happens in the tray temperature of the stabilizer column (Figure 6.35.d), but the separator temperature is slightly well controlled (Figure 6.35.c). The tray temperature in the recycle column has a large deviation of 48°C and it takes more than 500 minutes to return to its nominal value of 326.7°C (Figure 6.35.f). In addition, the oscillations occur in the reactor inlet temperature (Figure 6.35.b).

6.6 Design of plantwide Control for HDA Process with Minimum Auxiliary Reboilers: Control Structure 1

The new plantwide control structure for energy-integrated HDA process with minimum auxiliary reboilers (CS1) is shown in Figure 6.36. Its major loops

Table 6.5 The initial values of controlled and manipulated variables for HDA process with minimum auxiliary reboilers: Base Case

Controlled variable		Manipulated variable	
Process variable	Initial value	Process variable	Initial value
total toluene flowrate	168.4 kgmole/hr	fresh toluene feed flowrate	128.9 kgmole/hr
gas recycle stream pressure	605 psia	fresh hydrogen feed flowrate	220.5 kgmole/hr
methane in gas recycle	0.5877 mole-frac	purge flowrate	217.5 kgmole/hr
quenched temperature	621.1 °C	quench flowrate	48.5 kgmole/hr
reactor inlet temperature	621.1 °C	furnace duty	4796 kW
separator temperature	45 °C	cooler duty	1339 kW
hot outlet temperature of FEHE 2	340.5 °C	bypass flowrate of FEHE 2	266.7 kgmole/hr
hot outlet temperature of FEHE 3	450 °C	bypass flowrate of FEHE 3	180.9 kgmole/hr
separator liquid level	50 %-level	column C1 feed flowrate	171.3 kgmole/hr
column C1 pressure	150 psia	column C1 gas flowrate	8.677 kgmole/hr
column C1 tray-6 temperature	166.5 °C	bypass flowrate of R1	585.8 kgmole/hr
column C1 base level	50 %-level	column C2 feed flowrate	162.7 kgmole/hr
column C1 reflux drum level	50 %-level	column C1 condenser duty	370.2 kW
column C1 boil-up flowrate	183 kgmole/hr	cold inlet flowrate of R1	183 kgmole/hr
column C2 pressure	30 psia	column C2 condenser duty	5016 kW
column C2 tray-12 temperature	129.7 °C	auxiliary reboiler 2 (R2) duty	572.4 kW
column C2 base level	50 %-level	column C3 feed flowrate	42.16 kgmole/hr
column C2 reflux drum level	50 %-level	column C2 product flowrate	120.5 kgmole/hr
column C2 boil-up flowrate	385 kgmole/hr	cold inlet flowrate of R2	385 kgmole/hr
column C3 pressure	76.32 psia	bypass flowrate of CR	26.32 kgmole/hr
avg C3-tray 1, 2, 3, and 4 temperature	326.7 °C	bypass flowrate of R3	177.3 kgmole/hr
column C3 base level	50 %-level	column C3 bottom flowrate	2.644 kgmole/hr
column C3 reflux drum level	50 %-level	toluene recycle flowrate	39.52 kgmole/hr
column C3 boil-up flowrate	47.26 kgmole/hr	cold inlet flowrate of R3	47.26 kgmole/hr
column C3 reflux flowrate	9.94 kgmole/hr	column C3 reflux flowrate	9.94 kgmole/hr

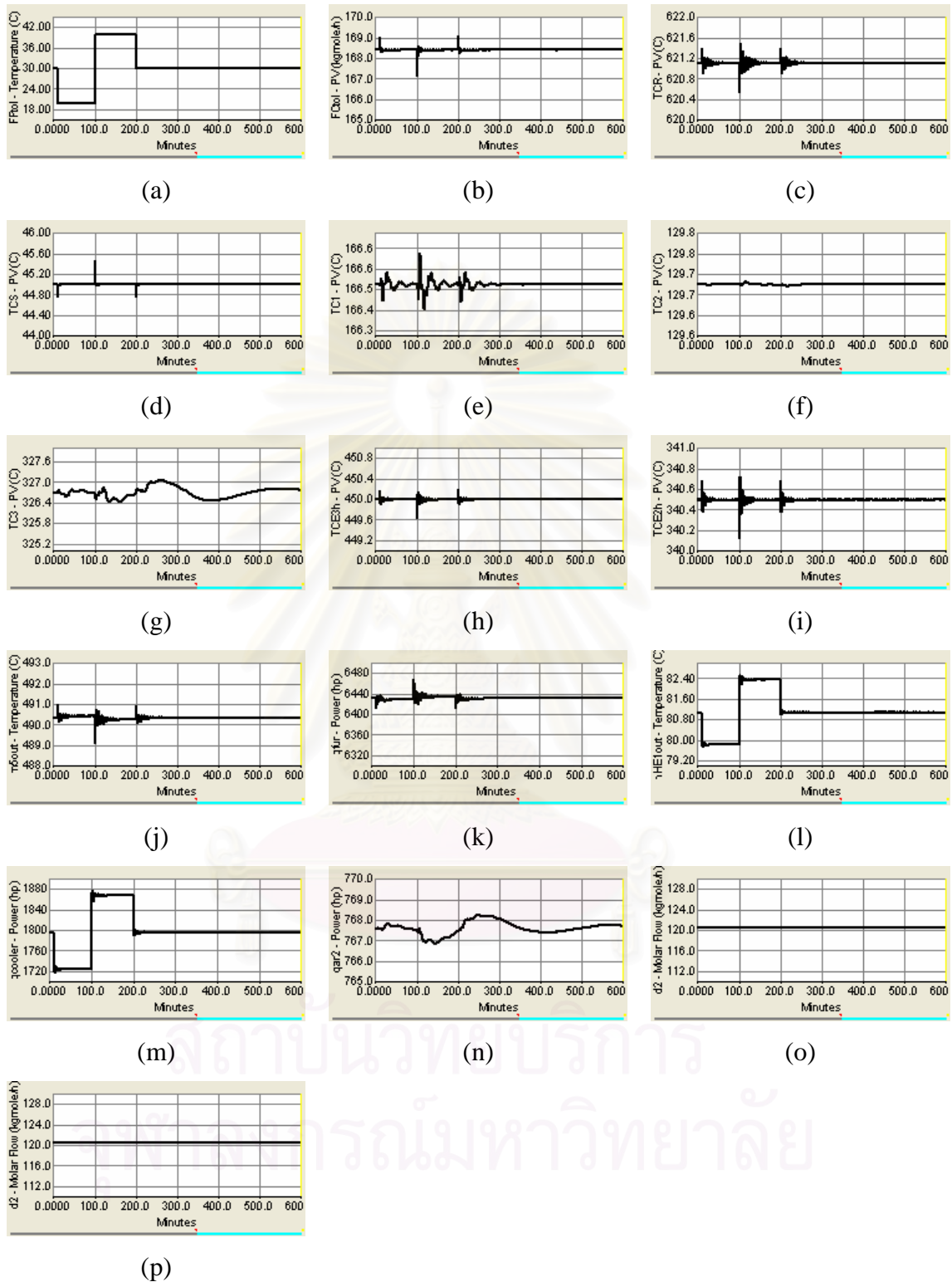

Figure 6.30: Dynamic responses of Base Case of the HDA process with minimum auxiliary reboiler to a change in the disturbance load of cold stream (reactor feed stream)

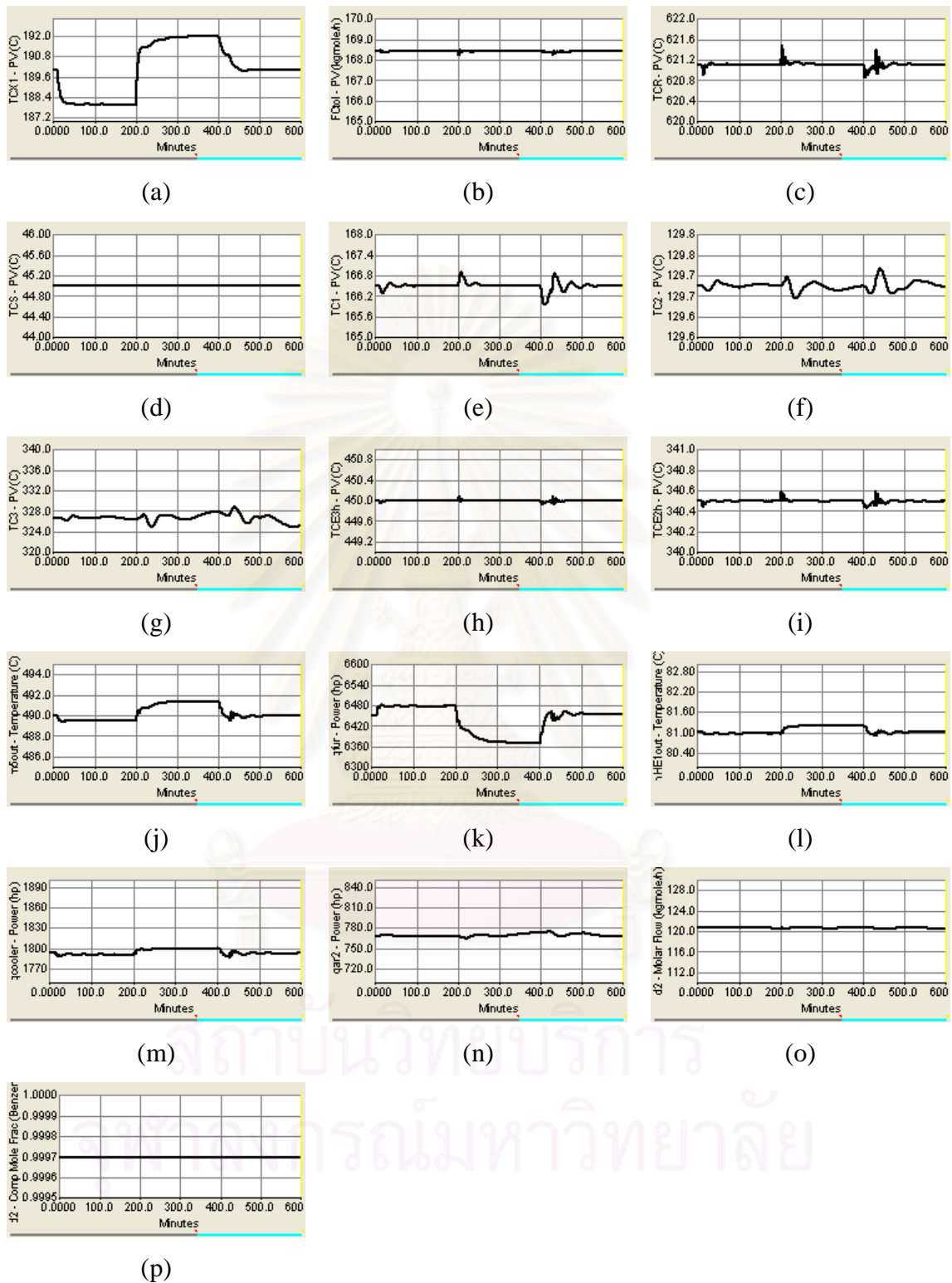

Figure 6.31: Dynamic responses of Base Case of the HDA process with minimum auxiliary reboiler to a change in the disturbance load of cold stream from the bottom of the stabilizer column

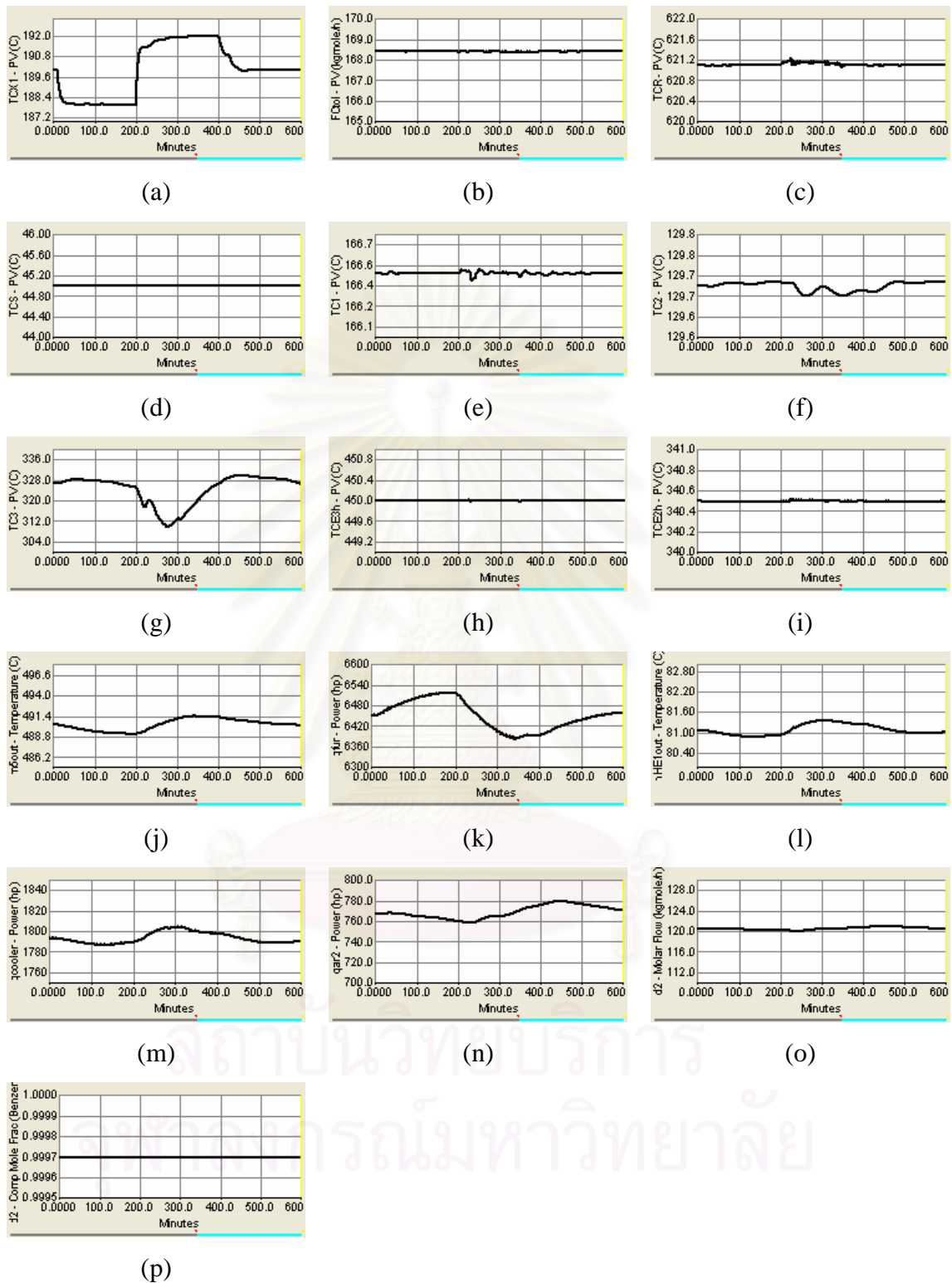

Figure 6.32: Dynamic responses of Base Case of the HDA process with minimum auxiliary reboiler to a change in the disturbance load of cold stream from the bottom of the product column

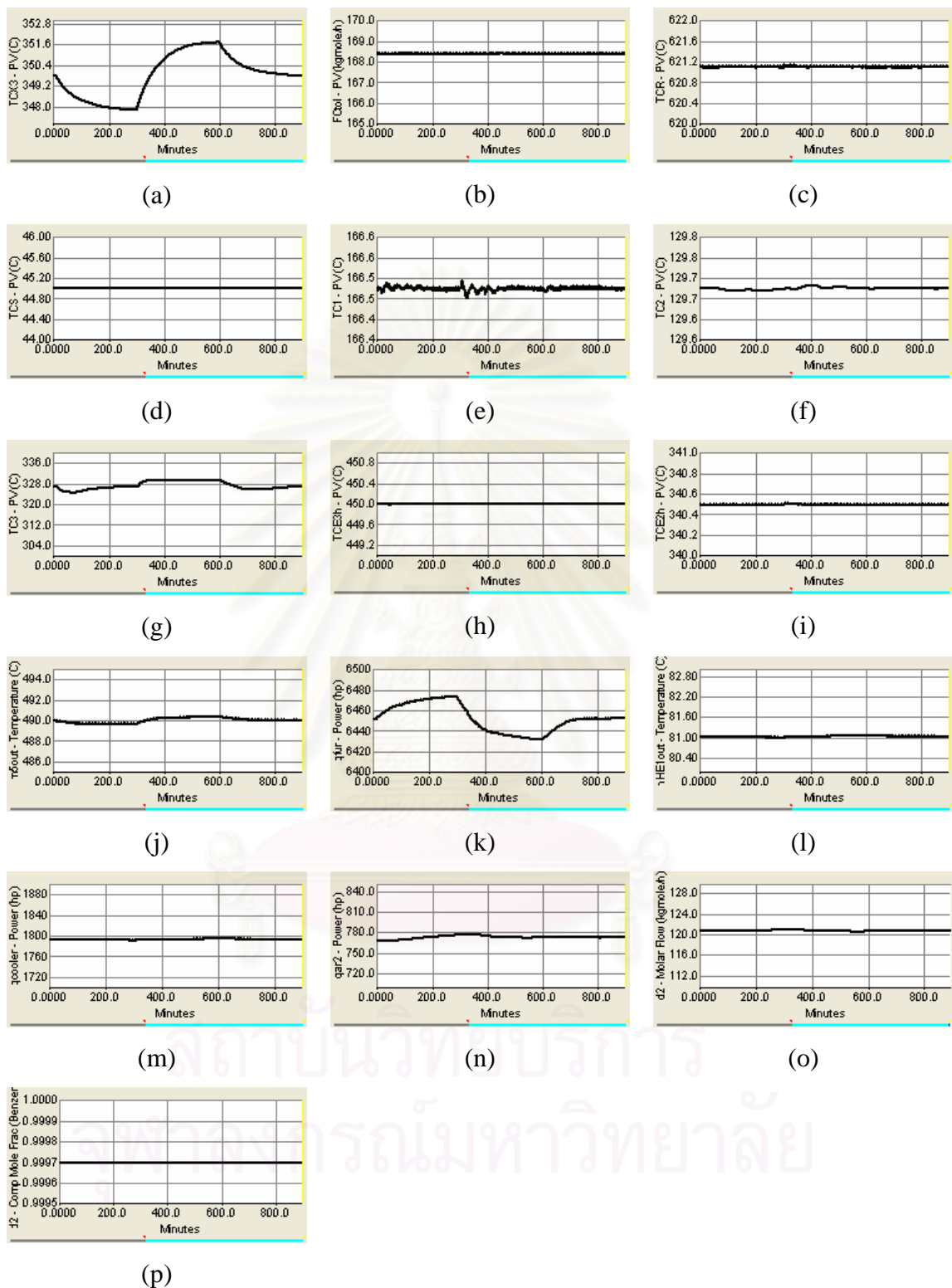

Figure 6.33: Dynamic responses of Base Case of the HDA process with minimum auxiliary reboiler to a change in the disturbance load of cold stream from the bottom of the recycle column

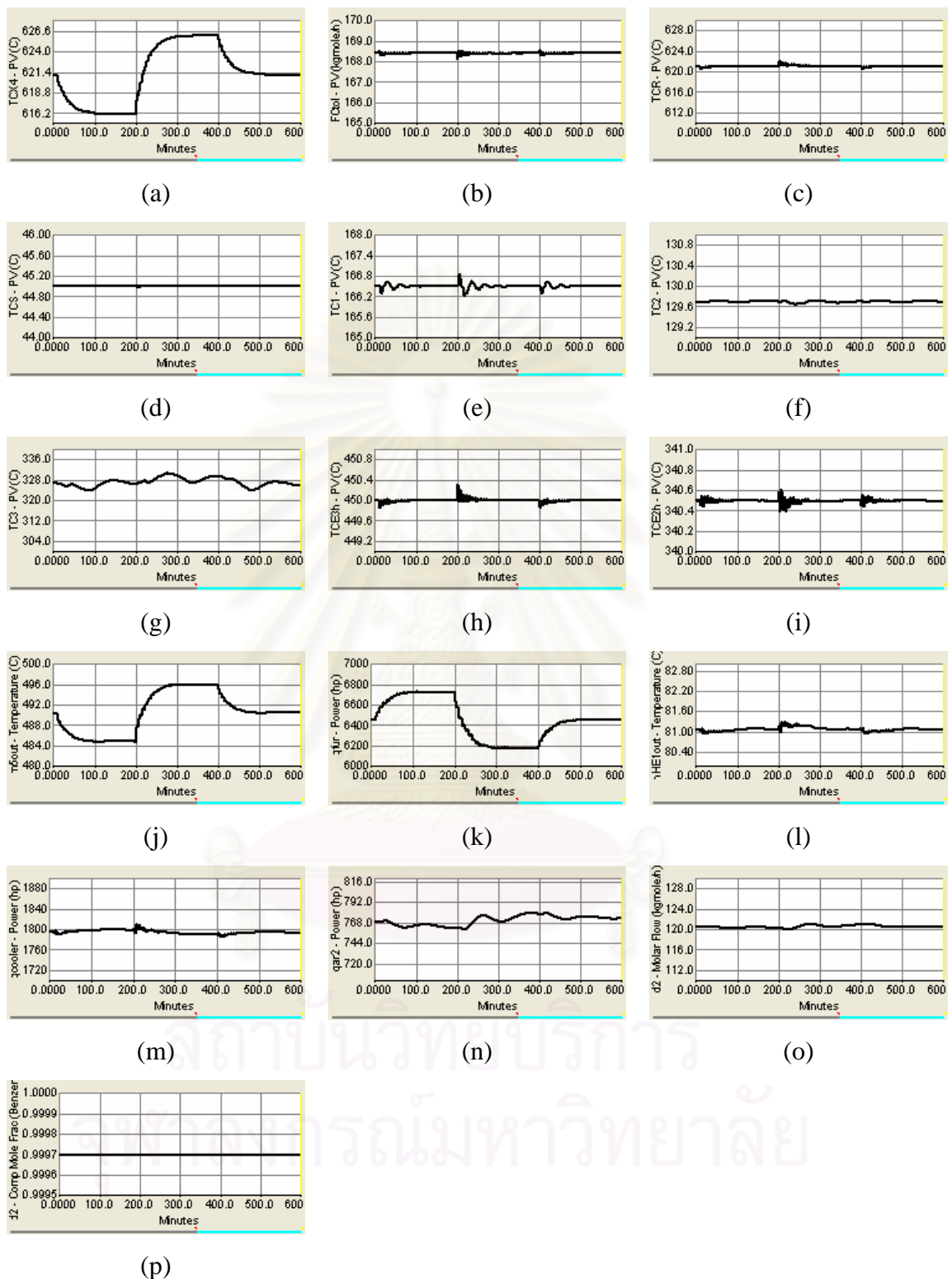

Figure 6.34: Dynamic responses of Base Case of the HDA process with minimum auxiliary reboiler to a change in the disturbance load of hot stream (reactor product)

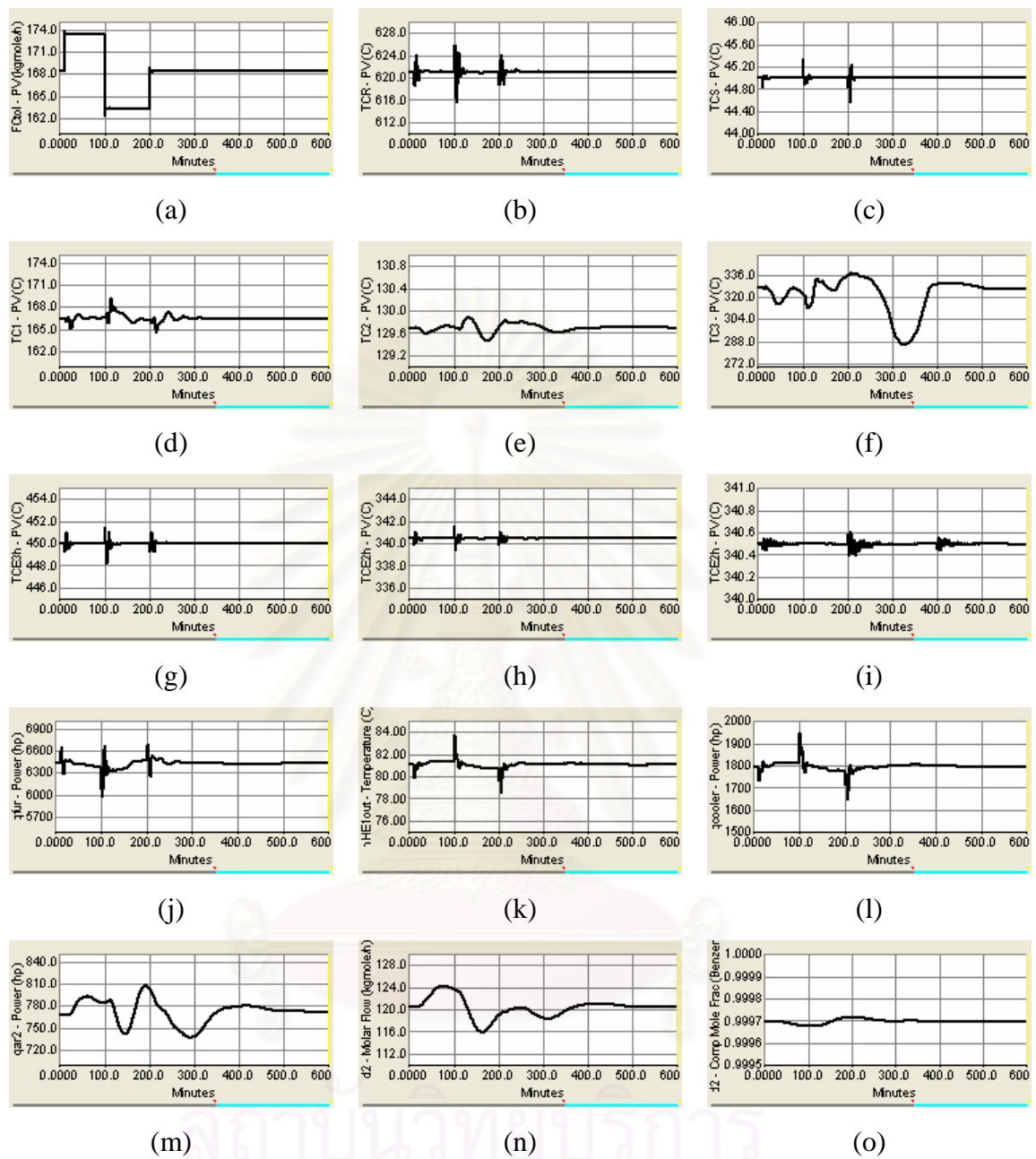

Figure 6.35: Dynamic responses of Base Case of the HDA process with minimum auxiliary reboiler to a change in the total toluene feed flowrate

are the same as those used in Base Case of the HDA process with minimum auxiliary reboilers, except for the tray temperature control in the product column.

This control structure for the HDA process with minimum auxiliary reboilers, we apply the Base Case by using a logical control concept. In this control structure both bypass valve of column heat exchanger and auxiliary reboiler duty are used to control the tray temperature of column. When bypass valve decrease to 5 percent opening but the tray temperature of the column cannot achieve its setpoint, the auxiliary reboiler duty will operate to control the tray temperature. Besides, there are two the tray temperature controllers in the stabilizer column. The initial values of all of the controlled and manipulated variables come from steady state simulation and listed in Table 6.6. The control structure and controller parameters are shown in Table C.6. In this work, the type of controller for each control loop is different. P controllers are employed for the level loops, PID controllers are employed for the temperature loops and PI controllers are employed for the remaining loops.

6.6.1 Dynamic Simulation Results for HDA Process with Minimum Auxiliary Reboilers: Control Structure 1

In order to illustrate the dynamic behavior of the control structure in HDA process Alternative 6 with minimum auxiliary reboilers (CS1), several disturbance loads are made. The dynamic responses of the control system are shown in Figures 6.37 to 6.42. Results for individual disturbance load changes are as follows:

6.6.1.1 Change in the Disturbance Load of Cold Stream (Reactor Feed Stream)

Figure 6.37 shows the dynamic responses to a change in the disturbance load of cold stream (reactor feed stream). This disturbance is made as follows: first the fresh toluene feed temperature is decreased from 30°C to 20°C at time equals 10 minutes, and the temperature is increased from 20°C to 40°C at time equals 100 minutes, then its temperature is returned to its nominal value of 30°C at time equals 200 minutes.

As can be seen, the dynamic responses of the CS1 with minimum auxiliary reboiler are better than that of the Base Case with minimum auxiliary reboiler. Particularly, the tray temperature in the recycle column and tray-6 temperature in the stabilizer column provide well controlled (Figure 6.37.e and h), since there are two tray temperature controls in the stabilizer column (One is the tray-3 temperature control and the other is tray-6 temperature control). For the other dynamic responses, they are similar to the previous control structure. The small oscillations occur in the reactor inlet temperature and the tray temperature of the stabilizer column (Figure 6.37.c and f). But the separator temperature and the tray temperature in the product column are well controlled (Figure 6.37.d and g).

6.6.1.2 Change in the Disturbance Load of Cold Stream from the Bottoms of Stabilizer Column

Figure 6.38 shows the dynamic responses of HDA process alternative 6 (CS1) to a change in the disturbance load of cold stream which originating from the bottoms of the stabilizer column, by changing its temperature from 190°C to 188°C at time equals 10 minutes, and its temperature is increased from 188°C to 192°C at time equals 200 minutes, then its temperature is returned to its nominal value of 192°C at time equals 400 minutes.

The dynamic responses of this control structure are worse than that of the Base Case with minimum auxiliary reboiler. Particularly, the tray temperature in the recycle column provides a quite poor controlled (Figure 6.38.h), since the performance of the tray temperature controlling in distillation column by auxiliary reboiler duty is better than that by the bypass valve. However, the other dynamic responses of this control structure are similar to the Base Case such as the separator temperature and the tray temperature in the product column are well controlled (Figure 6.38.d and g). The small oscillations happen in the reactor inlet temperature and the tray temperature in the stabilizer column (Figure 6.38.c, e and f).

6.6.1.3 Change in the Disturbance Load of Cold Stream from the

Bottoms of Product Column

Figure 6.39 shows the dynamic responses of HDA process to a change in the disturbance load of cold stream from the bottoms of the product column, by changing its temperature from 144°C to 142°C at time equals 10 minutes, and the its temperature is increased from 142°C to 146°C at time equals 200 minutes, then its temperature is returned to its nominal value of 144°C at time equals 400 minutes.

As can be seen, the most of dynamic responses of this control structure are similar to the previous control structure (i.e. the separator temperature is well controlled (Figure 6.39.d), the oscillations occur in the reactor inlet temperature and the tray temperature of the stabilizer column (Figure 6.39.c, e and f).). But the tray temperature in the recycle column has a large deviation about 28°C and it takes long time to return to its nominal value (Figure 6.39.h), since the performance of the tray temperature controlling in distillation column by auxiliary reboiler duty is better than that by the bypass valve. Thus the overall performance of this control structure is worse than that of the Base Case.

6.6.1.4 Change in the Disturbance Load of Cold Stream from the Bottoms of Recycle Column

Figure 6.40 shows the dynamic responses of HDA process alternative 6 (CS1) to a change in the disturbance load of cold stream from the bottoms of the recycle column, by changing its temperature from 349.8°C to 347.8°C at time equals 10 minutes, and the its temperature is increased from 347.8°C to 351.8°C at time equals 300 minutes, then its temperature is returned to its nominal value of 349.8°C at time equals 600 minutes.

The dynamic responses of CS1 are worse than that of the Base Case with minimum auxiliary reboiler when the change in the disturbance loads of the cold stream from the bottoms of the recycle column occurs. Particularly, the tray temperature control in recycle column provides a quite poor performance (Figure 6.40.h), since the performance of the tray temperature controlling in distillation

column by auxiliary reboiler duty is better than that by the bypass valve. However, the other dynamic responses of this control structure are not different from the dynamic responses of the Base Case such as the separator temperature, the reactor inlet temperature, the tray temperature in the stabilizer and product column. For the tray temperature in the recycle column, it has a large deviation about 10°C and it takes more than 700 minutes to return to its nominal value of 326.7°C .

6.6.1.5 Change in the Disturbance Load of Hot Stream (Reactor Product)

Figure 6.41 shows the dynamic responses of HDA process to a change in the disturbance load of hot stream from reactor, by changing its temperature from 621.11°C to 616.11°C at time equals 10 minutes, and the its temperature is increased from 616.11°C to 626.11°C at time equals 200 minutes, then its temperature is returned to its nominal value of 621.11°C at time equals 400 minutes.

As can be seen, the most dynamic responses of the CS1 are similar to the previous control structure (i.e. the separator temperature and the reactor inlet temperature are well controlled (Figure 6.41.c and d), the oscillations occur in the tray temperature of the stabilizer and product column (Figure 6.41. e, f and g).). Its advantage is that it provides higher performance of the tray temperature control in the recycle column and tray-6 temperature control, since there are two tray temperature controls in the stabilizer column (One is the tray-3 temperature control and the other is tray-6 temperature control). The tray temperature in the recycle column has a small oscillation and it takes more than 500 minutes to die out (Figure 6.41.h).

6.6.1.6 Change in the Total Toluene Feed Flowrate

Figure 6.42 shows the dynamic responses of HDA process to a change in the total toluene feed flowrates from 168.4 kgmole/hr to 173.4 kgmole/hr at time equals 10 minutes, and the its feed flowrate is decreased from 173.4 kgmole/hr to

163.4 kgmole/hr at time equals 100 minutes, then its flowrates is returned to its nominal value of 168.4 kgmole/hr at time equals 200 minutes.

The dynamic responses of this control structure are better than that of the Base Case with minimum auxiliary reboiler. As can be seen, the separator temperature is quite well controlled (Figure 6.42.c). A small oscillation of 2°C happens in the tray-3 temperature of the stabilizer column (Figure 6.42.e) but a slightly well controlled occurs in the tray temperature of the product column (Figure 6.42.f). The tray temperature in the recycle column has a large deviation about 40°C and it takes over 500 minutes to return to its nominal value (Figure 6.42.g).

6.7 Design of plantwide Control for HDA Process with Minimum Auxiliary Reboilers: Control Structure 2

The new plantwide control structure for energy-integrated HDA process with minimum auxiliary reboilers (CS2) is shown in Figure 6.43. Its major loops are the same as those used in Base Case of the HDA process with minimum auxiliary reboilers, except for the tray temperature control in the recycle column, the feed flowrate control in the recycle column and the level control of Drum 2 in the product column.

This control structure for the HDA process with minimum auxiliary reboilers, we apply the CS1 by changing the manipulated variable of the column C2 base level control from the feed flowrate of recycle column to the cold inlet flowrate of R2 and the feed flowrate of recycle column is flow-controlled for to reduce the material and flow fluctuation before propagate to the recycle column when the disturbance occurs. The initial values of all of the controlled and manipulated variables come from steady state simulation and listed in Table 6.7. The control structure and controller parameters are shown in Table C.7. In this work, the type of controller for each control loop is different. P controllers are employed

Table 6.6 The initial values of controlled and manipulated variables for HDA process with minimum auxiliary reboilers: Control Structure 1

Controlled variable		Manipulated variable	
Process variable	Initial value	Process variable	Initial value
total toluene flowrate	168.4 kgmole/hr	fresh toluene feed flowrate	128.9 kgmole/hr
gas recycle stream pressure	605 psia	fresh hydrogen feed flowrate	220.5 kgmole/hr
methane in gas recycle	0.5877 mole-frac	purge flowrate	217.5 kgmole/hr
quenched temperature	621.1 °C	quench flowrate	48.5 kgmole/hr
reactor inlet temperature	621.1 °C	furnace duty	4796 kW
separator temperature	45 °C	cooler duty	1339 kW
hot outlet temperature of FEHE 2	340.5 °C	bypass flowrate of FEHE 2	266.7 kgmole/hr
hot outlet temperature of FEHE 3	450 °C	bypass flowrate of FEHE 3	180.9 kgmole/hr
separator liquid level	50 %-level	column C1 feed flowrate	171.3 kgmole/hr
column C1 pressure	150 psia	column C1 gas flowrate	8.677 kgmole/hr
column C1 tray-3 temperature	177.3 °C	bypass flowrate of R1	486.6 kgmole/hr
column C1 tray-6 temperature	166.5 °C	column C1 reflux flowrate	32.67 kgmole/hr
column C1 base level	50 %-level	column C2 feed flowrate	162.7 kgmole/hr
column C1 reflux drum level	50 %-level	column C1 condenser duty	370.2 kW
column C1 boil-up flowrate	183 kgmole/hr	cold inlet flowrate of R1	183 kgmole/hr
column C2 pressure	30 psia	column C2 condenser duty	5016 kW
column C2 tray-12 temperature	129.7 °C	bypass flowrate of R2	152.2 kgmole/hr
		auxiliary reboiler 2 (R2) duty	573.5 kW
column C2 base level	50 %-level	column C3 feed flowrate	42.16 kgmole/hr
column C2 reflux drum level	50 %-level	column C2 product flowrate	120.5 kgmole/hr
column C2 boil-up flowrate	385 kgmole/hr	cold inlet flowrate of R2	385 kgmole/hr
column C3 pressure	76.32 psia	bypass flowrate of CR	26.32 kgmole/hr
avg C3-tray 1, 2, 3, and 4 temperature	326.7 °C	bypass flowrate of R3	177.3 kgmole/hr
column C3 base level	50 %-level	column C3 bottom flowrate	2.644 kgmole/hr
column C3 reflux drum level	50 %-level	toluene recycle flowrate	39.52 kgmole/hr
column C3 boil-up flowrate	47.26 kgmole/hr	cold inlet flowrate of R3	47.26 kgmole/hr
column C3 reflux flowrate	9.94 kgmole/hr	column C3 reflux flowrate	9.94 kgmole/hr

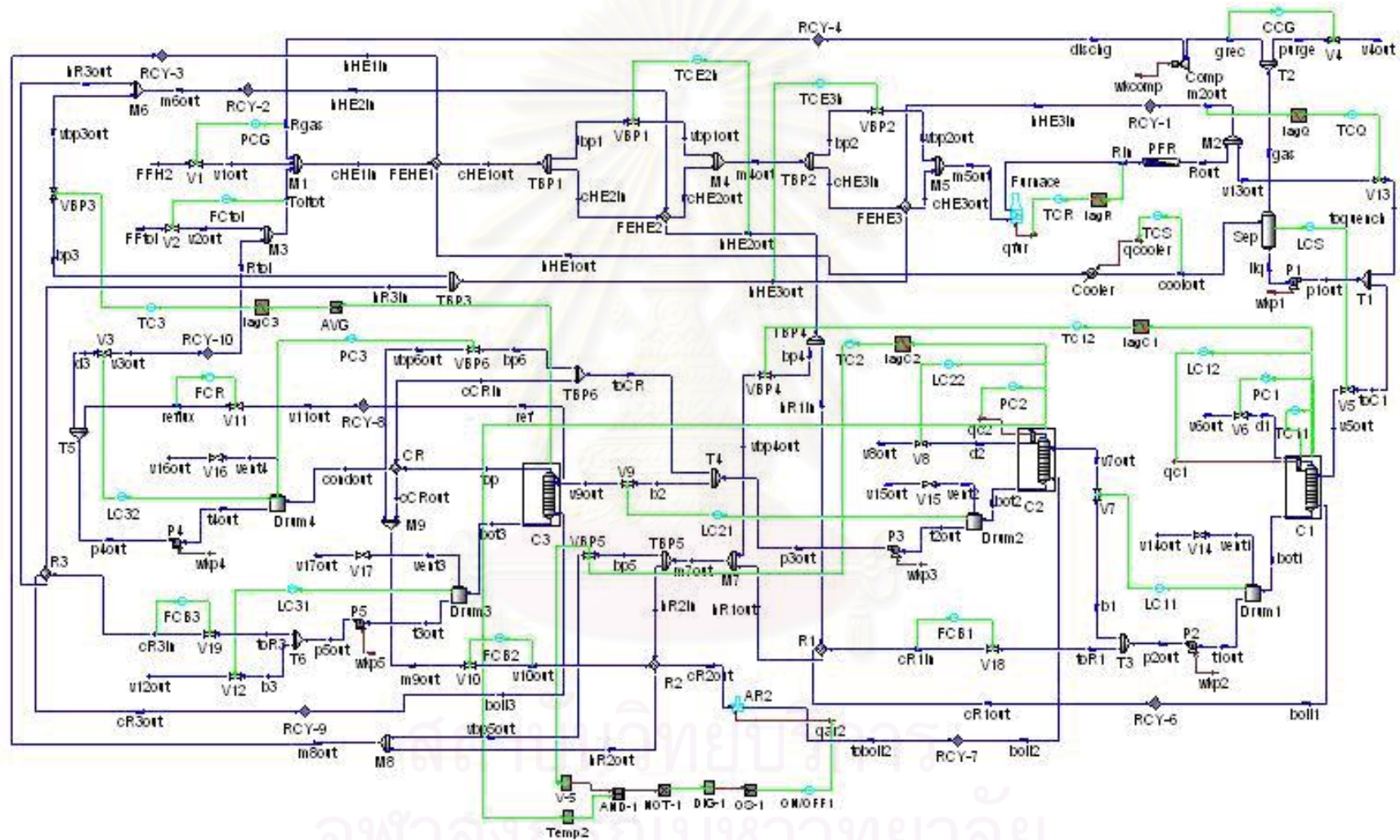

Figure 6.36: Control structures 1 of the HDA process with minimum auxiliary reboilers

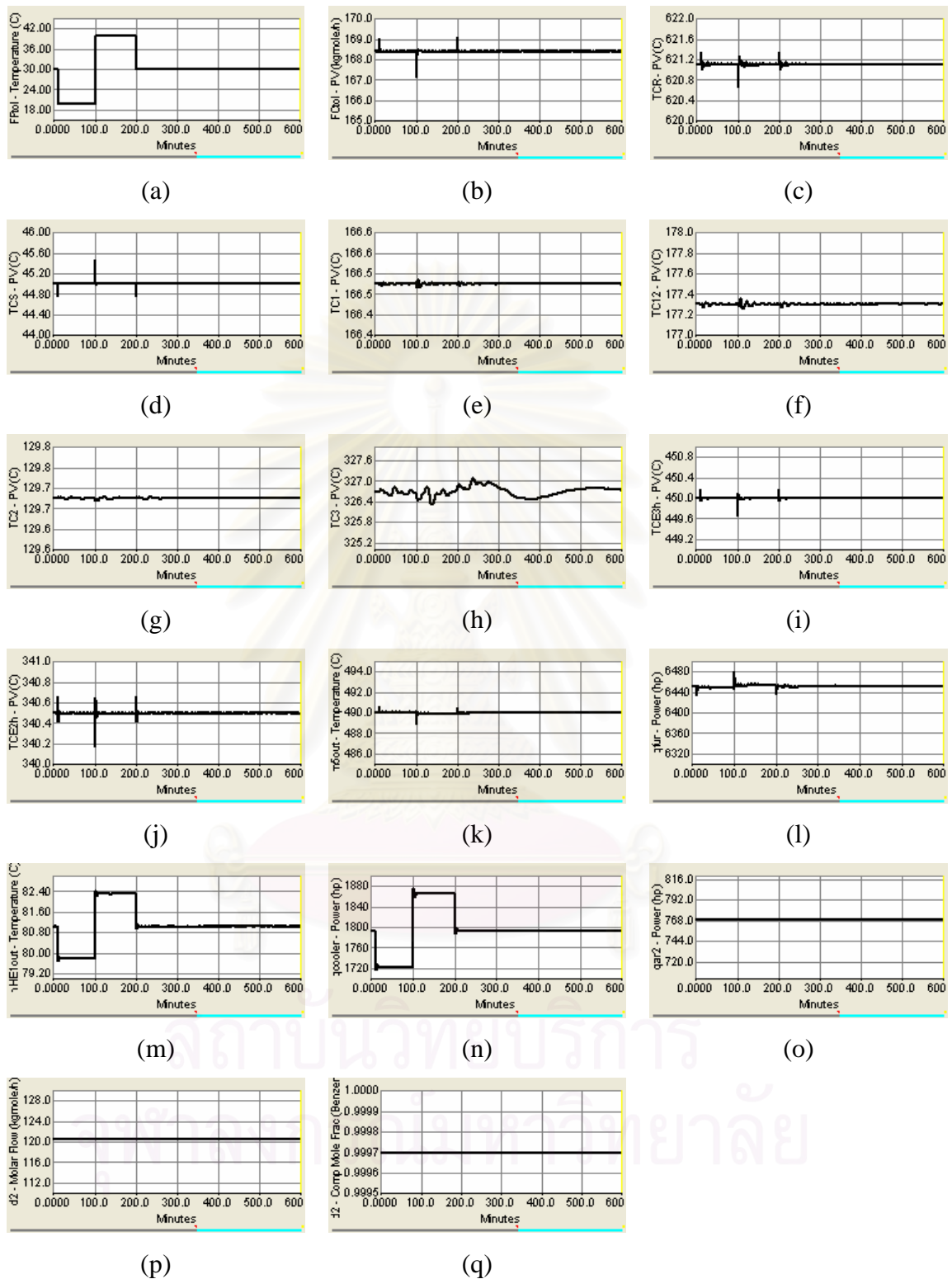

Figure 6.37: Dynamic responses of CS1 of the HDA process with minimum auxiliary reboiler to a change in the disturbance load of cold stream (reactor feed stream)

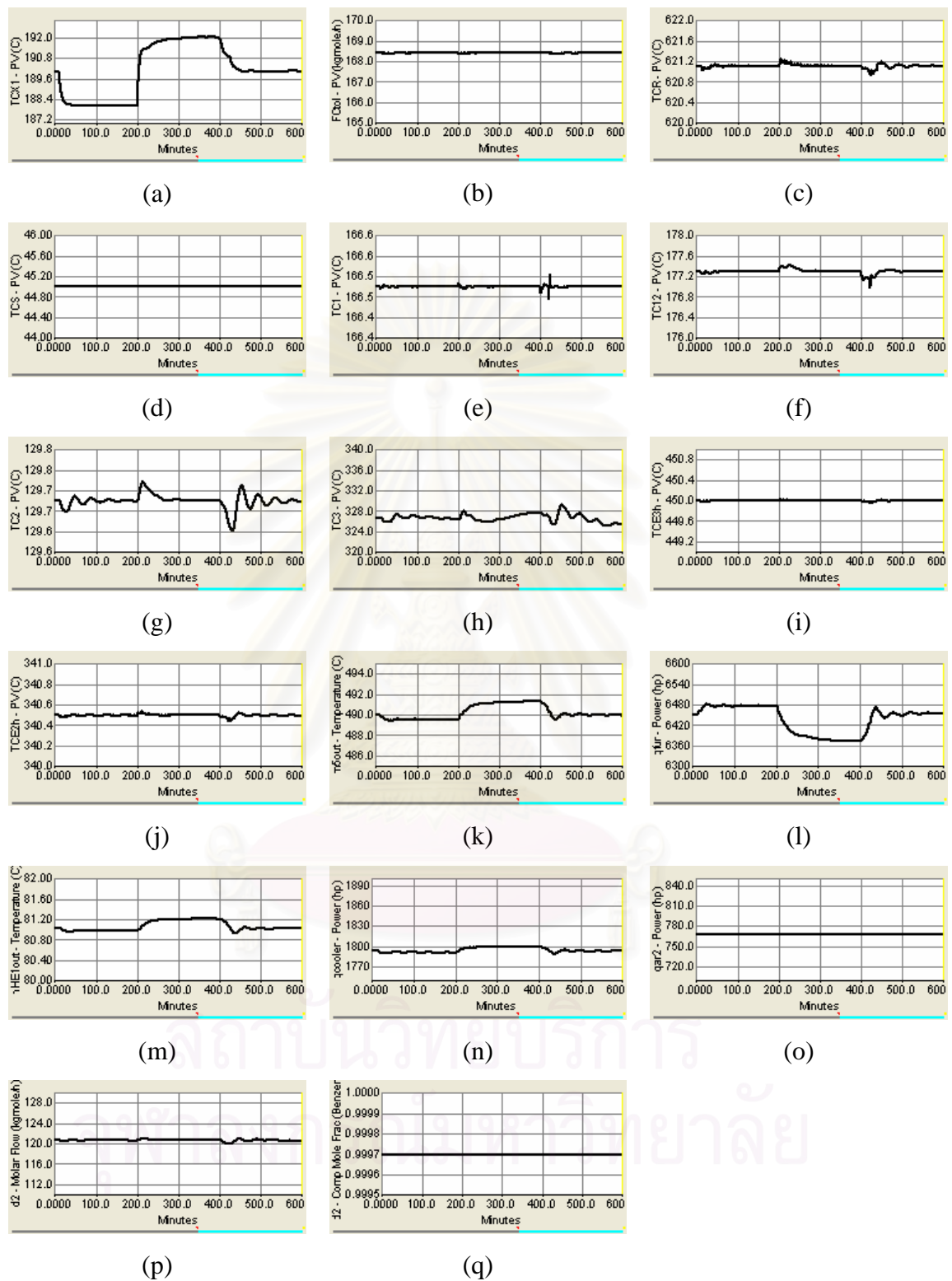

Figure 6.38: Dynamic responses of CS1 of the HDA process with minimum auxiliary reboiler to a change in the disturbance load of cold stream from the bottom of the stabilizer column

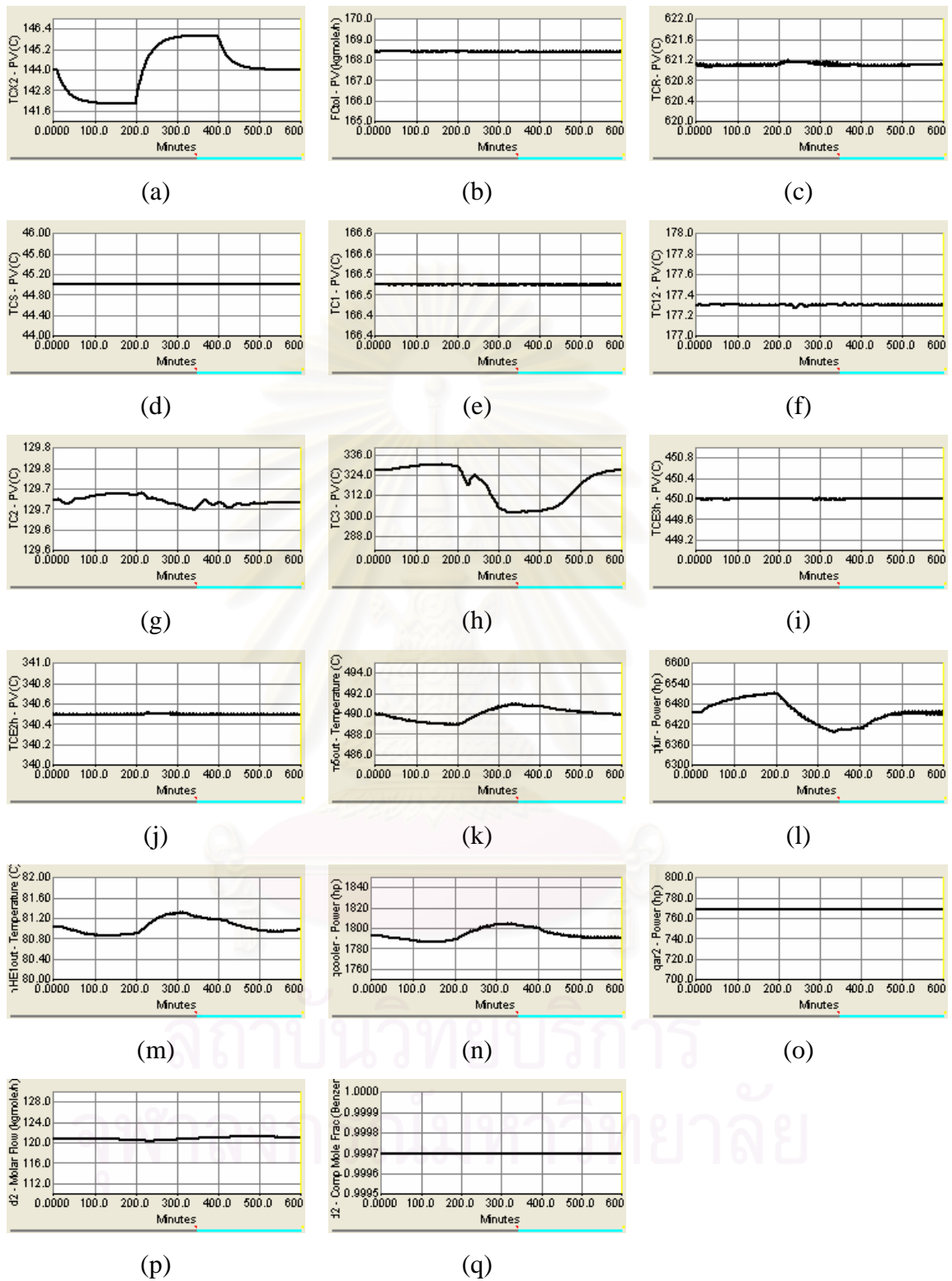

Figure 6.39: Dynamic responses of CS1 of the HDA process with minimum auxiliary reboiler to a change in the disturbance load of cold stream from the bottom of the product column

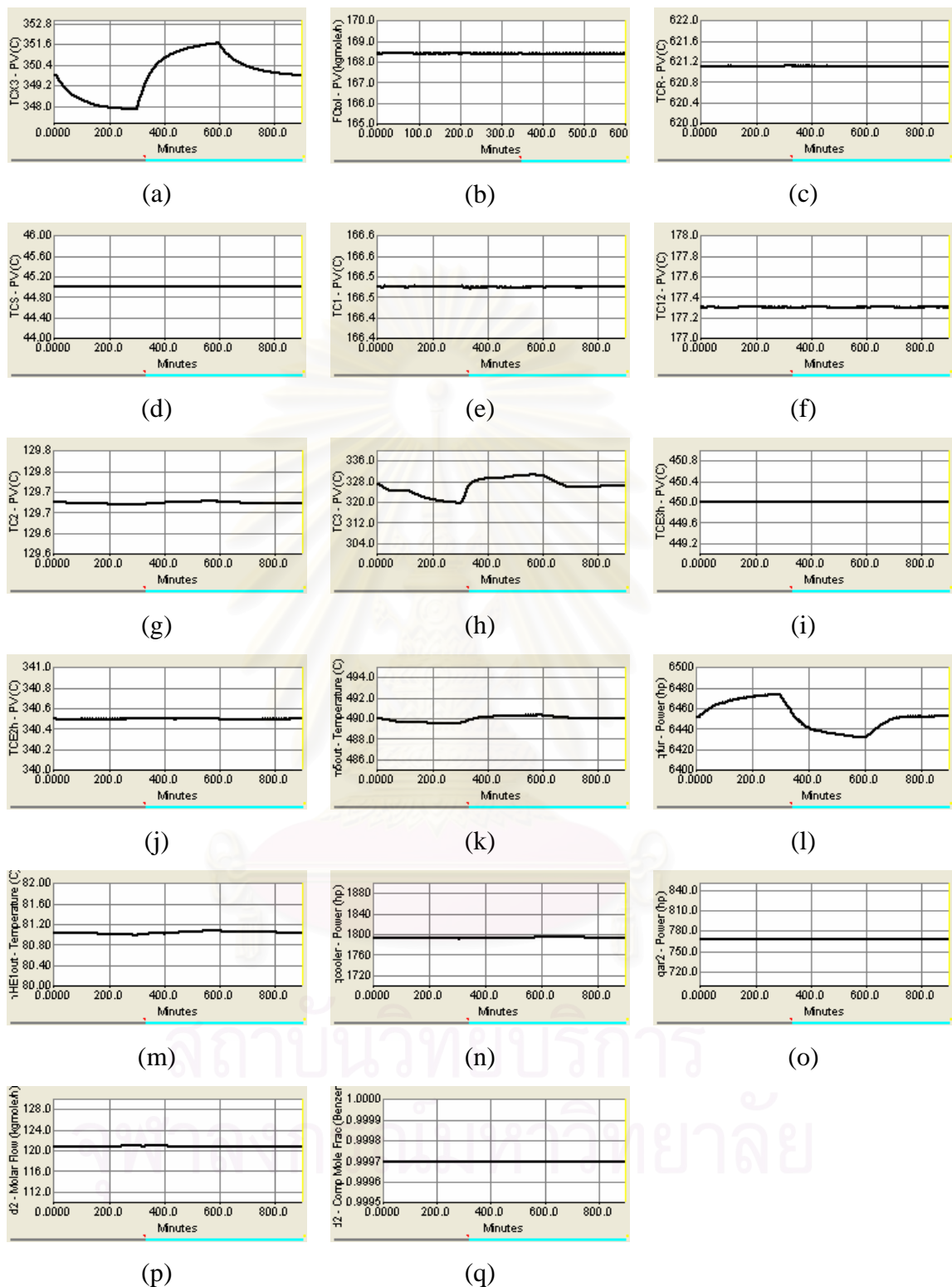

Figure 6.40: Dynamic responses of CS1 of the HDA process with minimum auxiliary reboiler to a change in the disturbance load of cold stream from the bottom of the recycle column

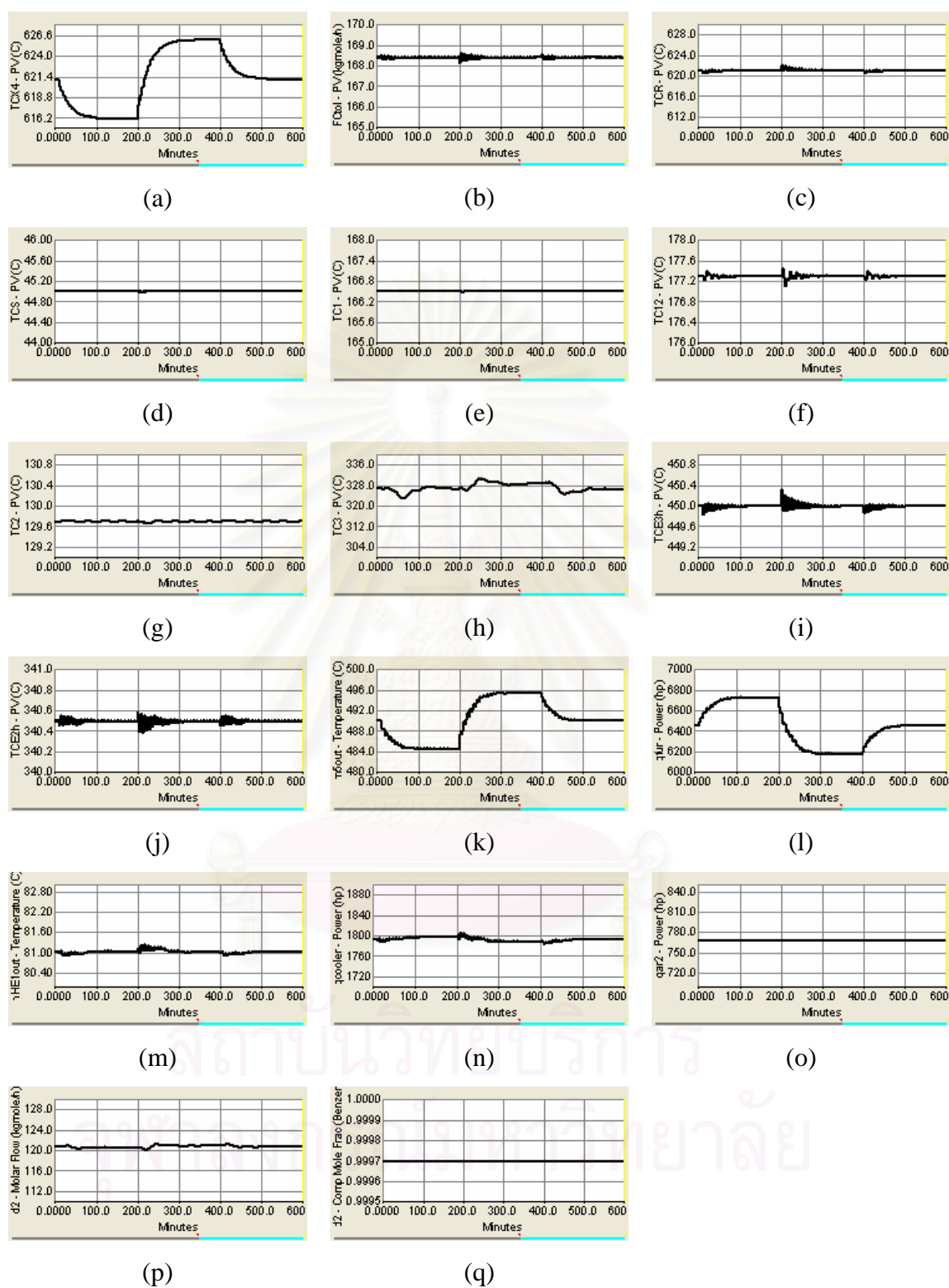

Figure 6.41: Dynamic responses of CS1 of the HDA process with minimum auxiliary reboiler to a change in the disturbance load of hot stream (reactor product)

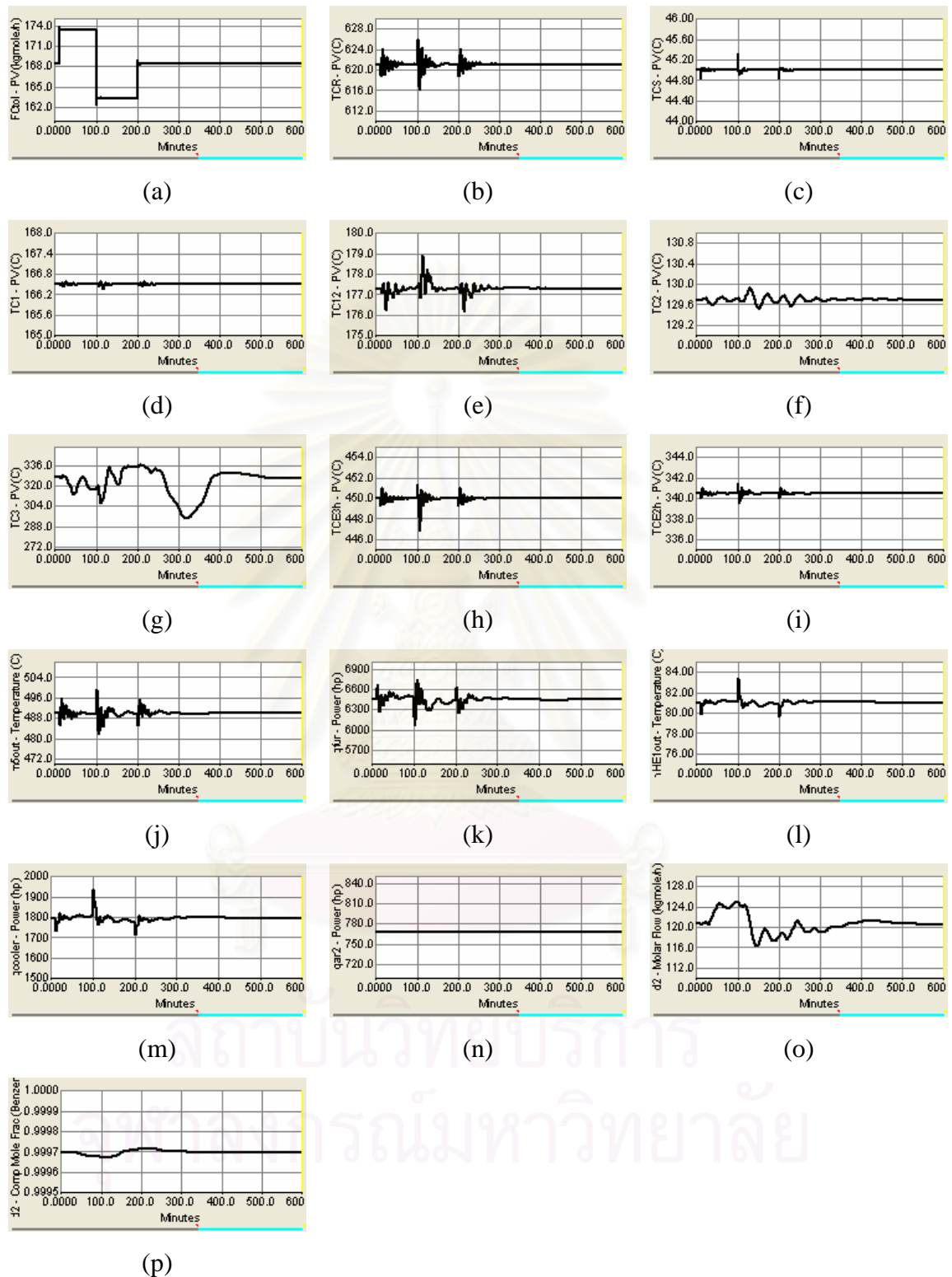

Figure 6.42: Dynamic responses of CS1 of the HDA process with minimum auxiliary reboiler to a change in the total toluene feed flowrate

for the level loops, PID controllers are employed for the temperature loops and PI controllers are employed for the remaining loops.

6.7.1 Dynamic Simulation Results for HDA Process with Minimum Auxiliary Reboilers: Control Structure 2

In order to illustrate the dynamic behavior of the control structure in HDA process Alternative 6 with minimum auxiliary reboilers (CS2), several disturbance loads are made. The dynamic responses of the control system are shown in Figures 6.44 to 6.49. Results for individual disturbance load changes are as follows:

6.7.1.1 Change in the Disturbance Load of Cold Stream (Reactor Feed Stream)

Figure 6.44 shows the dynamic responses to a change in the disturbance load of cold stream (reactor feed stream). This disturbance is made as follows: first the fresh toluene feed temperature is decreased from 30°C to 20°C at time equals 10 minutes, and the temperature is increased from 20°C to 40°C at time equals 100 minutes, then its temperature is returned to its nominal value of 30°C at time equals 200 minutes.

The dynamic responses of this control structure are the best of all control structure with minimum auxiliary reboiler because the feed flowrate of the recycle column is flow-controlled. As the flow fluctuation happens in the stabilizer column, the effect of this change will not propagate to the recycle column or downstream unit operations. As can be seen, the tray temperature in the recycle column provides a well controlled (Figure 6.44.h). However, the dynamic responses of this control structure do not different from the dynamic responses of the Base Case when the same disturbance occurs.

The separator temperature and the tray temperature in the product column are well controlled (Figure 6.44.d and g) but the small oscillations occur in the reactor inlet temperature and the tray temperature of the stabilizer and recycle column (Figure 6.44.c, e and f).

6.7.1.2 Change in the Disturbance Load of Cold Stream from the Bottoms of Stabilizer Column

Figure 6.45 shows the dynamic responses of HDA process alternative 6 (CS2) to a change in the disturbance load of cold stream which originating from the bottoms of the stabilizer column, by changing its temperature from 190°C to 188°C at time equals 10 minutes, and its temperature is increased from 188°C to 192°C at time equals 200 minutes, then its temperature is returned to its nominal value of 190°C at time equals 400 minutes.

The dynamic responses of the CS2 with minimum auxiliary reboiler is the best of all control structure with minimum auxiliary reboiler when the change in the disturbance load of cold stream from the bottoms of the stabilizer column happens because the feed flowrate of the recycle column is flow-controlled. As a result, the effect of this change is reduced before it enters to the recycle column. Particularly, the tray temperature in the recycle column provides a well controlled (Figure 6.45.h). For the other dynamic responses, they are similar to dynamic responses of Base Case.

6.7.1.3 Change in the Disturbance Load of Cold Stream from the Bottoms of Product Column

Figure 6.46 shows the dynamic responses of HDA process to a change in the disturbance load of cold stream from the bottoms of the product column, by changing its temperature from 144°C to 142°C at time equals 10 minutes, and the its temperature is increased from 142°C to 146°C at time equals 200 minutes, then its temperature is returned to its nominal value of 144°C at time equals 400 minutes.

As can be seen, this is the best control structure for to handle a change in the disturbance load of cold stream from the bottom of product column. In this control structure, the feed flowrate of the recycle column is flow-controlled, so the effect of this change is reduced before entering to the recycle column. As a result, it provides the highest performance of the tray temperature in the recycle column

(Figure 6.46.h). However, the most dynamic responses of this control structure are similar to the previous control structure (i.e. the separator temperature and the tray temperature in the product column are well controlled (Figure 6.46.d and g), the oscillations occur in the reactor inlet temperature and the tray temperature of the stabilizer column (Figure 6.46.c, e and f).).

6.7.1.4 Change in the Disturbance Load of Cold Stream from the Bottoms of Recycle Column

Figure 6.47 shows the dynamic responses of HDA process alternative 6 (CS1) to a change in the disturbance load of cold stream from the bottoms of the product column, by changing its temperature from 349.8°C to 347.8°C at time equals 10 minutes, and the its temperature is increased from 347.8°C to 351.8°C at time equals 300 minutes, then its temperature is returned to its nominal value of 349.8°C at time equals 600 minutes.

The dynamic responses of the CS2 with minimum auxiliary reboiler are the best of all control structures with minimum auxiliary reboiler as the change in the disturbance loads of the cold stream from the bottoms of the recycle column happens. In this control structure, the manipulated variable of the base level control in the product column is changed from the feed flowrate of recycle column to the cold inlet flowrate of R2 and the feed flowrate of recycle column is flow-controlled. As a result, the effect of disturbance is reduced before entering to the recycle column. Then, the performance of the tray temperature control in the recycle column is the best (i.e. the tray temperature in the recycle column has a deviation of 6°C and it takes more than 700 minutes to return to its nominal value of 326.7°C (Figure 6.47.h).). However, the other dynamic responses are similar to the above control structures with minimum auxiliary reboiler as the same disturbance occurs such as the separator temperature, the reactor inlet temperature and the tray temperature in the stabilizer column (Figure 6.47.c, d, e and f).

6.7.1.5 Change in the Disturbance Load of Hot Stream (Reactor Product)

Figure 6.48 shows the dynamic responses of HDA process to a change in the disturbance load of hot stream from reactor, by changing its temperature from 621.11°C to 616.11°C at time equals 10 minutes, and the its temperature is increased from 616.11°C to 626.11°C at time equals 200 minutes, then its temperature is returned to its nominal value of 621.11°C at time equals 400 minutes.

This is the best control structure for to handle a change in the disturbance load of hot stream. Since, the feed flowrate of the recycle column is flow-controlled. As a result, the effect of this change does not propagate to the downstream unit operation (recycle column). However, the other dynamic responses of this control structure are similar to the other control structure with minimum auxiliary reboiler (i.e. the separator temperature, the reactor inlet temperature and the tray temperature in the product column are quite well controlled (Figure 6.48.c, d and g), the oscillation happens in the tray temperature of the stabilizer column (Figure 6.48.e and f).). A small deviation of 2°C occurs in the tray temperature of the recycle column and it takes over 450 minutes to return to its nominal value (Figure 6.48.h).

6.7.1.6 Change in the Total Toluene Feed Flowrate

Figure 6.49 shows the dynamic responses of HDA process to a change in the total toluene feed flowrates from 168.4 kgmole/hr to 173.4 kgmole/hr at time equals 10 minutes, and the its feed flowrate is decreased from 173.4 kgmole/hr to 163.4 kgmole/hr at time equals 100 minutes, then its flowrates is returned to its nominal value of 168.4 kgmole/hr at time equals 200 minutes.

The dynamic responses of the CS2 with minimum auxiliary reboiler are the best of all control structures with minimum auxiliary reboiler when the change in total toluene feed flowrate occurs. Particularly, the tray temperature in the stabilizer and recycle column provide the best controlled (Figure 6.49.d,e and g) because the feed flowrate of the recycle column is flow-controlled, so the effect of this change is reduced before entering to the recycle column.

For the other dynamic responses of this control structure, they are similar to the earlier control structures. The separator temperature and the tray temperature in the product column are well controlled (Figure 6.49.c and f). Small oscillations occur in the tray temperature of the stabilizer column and a large deviation of 10°C happens in the tray temperature of the recycle column and it takes more than 300 minutes to return to its nominal value of 326.7°C. In addition, the oscillations occur in the reactor inlet temperature (Figure 6.49.b).

6.8 Design of plantwide Control for HDA Process with Minimum Auxiliary Reboilers: Control Structure 3

The new plantwide control structure for energy-integrated HDA process with minimum auxiliary reboilers (CS3) is shown in Figure 6.50. Its major loops are the same as those used in the Base Case of the HDA process with minimum auxiliary reboilers, except for the tray temperature control in the recycle column, the feed flowrate control in the recycle column, the level control of Drum 2 in the product column, the column C1 pressure control, the column C1 reflux drum level control and the tray-6 temperature control in column C1.

The last control structure for the HDA process with minimum auxiliary reboilers, we apply the CS2 by changing the manipulated variable of the column C1 pressure control, the column C1 reflux drum level control and the tray-6 temperature control in column C1 from the column C1 gas flowrate, the column C1 condenser duty and the column C1 reflux rate to the column C1 condenser duty, the column C1 reflux rate and the column C1 gas flowrate, respectively. The initial values of all of the controlled and manipulated variables come from steady state simulation and listed in Table 6.8. The control structure and controller parameters are shown in Table C.8. In this work, the type of controller for each control loop is different. P controllers are employed for the level loops, PID controllers are employed for the temperature loops and PI controllers are employed

Table 6.7 The initial values of controlled and manipulated variables for HDA process with minimum auxiliary reboilers: Control Structure 2

Controlled variable		Manipulated variable	
Process variable	Initial value	Process variable	Initial value
total toluene flowrate	168.4 kgmole/hr	fresh toluene feed flowrate	128.9 kgmole/hr
gas recycle stream pressure	605 psia	fresh hydrogen feed flowrate	220.5 kgmole/hr
methane in gas recycle	0.5877 mole-frac	purge flowrate	217.5 kgmole/hr
quenched temperature	621.1 °C	quench flowrate	48.5 kgmole/hr
reactor inlet temperature	621.1 °C	furnace duty	4796 kW
separator temperature	45 °C	cooler duty	1339 kW
hot outlet temperature of FEHE 2	340.5 °C	bypass flowrate of FEHE 2	266.7 kgmole/hr
hot outlet temperature of FEHE 3	450 °C	bypass flowrate of FEHE 3	180.9 kgmole/hr
separator liquid level	50 %-level	column C1 feed flowrate	171.3 kgmole/hr
column C1 pressure	150 psia	column C1 gas flowrate	8.677 kgmole/hr
column C1 tray-3 temperature	177.3 °C	bypass flowrate of R1	486.6 kgmole/hr
column C1 tray-6 temperature	166.5 °C	column C1 reflux flowrate	32.67 kgmole/hr
column C1 base level	50 %-level	column C2 feed flowrate	162.7 kgmole/hr
column C1 reflux drum level	50 %-level	column C1 condenser duty	370.2 kW
column C1 boil-up flowrate	183 kgmole/hr	cold inlet flowrate of R1	183 kgmole/hr
column C2 pressure	30 psia	column C2 condenser duty	5016 kW
column C2 tray-12 temperature	129.7 °C	bypass flowrate of R2	152.2 kgmole/hr
		auxiliary reboiler 2 (R2) duty	573.5 kW
column C2 base level	50 %-level	cold inlet flowrate of R2	387 kgmole/hr
column C2 reflux drum level	50 %-level	column C2 product flowrate	120.5 kgmole/hr
column C3 feed flowrate	42.15 kgmole/hr	column C3 feed flowrate	42.15 kgmole/hr
column C3 pressure	76.32 psia	bypass flowrate of CR	26.32 kgmole/hr
avg C3-tray 1, 2, 3, and 4 temperature	326.7 °C	bypass flowrate of R3	177.3 kgmole/hr
column C3 base level	50 %-level	column C3 bottom flowrate	2.644 kgmole/hr
column C3 reflux drum level	50 %-level	toluene recycle flowrate	39.52 kgmole/hr
column C3 boil-up flowrate	47.26 kgmole/hr	cold inlet flowrate of R3	47.26 kgmole/hr
column C3 reflux flowrate	9.94 kgmole/hr	column C3 reflux flowrate	9.94 kgmole/hr

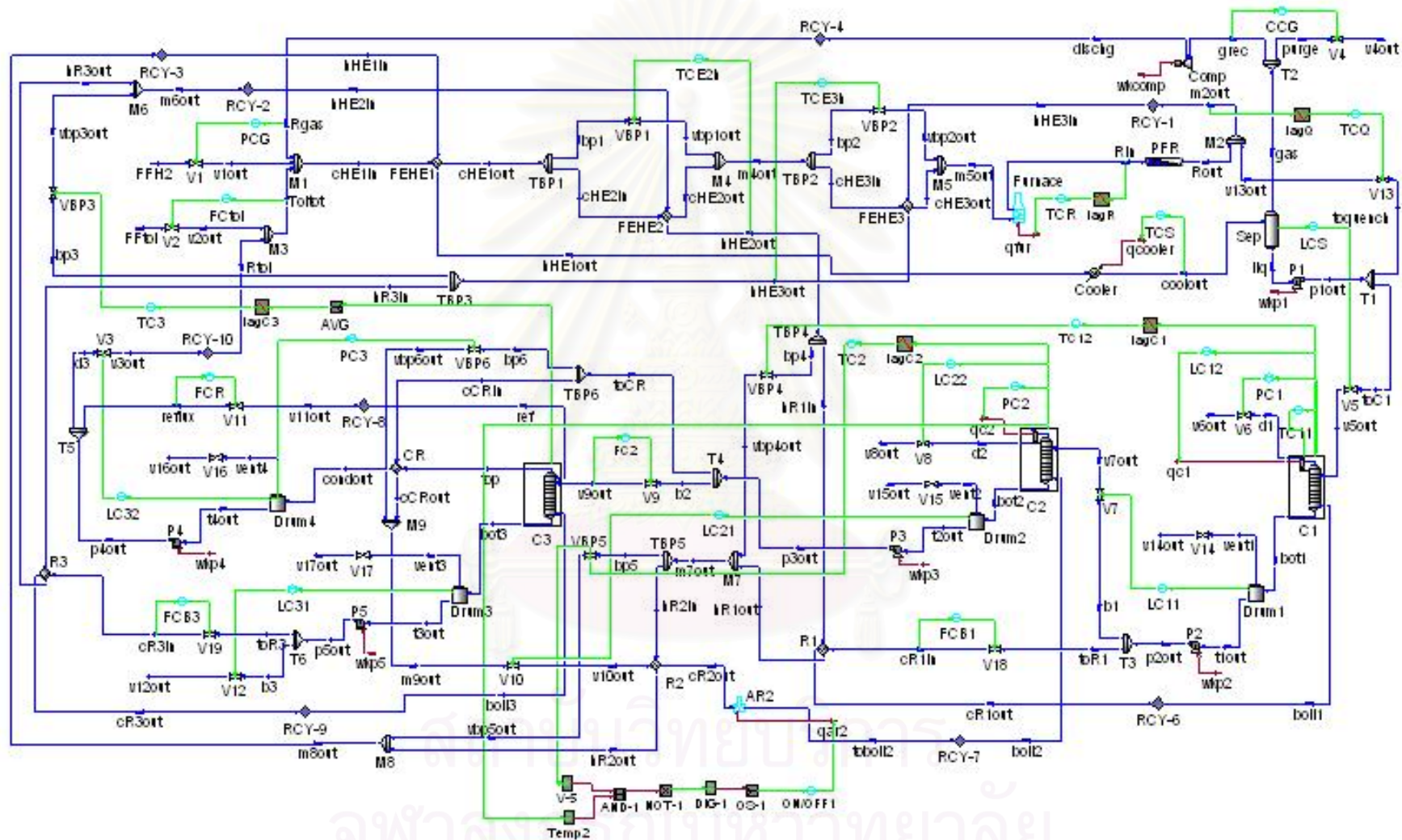

Figure 6.43: Control structures 2 of the HDA process with minimum auxiliary reboilers

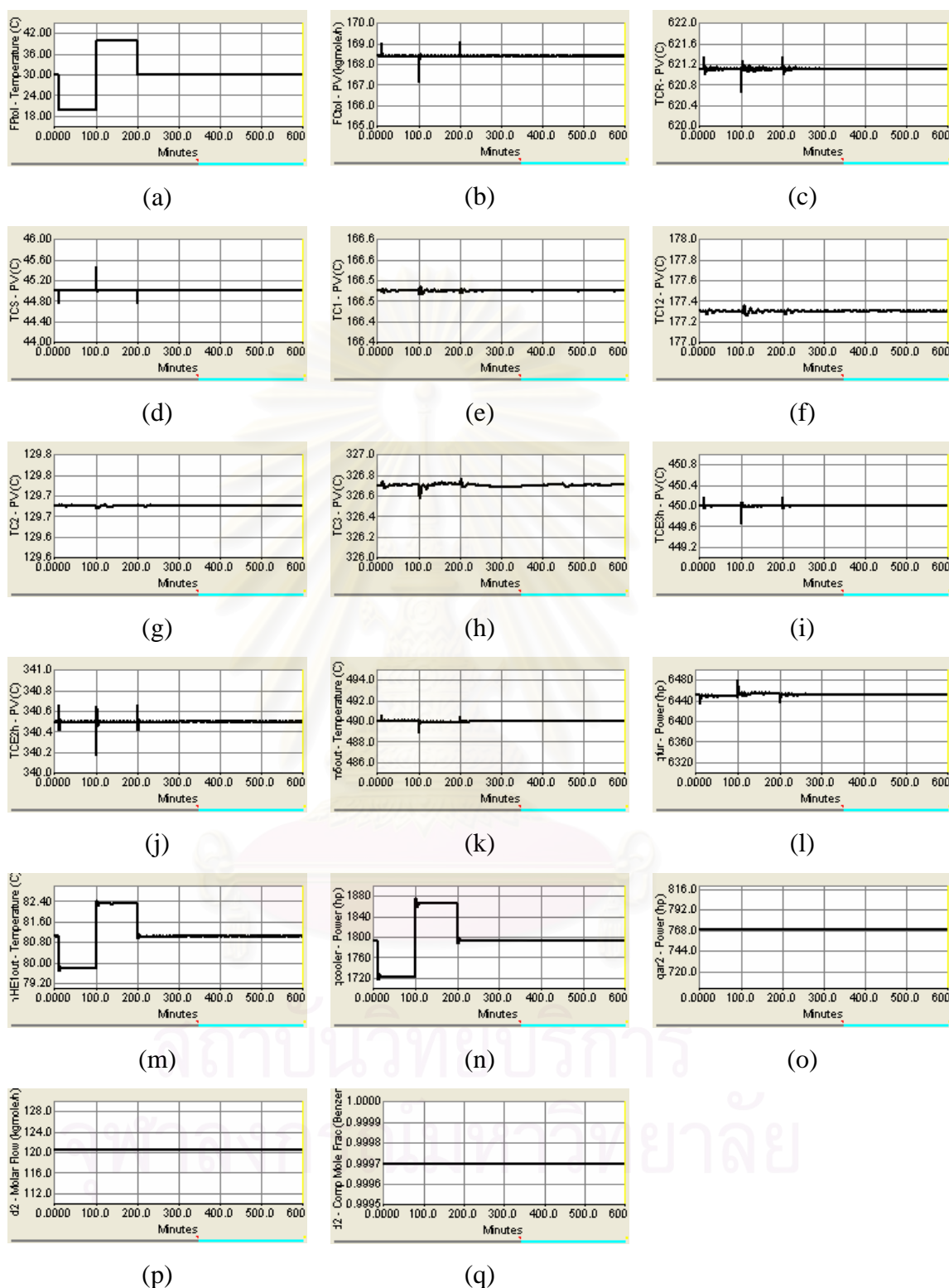

Figure 6.44: Dynamic responses of CS2 of the HDA process with minimum auxiliary reboiler to a change in the disturbance load of cold stream (reactor feed stream)

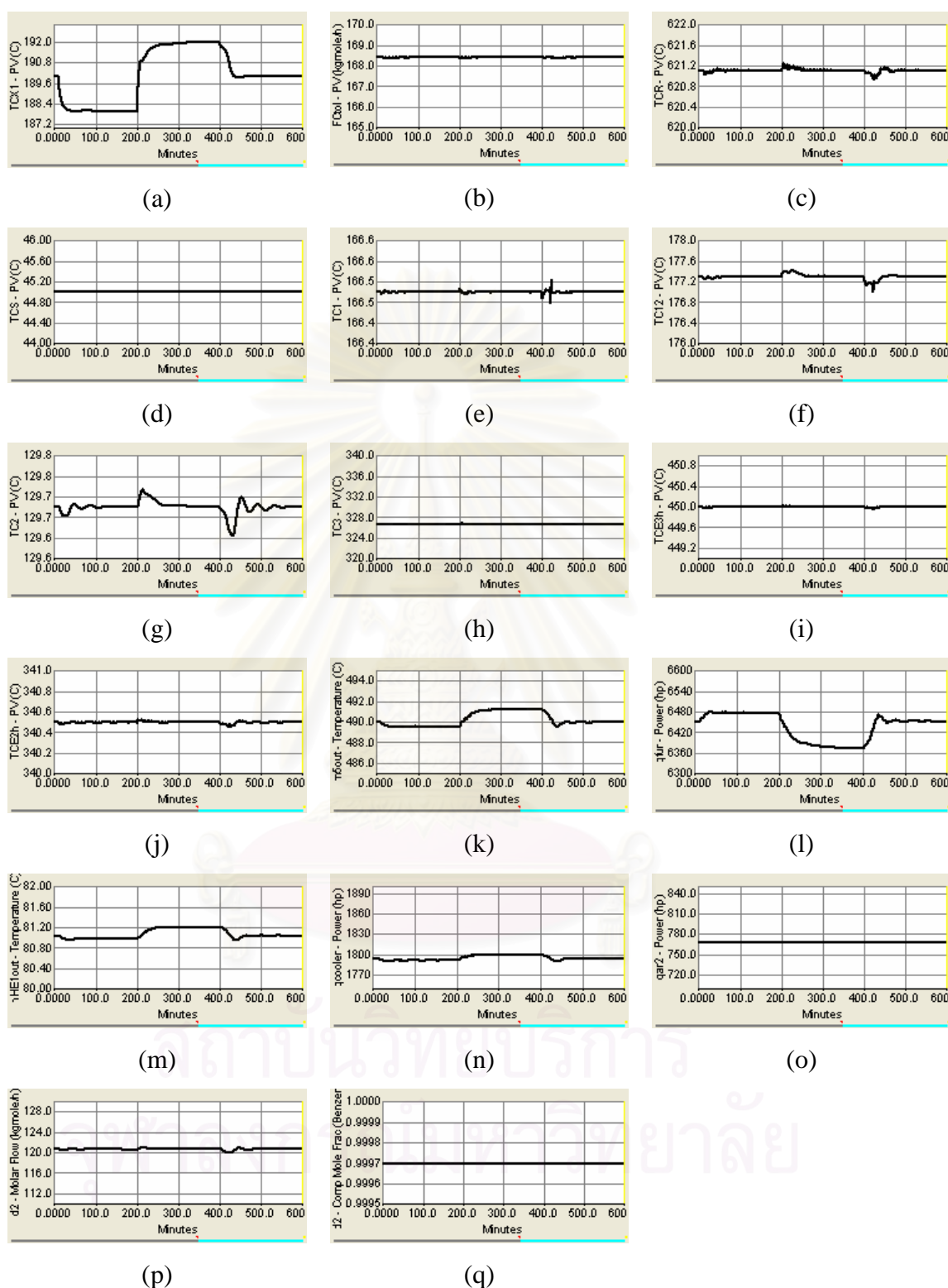

Figure 6.45: Dynamic responses of CS2 of the HDA process with minimum auxiliary reboiler to a change in the disturbance load of cold stream from the bottom of the stabilizer column

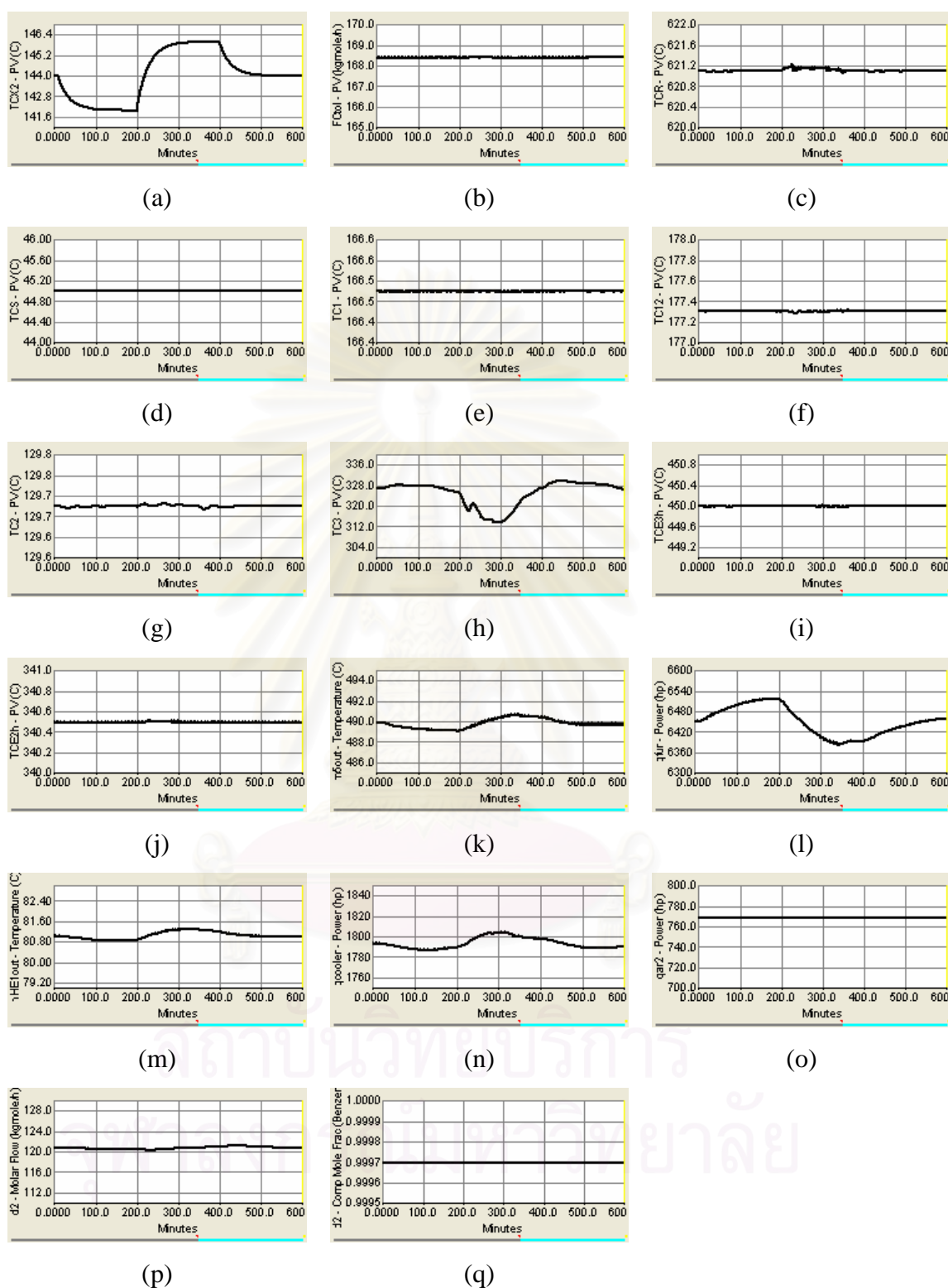

Figure 6.46: Dynamic responses of CS2 of the HDA process with minimum auxiliary reboiler to a change in the disturbance load of cold stream from the bottom of the product column

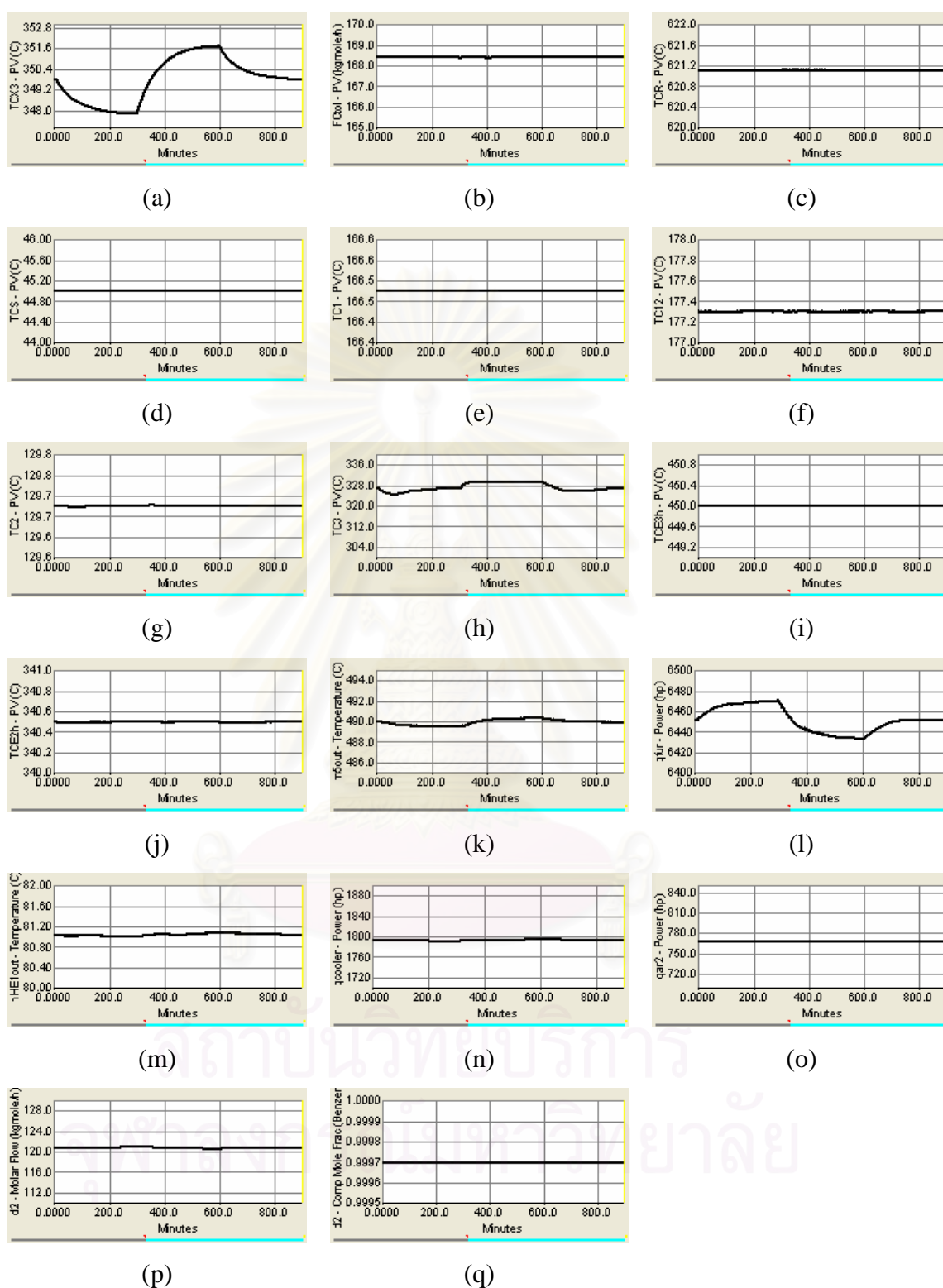

Figure 6.47: Dynamic responses of CS2 of the HDA process with minimum auxiliary reboiler to a change in the disturbance load of cold stream from the bottom of the recycle column

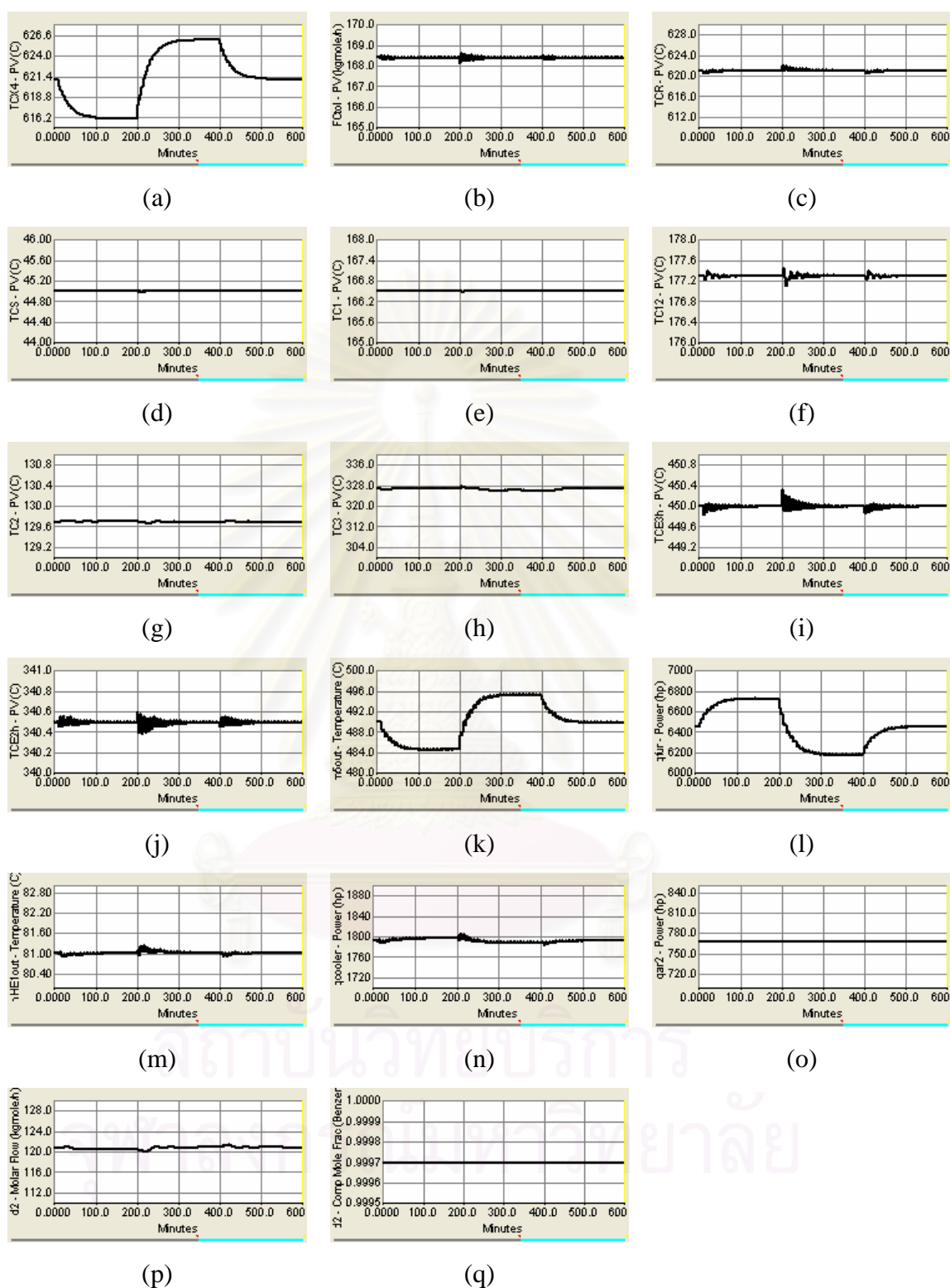

Figure 6.48: Dynamic responses of CS2 of the HDA process with minimum auxiliary reboiler to a change in the disturbance load of hot stream (reactor product)

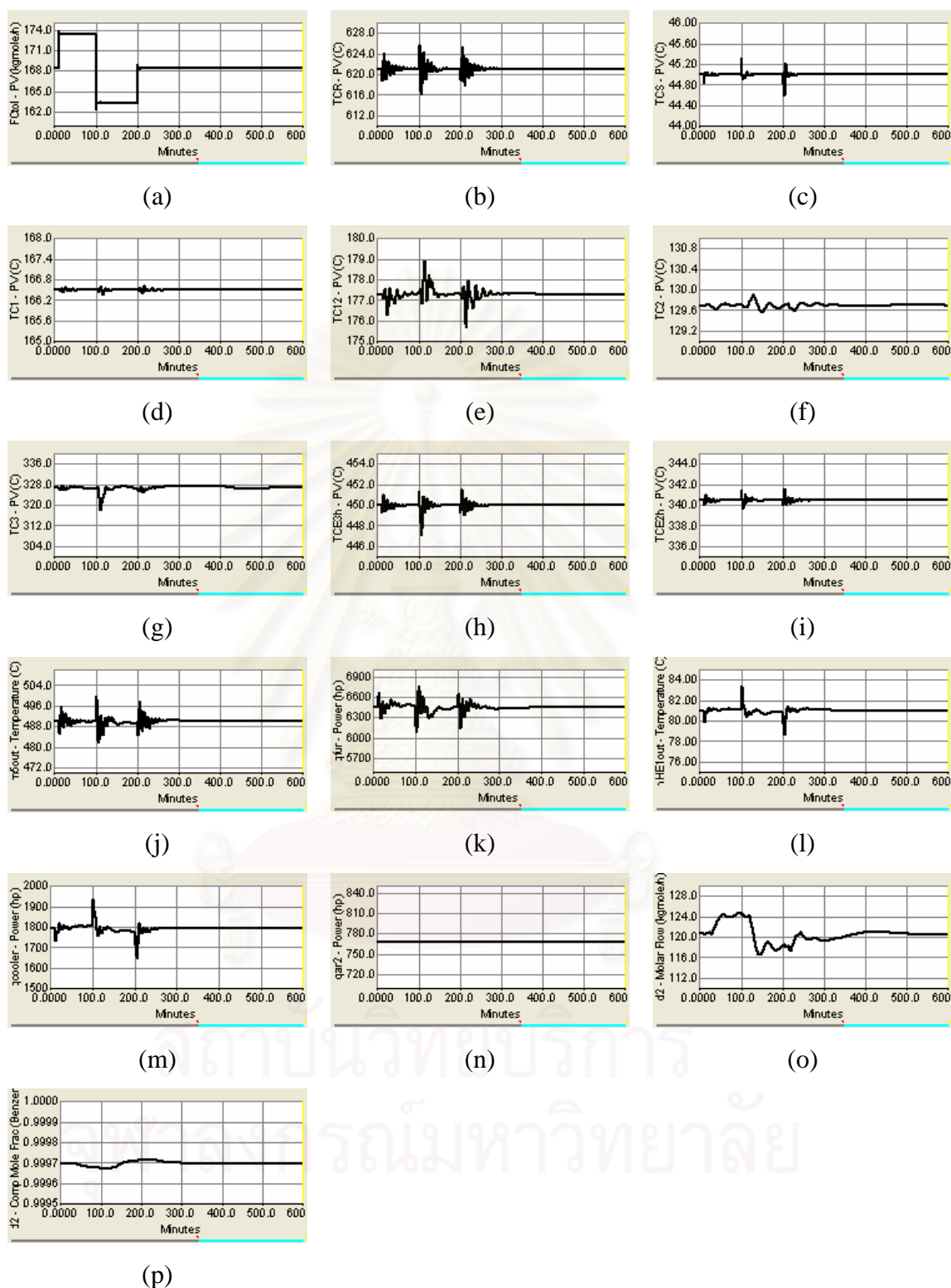

Figure 6.49: Dynamic responses of CS2 of the HDA process with minimum auxiliary reboiler to a change in the total toluene feed flowrate

for the remaining loops.

6.8.1 Dynamic Simulation Results for HDA Process with Minimum Auxiliary Reboilers: Control Structure 3

In order to illustrate the dynamic behavior of the control structure in HDA process Alternative 6 with minimum auxiliary reboilers (CS3), several disturbance loads are made. The dynamic responses of the control system are shown in Figures 6.51 to 6.56. Results for individual disturbance load changes are as follows:

6.8.1.1 Change in the Disturbance Load of Cold Stream (Reactor Feed Stream)

Figure 6.51 shows the dynamic responses to a change in the disturbance load of cold stream (reactor feed stream). This disturbance is made as follows: first the fresh toluene feed temperature is decreased from 30°C to 20°C at time equals 10 minutes, and the temperature is increased from 20°C to 40°C at time equals 100 minutes, then its temperature is returned to its nominal value of 30°C at time equals 200 minutes.

As can be seen, the dynamic responses of this control structure are better than that of the Base Case. Particularly, the tray temperature in the recycle column provides a well controlled (Figure 6.51.h) because the feed flowrate of the recycle column is flow-controlled for reducing the flow propagation when the disturbance occurs. Thus, this control structure can well handle the change in the disturbance load of the cold stream.

For the other dynamic responses of this control structure, they are similar to earlier control structures. The separator temperature and the tray temperature in the product column are well controlled (Figure 6.51.d and g) but the reactor inlet temperature and the tray temperature in the stabilizer column have small oscillations (Figure 6.51.c, e and f).

6.8.1.2 Change in the Disturbance Load of Cold Stream from the Bottoms of Stabilizer Column

Figure 6.52 shows the dynamic responses of HDA process alternative 6 (CS3) to a change in the disturbance load of cold stream which originating from the bottoms of the stabilizer column, by changing its temperature from 190°C to 188°C at time equals 10 minutes, and its temperature is increased from 188°C to 192°C at time equals 200 minutes, then its temperature is returned to its nominal value of 190°C at time equals 400 minutes.

The dynamic responses of the CS3 are better than that of the Base Case because the feed flowrate of the recycle column is flow-controlled. Thus, the effect of this disturbance is reduced before entering to the recycle column (i.e. the dynamic response of the temperature control in the recycle column of this control structure is better than the Base Case (Figure 6.52.h)). However, the other dynamic responses of the CS3 with minimum auxiliary reboiler are similar to the above control structure when this disturbance occurs.

6.8.1.3 Change in the Disturbance Load of Cold Stream from the Bottoms of Product Column

Figure 6.53 shows the dynamic responses of HDA process to a change in the disturbance load of cold stream from the bottoms of the product column, by changing its temperature from 144°C to 142°C at time equals 10 minutes, and the its temperature is increased from 142°C to 146°C at time equals 200 minutes, then its temperature is returned to its nominal value of 144°C at time equals 400 minutes.

Again, both positive and negative disturbance loads of the cold stream from the bottoms of the product column are shifted to the hot stream. The positive disturbance load will decrease the cooler duty (Figure 6.53.n). On the other hand, the negative disturbance load will decrease the furnace duty (Figure 6.53.l). From the dynamic simulation, the overall dynamic responses of this control structure are worse than that of the Base Case when the change in the disturbance

load of the cold stream from the bottoms of the product column occurs, since the performance of the tray temperature controlling in distillation column by auxiliary reboiler duty is better than that by the bypass valve. As a result, the performance of the tray temperature control recycle column is worse than that of the Base Case (Figure 6.53.h). The tray temperature in the recycle column has a deviation of 30°C and it takes long time to return to its nominal value. Besides, the well controlled occur in the separator temperature and the tray temperature in the product column (Figure 6.53.d and g), but the small oscillations happen in the reactor inlet temperature and the tray temperature of the stabilizer column (Figure 6.53.c, e and f).

However, overall dynamic responses of this control structure are better than that of the CS1 with minimum auxiliary reboiler, since the feed flowrate of the recycle column is flow-controlled. As a result, when the disturbance occurs, the effect of it is reduced before to enter to the recycle column.

6.8.1.4 Change in the Disturbance Load of Cold Stream from the Bottoms of Recycle Column

Figure 6.54 shows the dynamic responses of HDA process alternative 6 (CS3) to a change in the disturbance load of cold stream from the bottoms of the recycle column, by changing its temperature from 349.8°C to 347.8°C at time equals 10 minutes, and the its temperature is increased from 347.8°C to 351.8°C at time equals 300 minutes, then its temperature is returned to its nominal value of 349.8°C at time equals 600 minutes.

The dynamic responses of the CS3 with minimum auxiliary reboiler are worse than that of Base Case when a change in the disturbance load of cold stream from the bottoms of the recycle column happens, since the performance of the tray temperature controlling in distillation column by auxiliary reboiler duty is better than that by the bypass valve. As a result, the performance of the tray temperature control in the recycle column is worse than the Base Case control structures (Figure 6.54.h). However, the dynamic responses of this control

structure are better than that of the CS1 because the effect of this change is reduced before to enter to the recycle column.

The other dynamic responses of this control structure are similar to the dynamic responses of the previous control structure such as the separator temperature, the reactor inlet temperature, the tray temperature in the stabilizer and product column (Figure 6.54.c, d, e, f and g). For the tray temperature in the recycle column, it has a deviation about 10°C and it takes more than 700 minutes to return to its nominal value of 326.7°C .

6.8.1.5 Change in the Disturbance Load of Hot Stream (Reactor Product)

Figure 6.55 shows the dynamic responses of HDA process to a change in the disturbance load of hot stream from reactor, by changing its temperature from 621.11°C to 616.11°C at time equals 10 minutes, and the its temperature is increased from 616.11°C to 626.11°C at time equals 200 minutes, then its temperature is returned to its nominal value of 621.11°C at time equals 400 minutes.

Again, when the hot temperature decreases, it will result in decrease of the furnace inlet temperature (Figure 6.55.k). As a result, the furnace duty increases (Figure 6.55.l). On the other hand, when the hot temperature increases, the furnace duty will be decreased, since the furnace inlet temperature increases.

The dynamic responses of the CS3 with minimum auxiliary reboiler are better than that of Base Case when the change in the disturbance load of the hot stream occurs. Particularly, the tray temperature in the recycle column provides a well controlled (Figure 6.55.h), since the feed flowrate of the recycle column is flow-controlled. Thus, the effect of this change does not propagate to the recycle column. The tray temperature in the recycle column has a small deviation about 2°C and it takes over 450 minutes to return to its nominal value of 326.7°C . The separator temperature, the reactor inlet temperature and the tray temperature in the product column are slightly well controlled (Figure 6.55.c, d and g) but the

oscillation occurs in the tray temperature of the stabilizer column (Figure 6.55.e and f).

6.8.1.6 Change in the Total Toluene Feed Flowrate

Figure 6.56 shows the dynamic responses of HDA process to a change in the total toluene feed flowrates from 168.4 kgmole/hr to 173.4 kgmole/hr at time equals 10 minutes, and the its feed flowrate is decreased from 173.4 kgmole/hr to 163.4 kgmole/hr at time equals 100 minutes, then its flowrates is returned to its nominal value of 168.4 kgmole/hr at time equals 200 minutes.

The dynamic responses of this control structure are better than that of the Base Case when this disturbance occurs. Particularly, the tray temperature in the recycle column provides a well controlled (Figure 6.56.g) because the feed flowrate of the recycle column is flow-controlled for reducing the flow propagation during the disturbance occurs. In addition, the separator temperature is quite well controlled (Figure 6.56.c), the oscillations occur in the tray temperature of the stabilizer column and the reactor inlet temperature (Figure 6.56.b, d and e). A deviation of 10°C happens in the tray temperature of the recycle column.

6.9 Evaluation of the Dynamic Performance

The job of most control loops in a chemical process is one of regulation or load rejection, i.e. holding the controlled variable at its setpoint in the face of load disturbances.

The estimation of the minimum achievable variance of SISO controlled variable from normal closed-loop data. Since then, minimum variance control has been widely used as a benchmark for assessing control loop performance. However, minimum variance control based performance assessment methods cannot adequately evaluate the performance for controllers with constraints explicitly incorporated or for controllers where transient response and deterministic disturbance regulation are concerned. For assessing constrained control loop performance the proposed

Table 6.8 The initial values of controlled and manipulated variables for HDA process with minimum auxiliary reboilers: Control Structure 3

Controlled variable		Manipulated variable	
Process variable	Initial value	Process variable	Initial value
total toluene flowrate	168.4 kgmole/hr	fresh toluene feed flowrate	128.9 kgmole/hr
gas recycle stream pressure	605 psia	fresh hydrogen feed flowrate	220.5 kgmole/hr
methane in gas recycle	0.5877 mole-frac	purge flowrate	217.5 kgmole/hr
quenched temperature	621.1 °C	quench flowrate	48.5 kgmole/hr
reactor inlet temperature	621.1 °C	furnace duty	4796 kW
separator temperature	45 °C	cooler duty	1339 kW
hot outlet temperature of FEHE 2	340.5 °C	bypass flowrate of FEHE 2	266.7 kgmole/hr
hot outlet temperature of FEHE 3	450 °C	bypass flowrate of FEHE 3	180.9 kgmole/hr
separator liquid level	50 %-level	column C1 feed flowrate	171.3 kgmole/hr
column C1 pressure	150 psia	column C1 condenser duty	389.3 kW
column C1 tray-3 temperature	177.3 °C	bypass flowrate of R1	486.6 kgmole/hr
column C1 tray-6 temperature	166.5 °C	column C1 gas flowrate	8.488 kgmole/hr
column C1 base level	50 %-level	column C2 feed flowrate	162.7 kgmole/hr
column C1 reflux drum level	50 %-level	column C1 reflux flowrate	32.67 kgmole/hr
column C1 boil-up flowrate	183 kgmole/hr	cold inlet flowrate of R1	183 kgmole/hr
column C2 pressure	30 psia	column C2 condenser duty	5016 kW
column C2 tray-12 temperature	129.7 °C	bypass flowrate of R2	152.2 kgmole/hr
		auxiliary reboiler 2 (R2) duty	573.5 kW
column C2 base level	50 %-level	cold inlet flowrate of R2	387 kgmole/hr
column C2 reflux drum level	50 %-level	column C2 product flowrate	120.5 kgmole/hr
column C3 feed flowrate	42.15 kgmole/hr	column C3 feed flowrate	42.15 kgmole/hr
column C3 pressure	76.32 psia	bypass flowrate of CR	26.32 kgmole/hr
avg C3-tray 1, 2, 3, and 4 temperature	326.7 °C	bypass flowrate of R3	177.3 kgmole/hr
column C3 base level	50 %-level	column C3 bottom flowrate	2.644 kgmole/hr
column C3 reflux drum level	50 %-level	toluene recycle flowrate	39.52 kgmole/hr
column C3 boil-up flowrate	47.26 kgmole/hr	cold inlet flowrate of R3	47.26 kgmole/hr
column C3 reflux flowrate	9.94 kgmole/hr	column C3 reflux flowrate	9.94 kgmole/hr

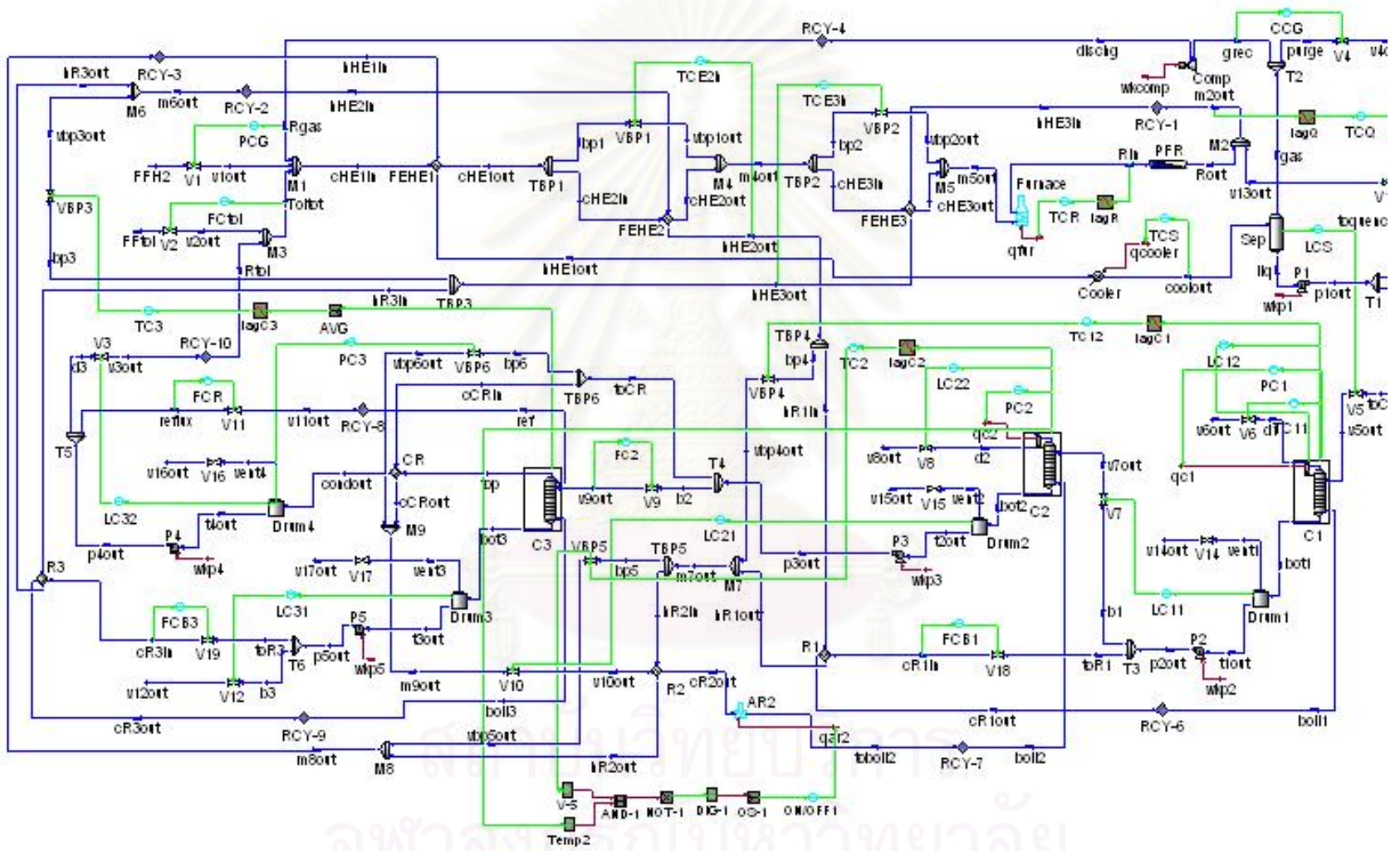

Figure 6.50: Control structures 3 of the HDA process with minimum auxiliary reboilers

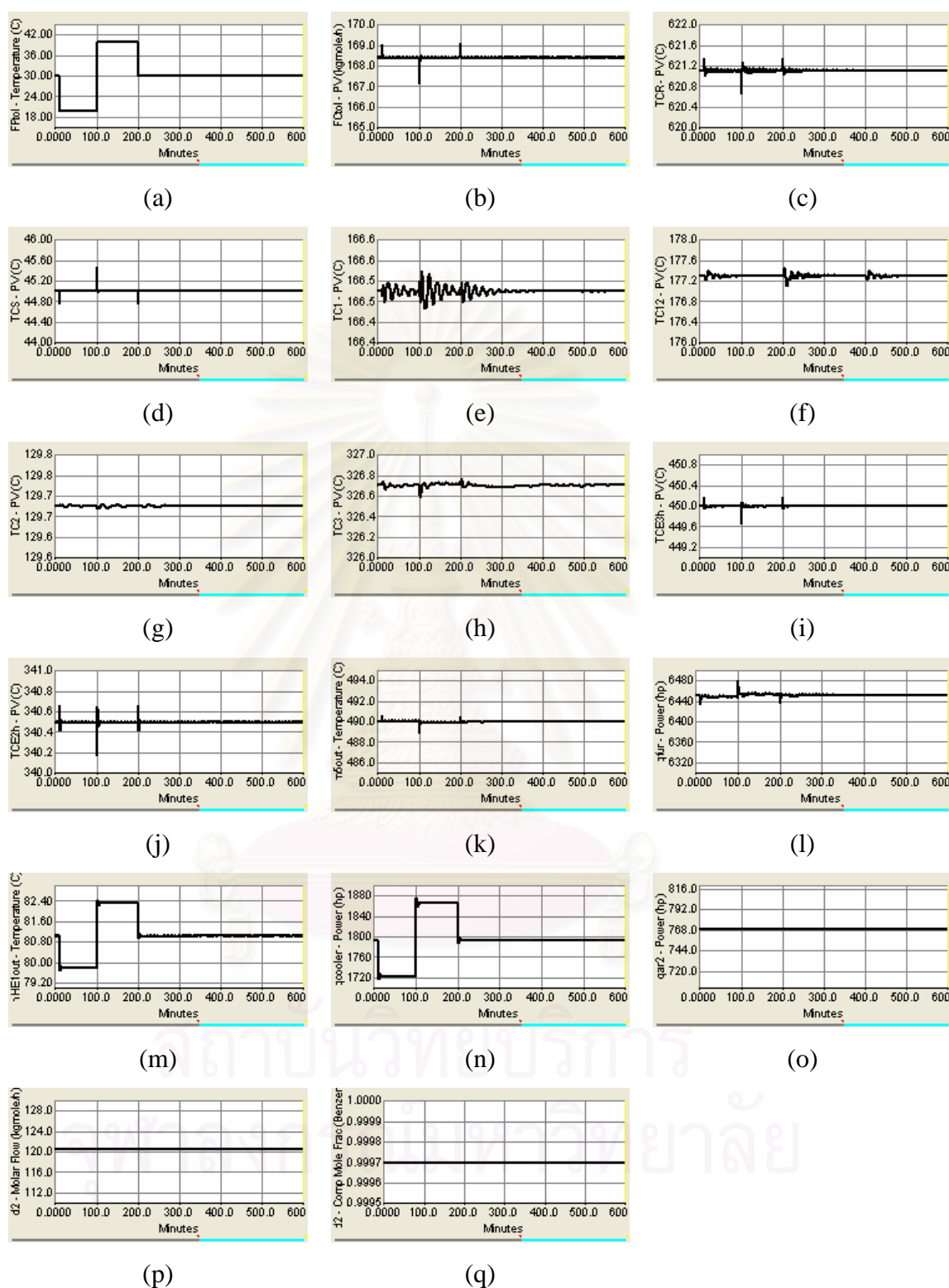

Figure 6.51: Dynamic responses of CS3 of the HDA process with minimum auxiliary reboiler to a change in the disturbance load of cold stream (reactor feed stream)

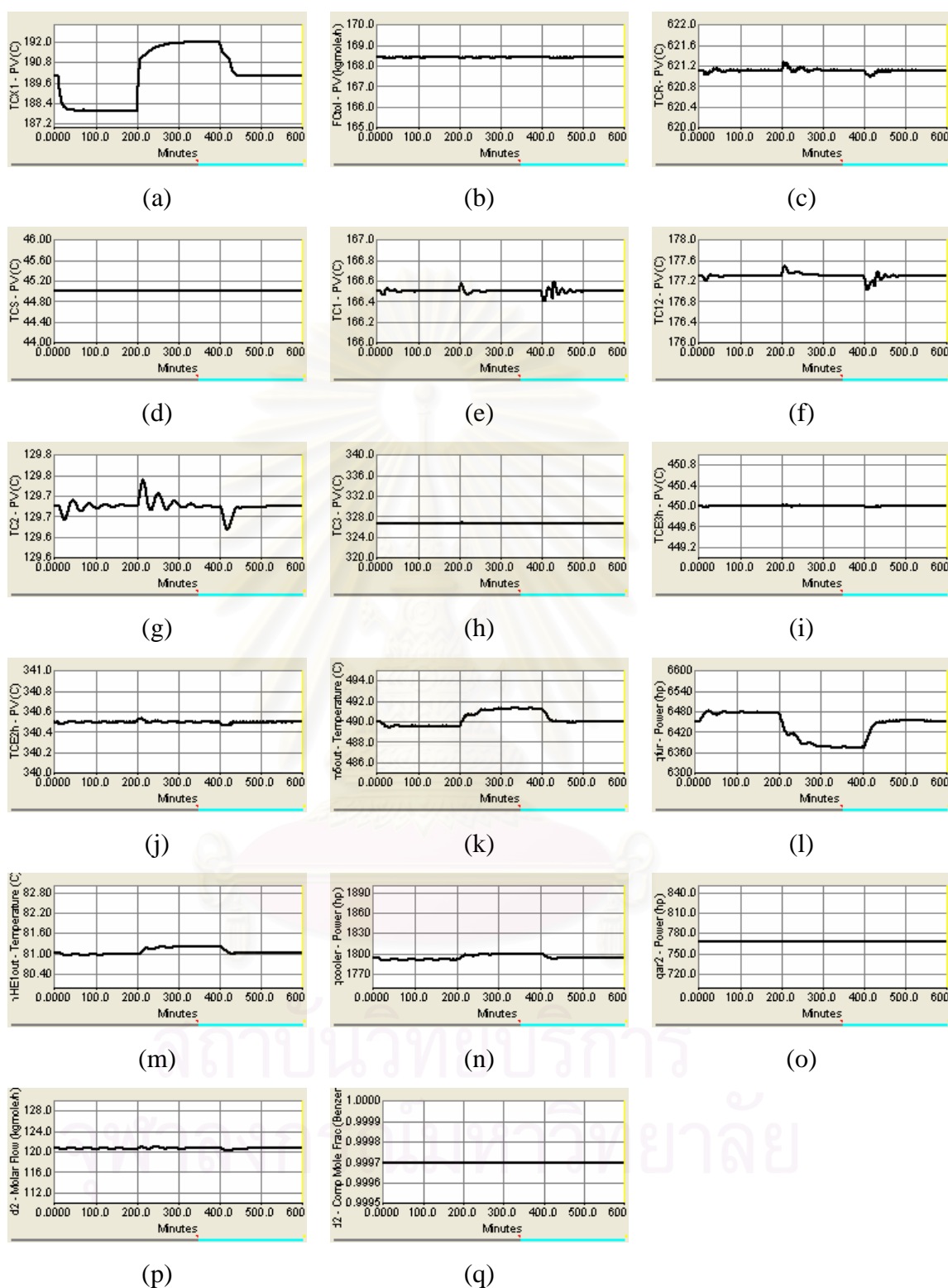

Figure 6.52: Dynamic responses of CS3 of the HDA process with minimum auxiliary reboiler to a change in the disturbance load of cold stream from the bottom of the stabilizer column

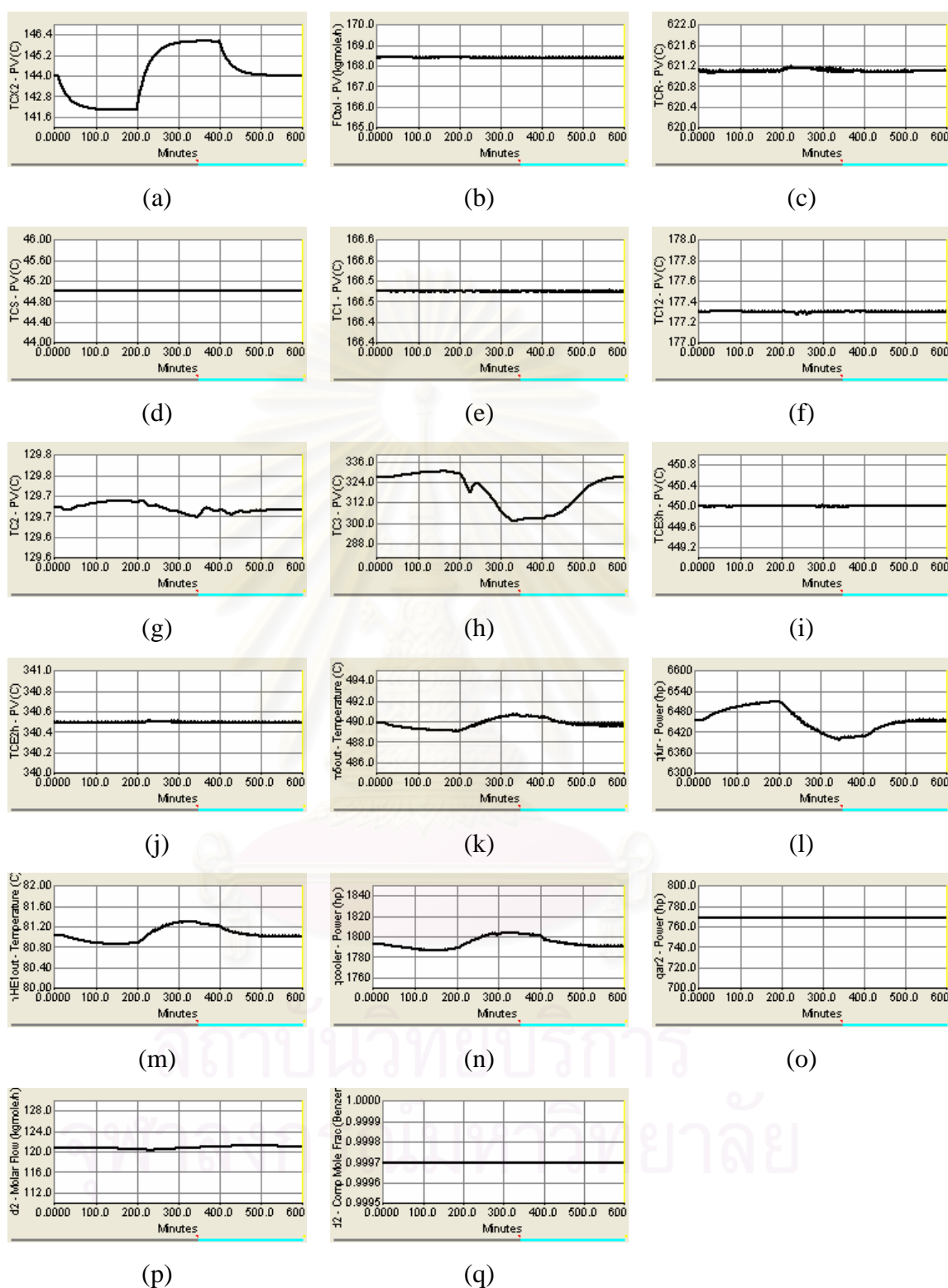

Figure 6.53: Dynamic responses of CS3 of the HDA process with minimum auxiliary reboiler to a change in the disturbance load of cold stream from the bottom of the product column

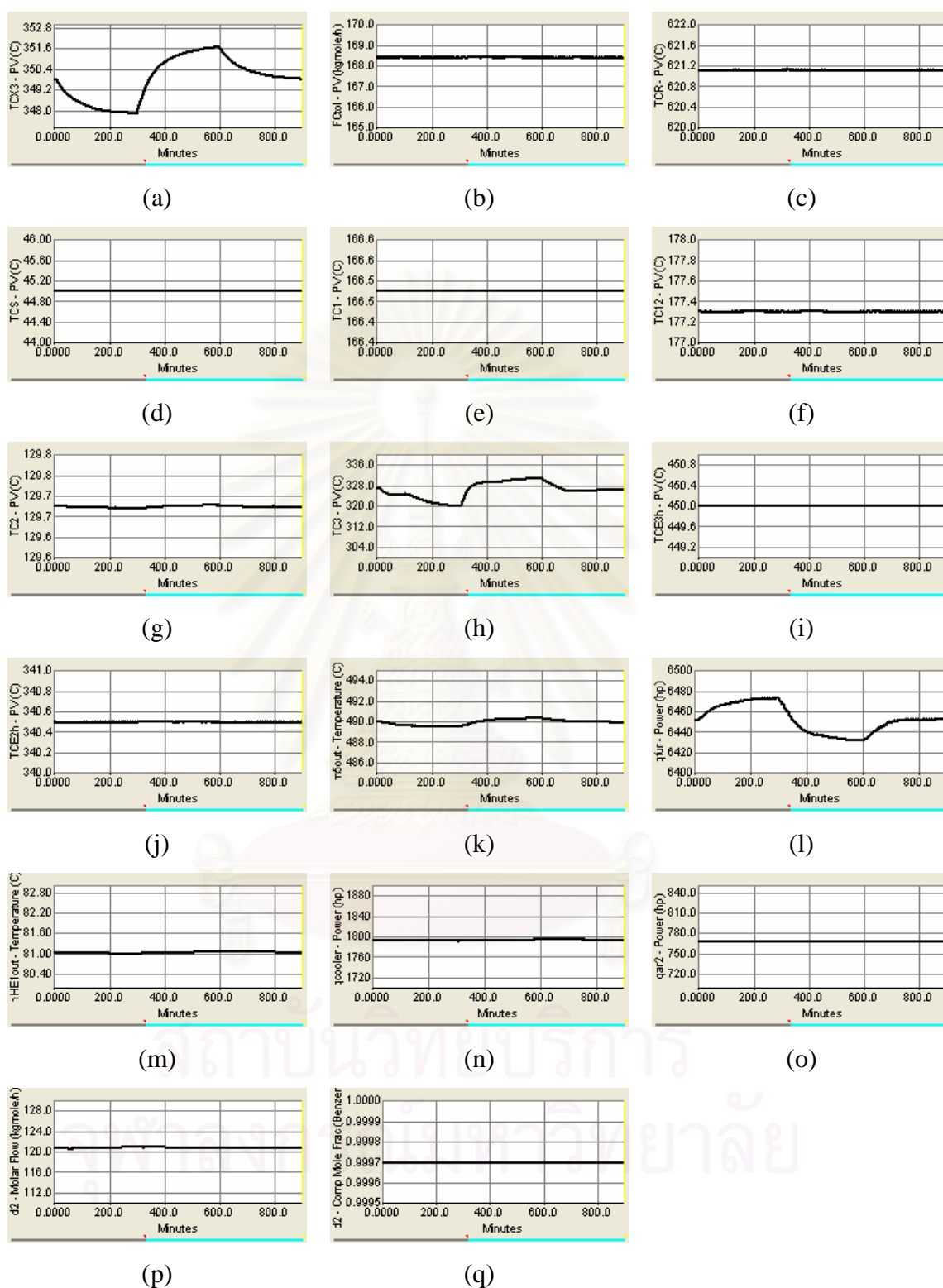

Figure 6.54: Dynamic responses of CS3 of the HDA process with minimum auxiliary reboiler to a change in the disturbance load of cold stream from the bottom of the recycle column

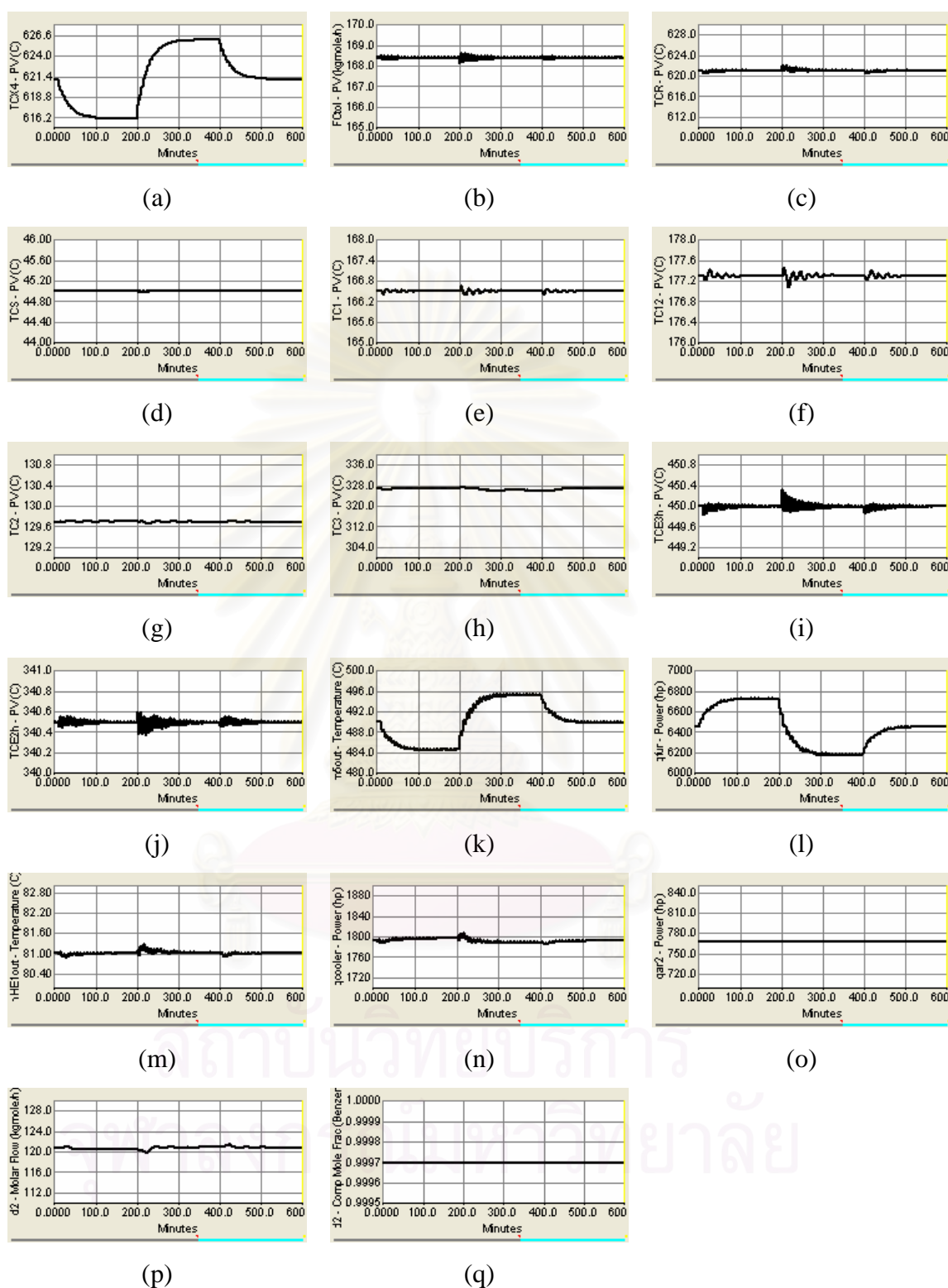

Figure 6.55: Dynamic responses of CS3 of the HDA process with minimum auxiliary reboiler to a change in the disturbance load of hot stream (reactor product)

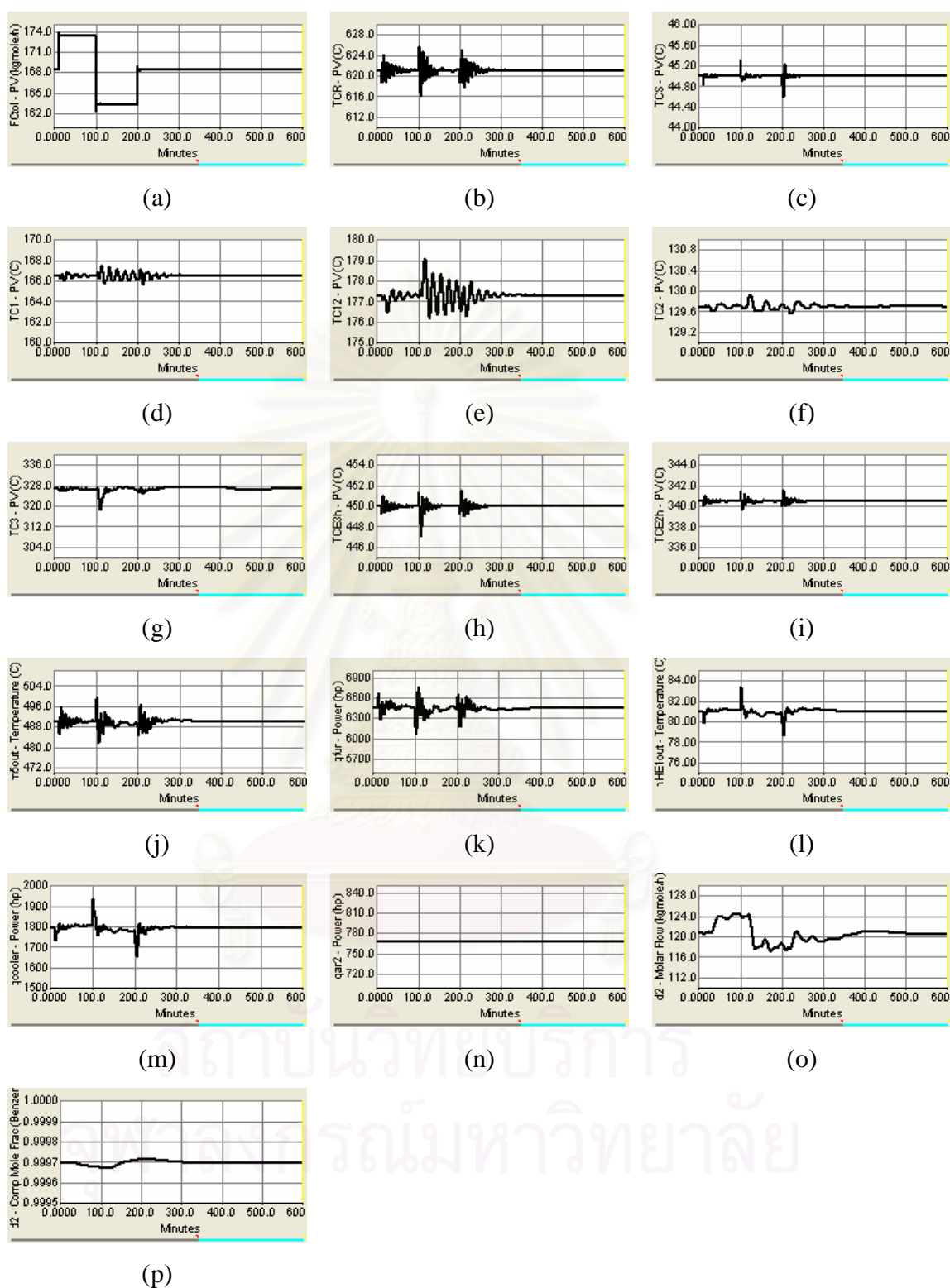

Figure 6.56: Dynamic responses of CS3 of the HDA process with minimum auxiliary reboiler to a change in the total toluene feed flowrate

the dynamic performance index is focused on time related characteristics of the controller's response to setpoint changes or deterministic disturbances. There exist several candidate performance measures such as settling time and Integral absolute Error (IAE). Integral absolute error is well known and widely used for the formulation of a dynamic performance as written below:

$$IAE = \int |\epsilon(t)| dt \quad (6.1)$$

Note that $\epsilon(t) = y_{sp}(t) - y(t)$ is the deviation (error) of the response from the desired setpoint. In this work, IAE method is used to evaluate the dynamic performance of the designed control systems. Table 6.9 shows the IAE results of HDA process with energy integration scheme (Alternative 6) with three auxiliary reboilers for all control structures. Table 6.10 shows the IAE results of HDA process with energy integration scheme (Alternative 6) with minimum auxiliary reboiler for all control structures.

Table 6.9 IAE values of HDA process with three auxiliary reboilers.

Disturbance	Integral Absolute Error (IAE)			
	Base Case	CS1	CS2	CS3
Reactor Feed	46.079	42.544	40.546	49.740
Stabilizer Column	40.425	33.841	32.719	46.056
Product Column	39.423	29.604	26.215	29.998
Recycle Column	20.690	18.964	17.275	20.020
Reactor Product	150.124	155.800	133.653	148.756
Total Toluene Feed	1152.620	424.273	422.148	532.978

Table 6.10 IAE values of HDA process with minimum auxiliary reboiler.

Disturbance	Integral Absolute Error (IAE)			
	Base Case	CS1	CS2	CS3
Reactor Feed	38.522	29.689	22.371	27.581
Stabilizer Column	68.725	45.983	39.675	45.525
Product Column	42.500	51.788	33.558	45.855
Recycle Column	16.441	17.088	14.112	19.607
Reactor Product	186.300	184.692	139.632	178.192
Total Toluene Feed	651.275	494.253	490.769	656.463

CHAPTER VII

CONCLUSIONS AND RECOMMENDATIONS

7.1 Conclusion

The problem of plantwide process control is to develop a control strategy for a complex and integrated process that satisfies the plant's design objectives. The cost of control system and process is one of the important plant's design objectives. In this thesis, the design of the most complex heat-integrated HDA process with minimum auxiliary reboiler is developed by using the heat pathway analysis. The worst case condition is selected to be the design condition that minimum heat supplies by hot process streams and maximum heat demands by cold process streams. The design strategy to minimize the equipment cost of the HDA plant. In addition, this work presents new three plantwide designed control structures. The commercial software HYSYS was utilized to carry out both the steady state and dynamic simulations.

7.1.1 Steady State Simulation Results

From the steady state simulation result, our design guarantees that the HDA process with energy integration (Alternative 6) is workable despite only one auxiliary reboiler, but the furnace of our design is bigger. However, at the worst case condition, the capital cost of the HDA plant for our design is lower by 7.35 percent compared to the earlier design by Luyben (1999).

7.1.2 Dynamic Simulation Results

In this work, the new three control structures are introduced and their information are summarized as followed.

In order to illustrate the dynamic behaviors of all control structures in HDA process (Alternative 6), several disturbance loads are made. They include a change in the cold stream (reactor feed stream), a change in the cold stream from

Table 7.1 Information of each control structure.

Control Structure	Description
Base Case	1. To control tray temperature of each distillation column by manipulating auxiliary reboiler duty
CS1	1. Logical control is applied to this control structure 2. Two-points temperature control in the stabilizer column
CS2	1. Logical control is applied to this control structure 2. Two-points temperature control in the stabilizer column 3. The feed of recycle column is flow-controlled
CS3	1. Logical control is applied to this control structure 2. Two-points temperature control in the stabilizer column 3. The feed of recycle column is flow-controlled 4. Richardson rule is applied to this control structure for to control reflux drum level of the stabilizer column

the bottom of stabilizer, product and recycle column, a change in the hot stream (reactor product) and a change in the total toluene feed flowrate.

As can be seen in a change in the cold stream (reactor feed stream), when the inlet temperature of fresh feed toluene decreases, CS2 has better dynamic responses compared to Base Case, CS1 and CS3, especially the tray temperature in the recycle column. For a change in the disturbance load of cold stream from the bottom of stabilizer column, CS2 is the best control structure for to handle this disturbance.

Both the positive and negative disturbance loads originating from the bottom of product and recycle column are shifted to the hot stream. When the temperature decreases, it will result in decrease of the hot inlet temperature of FEHE1. Therefore, the cooler duty decreases since the cooler inlet temperature decreases, but the furnace duty increases because the furnace inlet temperature decreases. On the other hand, it will result in increase of the cooler duty and decrease furnace duty when the negative disturbance load occurs. CS2 has the best dynamic responses compared to all control structures both minimum auxiliary reboiler and three auxiliary reboilers.

When a change in the hot stream (reactor product) occurs, it can be shifted to the cold stream since the hot outlet temperature of FEHE3 has to be kept

constant. CS2 has the best responses compared to other control structures, particularly the tray temperature in the recycle column.

On the last case, a change in the total toluene feed flowrate is also made for this work. As can be seen, to increase in total toluene feed flowrate raises the reaction rate, so benzene product rate increases. On the other hand, the drop in total toluene feed flowrate reduces the reaction rate, so the benzene rate drops. However, the effect of this change does not affect to the benzene product quality. Again, CS2 is the best control structure for to handle this disturbance.

7.1.3 Evaluation of the dynamic performance

In this study, IAE method is used to evaluate the dynamic performance of all control systems. For control structure with minimum auxiliary reboiler, CS2 is the most effective control structure for to handle all disturbance loads in this work, i.e. the value of IAE of CS2 is smaller than that of Base Case, CS1 and CS3.

For control structure with three auxiliary reboilers, the most dynamic responses are similar to the control structure with minimum auxiliary reboiler. Again, CS2 is the best control structure for to handle all disturbances.

7.2 Recommendations

Since IAE value of the tray temperature control of recycle column is very large, so we should improve the performance of this loop by understanding and applying control techniques such as feed forward control and cascade control etc.

REFERENCES

- Douglas, J.M. Conceptual Design of Chemical Process. New York: McGraw-Hill, (1988).
- Guthrie, K.M. Data and Techniques for preliminary Capital Cost Estimating. Chem. Eng. (1969): 114-142.
- Handogo, R., and Luyben W.L. Design and Control of a Heat-Integrated Reactor /Column Process. Ind. Eng. Chem. Res. 26 (1987): 531-538.
- Kietawarin, S. Control Structure Design Applied to Hydrodealkylation Process Plantwide Control Problem. M. Eng., Chemical Engineering, Chulalongkorn University, 2002.
- Kunlawaniteewat, J. Heat Exchanger Network Control Structure Design. M. Eng., Chemical Engineering, Chulalongkorn University, 2001.
- Luyben, M.L., Bjorn, D., Tyreus, and Luyben, W.L. Plantwide Process Control. New York: McGraw-Hill, (1999).
- Luyben, M.L., Tyreus, B.D. and Luyben, W.L. Design Plantwide Control Procedure. AIChE Journal 43 (1997): 3161-3174.
- Luyben, W.L. Control of Outlet Temperature in Adiabatic Tubular Reactor. Ind. Eng. Chem. Res. 39 (2000): 1271-1278.
- Luyben, W.L. Design and Control of Gas-Phase Reactor/Recycle Process with Reversible Exothermic Reactions. Ind. Eng. Chem. Res. 39 (2000): 1529-1538.
- Luyben, W.L. Plantwide Dynamic Simulations in Chemical Processing and Control. New York: Marcel Dekker, (2002).
- Ploypaisansang, A. Resilient Heat Exchanger Network Design of Hydrodealkylation Process. M. Eng., Chemical Engineering, Chulalongkorn University, 2003.

- Qiu, Q.F., Rangaiah, G.P. and Krishnaswamy, P.R. Application of a plant-wide control design to the HDA process. Computers and Chemical Engineering journal 27 (2003): 73-94.
- Seborg, D.E., Edgar, T.F. and Mellichamp, D.A. Process Dynamic and Control. New York: John Wiley & Sons, (1989).
- Skogestad, S. Control structure design for complete chemical plants. Computers and Chemical Engineering journal 28 (2004): 219-234.
- Terrill, D.L. and Douglas, J.M. A T-H Method for Heat Exchanger Network Synthesis. Ind. Eng. Chem. Res. 26 (1987): 175-179.
- Thaicharoen, C. Design of Control Structure for Energy-Integrated Hydrodealkylation (HDA) Process. M. Eng., Chemical Engineering, Chulalongkorn University, 2004.
- Ulrich, G. D. A Guide to Chemical Engineering Process Design and Economics. New York: Wiley, (1984).
- Wongsri, M. Resilient of Heat Exchanger Network Design, D. Sc. Dissertation Sever Institute of Technology Washington University, 1990.
- Wongsri, M. and Hermawan, Y. D. Heat Pathway Management for Complex Energy Integrated Plant: Dynamic Simulation of HDA Plant. J. Chin. Inst. Chem. Engrs. 36 (2005): 1-27.



APPENDICES

สถาบันวิทยบริการ
จุฬาลงกรณ์มหาวิทยาลัย

APPENDIX A

COST EQUATIONS AND CURVES FOR THE CAPCOST PROGRAM

The purpose of this appendix is to present the equations and figures that describe the relationships used in the capital equipment-costing program CAPCOST. The program is based on the module factor approach to costing that was originally introduced by Guthrie and modified by Ulrich.

A.1 Purchased Equipment Costs

All the data for the purchased cost of equipment were obtained from a survey of equipment manufactures during the period May to September of 2001, so an average value of the CEPCI of 397 over this period should be used when accounting for inflation. The data for the purchased cost of the equipment, at ambient operating pressure and using carbon steel construction, C_p^0 , was fitted to the following equation:

$$\log C_p^0 = K_1 + K_2 \log(A) + K_3 [\log(A)]^2 \quad (1)$$

where A is the capacity or size parameter for the equipment. The K_1 , K_2 and K_3 are constant.

A.2 Pressure Factors

A.2.1 Pressure Factors for Process Vessels

The pressure factor for horizontal and vertical process vessels of diameter D meters and operating at a pressure of P barg is based on the ASME code for pressure vessel design. At base material conditions using a maximum allowable stress for carbon steel, S , of 944 bar, a weld efficiency, E , of 0.9, a minimum allowable vessel thickness of 0.0063 m (1/4 inch), and a corrosion allowance, CA , of 0.00315 m (1/8 inch) gives the following expression:

$$F_{p,vessel} = \frac{\frac{(P+1)D}{2[850-0.6(P+1)]} + 0.00315}{0.0063} \quad (2)$$

If $F_{p,vessel}$ is less than 1, then $F_{p,vessel} = 1$. For pressures below -0.5 barg, $F_{p,vessel} = 1.25$.

A.2.2 Pressure Factors for Other Process Equipment

The pressure factors, F_p for the remaining process equipment are given by the following general form:

$$\log F_p = C_1 + C_2 \log P + C_3 (\log P)^2 \quad (3)$$

The units of pressure, P , are bar gauge or barg unless stated otherwise. The pressure factors are always greater than unity; the values of constants depend on type of equipment. The values for the constants were regressed from data in Guthrie and Ulrich.

A.3 Material Factors and Bare Module Factors

A.3.1 Bare Module and Material Factors for Heat Exchangers, Process Vessel, and Pumps

The bare module factors for this equipment are given by the following equation:

$$C_{BM} = C_p^0 F_{BM} = C_p^0 (B_1 + B_2 F_M F_p) \quad (4)$$

The values of the constants B_1 and B_2 are given in Table A.1. The bare module cost for ambient pressure and carbon steel construction, C_{BM}^0 and the bare module factor for the equipment at these conditions, F_{BM}^0 are found by setting F_M and F_p equal to unity.

Table A.1 Constant for Bare Module Factor to be used in Equation A.4

Equipment Type	Equipment Description	B ₁	B ₂
Heat exchangers	double pipe, multiple pipe, scraped wall and spiral tube	1.74	1.55
	fixed tube sheet, floating head, U-tube, bayonet	1.63	1.66
	kettle reboiler and Teflon tube		
Process vessels	air cooler, spiral plate and flat plate	0.96	1.21
	horizontal	1.49	1.52
Pumps	vertical (including towers)	2.25	1.82
	reciprocating	1.89	1.35
	positive displacement	1.89	1.35
	centrifugal	1.89	1.35

Table A.2 Equations for Bare Module Cost

Equipment Type	Equation for Bare module Cost
Compressors and blowers without drives	$C_{BM} = C_p^0 F_{BM}$
Drives for compressors and blowers	$C_{BM} = C_p^0 F_{BM}$
Evaporators and vaporizers	$C_{BM} = C_p^0 F_{BM} F_p$
Fans with electric drives	$C_{BM} = C_p^0 F_{BM} F_p$
Fired heaters and furnaces	$C_{BM} = C_p^0 F_{BM} F_p F_T$ <p>F_T is the superheat correlation factor for steam boilers ($F_T=1$ for other heaters and furnaces) and is given by</p> $F_T = 1 + 0.00184\Delta T - 0.00000335(\Delta T)^2$ <p>where ΔT is the amount of superheat ($^{\circ}\text{C}$)</p>
Power recovery equipment	$C_{BM} = C_p^0 F_{BM}$
Sieve trays, valve trays and demister pads	$C_{BM} = C_p^0 N F_{BM} F_q$ <p>Where N is the number of trays and F_q is a quantity factor trays only given by</p> $\log_{10} F_q = 0.4771 + 0.08516 \log_{10} N - 0.3473(\log_{10} N)^2 \text{ for } N < 20$ $F_q = 1 \text{ for } N \geq 20$
Tower packing	$C_{BM} = C_p^0 F_{BM}$

A.3.2 Bare Module and Material Factors for the Remaining Process Equipment

For the remaining equipment, the bare module costs are related to the material and pressure factors by equations different from Equation (4). The form of these equations is given in Table A.2.



สถาบันวิทยบริการ
จุฬาลงกรณ์มหาวิทยาลัย

APPENDIX B

TUNING OF CONTROL STRUCTURES

B.1 Tuning Controllers

Notice throughout this work uses several types of controllers such as P, PI, and PID controllers. They depend on the control loop. In theory, control performance can be improved by the use of derivative action but in practice the use of derivative has some significant drawbacks:

1. Three tuning constants must be specified.
2. Signal noise is amplified.
3. Several types of PID control algorithms are used, so important to careful that the right algorithm is used with its matching tuning method.
4. The simulation is an approximation of the real plant. If high performance controllers are required to get good dynamics from the simulation, the real plant may not work well.

B.2 Tuning Flow, Level and Pressure Loops

The dynamics of flow measurement are fast. The time constants for moving control valves are small. Therefore, the controller can be turned with a small integral or reset time constant. A value of $\tau_I = 0.3$ minutes work in most controllers. The value of controller gain should be kept modest because flow measurement signal are sometime noisy due to the turbulent flow through the orifice plate. A value of controller gain of $K_C = 0.5$ is often used. Derivative action should not be used.

Most level controllers should use proportional-only action with a gain of 1 to 2. This provides the maximum amount of flow smoothing. Proportional

control means there will be steady state offset (the level will not be returned to its setpoint value). However, maintaining a liquid level at a certain value is often not necessary when the liquid capacity is simply being used as surge volume. So the recommended tuning of a level controller is $K_C = 2$.

Most pressure controllers can be fairly easily tuned. The process time constant is estimated by dividing the gas volume of the system by the volumetric flowrate of gas flowing through the system. Setting the integral time equal to about 2 to 4 times the process time constant and using a reasonable controller gain usually gives satisfactory pressure control. Typical pressure controller tuning constants for columns and tanks are $K_C = 2$ and $\tau_I = 10$ minutes.

B.3 Relay- Feedback Testing

The relay-feedback test is a tool that serves a quick and simple method for identifying the dynamic parameters that are important for to design a feedback controller. The results of the test are the ultimate gain and the ultimate frequency. This information is usually sufficient to permit us to calculate some reasonable controller tuning constants.

The method consists of merely inserting an on-off relay in the feedback loop. The only parameter that must be specified is the height of the relay, h . This height is typically 5 to 10 percent of the controller output scale. The loop starts to oscillate around the setpoint with the controller output switching every time the process variable (PV) signal crosses the setpoint. Figure B.1 shows the PV and OP signals from a typical relay-feedback test.

The maximum amplitude (a) of the PV signal is used to calculate the ultimate gain, K_U from the equation

$$K_U = \frac{4h}{a\pi} \quad (1)$$

The period of the output PV curve is the ultimate period, P_U from these two parameters controller tuning constants can be calculated for PI and PID

controllers, using a variety of tuning methods proposed in the literature that require only the ultimate gain and the ultimate frequency, e.g. Ziegler-Nichols, Tyreus-Luyben.

The test has many positive features that have led to its widespread use in real plants as well in simulation studies:

1. Only one parameter has to be specified (relay height).
2. The time it takes to run the test is short, particularly compared to the extended periods required for methods like PRBS.
3. The test is closedloop, so the process is not driven away from the setpoint.
4. The information obtained is very accurate in the frequency range that is important for the design of a feedback controller.
5. The impact of load changes that occur during the test can be detected by a change to asymmetric pulses in the manipulated variable.

All these features make relay-feedback testing a useful identification tool. Knowing the ultimate gain, K_U and the ultimate period, P_U permits us to calculate controller settings. There are several methods that require only these two parameters. The Ziegler-Nichols tuning equations for a PI controller are:

$$K_C = K_U/2.2 \quad (2)$$

$$\tau_I = P_U/1.2 \quad (3)$$

These tuning constants are frequently too aggressive for many chemical engineering applications. The Tyreus-Luyben tuning method provides more conservative settings with increased robustness. The TL equations for a PI controller are:

$$K_C = K_U/3.2 \quad (4)$$

$$\tau_I = 2.2P_U \quad (5)$$

B.4 Inclusion of Lags

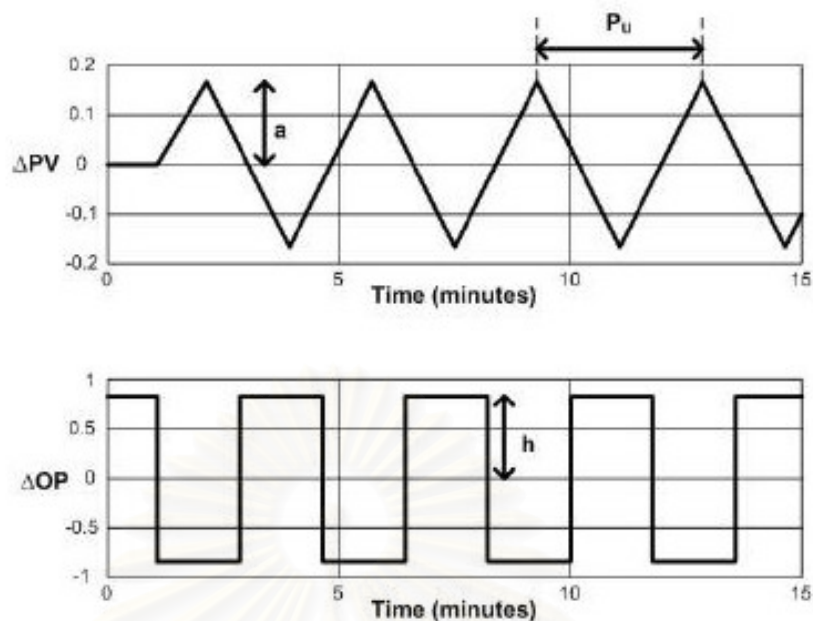

Figure B.1: Input and Output from Relay-Feedback Test

Table B.1 Typical measurement lags

		Number	Time constant (minutes)	Type
Temperature	Liquid	2	0.5	First-order lags
	Gas	3	1	First-order lags
Composition	Chromatograph	1	3 to 10	Deadtime

Any real physical system has many lags. Measurement and actuator lags always exist. In simulations, however, these lags are not part of the unit models. Much more aggressive tuning is often possible on the simulation than is possible in the real plant. Thus the predictions of dynamic performance can be overly optimistic. This is poor engineering. A conservative design is needed.

Realistic dynamic simulations require that we explicitly include lags and/or dead times in all the important loops. Usually this means controllers that affect Product quality or process constraint. Table B.1 summarizes some recommended lags to include in several different types of control loops.

APPENDIX C

PARAMETER TUNING

Table C.1 parameter tuning of the Base Case of HDA process with three auxiliary reboilers

Controller	Controlled variable	Manipulated variable	Tuning parameter			Control action	PV range
			K _c	τ_I	τ_D		
FCtol	total toluene flowrate	fresh feed toluene valve: V2	0.5	0.3	-	reverse	0-300 kmole/hr
FCR	Col.3 reflux flowrate	Col.3 reflux valve: V11	0.5	0.3	-	reverse	0-20 kmole/hr
FCB1	Col.1 boil up flowrate	cold inlet valve of R1: V18	0.5	0.3	-	reverse	130-230 kmole/hr
FCB2	Col.2 boil up flowrate	cold inlet valve of R2: V10	0.5	0.3	-	reverse	300-400 kmole/hr
FCB3	Col.3 boil up flowrate	cold inlet valve of R3: V19	0.5	0.3	-	reverse	20-80 kmole/hr
PCG	gas recycle pressure	fresh feed hydrogen valve: V1	2	10	-	reverse	500-700 psi
PC1	Col.1 pressure	Col.1 gas valve: V6	2	10	-	direct	100-200 psi
PC2	Col.2 pressure	Col.2 condenser duty: qc2	2	10	-	direct	20-40 psi
PC3	Col.3 pressure	bypass valve of CR: VBP6	2	10	-	reverse	50-100 psi
TCR	reactor inlet temperature	furnace duty: qfur	0.48	1.64	0.364	reverse	565.56-676.67°C
TC1	Col.1 tray-6 temperature	auxiliary reboiler1 duty: qar1	5.64	1.30	0.288	reverse	100-200°C
TC2	Col.2 tray-12 temperature	auxiliary reboiler2 duty: qar2	2.00	8.00	0.16	reverse	93.33-148.89°C
TC3	Avg. temp. of Col.3 Tray 1, 2, 3 and 4	auxiliary reboiler3 duty: qar3	3.99	5.61	1.25	reverse	275-375°C
TCQ	quenched temperature	quench valve: V13	1.22	3.85	0.856	direct	565.56-676.67°C
TCS	separator temperature	cooler duty: qcooler	1.64	0.33	0.0732	direct	30-100°C
TCE2h	hot outlet temp. of FEHE2	bypass valve of FEHE2: VBP1	11.5	0.934	0.207	reverse	300-400°C
TCE3h	hot outlet temp. of FEHE3	bypass valve of FEHE3: VBP2	9.93	0.593	0.132	reverse	400-500°C
LC11	Col.1 base level	Col.2 feed valve: V7	2	-	-	direct	0-100 %
LC12	Col.1 reflux drum level	Col.1 condenser duty: qc1	2	-	-	reverse	0-100 %
LC21	Col.2 base level	Col.3 feed valve: V9	2	-	-	direct	0-100 %
LC22	Col.2 reflux drum level	Col.2 product valve: V8	2	-	-	direct	0-100 %
LC31	Col.3 base level	Col.3 bottom valve: V12	2	-	-	direct	0-100 %
LC32	Col.3 reflux drum level	toluene recycle valve: V3	2	-	-	direct	0-100 %
LCS	Separator liquid level	Col.1 feed valve: V5	2	-	-	direct	0-100 %
CCG	Methane in gas recycle	purge valve: V4	0.2	15	-	direct	0-100 %

Table C.2 parameter tuning of the CS1 of HDA process with three auxiliary reboilers

Controller	Controlled variable	Manipulated variable	Tuning parameter			Control action	PV range
			Kc	τ_I	τ_D		
FCtol	total toluene flowrate	fresh feed toluene valve: V2	0.5	0.3	-	reverse	0-300 kmole/hr
FCR	Col.3 reflux flowrate	Col.3 reflux valve: V11	0.5	0.3	-	reverse	0-20 kmole/hr
FCB1	Col.1 boil up flowrate	cold inlet valve of R1: V18	0.5	0.3	-	reverse	130-230 kmole/hr
FCB2	Col.2 boil up flowrate	cold inlet valve of R2: V10	0.5	0.3	-	reverse	300-400 kmole/hr
FCB3	Col.3 boil up flowrate	cold inlet valve of R3: V19	0.5	0.3	-	reverse	20-80 kmole/hr
PCG	gas recycle pressure	fresh feed hydrogen valve: V1	2	10	-	reverse	500-700 psi
PC1	Col.1 pressure	Col.1 gas valve: V6	2	10	-	direct	100-200 psi
PC2	Col.2 pressure	Col.2 condenser duty: qc2	2	10	-	direct	20-40 psi
PC3	Col.3 pressure	bypass valve of CR: VBP6	2	10	-	reverse	50-100 psi
TCR	reactor inlet temperature	furnace duty: qfur	0.48	1.64	0.364	reverse	565.56-676.67°C
TC11	Col.1 tray-6 temperature	Col.1 reflux flowrate	6.33	0.0996	0.0221	direct	100-200°C
TC12	Col.1 tray-3 temperature	bypass valve of R1: VBP4	4.38	0.726	0.161	direct	121.11-232.22°C
TC2	Col.2 tray-12 temperature	bypass valve of R2: VBP5	30	5	-	direct	93.33-148.89°C
TC3	Avg. temp. of Col.3 Tray 1, 2, 3 and 4	bypass valve of R3: VBP3	4	10	-	direct	275-375°C
TCQ	quenched temperature	quench valve: V13	1.22	3.85	0.856	direct	565.56-676.67°C
TCS	separator temperature	cooler duty: qcooler	1.64	0.33	0.0732	direct	30-100°C
TCE2h	hot outlet temp. of FEHE2	bypass valve of FEHE2: VBP1	11.5	0.934	0.207	reverse	300-400°C
TCE3h	hot outlet temp. of FEHE3	bypass valve of FEHE3: VBP2	9.93	0.593	0.132	reverse	400-500°C
LC11	Col.1 base level	Col.2 feed valve: V7	2	-	-	direct	0-100 %
LC12	Col.1 reflux drum level	Col.1 condenser duty: qc1	2	-	-	reverse	0-100 %
LC21	Col.2 base level	Col.3 feed valve: V9	2	-	-	direct	0-100 %
LC22	Col.2 reflux drum level	Col.2 product valve: V8	2	-	-	direct	0-100 %
LC31	Col.3 base level	Col.3 bottom valve: V12	2	-	-	direct	0-100 %
LC32	Col.3 reflux drum level	toluene recycle valve: V3	2	-	-	direct	0-100 %
LCS	Separator liquid level	Col.1 feed valve: V5	2	-	-	direct	0-100 %
CCG	Methane in gas recycle	purge valve: V4	0.2	15	-	direct	0-100 %

Table C.3 parameter tuning of the CS2 of HDA process with three auxiliary reboilers

Controller	Controlled variable	Manipulated variable	Tuning parameter			Control action	PV range
			Kc	τ_I	τ_D		
FCtol	total toluene flowrate	fresh feed toluene valve: V2	0.5	0.3	-	reverse	0-300 kmole/hr
FCR	Col.3 reflux flowrate	Col.3 reflux valve: V11	0.5	0.3	-	reverse	0-20 kmole/hr
FCB1	Col.1 boil up flowrate	cold inlet valve of R1: V18	0.5	0.3	-	reverse	130-230 kmole/hr
FC2	Col.3 feed flowrate	Col.3 feed valve: V9	0.5	0.3	-	reverse	0-80 kmole/hr
FCB3	Col.3 boil up flowrate	cold inlet valve of R3: V19	0.5	0.3	-	reverse	20-80 kmole/hr
PCG	gas recycle pressure	fresh feed hydrogen valve: V1	2	10	-	reverse	500-700 psi
PC1	Col.1 pressure	Col.1 gas valve: V6	2	10	-	direct	100-200 psi
PC2	Col.2 pressure	Col.2 condenser duty: qc2	2	10	-	direct	20-40 psi
PC3	Col.3 pressure	bypass valve of CR: VBP6	2	10	-	reverse	50-100 psi
TCR	reactor inlet temperature	furnace duty: qfur	0.48	1.64	0.364	reverse	565.56-676.67°C
TC11	Col.1 tray-6 temperature	Col.1 reflux flowrate	6.33	0.0996	0.0221	direct	100-200°C
TC12	Col.1 tray-3 temperature	bypass valve of R1: VBP4	4.38	0.726	0.161	direct	121.11-232.22°C
TC2	Col.2 tray-12 temperature	bypass valve of R2: VBP5	30	5	-	direct	93.33-148.89°C
TC3	Avg. temp. of Col.3 Tray 1, 2, 3 and 4	bypass valve of R3: VBP3	4	10	-	direct	275-375°C
TCQ	quenched temperature	quench valve: V13	1.22	3.85	0.856	direct	565.56-676.67°C
TCS	separator temperature	cooler duty: qcooler	1.64	0.33	0.0732	direct	30-100°C
TCE2h	hot outlet temp. of FEHE2	bypass valve of FEHE2: VBP1	11.5	0.934	0.207	reverse	300-400°C
TCE3h	hot outlet temp. of FEHE3	bypass valve of FEHE3: VBP2	9.93	0.593	0.132	reverse	400-500°C
LC11	Col.1 base level	Col.2 feed valve: V7	2	-	-	direct	0-100 %
LC12	Col.1 reflux drum level	Col.1 condenser duty: qc1	2	-	-	reverse	0-100 %
LC21	Col.2 base level	cold inlet valve of R2: V10	2	-	-	direct	0-100 %
LC22	Col.2 reflux drum level	Col.2 product valve: V8	2	-	-	direct	0-100 %
LC31	Col.3 base level	Col.3 bottom valve: V12	2	-	-	direct	0-100 %
LC32	Col.3 reflux drum level	toluene recycle valve: V3	2	-	-	direct	0-100 %
LCS	Separator liquid level	Col.1 feed valve: V5	2	-	-	direct	0-100 %
CCG	Methane in gas recycle	purge valve: V4	0.2	15	-	direct	0-100 %

Table C.4 parameter tuning of the CS3 of HDA process with three auxiliary reboilers

Controller	Controlled variable	Manipulated variable	Tuning parameter			Control action	PV range
			Kc	τ_I	τ_D		
FCtol	total toluene flowrate	fresh feed toluene valve: V2	0.5	0.3	-	reverse	0-300 kmole/hr
FCR	Col.3 reflux flowrate	Col.3 reflux valve: V11	0.5	0.3	-	reverse	0-20 kmole/hr
FCB1	Col.1 boil up flowrate	cold inlet valve of R1: V18	0.5	0.3	-	reverse	130-230 kmole/hr
FC2	Col.3 feed flowrate	Col.3 feed valve: V9	0.5	0.3	-	reverse	0-80 kmole/hr
FCB3	Col.3 boil up flowrate	cold inlet valve of R3: V19	0.5	0.3	-	reverse	20-80 kmole/hr
PCG	gas recycle pressure	fresh feed hydrogen valve: V1	2	10	-	reverse	500-700 psi
PC1	Col.1 pressure	Col.1 condenser duty: qc1	2	10	-	direct	100-200 psi
PC2	Col.2 pressure	Col.2 condenser duty: qc2	2	10	-	direct	20-40 psi
PC3	Col.3 pressure	bypass valve of CR: VBP6	2	10	-	reverse	50-100 psi
TCR	reactor inlet temperature	furnace duty: qfur	0.48	1.64	0.364	reverse	565.56-676.67°C
TC11	Col.1 tray-6 temperature	Col.1 gas valve: V6	5	2	0.0212	reverse	100-200°C
TC12	Col.1 tray-3 temperature	bypass valve of R1: VBP4	4.38	0.726	0.161	direct	121.11-232.22°C
TC2	Col.2 tray-12 temperature	bypass valve of R2: VBP5	30	5	-	direct	93.33-148.89°C
TC3	Avg. temp. of Col.3 Tray 1, 2, 3 and 4	bypass valve of R3: VBP3	4	10	-	direct	275-375°C
TCQ	quenched temperature	quench valve: V13	1.22	3.85	0.856	direct	565.56-676.67°C
TCS	separator temperature	cooler duty: qcooler	1.64	0.33	0.0732	direct	30-100°C
TCE2h	hot outlet temp. of FEHE2	bypass valve of FEHE2: VBP1	11.5	0.934	0.207	reverse	300-400°C
TCE3h	hot outlet temp. of FEHE3	bypass valve of FEHE3: VBP2	9.93	0.593	0.132	reverse	400-500°C
LC11	Col.1 base level	Col.2 feed valve: V7	2	-	-	direct	0-100 %
LC12	Col.1 reflux drum level	Col.1 reflux flowrate	2	-	-	direct	0-100 %
LC21	Col.2 base level	cold inlet valve of R2: V10	2	-	-	direct	0-100 %
LC22	Col.2 reflux drum level	Col.2 product valve: V8	2	-	-	direct	0-100 %
LC31	Col.3 base level	Col.3 bottom valve: V12	2	-	-	direct	0-100 %
LC32	Col.3 reflux drum level	toluene recycle valve: V3	2	-	-	direct	0-100 %
LCS	Separator liquid level	Col.1 feed valve: V5	2	-	-	direct	0-100 %
CCG	Methane in gas recycle	purge valve: V4	0.2	15	-	direct	0-100 %

Table C.5 parameter tuning of the Base Case of HDA with minimum auxiliary reboilers

Controller	Controlled variable	Manipulated variable	Tuning parameter			Control action	PV range
			Kc	τ_I	τ_D		
FCtol	total toluene flowrate	fresh feed toluene valve: V2	0.5	0.3	-	reverse	0-300 kmole/hr
FCR	Col.3 reflux flowrate	Col.3 reflux valve: V11	0.5	0.3	-	reverse	0-20 kmole/hr
FCB1	Col.1 boil up flowrate	cold inlet valve of R1: V18	0.5	0.3	-	reverse	130-230 kmole/hr
FCB2	Col.2 boil up flowrate	cold inlet valve of R2: V10	0.5	0.3	-	reverse	300-400 kmole/hr
FCB3	Col.3 boil up flowrate	cold inlet valve of R3: V19	0.5	0.3	-	reverse	20-80 kmole/hr
PCG	gas recycle pressure	fresh feed hydrogen valve: V1	2	10	-	reverse	500-700 psi
PC1	Col.1 pressure	Col.1 gas valve: V6	2	10	-	direct	100-200 psi
PC2	Col.2 pressure	Col.2 condenser duty: qc2	2	10	-	direct	20-40 psi
PC3	Col.3 pressure	bypass valve of CR: VBP6	2	10	-	reverse	50-100 psi
TCR	reactor inlet temperature	furnace duty: qfur	0.48	1.64	0.364	reverse	565.56-676.67°C
TC1	Col.1 tray-6 temperature	bypass valve of R1: VBP4	5.64	1.30	0.288	direct	100-200°C
TC2	Col.2 tray-12 temperature	auxiliary reboiler2 duty: qar2	2.00	8.00	0.16	reverse	93.33-148.89°C
TC3	Avg. temp. of Col.3 Tray 1, 2, 3 and 4	bypass valve of R3: VBP3	4.00	10	-	direct	275-375°C
TCQ	quenched temperature	quench valve: V13	1.22	3.85	0.856	direct	565.56-676.67°C
TCS	separator temperature	cooler duty: qcooler	1.64	0.33	0.0732	direct	30-100°C
TCE2h	hot outlet temp. of FEHE2	bypass valve of FEHE2: VBP1	11.5	0.934	0.207	reverse	300-400°C
TCE3h	hot outlet temp. of FEHE3	bypass valve of FEHE3: VBP2	9.93	0.593	0.132	reverse	400-500°C
LC11	Col.1 base level	Col.2 feed valve: V7	2	-	-	direct	0-100 %
LC12	Col.1 reflux drum level	Col.1 condenser duty: qc1	2	-	-	reverse	0-100 %
LC21	Col.2 base level	Col.3 feed valve: V9	2	-	-	direct	0-100 %
LC22	Col.2 reflux drum level	Col.2 product valve: V8	2	-	-	direct	0-100 %
LC31	Col.3 base level	Col.3 bottom valve: V12	2	-	-	direct	0-100 %
LC32	Col.3 reflux drum level	toluene recycle valve: V3	2	-	-	direct	0-100 %
LCS	Separator liquid level	Col.1 feed valve: V5	2	-	-	direct	0-100 %
CCG	Methane in gas recycle	purge valve: V4	0.2	15	-	direct	0-100 %

Table C.6 parameter tuning of the CS1 of HDA with minimum auxiliary reboilers

Controller	Controlled variable	Manipulated variable	Tuning parameter			Control action	PV range
			Kc	τ_I	τ_D		
FCtol	total toluene flowrate	fresh feed toluene valve: V2	0.5	0.3	-	reverse	0-300 kmole/hr
FCR	Col.3 reflux flowrate	Col.3 reflux valve: V11	0.5	0.3	-	reverse	0-20 kmole/hr
FCB1	Col.1 boil up flowrate	cold inlet valve of R1: V18	0.5	0.3	-	reverse	130-230 kmole/hr
FCB2	Col.2 boil up flowrate	cold inlet valve of R2: V10	0.5	0.3	-	reverse	300-400 kmole/hr
FCB3	Col.3 boil up flowrate	cold inlet valve of R3: V19	0.5	0.3	-	reverse	20-80 kmole/hr
PCG	gas recycle pressure	fresh feed hydrogen valve: V1	2	10	-	reverse	500-700 psi
PC1	Col.1 pressure	Col.1 gas valve: V6	2	10	-	direct	100-200 psi
PC2	Col.2 pressure	Col.2 condenser duty: qc2	2	10	-	direct	20-40 psi
PC3	Col.3 pressure	bypass valve of CR: VBP6	2	10	-	reverse	50-100 psi
TCR	reactor inlet temperature	furnace duty: qfur	0.48	1.64	0.364	reverse	565.56-676.67°C
TC11	Col.1 tray-6 temperature	Col.1 reflux flowrate	6.33	0.0996	0.0221	direct	100-200°C
TC12	Col.1 tray-3 temperature	bypass valve of R1: VBP4	4.38	0.726	0.161	direct	121.11-232.22°C
TC2	Col.2 tray-12 temperature	bypass valve of R2: VBP5	30	5	-	direct	93.33-148.89°C
TC3	Avg. temp. of Col.3 Tray 1, 2, 3 and 4	bypass valve of R3: VBP3	4.00	10	-	direct	275-375°C
TCQ	quenched temperature	quench valve: V13	1.22	3.85	0.856	direct	565.56-676.67°C
TCS	separator temperature	cooler duty: qcooler	1.64	0.33	0.0732	direct	30-100°C
TCE2h	hot outlet temp. of FEHE2	bypass valve of FEHE2: VBP1	11.5	0.934	0.207	reverse	300-400°C
TCE3h	hot outlet temp. of FEHE3	bypass valve of FEHE3: VBP2	9.93	0.593	0.132	reverse	400-500°C
LC11	Col.1 base level	Col.2 feed valve: V7	2	-	-	direct	0-100 %
LC12	Col.1 reflux drum level	Col.1 condenser duty: qc1	2	-	-	reverse	0-100 %
LC21	Col.2 base level	Col.3 feed valve: V9	2	-	-	direct	0-100 %
LC22	Col.2 reflux drum level	Col.2 product valve: V8	2	-	-	direct	0-100 %
LC31	Col.3 base level	Col.3 bottom valve: V12	2	-	-	direct	0-100 %
LC32	Col.3 reflux drum level	toluene recycle valve: V3	2	-	-	direct	0-100 %
LCS	Separator liquid level	Col.1 feed valve: V5	2	-	-	direct	0-100 %
CCG	Methane in gas recycle	purge valve: V4	0.2	15	-	direct	0-100 %

Table C.7 parameter tuning of the CS2 of HDA with three auxiliary reboilers

Controller	Controlled variable	Manipulated variable	Tuning parameter			Control action	PV range
			Kc	τ_I	τ_D		
FCtol	total toluene flowrate	fresh feed toluene valve: V2	0.5	0.3	-	reverse	0-300 kmole/hr
FCR	Col.3 reflux flowrate	Col.3 reflux valve: V11	0.5	0.3	-	reverse	0-20 kmole/hr
FCB1	Col.1 boil up flowrate	cold inlet valve of R1: V18	0.5	0.3	-	reverse	130-230 kmole/hr
FC2	Col.3 feed flowrate	Col.3 feed valve: V9	0.5	0.3	-	reverse	0-80 kmole/hr
FCB3	Col.3 boil up flowrate	cold inlet valve of R3: V19	0.5	0.3	-	reverse	20-80 kmole/hr
PCG	gas recycle pressure	fresh feed hydrogen valve: V1	2	10	-	reverse	500-700 psi
PC1	Col.1 pressure	Col.1 gas valve: V6	2	10	-	direct	100-200 psi
PC2	Col.2 pressure	Col.2 condenser duty: qc2	2	10	-	direct	20-40 psi
PC3	Col.3 pressure	bypass valve of CR: VBP6	2	10	-	reverse	50-100 psi
TCR	reactor inlet temperature	furnace duty: qfur	0.48	1.64	0.364	reverse	565.56-676.67°C
TC11	Col.1 tray-6 temperature	Col.1 reflux flowrate	6.33	0.0996	0.0221	direct	100-200°C
TC12	Col.1 tray-3 temperature	bypass valve of R1: VBP4	4.38	0.726	0.161	direct	121.11-232.22°C
TC2	Col.2 tray-12 temperature	bypass valve of R2: VBP5	30	5	-	direct	93.33-148.89°C
TC3	Avg. temp. of Col.3 Tray 1, 2, 3 and 4	bypass valve of R3: VBP3	4.00	10	-	direct	275-375°C
TCQ	quenched temperature	quench valve: V13	1.22	3.85	0.856	direct	565.56-676.67°C
TCS	separator temperature	cooler duty: qcooler	1.64	0.33	0.0732	direct	30-100°C
TCE2h	hot outlet temp. of FEHE2	bypass valve of FEHE2: VBP1	11.5	0.934	0.207	reverse	300-400°C
TCE3h	hot outlet temp. of FEHE3	bypass valve of FEHE3: VBP2	9.93	0.593	0.132	reverse	400-500°C
LC11	Col.1 base level	Col.2 feed valve: V7	2	-	-	direct	0-100 %
LC12	Col.1 reflux drum level	Col.1 condenser duty: qc1	2	-	-	reverse	0-100 %
LC21	Col.2 base level	cold inlet valve of R2: V10	2	-	-	direct	0-100 %
LC22	Col.2 reflux drum level	Col.2 product valve: V8	2	-	-	direct	0-100 %
LC31	Col.3 base level	Col.3 bottom valve: V12	2	-	-	direct	0-100 %
LC32	Col.3 reflux drum level	toluene recycle valve: V3	2	-	-	direct	0-100 %
LCS	Separator liquid level	Col.1 feed valve: V5	2	-	-	direct	0-100 %
CCG	Methane in gas recycle	purge valve: V4	0.2	15	-	direct	0-100 %

Table C.8 parameter tuning of the CS3 of HDA with three auxiliary reboilers

Controller	Controlled variable	Manipulated variable	Tuning parameter			Control action	PV range
			Kc	τ_I	τ_D		
FCtol	total toluene flowrate	fresh feed toluene valve: V2	0.5	0.3	-	reverse	0-300 kmole/hr
FCR	Col.3 reflux flowrate	Col.3 reflux valve: V11	0.5	0.3	-	reverse	0-20 kmole/hr
FCB1	Col.1 boil up flowrate	cold inlet valve of R1: V18	0.5	0.3	-	reverse	130-230 kmole/hr
FC2	Col.3 feed flowrate	Col.3 feed valve: V9	0.5	0.3	-	reverse	0-80 kmole/hr
FCB3	Col.3 boil up flowrate	cold inlet valve of R3: V19	0.5	0.3	-	reverse	20-80 kmole/hr
PCG	gas recycle pressure	fresh feed hydrogen valve: V1	2	10	-	reverse	500-700 psi
PC1	Col.1 pressure	Col.1 condenser duty: qc1	2	10	-	direct	100-200 psi
PC2	Col.2 pressure	Col.2 condenser duty: qc2	2	10	-	direct	20-40 psi
PC3	Col.3 pressure	bypass valve of CR: VBP6	2	10	-	reverse	50-100 psi
TCR	reactor inlet temperature	furnace duty: qfur	0.48	1.64	0.364	reverse	565.56-676.67°C
TC11	Col.1 tray-6 temperature	Col.1 gas valve: V6	5	2	0.0212	reverse	100-200°C
TC12	Col.1 tray-3 temperature	bypass valve of R1: VBP4	4.38	0.726	0.161	direct	121.11-232.22°C
TC2	Col.2 tray-12 temperature	bypass valve of R2: VBP5	30	5	-	direct	93.33-148.89°C
TC3	Avg. temp. of Col.3 Tray 1, 2, 3 and 4	bypass valve of R3: VBP3	4.00	10	-	direct	275-375°C
TCQ	quenched temperature	quench valve: V13	1.22	3.85	0.856	direct	565.56-676.67°C
TCS	separator temperature	cooler duty: qcooler	1.64	0.33	0.0732	direct	30-100°C
TCE2h	hot outlet temp. of FEHE2	bypass valve of FEHE2: VBP1	11.5	0.934	0.207	reverse	300-400°C
TCE3h	hot outlet temp. of FEHE3	bypass valve of FEHE3: VBP2	9.93	0.593	0.132	reverse	400-500°C
LC11	Col.1 base level	Col.2 feed valve: V7	2	-	-	direct	0-100 %
LC12	Col.1 reflux drum level	Col.1 reflux flowrate	2	-	-	direct	0-100 %
LC21	Col.2 base level	cold inlet valve of R2: V10	2	-	-	direct	0-100 %
LC22	Col.2 reflux drum level	Col.2 product valve: V8	2	-	-	direct	0-100 %
LC31	Col.3 base level	Col.3 bottom valve: V12	2	-	-	direct	0-100 %
LC32	Col.3 reflux drum level	toluene recycle valve: V3	2	-	-	direct	0-100 %
LCS	Separator liquid level	Col.1 feed valve: V5	2	-	-	direct	0-100 %
CCG	Methane in gas recycle	purge valve: V4	0.2	15	-	direct	0-100 %

APPENDIX D

RESULTS OF IAE VALUE

The purpose of this Appendix is to present the results of IAE value of each control structure when all disturbances occur in the process. In this research, since IAE value of tray temperature control of the recycle column is very large when compared to other control loops, so we neglect its value for calculating the total IAE value.

D.1 Control Structure with Three Auxiliary Reboilers

Table D.1 IAE value for Change in the Disturbance Load of Cold Stream.

Controller	Integral Absolute Error (IAE)			
	Base Case	CS1	CS2	CS3
FCtol	7.761	7.457	7.132	7.933
TCR	14.271	13.522	12.756	15.152
TCQ	11.945	11.592	10.911	12.912
TCS	1.229	1.181	1.166	1.203
TC11	1.625	0.374	0.470	2.981
TC12	-	3.286	4.430	4.157
TC2	0.536	0.305	0.357	0.658
TC3	17.888	65.229	7.684	7.953
TCE2h	3.641	3.337	3.236	3.613
TCE3h	5.072	4.775	4.519	5.289
Total	63.967	107.773	48.230	57.693
	46.079	42.544	40.546	49.740

สถาบันวิทยบริการ
จุฬาลงกรณ์มหาวิทยาลัย

Table D.2 IAE value for Change in the Disturbance Load of Cold Stream from the Bottoms of Stabilizer Column.

Controller	Integral Absolute Error (IAE)			
	Base Case	CS1	CS2	CS3
FCtol	2.743	1.660	1.798	2.249
TCR	10.430	6.704	6.471	9.429
TCQ	19.711	6.276	5.144	5.953
TCS	0.190	0.100	0.095	0.127
TC11	1.555	0.918	1.011	6.892
TC12	-	12.185	13.037	13.258
TC2	1.469	2.374	1.911	3.608
TC3	28.516	187.660	11.448	10.099
TCE2h	2.107	2.085	1.725	2.596
TCE3h	2.220	1.540	1.527	1.945
Total	68.941	221.501	44.167	56.156
	40.425	33.841	32.719	46.057

Table D.3 IAE value for Change in the Disturbance Load of Cold Stream from the Bottoms of Product Column.

Controller	Integral Absolute Error (IAE)			
	Base Case	CS1	CS2	CS3
FCtol	1.934	2.175	2.180	1.967
TCR	17.742	8.028	8.953	8.043
TCQ	12.596	9.832	8.497	9.090
TCS	0.154	0.133	0.118	0.120
TC11	0.301	0.215	0.281	1.717
TC12	-	2.021	2.245	2.307
TC2	2.405	3.876	0.772	3.679
TC3	193.610	4741.900	2949.500	4026
TCE2h	2.592	1.743	1.874	1.683
TCE3h	1.726	1.582	1.294	1.392
Total	233.033	4771.504	2975.715	4055.998
	39.423	29.604	26.215	29.998

Table D.4 IAE value for Change in the Disturbance Load of Cold Stream from the Bottoms of Recycle Column.

Controller	Integral Absolute Error (IAE)			
	Base Case	CS1	CS2	CS3
FCtol	1.469	2.277	1.836	2.063
TCR	7.950	3.642	3.725	4.531
TCQ	8.300	7.452	5.745	6.576
TCS	0.169	0.122	0.104	0.114
TC11	0.161	0.219	0.155	0.699
TC12	-	2.163	1.535	1.461
TC2	0.473	0.409	1.749	1.685
TC3	190.760	2408.200	3164.300	3067.800
TCE2h	1.099	1.509	1.347	1.497
TCE3h	1.069	1.172	1.079	1.394
Total	211.450	2427.164	3181.575	3087.820
	20.690	18.964	17.275	20.020

Table D.5 IAE value for Change in the Disturbance Load of Hot Stream.

Controller	Integral Absolute Error (IAE)			
	Base Case	CS1	CS2	CS3
FCtol	13.512	13.494	11.571	10.983
TCR	44.774	44.753	39.964	39.159
TCQ	37.455	30.892	26.798	28.398
TCS	0.912	0.722	0.628	0.592
TC11	2.420	9.455	0.971	1.022
TC12	-	15.022	9.809	10.549
TC2	6.875	3.672	2.744	2.811
TC3	233.465	155.260	166.400	709.770
TCE2h	6.234	7.209	5.967	6.055
TCE3h	37.942	30.581	35.201	49.187
Total	383.589	311.060	300.053	858.526
	150.124	155.800	133.653	148.756

Table D.6 IAE value for Change in the Total Toluene Feed Flowrate.

Controller	Integral Absolute Error (IAE)			
	Base Case	CS1	CS2	CS3
FCtol	4.900	3.666	3.833	3.987
TCR	376.090	158.190	161.170	186.620
TCQ	518.690	153.700	152.140	172.270
TCS	5.431	3.281	3.710	3.988
TC11	23.505	3.710	5.827	56.153
TC12	-	70.276	73.066	90.898
TC2	24.110	16.834	12.685	15.867
TC3	2133.100	4528.300	330.660	322.300
TCE2h	65.884	29.204	27.779	31.428
TCE3h	134.010	53.911	55.004	62.665
Total	3285.720	4952.573	752.808	855.278
	1152.620	424.273	422.148	532.978

D.2 Control Structure with Minimum Auxiliary Reboilers

Table D.7 IAE value for Change in the Disturbance Load of Cold Stream.

Controller	Integral Absolute Error (IAE)			
	Base Case	CS1	CS2	CS3
FCtol	6.341	4.740	4.981	5.290
TCR	10.097	9.927	6.149	7.215
TCQ	8.521	9.532	10.911	6.198
TCS	1.256	1.033	1.166	1.059
TC11	4.028	0.261	0.265	2.522
TC12	-	2.106	2.094	3.652
TC2	0.359	0.295	0.189	0.372
TC3	74.411	55.668	5.893	6.245
TCE2h	3.986	1.854	2.011	2.193
TCE3h	3.934	2.047	2.382	2.733
Total	112.933	85.357	28.264	33.826
	38.522	29.689	22.371	27.581

Table D.8 IAE value for Change in the Disturbance Load of Cold Stream from the Bottoms of Stabilizer Column.

Controller	Integral Absolute Error (IAE)			
	Base Case	CS1	CS2	CS3
FCtol	3.247	2.236	2.236	2.429
TCR	11.315	11.104	9.859	10.339
TCQ	12.621	9.727	6.454	6.784
TCS	0.251	0.126	0.113	0.132
TC11	31.241	0.346	0.347	4.612
TC12	-	12.584	12.423	12.702
TC2	3.692	4.381	3.683	3.566
TC3	314.040	349.750	24.642	24.263
TCE2h	3.639	3.243	2.506	2.631
TCE3h	2.717	2.237	2.055	2.330
Total	382.765	395.733	64.317	69.788
	68.725	45.983	39.675	45.525

Table D.9 IAE value for Change in the Disturbance Load of Cold Stream from the Bottoms of Product Column.

Controller	Integral Absolute Error (IAE)			
	Base Case	CS1	CS2	CS3
FCtol	2.264	5.496	3.454	4.985
TCR	15.527	16.043	11.390	14.213
TCQ	13.272	13.818	11.000	12.387
TCS	0.139	0.301	0.193	0.274
TC11	3.553	1.824	0.176	0.266
TC12	-	1.928	1.846	1.846
TC2	4.367	4.827	0.701	4.751
TC3	2351.403	5620.500	2042.000	5536.000
TCE2h	1.965	3.041	2.073	2.635
TCE3h	1.413	4.511	2.726	4.001
Total	2393.903	5672.288	2075.559	5581.855
	42.500	51.788	33.559	45.855

Table D.10 IAE value for Change in the Disturbance Load of Cold Stream from the Bottoms of Recycle Column.

Controller	Integral Absolute Error (IAE)			
	Base Case	CS1	CS2	CS3
FCtol	1.137	1.057	0.921	1.873
TCR	3.229	3.361	2.919	4.319
TCQ	7.493	7.367	7.264	7.863
TCS	0.032	0.040	0.030	0.113
TC11	0.533	0.534	0.023	0.037
TC12	-	0.736	0.631	0.933
TC2	1.588	1.612	0.209	1.564
TC3	1219.709	2362.300	1172.300	2315.700
TCE2h	1.553	1.473	1.316	1.601
TCE3h	0.876	0.736	0.801	1.305
Total	1236.150	2379.388	1186.412	2335.307
	16.441	17.088	14.112	19.607

Table D.11 IAE value for Change in the Disturbance Load of Hot Stream.

Controller	Integral Absolute Error (IAE)			
	Base Case	CS1	CS2	CS3
FCtol	19.561	14.278	16.313	20.088
TCR	59.995	57.332	50.541	60.532
TCQ	48.229	46.187	36.948	45.360
TCS	0.557	0.822	0.933	1.144
TC11	17.173	0.947	1.053	8.240
TC12	-	7.780	8.278	11.185
TC2	6.966	3.074	3.107	3.717
TC3	710.799	708.451	157.360	157.160
TCE2h	9.465	8.229	8.122	10.044
TCE3h	17.112	18.498	14.519	17.882
Total	889.856	865.597	296.992	335.352
	179.057	157.146	139.632	178.192

Table D.12 IAE value for Change in the Total Toluene Feed Flowrate.

Controller	Integral Absolute Error (IAE)			
	Base Case	CS1	CS2	CS3
FCtol	3.360	4.026	3.796	3.569
TCR	174.140	193.720	167.770	153.160
TCQ	184.440	180.820	159.120	160.900
TCS	4.109	4.109	3.772	2.835
TC11	176.030	65.076	4.913	10.337
TC12	-	99.640	57.916	61.028
TC2	27.969	15.537	12.397	21.330
TC3	4378.782	275.870	273.250	4321.500
TCE2h	31.444	31.089	26.712	30.318
TCE3h	50.927	62.446	54.373	50.776
Total	5030.057	932.333	764.019	4815.753
	651.275	656.463	490.769	494.253



สถาบันวิทยบริการ
จุฬาลงกรณ์มหาวิทยาลัย

VITA

Mr. Boonlert Sae-leaw was born in Satun on December 15, 1982. He graduated Bachelor Degree in Chemical Engineering from Prince of Songkla University in 2005. After that he studied for Master Degree in Chemical Engineering at Chulalongkorn University.



สถาบันวิทยบริการ
จุฬาลงกรณ์มหาวิทยาลัย