

การออกแบบและควบคุมโรงงานไฮโดรดิอัลคิเลชั่น
ที่มีการเบ็ดเสร็จทางด้านความร้อนที่ซับซ้อน



นางสาวสุมาลี เหมนิธิ

ศูนย์วิทยทรัพยากร
วิทยานิพนธ์นี้เป็นส่วนหนึ่งของการศึกษาตามหลักสูตรปริญญาวิศวกรรมศาสตรมหาบัณฑิต

สาขาวิชาวิศวกรรมเคมี ภาควิชาวิศวกรรมเคมี
คณะวิศวกรรมศาสตร์ จุฬาลงกรณ์มหาวิทยาลัย

ปีการศึกษา 2552

ลิขสิทธิ์ของจุฬาลงกรณ์มหาวิทยาลัย

DESIGN AND CONTROL OF COMPLEX
HEAT INTEGRATED HDA PLANT



Miss. Sumalee Hemnithi

A Thesis Submitted in Partial Fulfillment of the Requirements
for the Degree of Master of Engineering Program in Chemical Engineering

Department of Chemical Engineering

Faculty of Engineering

Chulalongkorn University

Academic Year 2009

Copyright of Chulalongkorn University

Thesis Title DESIGN AND CONTROL OF COMPLEX
HEAT INTEGRATED HDA PLANT
By Miss. Sumalee Hemnithi
Field of Study Chemical Engineering
Thesis Advisor Assistant Professor Montree Wongsri, D.Sc

Accepted by the Faculty of Engineering, Chulalongkorn University in Partial
Fulfillment of the Requirements for the Master's Degree

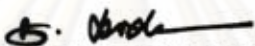
..... Dean of the Faculty of Engineering
(Associate Professor Boonsom Lerdhirunwong, Dr.Ing.)

THESIS COMMITTEE

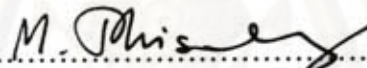
..... Chairperson
(Associate Professor Muenduen Phisalaphong, Ph.D.)

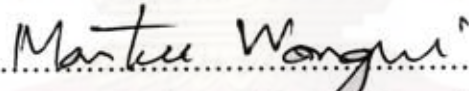
..... Thesis Advisor
(Assistant Professor Montree Wongsri, D.Sc.)

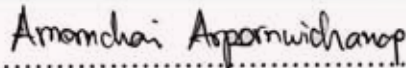
..... Examiner
(Assistant Professor Amornchai Arpornwichanop, D.Eng.)

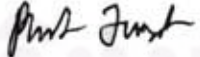
..... External Examiner
(Phisit Jaisathaporn, Ph.D.)

ศูนย์วิจัยและพัฒนา
จุฬาลงกรณ์มหาวิทยาลัย

สุมาลี เหมนิธิ: การออกแบบและควบคุมโรงงานไฮโดรคิออลิเลชันที่มีการเบ็ดเสร็จทางด้านความร้อนที่ซับซ้อน. (DESIGN AND CONTROL OF COMPLEX HEAT INTEGRATED HDA PLANT) อ.ที่ปรึกษาวิทยานิพนธ์หลัก: ผศ. ดร. มนตรี วงศ์ศรี, 214 หน้า.

ในงานวิจัยนี้ได้ทำการออกแบบข้างงานเครื่องแลกเปลี่ยนความร้อนของกระบวนการไฮโดรคิออลิเลชันที่มีโครงสร้างในส่วนของกรอกสารแบบใหม่ โดยมีจุดประสงค์เพื่อลดการใช้พลังงานของหน่วยปฏิบัติการในกระบวนการ นอกจากนี้ยังได้มีการออกแบบโครงสร้างการควบคุมแบบแพลนท์ไวด์สำหรับกระบวนการดังกล่าวซึ่งเป็นกระบวนการที่มีการเบ็ดเสร็จพลังงานอย่างซับซ้อน การออกแบบโครงสร้างการควบคุมถูกออกแบบโดยการใช้วิธีการส่งผ่านความแปรปรวนของ (Wongsri, M., 1990) และการออกแบบเส้นทางเดินของความร้อน (heat pathway heuristics) ของ (Wongsri, M. and Hermawan Y.D., 2005) ตามลำดับ ในการประเมินสมรรถนะโครงสร้างการควบคุมได้ใช้ตัวบวกรกระบวนการ 2 ชนิด ได้แก่ การรบกวนทางความร้อนและการรบกวนอัตราสารไหลของสาร การประเมินสมรรถนะกระบวนการที่มีการเบ็ดเสร็จทางด้านพลังงานที่ซับซ้อนและโครงสร้างการควบคุมที่สถานะเชิงพลวัตสามารถทำได้โดยการจำลองกระบวนการด้วยโปรแกรมไฮซีส

ภาควิชา.....วิศวกรรมเคมี.....
สาขาวิชา.....วิศวกรรมเคมี.....
ปีการศึกษา.....2552.....

ลายมือชื่อนิสิต.....สุมาลี เหมนิธิ.....
ลายมือชื่ออ.ที่ปรึกษาวิทยานิพนธ์หลัก.....

ศูนย์วิทยทรัพยากร
จุฬาลงกรณ์มหาวิทยาลัย

4970655521 : MAJOR CHEMICAL ENGINEERING

KEYWORDS : HEAT EXCHANGER NETWORK / HDA PROCESS / PLANTWIDE
PROCESS CONTROL / HEAT INTEGRATED PROCESS

SUMALEE HEMNITHI: DESIGN AND CONTROL OF COMPLEX HEAT
INTEGRATED HDA PLANT. THESIS ADVISOR: ASST. PROF. MONTREE
WONGSRI, D.Sc., 214 pp.

In this research, we design the heat exchanger network (HEN) of HDA processes which are consists of the new separation section to save energy usage of utilities in the process. Furthermore, the plantwide control structures for this process which is the complex heat-integrated process are designed. The plantwide control structures are designed by using the disturbance load propagation method (Wongsri, M., 1990) and heat pathway heuristics (Wongsri, M. and Hermawan Y.D., 2005), respectively. Two kinds of disturbances: thermal and material disturbances are used in evaluation of the plantwide control structures. The performances of the heat integrated plants (HIPs) and the control structures are evaluated dynamically by the commercial software HYSYS.

Department :...Chemical Engineering... Student's signature... Sumalee Hemnithi...
Field of study : Chemical Engineering... Advisor's signature... Montree Wongsri...
Academic year :.....2009.....

ACKNOWLEDGEMENTS

First and foremost, I would like to express my most sincere thanks to my advisor, Assistant Professor Montree Wongsri, for his great guidance and insightful comments. Under his supervision, I learned a lot of process control and techniques, as well as the heuristic approach for control design. It has been a great opportunity and experience for me to work in his group. Special thanks belong to Associate Professor Muenduen Phisalaphong, Assistant Professor Amornchai Arpornwichanop and Dr. Pisit Jaisathaporn for kindly serving as my committee members.

I owe special thanks to the whole students of Control and Systems Engineering Laboratory (CASE) for the good spirit shared, supports and wonderful times we have had over the years.

Finally, I would like to dedicate this dissertation to my family for their edification, inspiration, encouragement and endless love. Without them, I would not have been the person I am and certainly this work would never have reached completion.



ศูนย์วิทยทรัพยากร
จุฬาลงกรณ์มหาวิทยาลัย

CONTENTS

PAGE

ABSTRACT IN THAI	iv
ABSTRACT IN ENGLISH	v
ACKNOWLEDGEMENTS	vi
CONTENTS	vii
LIST OF TABLES	ix
LIST OF FIGURES	xii
NOMENCLATURES	xxiv

CHAPTER

I INTRODUCTION	1
1.1 Importance and Reasons for Research	1
1.2 Objectives of the Research.....	2
1.3 Scopes of the Research	3
1.4 Contributions of the Research.....	3
1.5 Research Methodology	3
1.6 Research Contents.....	4
II LITERATURE REVIEWS	5
2.1 A Hierarchical Approach to Conceptual Design	5
2.2 Heat Exchanger Networks (HENs).....	7
2.3 Design and Control of Energy-Integrated Plants	11
III PLANTWIDE CONTROL FUNDAMENTALS	15
3.1 Incentives for Chemical Process Control.....	15
3.2 Integrated Processes	16
3.3 Basic Concepts of Plantwide Control	18
3.4 Plantwide Control Design Procedure.....	21
3.5 Plantwide Energy Management	25
3.6 Control of Process-to-Process Exchangers	28
IV TYPICAL HDA PROCESS	31
4.1 Process Description.....	31
4.2 Alternatives of the Typical HDA Processes	33
4.3 Design of Heat Exchanger Networks of Typical HDA Processes.....	33
4.4 Steady State Model of the Typical HDA Processes.....	41
4.5 Energy Comparison of the Typical HDA Processes.....	46

CHAPTER	PAGE
V THE NEW COMPLEX HEAT-INTEGRATED STRUCTURES FOR HDA PROCESS.....	47
5.1 Design of the Complex Heat-Integrated HDA Plant	47
5.2 Design of Resilient Heat Exchanger Networks (RHEN) for Complex Heat-Integrated HDA Plant	48
5.3 Complex Heat-Integration Structures of HDA Process	55
5.4 Steady State Model of Complex Heat-Integrated HDA Plant	59
5.5 Energy Comparisons of Complex Heat-Integrated HAD Plant	66
VI CONTROL STRUCTURES AND DYNAMIC SIMULATION.....	68
6.1 Plantwide Control Strategies.....	68
6.2 Energy Management of Heat-Integrated Process.....	72
6.3 Design of Plantwide Control Structure of HDA Process.....	89
6.4 Dynamic Simulation Results.....	120
6.5 Dynamic Simulation Results of Typical HDA Process	120
6.6 Dynamic Simulation Results of Complex Heat-Integrated HDA Process.....	145
6.7 Evaluation of the Dynamic Performance	196
VII CONCLUSIONS AND RECOMMENDATIONS.....	200
7.1 Conclusion	200
7.2 Recommendation	201
REFERENCES.....	202
APPENDICES.....	204
Appendix A	205
Appendix B	211
VITA	214

LIST OF TABLES

	PAGE
Table 4.1	The energy saving from the energy integration of Typical HDA process 33
Table 4.2	The information of the typical HDA process 35
Table 4.3	Problem table for alternative 5 36
Table 4.4	Synthesis table for cold end of alternative 5 36
Table 4.5	Synthesis table for hot end of alternative 5 36
Table 4.6	Problem table for alternative 6 38
Table 4.7	Synthesis table for cold end of alternative 6 38
Table 4.8	Synthesis table for hot end of alternative 6 38
Table 4.9	Energy savings of the typical HDA process (steady state simulation) 46
Table 5.1	The information of complex heat-integrated plant (HIP) of HDA process 48
Table 5.2	Problem table for HIP5 48
Table 5.3	Synthesis table for cold end of HIP5.1 and 5.2 49
Table 5.4	Synthesis table for hot end of HIP5.1 49
Table 5.5	Synthesis table for hot end of HIP5.2 50
Table 5.6	Problem table for HIP6 51
Table 5.7	Synthesis table for cold end of HIP6.1, 6.2 and 6.3 52
Table 5.8	Synthesis table for hot end of HIP6.1 52
Table 5.9	Synthesis table for hot end of HIP6.2 53
Table 5.10	Synthesis table for hot end of HIP6.3 53
Table 5.11	Energy savings of the heat-integrated HDA plant (steady state simulation) 66
Table 5.12	Energy savings of the heat-integrated plant of HDA process compared with the typical HDA process (steady state simulation) 67
Table 6.1	Controller parameters for the complex heat-integrated typical HDA process Alternative 5 (HIP5.0): CS1, CS2 and CS3 92

Table 6.2	Controller parameters for the complex heat-integrated typical HDA process Alternative 6 (HIP6.0): CS1, CS2 and CS3.....	97
Table 6.3	Controller parameters for the complex heat-integrated HDA process HIP5 (Both HIP5.1 and 5.2): CS1, CS2 and CS3	102
Table 6.4	Controller parameters for the complex heat-integrated HDA process HIP6 (HIP6.1, 6.2 and 6.3): CS1, CS2 and CS3	110
Table 6.5a	The IAE Values of the complex heat-integrated typical HDA process alternative 5 (HIP5.0) and complex heat-Integrated HDA HIP5 (Both HIP5.1 and 5.2) to a change in the disturbance load of cold streams (reactor feed stream)	197
Table 6.5b	The IAE Values of the complex heat-integrated typical HDA process alternative 5 (HIP5.0) and complex heat-Integrated HDA HIP5 (Both HIP5.1 and 5.2) to a change in the disturbance load of hot streams (reactor product stream).....	197
Table 6.5c	The IAE Values of the complex heat-integrated typical HDA process alternative 5 (HIP5.0) and complex heat-Integrated HDA HIP5 (Both HIP5.1 and 5.2) to a change in the disturbance load of total toluene feed flowrates	198
Table 6.6a	The IAE Values of the complex heat-integrated typical HDA process alternative 6 (HIP6.0) and complex heat-Integrated HDA HIP5 (HIP6.1, 6.2 and 6.3) to a change in the disturbance load of cold streams (reactor feed stream)	198
Table 6.6b	The IAE Values of the complex heat-integrated typical HDA process alternative 6 (HIP6.0) and complex heat-Integrated HDA HIP5 (HIP6.1, 6.2 and 6.3) to a change in the disturbance load of hot streams (reactor product stream).....	199
Table 6.6c	The IAE Values of the complex heat-integrated typical HDA process alternative 6 (HIP6.0) and complex heat-Integrated HDA HIP5 (HIP6.1, 6.2 and 6.3) to a change in the disturbance load of total toluene feed flowrates	199
Table A.1	Process stream data for complex heat-integrated HDA plant HIP5....	205

Table A.2	Process stream data for complex heat-integrated HDA plant HIP6....	208
Table B.1	Equipment data and specifications of complex heat-integrated HDA plant	211
Table B.2	Column Specifications of the typical HDA plant alternative 5 compared with the complex heat-integrated HDA plant HIP5	212
Table B.3	Column Specifications of the typical HDA plant alternative 6 compared with the complex heat-integrated HDA plant HIP6	213

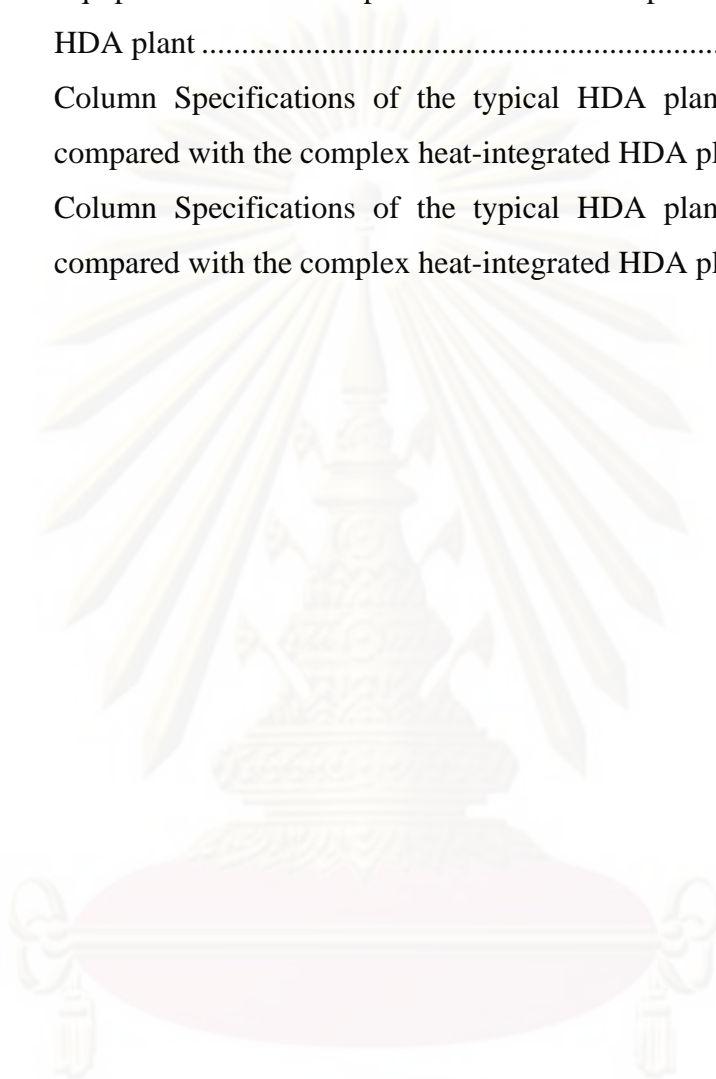

ศูนย์วิทยทรัพยากร
จุฬาลงกรณ์มหาวิทยาลัย

LIST OF FIGURES

		PAGE
Figure 3.1	Heat pathways	27
Figure 3.2	Bypass controls of process-to-process heat exchangers.....	29
Figure 3.3	Control of process-to-process heat exchanger using the auxiliary utility	30
Figure 4.1	Hydrodealkylation (HDA) of toluene process	32
Figure 4.2	The six alternatives of the typical HDA process structures	34
Figure 4.3	The resilient heat exchanger network alternative 5.....	35
Figure 4.4	The resilient heat exchanger network alternative 6.....	37
Figure 4.5	The typical HDA process alternative 1 (Base case).....	40
Figure 4.6	The typical HDA process alternative 5	40
Figure 4.7	The typical HDA process alternative 6	41
Figure 4.8	HYSYS flowsheet of the steady state model for the simply heat- integrated typical HDA process Alternative 1 (Base case).....	43
Figure 4.9	HYSYS flowsheet of the steady state model for the complex heat- integrated typical HDA process Alternative 5	44
Figure 4.10	HYSYS flowsheet of the steady state model for the complex heat- integrated typical HDA process Alternative 6	45
Figure 5.1	Separation section in the complex heat-integrated structure.....	47
Figure 5.2	The resilient heat exchanger network HIP5.1	50
Figure 5.3	The resilient heat exchanger network HIP5.2	51
Figure 5.4	The resilient heat exchanger network HIP6.1	54
Figure 5.5	The resilient heat exchanger network HIP6.2	55

Figure 5.6	The resilient heat exchanger network HIP6.3	55
Figure 5.7	The heat-integrated structure of HDA process, HIP1	56
Figure 5.8	The heat-integrated structure of HDA process, HIP5.1	56
Figure 5.9	The heat-integrated structure of HDA process, HIP5.2	57
Figure 5.10	The heat-integrated structure of HDA process, HIP6.1	57
Figure 5.11	The heat-integrated structure of HDA process, HIP6.2	58
Figure 5.12	The heat-integrated structure of HDA process, HIP6.3	58
Figure 5.13	HYSYS flowsheet of the steady state model for the simply heat-integrated typical HDA plant HIP1	60
Figure 5.14	HYSYS flowsheet of the steady state model for the complex heat-integrated typical HDA plant HIP5.1	61
Figure 5.15	HYSYS flowsheet of the steady state model for the complex heat-integrated typical HDA plant HIP5.2.....	62
Figure 5.16	HYSYS flowsheet of the steady state model for the complex heat-integrated typical HDA plant HIP6.1	63
Figure 5.17	HYSYS flowsheet of the steady state model for the complex heat-integrated typical HDA plant HIP6.2.....	64
Figure 5.18	HYSYS flowsheet of the steady state model for the complex heat-integrated typical HDA plant HIP6.3.....	65
Figure 6.1	Heat pathways of the typical HDA process alternative 5 (HIP5.0)	74
Figure 6.2	Control configurations of alternative 5 (HIP5.0)	75
Figure 6.3	Heat pathways of the typical HDA process alternative 6 (HIP6.0)	77
Figure 6.4	Control configurations of alternative 6 (HIP6.0)	78

	PAGE
Figure 6.5 Heat pathways of HIP5.1	79
Figure 6.6 Control configurations of HIP5.1	80
Figure 6.7 Heat pathways of HIP5.2	81
Figure 6.8 Control configurations of HIP5.2	82
Figure 6.9 Heat pathways of HIP6.1	83
Figure 6.10 Control configurations of HIP6.1	84
Figure 6.11 Heat pathways of HIP6.2	85
Figure 6.12 Control configurations of HIP6.2	87
Figure 6.13 Heat pathways of HIP6.3	88
Figure 6.14 Control configurations of HIP6.3	89
Figure 6.15 Control structure 1 (CS1) of the complex heat-integrated typical HDA process alternative 5	93
Figure 6.16 Control structure 2 (CS2) of the complex heat-integrated typical HDA process alternative 5	94
Figure 6.17 Control structure 3 (CS3) of the complex heat-integrated typical HDA process alternative 5	95
Figure 6.18 Control structure 1 (CS1) of the complex heat-integrated typical HDA process alternative 6	98
Figure 6.19 Control structure 2 (CS2) of the complex heat-integrated typical HDA process alternative 6	99
Figure 6.20 Control structure 3 (CS3) of the complex heat-integrated typical HDA process alternative 6	100

Figure 6.21	Control structure 1 (CS1) of the complex heat-integrated HDA process HIP5.1	103
Figure 6.22	Control structure 2 (CS2) of the complex heat-integrated HDA process HIP5.1	104
Figure 6.23	Control structure 3 (CS3) of the complex heat-integrated HDA process HIP5.1	105
Figure 6.24	Control structure 1 (CS1) of the complex heat-integrated HDA process HIP5.2	106
Figure 6.25	Control structure 2 (CS2) of the complex heat-integrated HDA process HIP5.2	107
Figure 6.26	Control structure 3 (CS3) of the complex heat-integrated HDA process HIP5.2	108
Figure 6.27	Control structure 1 (CS1) of the complex heat-integrated HDA process HIP6.1	111
Figure 6.28	Control structure 2 (CS2) of the complex heat-integrated HDA process HIP6.1	112
Figure 6.29	Control structure 3 (CS3) of the complex heat-integrated HDA process HIP6.1	113
Figure 6.30	Control structure 1 (CS1) of the complex heat-integrated HDA process HIP6.2	114
Figure 6.31	Control structure 2 (CS2) of the complex heat-integrated HDA process HIP6.2	115

Figure 6.32	Control structure 3 (CS3) of the complex heat-integrated HDA process HIP6.2	116
Figure 6.33	Control structure 1 (CS1) of the complex heat-integrated HDA process HIP6.3	117
Figure 6.34	Control structure 2 (CS2) of the complex heat-integrated HDA process HIP6.3	118
Figure 6.35	Control structure 3 (CS3) of the complex heat-integrated HDA process HIP6.3	119
Figure 6.36	Dynamic responses of the typical HDA process alternative 5 (HIP5.0) to a change in the heat load disturbance of cold streams (reactor feed stream): CS1.....	124
Figure 6.37	Dynamic responses of the typical HDA process alternative 5 (HIP5.0) to a change in the heat load disturbance of hot streams (reactor product stream): CS1.....	125
Figure 6.38	Dynamic responses of the typical HDA process alternative 5 (HIP5.0) to a change in the total toluene feed flowrates: CS1.....	126
Figure 6.39	Dynamic responses of the typical HDA process alternative 5 (HIP5.0) to a change in the heat load disturbance of cold streams (reactor feed stream): CS2.....	127
Figure 6.40	Dynamic responses of the typical HDA process alternative 5 (HIP5.0) to a change in the heat load disturbance of hot streams (reactor product stream): CS2.....	128
Figure 6.41	Dynamic responses of the typical HDA process alternative 5 (HIP5.0) to a change in the total toluene feed flowrates: CS2.....	129

Figure 6.42	Dynamic responses of the typical HDA process alternative 5 (HIP5.0) to a change in the heat load disturbance of cold streams (reactor feed stream): CS3.....	130
Figure 6.43	Dynamic responses of the typical HDA process alternative 5 (HIP5.0) to a change in the heat load disturbance of hot streams (reactor product stream): CS3.....	131
Figure 6.44	Dynamic responses of the typical HDA process alternative 5 (HIP5.0) to a change in the total toluene feed flowrates: CS3.....	132
Figure 6.45	Dynamic responses of the typical HDA process alternative 6 (HIP6.0) to a change in the heat load disturbance of cold streams (reactor feed stream): CS1.....	136
Figure 6.46	Dynamic responses of the typical HDA process alternative 6 (HIP6.0) to a change in the heat load disturbance of hot streams (reactor product stream): CS1.....	137
Figure 6.47	Dynamic responses of the typical HDA process alternative 6 (HIP6.0) to a change in the total toluene feed flowrates: CS1.....	138
Figure 6.48	Dynamic responses of the typical HDA process alternative 6 (HIP6.0) to a change in the heat load disturbance of cold streams (reactor feed stream): CS2.....	139
Figure 6.49	Dynamic responses of the typical HDA process alternative 6 (HIP6.0) to a change in the heat load disturbance of hot streams (reactor product stream): CS2.....	140
Figure 6.50	Dynamic responses of the typical HDA process alternative 6 (HIP6.0) to a change in the total toluene feed flowrates: CS2.....	141

Figure 6.51	Dynamic responses of the typical HDA process alternative 6 (HIP6.0) to a change in the heat load disturbance of cold streams (reactor feed stream): CS3.....	142
Figure 6.52	Dynamic responses of the typical HDA process alternative 6 (HIP6.0) to a change in the heat load disturbance of hot streams (reactor product stream): CS3.....	143
Figure 6.53	Dynamic responses of the typical HDA process alternative 6 (HIP6.0) to a change in the total toluene feed flowrates: CS3.....	144
Figure 6.54	Dynamic responses of the HDA process HIP5.1 to a change in the heat load disturbance of cold streams (reactor feed stream): CS1.....	148
Figure 6.55	Dynamic responses of the HDA process HIP5.1 to a change in the heat load disturbance of hot streams (reactor product stream): CS1	149
Figure 6.56	Dynamic responses of the HDA process HIP5.1 to a change in the total toluene feed flowrates: CS1	150
Figure 6.57	Dynamic responses of the HDA process HIP5.1 to a change in the heat load disturbance of cold streams (reactor feed stream): CS2.....	151
Figure 6.58	Dynamic responses of the HDA process HIP5.1 to a change in the heat load disturbance of hot streams (reactor product stream): CS2	152
Figure 6.59	Dynamic responses of the HDA process HIP5.1 to a change in the total toluene feed flowrates: CS2	153
Figure 6.60	Dynamic responses of the HDA process HIP5.1 to a change in the heat load disturbance of cold streams (reactor feed stream): CS3.....	154
Figure 6.61	Dynamic responses of the HDA process HIP5.1 to a change in the heat load disturbance of hot streams (reactor product stream): CS3	155

Figure 6.62	Dynamic responses of the HDA process HIP5.1 to a change in the total toluene feed flowrates: CS3	156
Figure 6.63	Dynamic responses of the HDA process HIP5.2 to a change in the heat load disturbance of cold streams (reactor feed stream): CS1.....	157
Figure 6.64	Dynamic responses of the HDA process HIP5.2 to a change in the heat load disturbance of hot streams (reactor product stream): CS1	158
Figure 6.65	Dynamic responses of the HDA process HIP5.2 to a change in the total toluene feed flowrates: CS1	159
Figure 6.66	Dynamic responses of the HDA process HIP5.2 to a change in the heat load disturbance of cold streams (reactor feed stream): CS2.....	160
Figure 6.67	Dynamic responses of the HDA process HIP5.2 to a change in the heat load disturbance of hot streams (reactor product stream): CS2	161
Figure 6.68	Dynamic responses of the HDA process HIP5.2 to a change in the total toluene feed flowrates: CS2	162
Figure 6.69	Dynamic responses of the HDA process HIP5.2 to a change in the heat load disturbance of cold streams (reactor feed stream): CS3.....	163
Figure 6.70	Dynamic responses of the HDA process HIP5.2 to a change in the heat load disturbance of hot streams (reactor product stream): CS3	164
Figure 6.71	Dynamic responses of the HDA process HIP5.2 to a change in the total toluene feed flowrates: CS3	165
Figure 6.72	Dynamic responses of the HDA process HIP6.1 to a change in the heat load disturbance of cold streams (reactor feed stream): CS1.....	169

Figure 6.73	Dynamic responses of the HDA process HIP6.1 to a change in the heat load disturbance of hot streams (reactor product stream): CS1	170
Figure 6.74	Dynamic responses of the HDA process HIP6.1 to a change in the total toluene feed flowrates: CS1	171
Figure 6.75	Dynamic responses of the HDA process HIP6.1 to a change in the heat load disturbance of cold streams (reactor feed stream): CS2.....	172
Figure 6.76	Dynamic responses of the HDA process HIP6.1 to a change in the heat load disturbance of hot streams (reactor product stream): CS2	173
Figure 6.77	Dynamic responses of the HDA process HIP6.1 to a change in the total toluene feed flowrates: CS2.....	174
Figure 6.78	Dynamic responses of the HDA process HIP6.1 to a change in the heat load disturbance of cold streams (reactor feed stream): CS3.....	175
Figure 6.79	Dynamic responses of the HDA process HIP6.1 to a change in the heat load disturbance of hot streams (reactor product stream): CS3	176
Figure 6.80	Dynamic responses of the HDA process HIP6.1 to a change in the total toluene feed flowrates: CS3	177
Figure 6.81	Dynamic responses of the HDA process HIP6.2 to a change in the heat load disturbance of cold streams (reactor feed stream): CS1.....	178
Figure 6.82	Dynamic responses of the HDA process HIP6.2 to a change in the heat load disturbance of hot streams (reactor product stream): CS1	179
Figure 6.83	Dynamic responses of the HDA process HIP6.2 to a change in the total toluene feed flowrates: CS1	180

Figure 6.84	Dynamic responses of the HDA process HIP6.2 to a change in the heat load disturbance of cold streams (reactor feed stream): CS2.....	181
Figure 6.85	Dynamic responses of the HDA process HIP6.2 to a change in the heat load disturbance of hot streams (reactor product stream): CS2	182
Figure 6.86	Dynamic responses of the HDA process HIP6.2 to a change in the total toluene feed flowrates: CS2.....	183
Figure 6.87	Dynamic responses of the HDA process HIP6.2 to a change in the heat load disturbance of cold streams (reactor feed stream): CS3.....	184
Figure 6.88	Dynamic responses of the HDA process HIP6.2 to a change in the heat load disturbance of hot streams (reactor product stream): CS3	185
Figure 6.89	Dynamic responses of the HDA process HIP6.2 to a change in the total toluene feed flowrates: CS3.....	186
Figure 6.90	Dynamic responses of the HDA process HIP6.3 to a change in the heat load disturbance of cold streams (reactor feed stream): CS1.....	187
Figure 6.91	Dynamic responses of the HDA process HIP6.3 to a change in the heat load disturbance of hot streams (reactor product stream): CS1	188
Figure 6.92	Dynamic responses of the HDA process HIP6.3 to a change in the total toluene feed flowrates: CS1	189
Figure 6.93	Dynamic responses of the HDA process HIP6.3 to a change in the heat load disturbance of cold streams (reactor feed stream): CS2.....	190
Figure 6.94	Dynamic responses of the HDA process HIP6.3 to a change in the heat load disturbance of hot streams (reactor product stream): CS2	191

Figure 6.95	Dynamic responses of the HDA process HIP6.3 to a change in the total toluene feed flowrates: CS2.....	192
Figure 6.96	Dynamic responses of the HDA process HIP6.3 to a change in the heat load disturbance of cold streams (reactor feed stream): CS3.....	193
Figure 6.97	Dynamic responses of the HDA process HIP6.3 to a change in the heat load disturbance of hot streams (reactor product stream): CS3	194
Figure 6.98	Dynamic responses of the HDA process HIP6.3 to a change in the total toluene feed flowrates: CS3	195

NOMENCLATURES

ALn	The typical HDA process Alternative n; (n = 1, 2, 3 and 4)
HIPn	Heat-Integrated Process of HDA plant n; (n = 1, 2, 3 and 4)
CS1	Design of control structure 1
CS2	Design of control structure 2
CS3	Design of control structure 3
D	Disturbance
MER	Maximum energy recovery
DMER	Dynamic maximum energy recovery
<i>e</i>	error
C _i	Cold stream
H _i	Hot stream
HEN	Heat exchanger network
HIP	Heat integrated process or Heat integrated plant
HPH	Heat pathway heuristics
IAE	Integral absolute error
kF	The kinetic expression for the reaction
P	Pressure, (bar)
r	Reaction rate of reaction
RHEN	Resilient heat exchanger network
T	Temperature, °C
W	The heat capacity flowrate units of kw/hr-°C
B	Bottom product flow rate (kmol/h)
D	Column distillate flow rate (kmol/h)
F	Feed flow rate (kmol/h)
P _b	Column bottom pressure (psia)
P _d	Column top pressure (psia)
Q _c	Heat duty of condenser (kw/h)
Q _r	Heat duty of reboiler (kw/h)
T _b	Column bottoms temperature (°C)
T _d	Column top temperature (°C)

CHAPTER I

INTRODUCTION

This chapter introduces the importance and reasons for research, objectives of the research, scopes of the research, contributions of the research, research methodology and research contents.

1.1 Importance and Reasons for Research

Now, there is growing pressure to reduce capital investment, working capital and operating cost, and to improve safety and environmental concerns. Therefore, chemical engineers have to achieve these tasks by, for example, eliminating many surge tanks, increasing the number of recycle streams or introducing energy integration for both existing and new plants. Nevertheless, recycle streams and energy integrations introduce a feedback of material and energy among units upstream and downstream. They also interconnect separate unit operations and create a path for disturbance propagation. Therefore, a plantwide process control strategy is required to operate an entire plant in order to achieve its objectives.

Essentially, the plantwide control problem is how to develop the control loops needed to operate an entire process and to achieve its design objectives. The problem is extremely complex and is very much opened. There are a combinatorial number of possible choices and alternative strategies to control and manage the disturbance load entering the process. It is recognized that the dynamic simulation is to be used in designing more effective control structures. With the aid of simulation, both research and industrial practitioners can test their ideas and gain insight into process behavior that would not normally be intuitive given the complexity of an entire process design. Unfortunately for the research world, much plantwide information is proprietary and not available in open literature.

However, in recent years several good case studies have been published that allow testing of new control ideas on the level of complexity seen in a typical industrial chemical manufacturing plant. One such study that has been presented by Luyben and Tyreus (1998) provides detailed process and rating information for the manufacture of hydrodealkylation of toluene (HDA) process. In addition, the authors propose and test an entire control structure using their nine-step approach to plantwide process control design. HDA process of toluene to generate benzene consists of a reactor, furnace, vapor-liquid separator, recycle compressor, heat exchangers and distillation columns. This plant is a realistically complex chemical process. It is considering that the energy integration for realistic and large processes is meaningful and useful, it is essential to design a control strategy for process associate with energy integration, so it can be operated well. Hence many controls of heat-integrated systems have been studied by several workers. Terrill and Douglas (1987a, b, c) have proposed six heat exchanger network (HEN) alternatives for the HDA process, in which their energy saving ranges between 29 % and 43 %. Further, study of plantwide process control has also been done by several authors. Luyben et al. (1998) presented a general heuristic design procedure for plantwide process control

This study uses heat exchanger network (HEN) to save energy in the hydrodealkylation (HDA) plant and control structure will be designed using disturbance load propagation method (Wongsri,1990) and Luyben heuristic design method (1983), respectively. So the main objective of this study is to use plantwide control strategies to develop the new control structures for the HDA process with heat-integrated process structures schemes that are designed to achieve the control objective and reduce the cost of production. In this work, the performances of the heat exchanger network (HEN) are designed and their control structures are evaluated via commercial software HYSYS to carry out both steady state and dynamic simulations.

1.2 Objectives of the Research

The objectives of this work are listed below:

1. To design complex heat-integrated HDA process (based on alternative 5 and 6 Douglas, J. M. 1987).
2. To design control structures for complex heat-integrated HDA process.

3. To evaluate performance of control structures of complex heat-integrated HDA process.

1.3 Scopes of the Research

The Scopes of this work are listed below:

1. Description and data of HDA process are obtained from Douglas, J. M. (1988), William L. Luyben, Bjorn D. Tyreus, and Michael L. Luyben (1998), and William L. Luyben (2002).
2. The design complex heat-integrated process structures for HDA process is obtained from Terrill and Douglas 1987 (alternative 5 and 6)
3. The design control structures for complex heat-integrated process HDA process are design using Luyben's heuristics method.
4. Simulation of the HDA process of toluene production using a commercial process simulator -HYSYS.

1.4 Contributions of the Research

The contributions of this work are as follows:

1. The new plantwide control structures for the typical HDA process alternatives 5 and 6.
2. The new complex heat-integrated processes (HIPs) structures for HDA process HIP5 and 6.
3. The new plantwide control structures with complex heat-integrated processes (HIPs) structures for HDA process HIP5 and 6.
4. Process flow diagrams of HDA process with complex heat-integration process HIP5 and 6 have been simulated.

1.5 Research Methodology

The procedures of this research are as follows:

1. Study plantwide process control theory.
2. Study HDA process and related information.

3. Study and Design complex heat-integrated process structures for the typical HDA process alternatives 5 and 6 using HEN heuristics.
4. Steady state simulation of complex heat-integrated process structures for the typical HDA process alternatives 5 and 6.
5. Dynamic simulation of complex heat-integrated process structures for the typical HDA process alternatives 5 and 6.
6. Development of the new design plantwide complex heat-integrated process structures for the typical HDA process alternatives 5 and 6.
7. Steady state and dynamic simulations for the complex heat-integrated process (HIPs) structures HIP5 and 6.
8. Evaluate and analyze of the dynamic performance of the complex heat-integrated process (HIPs) structures.
9. Conclusion of the thesis.

1.6 Research Contents

This thesis is divided into seven chapters.

Chapter I is an introduction of this research. This chapter consists of importance and reasons for research, objectives of the research, scopes of the research, contributions of the research and research methodology.

Chapter II reviews the work that studied the conceptual design of chemical process, heat exchanger network (HEN) and plantwide control design.

Chapter III cover some background information of heat exchanger network design, disturbance transfer technique plantwide (Wongsri, 1990) and theory concerning with plantwide control.

Chapter IV describes the process description and the design of heat exchanger networks for the typical of HDA process.

Chapter V the strategy to design of the complex heat-integrated plant (HIP) of HDA process is proposed.

Chapter VI the new plantwide control structures and dynamic simulation for the complex heat-integrated plant (HIP) structures of HDA process are present.

Chapter VII is the overall conclusions and recommendations of this thesis

CHAPTER II

LITERATURE REVIEW

Our purpose of this chapter is to present a review of the previous work on the conceptual design of chemical process, heat exchanger network (HEN) and plantwide control design.

2.1 A Hierarchical Approach to Conceptual Design

A synthesis/analysis procedure for developing first flowsheets and base case designs has been established by Douglas (1985). The procedure is described in terms of a hierarchy of decision levels, as follows:

1. Batch versus continuous
2. Input-output structure of the flowsheet
3. Recycle structure of the flowsheet
4. Separation system specification, including vapor and liquid recovery system
5. Heat exchanger network (HEN)

Douglas (1985) considered a continuous process for producing benzene by hydrodealkylation of toluene (HDA plant) to illustrate the procedure. The complete process is always considered at each decision level, but additional fine structure is added to the flowsheet as he proceeds to the later decision level. Each decision level terminates in an economic analysis. Experience indicates that less than one percent of the ideals for new designs are ever commercialized, and therefore it is highly desirable to discard poor projects quickly. Similarly, the later level decisions are guided by the economic analysis of the early level decisions.

In a series of papers, Fisher et al. (1988 a, b, c) presented a study of the interface between design and control including process controllability, process operability and selecting a set of controlled variables. At the preliminary stages of a process design, most plants are uncontrollable. That is normally there are not enough

manipulative variables in the flowsheet to be able to satisfy all of the process constraints and to optimize all of the operating variables as disturbances enter the plant. In order to develop a systematic procedure for controllability analysis, Fisher et al. (1988a) used the design decision hierarchy described by Douglas (1985) as the decomposition procedure and considered HDA process as a case study. Where at some levels, that are level 1, 2 and 3, the process is uncontrollable, but controllable at level 4 and level 5. If the available manipulated variables are compared with the constraints and operating variables introduced at each level, the preliminary controllability criterion can often be satisfied. Beside controllability analysis, Fisher et al. (1988b) also focused on operability analysis. The goal of operability analysis is to ensure that there is an adequate amount of equipment over design so that they could satisfy the process constraints and minimize a combination of the operating costs and over design costs over the entire range of anticipated process disturbances. They also followed the same hierarchical procedure to develop operability analysis. For HDA process, the operability decisions were encountered at each level. Fisher et al. (1988c) proposed steady state control structure for HDA process using an optimum steady state control analysis. They found the values of manipulated variables (that minimize the total operating costs for various values of the disturbances) and used it to define the controlled variables.

D. L. Terrill and J. M. Douglas (1988) have studied HDA process from a steady state point of view and determined that the process can be held very close to its optimum for a variety of expected load disturbances by using the following strategy: (1) Fix the flow of recycle gas through the compressor at its maximum value, (2) Hold a constant heat input flowrate in the stabilizer, (3) Eliminate the reflux entirely in the recycle column, (4) Maintain a constant hydrogen-to-aromatic ratio in the reactor inlet by adjusting hydrogen fresh feed, (5) Hold the recycle toluene flowrate constant by adjusting fuel to the furnace, (6) Hold the temperature of the cooling water leaving the partial condenser constant.

Downs and Vogel (1993) described a model of an industrial chemical process for the purpose of developing, studying and evaluating process control technology. It consisted of a reactor/separator/recycle arrangement involving two simultaneous gas-

liquid exothermic reactions. This process was well suited for a wide variety of studies including both plantwide control and multivariable control problems.

Tyreus and W. L. Luyben (1993) considered second order kinetics with two fresh feed makeup streams. Two cases are considered: (1) instantaneous and complete one pass conversion of one of the two components in the reactor so there is an excess of only one component that must be recycled and (2) incomplete conversion per pass so there are two recycle streams. It is shown that the generic liquid-recycle rule proposed by Luyben applies in both of these cases: "snow-balling" is prevented by fixing the flowrate somewhere in the recycle system. An additional generic rule is proposed fresh feed makeup of any component cannot be fixed unless the component undergoes complete single-pass conversion. In the complete on-pass conversion case, throughput can be set by to fix the flowrate of the limiting reactant. The makeup of the other reactant should be set by level control in the reflux drum of the distillation column.

2.2 Heat Exchanger Networks (HENs)

Linhoff, B. and Hindmarsh, E. (1983) presented a novel method for the design of HEN. The method is the first to combine sufficient simplicity to be used by hand with near certainty to identify "best" designs, even for large problems. Best design features the highest degree of energy recovery possible with a given number of capital items. Moreover, they feature network patterns required for good controllability, plant layout, intrinsic safety, etc. Typically, 20-30 percent energy savings, coupled with capital saving, can be realized in state of the art flowsheets by improved HEN design. The task involves the placement of process and utility heat exchangers to heat and cool process streams from specified supply to specified target temperatures.

Linhoff, B., Dunford, H., and Smith, R., (1983) studied heat integration of distillation columns into overall process. This study reveals that good integration between distillation and the overall process can result in column operating at effectively zero utility cost. Generally, the good integration is when the integration as column not crossing heat recovery pinches of the process and either the reboiler or the

condenser being integrated with the process. If these criteria can be met, energy cost for distillation can effectively be zero.

Saboo and Morari (1983) classified flexible HENs into two classes according to the kind and magnitude of disturbances that effect the pinch location. For the temperature variation, they show that if the MER can be expressed explicitly as a function of stream supply and target conditions the problem belongs to Class I, i.e. the case that small variations in inlet temperatures do not affect the pinch temperature location. If an explicit function for the minimum utility requirement valid over the whole disturbance range does not exist, the problem is of Class II, i.e. the case that large changes in inlet temperature or flowrate variations cause the discrete changes in pinch temperature locations.

Marselle et al. (1982) addressed the problem of synthesizing heat recovery networks, where the inlet temperatures vary within given ranges and presented the design procedure for a flexible HEN by finding the optimal network structures for four selected extreme operating conditions separately. The specified worst cases of operating conditions are the maximum heating, the maximum cooling, the maximum total exchange and the minimum total exchange. The network configurations of each worst condition are generated and combined by a designer to obtain the final design. The strategy is to derive similar design in order to have as many common units as possible in order to minimize number of units.

Linnhoff and Kotjabasakis (1984) developed a design procedure for operable HENs by inspection and using the concept of downstream paths, i.e. the paths that connect the disturbed variables downstream to the controlled variables. They generated HEN design alternatives by the pinch method for the nominal operating condition. Then, the alternative designs are inspected for the effects of disturbances on the controlled variables and they are removed by breaking the troublesome downstream paths. Path breaking can be done by relocating and/or removing exchangers. If this procedure is not feasible, control action is inserted into the structure.

Saboo and Morari (1984) proposed the corner point theorem which states that for temperature variation only, if a network allows MER without violating ΔT_{\min} at M

corner points, then the network is structurally resilient or flexible. This is the case where the constraint is convex, so examining the vertices of the polyhedron is sufficient. This procedure again can only apply to restricted classes of HEN problem. Their design procedure is similar to Marselle et al. (1982), but using two extreme cases to develop the network structure. The strategy for both procedures is finding similar optional network structures for the extreme cases and the base case design in order that they may be easily merged and not have too many units. Two extreme cases are:

1. When all streams enter at their maximum inlet temperatures and the heat capacity flowrates of hot streams are maximal and those of cold streams minimal. This is the case of maximum cooling.
2. When all streams enter at their minimum inlet temperatures and the heat capacity flowrates of hot streams are minimal and those of cold streams maximal. This is an opposite case the above one and in this case maximum heating is required.

The 'base' design is then generated by using an optimization technique and the final design is obtained by combining these designs. A test for resiliency (calculating, RI) is required. If the design is not feasible a modification is done by attempting to reduce ΔT_{\min} and if not successful, a new heat exchanger will added or some heat exchangers are located. If the modified network is still not resilient, synthesize network structures at all corner points where the current design is not feasible. The new structures should be as similar to the current design as possible. The new design is obtained by superimposing the current structure and the new structures. The unneeded heat exchangers are inspected and removed.

Floudas and Grossmann (1987) presented a synthesis procedure for resilient HENs. Their multiperiod operation transshipment model is used to find a match structure for selected design points. The design obtained for feasibility at the match level. If it is not feasible, the critical point is added as an additional operating point and the problem is reformulated and solved. If the match network is feasible then the multiperiod superstructure is derived and formulated as an NLP problem to find a minimum unit solution.

Calandranis and Stephanopoulos (1988) proposed a new approach to address the following problems: design the configuration of control loops in a network of heat exchangers and sequence the control action of the loops, to accommodate set point changes and reject load disturbances. The approach proposed exploits the structure characteristics of a HEN by identifying routes through the HEN structure that can allocate load (disturbances, or set point changes) to available sinks (external coolers or heaters). They also discussed several design issues such as the placement of bypass lines and the restrictions imposed by the existence of a process pinch. An online, real-time planning of control actions is the essence of implementation strategies generated by an expert controller, which selects path through the HEN is to be used for each entering disturbance or set point change, and what loops should be activated (and in what sequence) to carry the associated load (disturbance or set point change) to a utility unit.

Colberg (1989) suggested that flexibility should deal with planned, desirable changes that often have a discrete set of values. Whereas resilience deals with unplanned, undesirable changes which are naturally continuous values. Thus a flexibility problem is a 'multiple period' type of problem. A resilience problem should be a problem with a continuous range of operating conditions in the neighborhood of nominal operating points.

Wongsri, M., (1990) studied a resilient HENs design. He presented a simple but effective systematic synthesis procedure for the design of resilient HEN. His heuristic design procedure is used to design or synthesize HENs with pre-specified resiliency. It used physical and heuristic knowledge in finding resilient HEN structures. The design must not only feature minimum cost, but must also be able cope with fluctuation or changes in operating conditions. The ability of a HEN to tolerate unwanted changes is called resiliency. It should be noted that the ability of a HEN to tolerate wanted changes is called flexibility. A resilient HEN synthesis procedure was developed based on the match pattern design and a physical understanding of the disturbances propagation concept. The disturbance load propagation technique was developed from the shift approach and was used in a systematic synthesis method. The design condition was selected to be the minimum heat load condition for easy accounting and interpretation. This is a condition where

all process streams are at their minimum heat loads, e.g. the input temperatures of hot streams are at the lowest and those of cold streams are at the highest.

Ploypaisangsang A., (2003) presented to redesign six alternatives for HDA process to be the resiliency networks for maintain the target temperature and also achieve maximum energy recovery (MER). The best resilient network is selected by to trade-off between cost and resiliency. The auxiliary unit should be added in the network for cope safely with the variations and easy to design control structure to the network.

2.3 Design and Control of Energy-Integrated Plants

Renanto Handogo and W. L. Luyben (1987) studied the dynamics and control of heat-integrated reactor/column system. An exothermic reactor was the heat source, and a distillation column reboiler was the heat sink. Two types of heat-integration systems were examined: indirect and direct heat integration. Both indirect and direct heat integration systems are found in industry. In the indirect heat-integration system, steam generation was used as the heating medium for the reboiler. The direct heat integration system used the reactor fluid to directly heat the column. The indirect heat-integration system was found to have several advantages over the direct heat integration system in term of its dynamic performance. Both systems were operable for both large and small temperature differences between the reactor and column base.

M.L. Luyben, and W.L. Luyben (1995) examines the plantwide design and control of a complex process. The plant contains two reaction steps, three distillation columns, two recycle streams, and six chemical components. Two methods, a heuristic design procedure and a nonlinear optimization, have been used to determine an approximate economically optimal steady-state design. The designs differ substantially in terms of the purities and flow rates of the recycle streams. The total annual cost of the nonlinear optimization design is about 20 % less than the cost of the heuristic design. An analysis has also been done to examine the sensitivity to design parameters and specifications. Two effective control strategies have been developed using guidelines from previous plantwide control studies; both require reactor composition control as well as flow control of a stream somewhere in each recycle

loop. Several alternative control strategies that might initially have seemed obvious do not work.

M.L. Luyben, B.D. Tyreus, and W.L. Luyben (1997) presented A general heuristic design procedure is presented that generates an effective plantwide control structure for an entire complex process flowsheet and not simply individual units. The nine steps of the proposed procedure center around the fundamental principles of plantwide control: energy management; production rate; product quality; operational, environmental and safety constraints; liquid-level and gas-pressure inventories; makeup of reactants; component balances; and economic or process optimization. Application of the procedure is illustrated with three industrial examples: the vinyl acetate monomer process, the Eastman plantwide-control process, and the HDA process. The procedure produced a workable plantwide control strategy for a given process design. The control system was tested on a dynamic model built with TMODS, Dupont's in-house simulator.

From the W.L. Luyben (2000) studied the process had the exothermic, irreversible, gas-phase reaction $A + B \rightarrow C$ occurring in an adiabatic tubular reactor. A gas recycle returns unconverted reactants from the separation section. Four alternative plantwide control structures for achieving reactor exit temperature control were explored. The reactor exit temperature controller changed different manipulated variables in three of the four control schemes: (1) CS1, the set point of the reactor inlet temperature controller was changed; (2) CS2, the recycle flow rate was changed; and (3) CS3, the flow rate of one of the reactant fresh feeds was changed. The fourth control scheme, CS4, uses an "on-demand" structure. Looking at the dynamics of the reactor in isolation would lead one to select CS2 because CS1 had a very large deadtime (due to the dynamics of the reactor) and CS3 had a very small gain. Dynamic simulations demonstrated that in the plantwide environment, with the reactor and separation operating together, the CS3 structure gave effective control and offered an attractive alternative in those cases where manipulation of recycle flow rate was undesirable because of compressor limitations. The on-demand CS4 structure was the best for handling feed composition disturbances.

Wongsri and Kietawarin (2002) presented a comparison among 4 control structures designed for withstanding disturbances that cause production rate change of HDA process. The changes had been introduced to the amount of toluene and feed temperature before entering the reactor. Compared with the reference control structure using a level control to control toluene quantity in the system, the first control scheme measured toluene flow rate in the process and adjusted the fresh toluene feed rate. This structure resulted in faster dynamic response than the reference structure. The second control scheme was modified from the first scheme by adding a cooling unit to control the outlet temperature from the reactor, instead of using internal process flow. The result was to reduce material and separation ratio fluctuations within the process. The product purity was also quite steadily. In the third control scheme, a ratio control was introduced to the second control scheme for controlling the ratio of hydrogen and toluene within the process. This scheme showed that it could withstand large disturbances. Dynamic study showed that the control structure had significant effect on process behavior. A good system control should quickly respond to disturbances and adjust itself to steady state while minimizing the deviation of the product quality. The control structures were compared with reference on plantwide process control book, Luyben 1998, the result was performance of these structures higher than reference.

Wongsri and Thaicharoen (2004) presented the new control structures for the hydrodealkylation of toluene (HDA) process with energy integration schemes alternative 3. Five control structures have been designed, tested and compared the performance with Luyben's structure (CS1). The result shows that hydrodealkylation of toluene process with heat integration can reduce energy cost. Furthermore, this process can be operated well by using plantwide methodology to design the control structure. The dynamic responses of the designed control structures and the reference structure are similar. The CS2 has been limited in bypass, so it is able to handle in small disturbance. CS3 has been designed to improve CS2 in order to handle more disturbances by using auxiliary heater instead of bypass valve to control temperature of stabilizer column. The recycle column temperature control response of the CS4 is faster than that of the previous control structures, because reboiler duty of column can control the column temperature more effective than bottom flow. CS5 on-demand structure has an advantage when downstream customer desires immediate responses

in the availability of the product stream from this process. The energy used in CS6 control structure is less than CS1 and CS4.

Wongsri and Hermawan Y.D. (2004) studied the control strategies for energy-integrated HDA plant (i.e. alternatives 1 and 6) based on the heat pathway heuristics (HPH), i.e. selecting an appropriate heat pathway to carry associated load to a utility unit, so that the dynamic MER can be achieved with some trade-off. In their work, a selective controller with low selector switch (LSS) is employed to select an appropriate heat pathway through the network. The new control structure with the LSS has been applied in the HDA plant alternatives 1 and 6. The designed control structure is evaluated based on the rigorous dynamic simulation using the commercial software HYSYS. The study reveals that, by selecting an appropriate heat pathway through the network, the utility consumptions can be reduced according to the input heat load disturbances; hence the dynamic MER can be achieved.

Kunajitpimol (2006) presented the resilient heat exchanger networks to achieve dynamic maximum energy recovery, plantwide control structures, and control strategies are designed for Butane Isomerization plant. The control difficulties associated with heat integration are solved by adding auxiliary utilities which is kept minimal. Four alternatives of heat exchanger networks (HEN) designs of the Butane Isomerization plant are proposed. They used the heat from the reactor effluent stream to provide the heat for the column reboiler. The energy saved is 24.88% from the design without heat integration, but the additional capital is 0.67 % due to adding of a process to process exchanger and an auxiliary utility exchanger to the process. The plantwide control configuration of heat-integrated plant is designed following Luyben's heuristic method. Various heat pathways throughout the network designed using Wongsri's disturbance propagation method to achieve DMER.

CHAPTER III

PLANTWIDE CONTROL FUNDAMENTALS

Many chemical plants are integrated process as material recycle and energy integration which increase interaction between unit operations. Therefore the control system that not just combines the control schemes of each individual unit cannot achieve our control objective. The strategy of plantwide process control which designs a control system from the viewpoint of the entire plant can be solved. Hence, our purpose of this chapter is to present plantwide control fundamentals.

3.1 Incentives for Chemical Process Control

A chemical plant is an arrangement of processing units (reactors, heat exchangers, pumps, distillation columns, absorbers, evaporators, tanks, etc.), integrated with one another in a systematic and rational manner. The plant's overall objective is to convert certain raw materials into desired products using available sources of energy in the most economical way.

There are three general classes of needs that a control system is called on to satisfy: suppressing the influence of external disturbances, ensuring the stability of a chemical process, and optimizing the performance of a chemical process (Stephanopoulos, 1984).

3.1.1 Suppressing the Influence of External Disturbances

Suppressing the influence of external disturbances on a process is the most common objective of a controller in a chemical plant. Such disturbances, which denote the effect that the surroundings have on a reactor, separator, heat exchanger, compressor and so on, are usually out of the reach of human operator. Consequently, we need to introduce a control mechanism that will make the proper change on the process to cancel the negative impact that such disturbances may have on the desired

operation of a chemical plant. In other words, the strategies for control are very important to face all disturbances entering the process.

3.1.2 Ensuring the Stability of a Chemical Process

The process is stable or self-regulating, if the process variable such as temperature, pressure, concentration, or flow rate stays at a certain point or at a desired steady state value as time progresses. Otherwise, the process is unstable and requires external control for the stabilization of their behavior.

3.1.3 Optimizing the Performance of a Chemical Process

Safety and the satisfaction of product specifications are the two principal operational objectives for a chemical plant. Once these are achieved, the next goal is how to make the operation of the plant more profitable. It is clear that we would like to be able to change the operation of the plant (flow rates, pressures, concentrations, temperatures) in such a way that an economic objective (profit) is always maximized.

3.2 Integrated Processes

Three basic features of integrated chemical processes lie at the root of the need to consider the entire plant's control system: (1) the effect of material recycle, (2) the effect of energy integration, and (3) the need to account for chemical component inventories. However, there are fundamental reasons why each of these exists in virtually all-real processes.

3.2.1 Material Recycle

Material is recycled for six basic and important reasons

- a. *Increase conversion*: For chemical processes involving reversible reactions, conversion of reactants to products is limited by thermodynamic equilibrium constraints. Therefore, the reactor effluent by necessity contains both reactants and products. Separation and recycle of reactants are essential if the process is to be economically viable.

- b. *Improve economics*: In most systems it is simply cheaper to build a reactor with incomplete conversion and recycle reactants than it is to reach the necessary conversion level in one reactor or several in series.
- c. *Improve yields*: In reaction system such as $A \rightarrow B \rightarrow C$, where B is desired product, the per-pass conversion of A must be kept low to avoid producing too much of undesirable product C. Therefore the concentration of B is kept fairly low in the reactor and a large recycle of A is required.
- d. *Provide thermal sink*: In adiabatic reactors and in reactors where cooling is difficult and exothermic heat effects are large, it is often necessary to feed excess material to the reactor so that reactor temperature increase will not be too large. High temperature can potentially create several unpleasant events, such as thermal runaway, deactivation of catalysts, cause undesirable side reaction, etc. So the heat of reaction is absorbed by the sensible heat required to raise the temperature of the excess material in the stream flowing through the reactor.
- e. *Prevent side reactions*: A large excess of one of the reactants is often used that the concentration of the other reactant is kept low. If this limiting reactant is not kept in low concentration, it could react to produce undesirable products. Therefore, the reactant that is in excess must be separated from the products components in the reactor effluent stream and recycled back to the reactor.
- f. *Control properties*: In many polymerization reactors, conversion of monomer is limited to achieve the desired polymer properties. These include average molecular weight distribution, degree of branching, particle size, etc. Another reason for limiting conversion to polymer is to control the increase in viscosity that is typical of polymer solutions. This facilitates reactor agitation and heat removal and allows the material to be further processed.

3.2.2 Energy Integration

The fundamental reason for the use of energy integration is to improve the Thermodynamic efficiency of the process. This translates into a reduction in utility cost. For energy-intensive processes, the savings can be quite significant.

3.2.3 Chemical Component Inventories

A plant's chemical species can be characterized into three types: reactants, products, and inerts. A material balance for each of these components must be satisfied. This is typically not a problem for products and inerts. However, the real problem usually arises when reactants (because of recycle) are considered and accounted for their inventories within the entire process. Because of their value, it is necessary to minimize the loss of reactants exiting the process since this represents a yield penalty. So we prevent reactants from leaving. This means we must ensure that every mole of reactant fed to the process is consumed by reactions.

3.3 Basic Concepts of Plantwide Control

3.3.1 Buckley Basics:

Page Buckley (1964) was the first to suggest the idea of separating the plantwide control problem into two parts: material balance control and product quality control. He suggested looking first at the flow of material through the system. A logical arrangement of level and pressure control loops is established, using the flowrates of the liquid and gas process streams. Note that most level controllers should be proportional-only (P) to achieve flow smoothing.

He then proposed establishing the product-quality control loops by choosing appropriate manipulated variables. The time constants of closed-loop product quality loops are estimated. We try to make these as small as possible so that good, tight control is achieved, but stability constraints impose limitations on the achievable performance.

3.3.2 Douglas Doctrines:

Because of the cost of raw materials and the values of products are usually much greater than the costs of capital and energy, Jim Douglas (1988) leads to the two *Douglas doctrines*:

- a. Minimize losses of reactants and products
- b. Maximize flowrates through gas recycle systems.

The first idea implies that we need tight control of stream compositions exiting the process to avoid losses of reactants and products. The second rests on the principle that yield is worth more than energy. Recycles are used to improve yields in many processes. The economics of improving yields (obtaining more desired products from the same raw materials) usually outweigh the additional energy cost of driving the recycle gas compressor.

3.3.3 Downs Drill:

Chemical component balances around the entire plant are important things, and checking to see that the control structure handles these component balances effectively. The concepts of overall component balances go back to basic principle in chemical engineering, which is how to apply mass and energy balances to any system, microscopic or macroscopic. We check these balances for individual unit operations, for sections of a plant, and for entire processes.

We must ensure that all components (reactants, products, and inert) have a way to leave or be consumed within the process. The consideration of inert is seldom overlooked. Heavy inert can leave the system in bottoms product from distillation column. Light inert can be purged from a gas recycle stream or from a partial condenser on a column. Intermediate inert must also be removed in some way, such as in side stream purges or separate distillation columns.

Most of the problems occur in the consideration of reactants, particularly when several chemical species are involved. All of reactants fed into the system must either be consumed via reaction or leave the plant as impurities in exiting streams. Since we usually want to minimize raw material costs and maintain high-purity products, most of the reactant fed into the process must be chewed up in the reactions.

3.3.4 Luyben Laws:

Three laws have been developed as a result of a number of case studies of many systems:

- a. A stream somewhere in all recycle loops should be flow controlled. This is to prevent the snowball effect.

- b. A fresh reactant feed stream cannot be flow controlled unless there is essentially complete one pass conversion of one of reactants. This law applies to systems with reaction types such as $A + B \rightarrow \text{products}$. In system with consecutive reactions such as $A + B \rightarrow M + C$ and $M + B \rightarrow D + C$, the fresh feed can be flow controlled into the system, because any imbalance in the ratios of reactants is accommodated by a shift in the amounts of the two products (M and D) that are generated. An excess of A will result in the production of more M and less D. And vice versa, an excess of B results in the production of more D and less M.
- c. If the final product from process comes out the top distillation column, the column feed should be liquid. If the final product comes out from the bottom of the column, the feed to the column should be vapor. Changes in feed flowrate or feed composition have less of a dynamic effect on distillate composition than they do on bottoms composition if the feed is saturated liquid. The reverse is true if the feed is saturated vapor: bottom is less affected than distillate.

3.3.5 Richardson Rule:

Bob Richardson suggested the heuristic that the largest stream should be selected to control the liquid level in a vessel. This makes good sense because it provides more *muscle* to achieve the desired control objective. The largest stream has the biggest effect to volume of vessel. An analogy is that it is much easier to maneuver a large barge with a tugboat than a life raft. The point is that the bigger the handle you have to affect a process, the better you can control it.

3.3.6 Shinskey Schemes:

Greg Shinskey (1988) has produced a number of “advanced control” structures that permit improvements in dynamic performance. These schemes are not only effective, but they are simple to implement in basic control instrumentation.

3.3.7 Tyreus Tuning:

One of the vital steps in developing a plantwide control system is how to determine the algorithm to be used for each controller (P, PI or PID) and to tune each controller. The use of P-only controllers is recommended for liquid levels. Tuning of P controller is usually trivial, that is set the controller gain equal to 1.67. This will have the valve wide open when the level at 80 percent and the valve shut when the level is at 20 percent.

For other control loops, the use of PI controllers is suggested. The relay-feedback test is simple and fast way to obtain the ultimate gain (K_u) and ultimate period (P_u). The Ziegler-Nichols settings (for very tight control with a closed-loop damping coefficient of about 0.1) or the Tyreus-Luyben settings (for more conservation loops where a closed-loop damping coefficient of 0.4 is more appropriate) can be used for tuning the parameters of controller:

$$\begin{aligned} K_{ZN} &= K_u/2.2 & \tau_{ZN} &= P_u/1.2 \\ K_{TL} &= K_u/3.2 & \tau_{TL} &= 2.2 P_u \end{aligned}$$

The use of PID controllers should be restricted to those loops where two criteria are both satisfied: the controlled variable should have a very large signal-to-noise ratio and tight dynamic control is really essential.

3.4 Plantwide Control Design Procedure

The plantwide control procedure has been established based upon heuristics (Luyben et al., 1997). The nine steps of the design procedure center around the fundamental principles of plantwide control: energy management; production rate; product quality; operational, environmental, and safety constraints; liquid level and gas pressure inventories; make up of reactants; component balances; and economic or process optimization. This heuristic design procedure is described below.

3.4.1 Establish Control Objectives

Assess the steady-state design and dynamic control objectives for the process.
This is probably the most important aspect of the problem because different criteria

lead to different control structures. These objectives include reactor and separation yields, product quality specifications, product grades and demand determination, environmental restrictions, and the range of operating conditions.

3.4.2 Determine Control Degrees of Freedom

Count the number of control valves available. This is the number of degrees of freedom for control, that is, the number of variables that can be controlled to setpoint. The valves must be legitimate (flow through a liquid-filled line can be regulated by only one control valve). The placement of these control valves can sometimes be made to improve dynamic performance, but often there is no choice in their location.

Most of these valves will be used to achieve basic regulatory control of the process: (1) set production rate, (2) maintain gas and liquid inventories, (3) Control product qualities, and (4) avoid safety and environmental constraints. Any valves that remain after these vital tasks have been accomplished can be utilized to enhance steady-state economic objectives or dynamic controllability (e.g., minimize energy consumption, maximize yield, or reject disturbances).

3.4.3 Establish Energy Management System

Make sure that energy disturbances do not propagate throughout the process by transferring the variability to the plant utility system. The term energy management is used to describe two functions. First, we must provide a control system that remove exothermic heats of reaction from the process. If heat is not removed to utilities directly at the reactor, then it can be used elsewhere in the process by other unit operations. This heat, however, must ultimately be dissipated to utilities. If heat integration does occur between process streams, then the second function of energy management is to provide a control system that prevents propagation of the thermal disturbances and ensures that the exothermic reactor heat is dissipated and not recycled. Process-to-process heat exchangers and heat-integrated unit operations must be analyzed to determine that there are sufficient degrees of freedom for control.

Heat removal in exothermic reactors is crucial because of the potential for thermal runaways. In endothermic reactions, failure to add enough heat simply results in the reaction slowing up. If the exothermic reactor is running adiabatically, the control system must prevent excessive temperature rise through the reactor (e.g., by setting the ratio of the flow rate of the limiting fresh reactant to the flow rate of a recycle stream acting as a thermal sink).

Increased use of heat integration can lead to complex dynamic behavior and poor performance due to recycling of disturbances. If not already in the design, trim heaters/coolers or heat exchanger bypass lines must be added to prevent this. Energy disturbances should be transferred to the plant utility system whenever possible to remove this source of variability from the process units.

3.4.4 Set Production Rate

Establish the variables that dominate the productivity of the reactor and determine the most appropriate manipulator to control production rate. Often design constraints require that production be set at a certain point. An upstream process may establish the feed flow sent to the plant. A downstream process may require on-demand production, which fixes the product flow rate from the plant.

If no constraint applies, then we select the valve that provides smooth and stable production-rate transitions and rejects disturbances. We often want to select the variable that has the least effect on the separation section, but also has a rapid and direct effect on reaction rate in the reactor without heating an operational constraint. This may be the feed flow to the separation section, the flow rate of recycle stream, the flow rate of initiator or catalyst to the reactor, the reactor heat removal rate, the reactor temperature, and so forth.

3.4.5 Control Product Quality, Handle Safely, Operational, and Environmental Constraints

Select the best valves to control each of the product-quality, safety, and environmental variables. We want tight control of these quantities for economic and operational reasons. Hence we should select manipulated variables such that the

dynamic relationships between controlled and manipulated variables feature small time constants and dead times and large steady-state gains. The former gives small closed-loop time constants, and the latter prevents problems with the range-ability of the manipulated variable (control-valve saturation).

3.4.6 Control Inventories (Pressure and Liquid Level) and Fix a Flow in Every Recycle Loop

Fix a flow in every recycle loop and then select the best manipulated variables to control inventories. Determine the valve to control each inventory variable. These variables include all liquid levels (except for surge volume in certain liquid recycle streams) and gas pressures. An inventory variable should typically be controlled with the manipulated variable that has the largest effect on it within that unit.

Proportional-only control should be used in non-reactive control loops for cascade unit in series. Even in reactor-level control, proportional control should be considered to help filter flow-rate disturbances to the downstream separation system. There is nothing necessarily sacred about holding reactor level constant.

In most processes a flow controller should be present in all liquid recycle loops. This is a simple and effective way to prevent potentially large changes in recycle flows that can occur if all flows in recycle loops are controlled by levels. Two benefits result from this flow-control strategy. First, the plant's separation section is not subjected to large load disturbances. Second, consideration must be given to alternative fresh reactant makeup control strategies rather than flow control. In dynamic sense, level controlling all flows in recycle loop is a case of recycling of disturbances and should be avoided.

3.4.7 Check Component Balances

Identify how chemical components enter, leave, and are generated or consumed in the process. Ensure that the overall component balance for each species can be satisfied either through reaction or exit streams by accounting for the component's composition or inventory at some point in the process.

Light, intermediate, and heavy inert components must have an exit path from the system. Reactant must be consumed in the reaction section or leaves as impurities in the product streams. Fresh reactant makeup feed stream can be manipulated to control reactor feed composition or a recycle stream composition (or to hold pressure or level as noted in previous step). Purge stream can also be used to control the amount of high- or low-boiling impurities in a recycle stream.

3.4.8 Control Individual Unit Operations

Establish the control loops necessary to operate each of the individual unit operations. For examples, a tubular reactor usually requires control of inlet temperature. High-temperature endothermic reactions typically have a control system to adjust fuel flow rate to a furnace supplying energy to the reactor. Crystallizers require manipulation of refrigeration load to control temperature. Oxygen concentration in stack gas from a furnace is controlled to prevent excess fuel usage. Liquid solvent feed flow to an absorber is controlled as some ratio to the gas feed.

3.4.9 Optimize Economic and Improve Dynamic Controllability

Establish the best way to use the remaining control degrees of freedom. After satisfying all of the basic regulatory requirements, we usually have additional degrees of freedom involving control valves that have not been used and setpoints in some controllers that can be adjusted. These can be utilized used either to optimize steady-state economic process performance (e.g., minimize energy, maximize selectivity) or to improve dynamic response.

For example, an exothermic chemical reactor can be cooled with both jacket cooling water and brine (refrigeration) to a reflux condenser. A valve-position control strategy would allow fast, effective reactor temperature control while minimizing brine use.

3.5 Plantwide Energy Management

Energy conservation has always been important in process design. Thus, it is

common practice to install feed-effluent heat exchangers (FEHEs) around reactors and distillation columns. In any process flowsheet, a number of streams must be heated, and other streams must be cooled. For example, in HDA process, the toluene fresh feed, the makeup hydrogen, the recycle toluene, and the recycle gas stream must be heated up to the reaction temperature 621.1°C . And, the reactor effluent stream must also be cooled to the cooling water temperature to accomplish a phase split. Therefore, the energy integration is required to reduce the utility cost and also to improve thermodynamic efficiency of the process.

3.5.1 Heat Exchanger Dynamics

Heat exchangers have fast dynamics compared to other unit operations in a process. Normally the time constant is measured in second but could be up to a few minutes for large exchangers. Process-to-process exchangers should be modeled rigorously by partial differential equations since they are distributed systems. This introduces the correct amount of dead time and time constant in the exit stream temperatures, but the models are inconvenient to solve.

For the purpose of plantwide control studies it is not necessary to have such detailed descriptions of the exchanger dynamics, since these units rarely dominate the process response. Instead, it is often possible to construct useful models by letting two sets of well-stirred tanks in series exchange heat. This simplifies the solution procedure.

3.5.2 Heat Pathways

A path is a connection between a heater and a cooler in a network. In plantwide energy management, various pathways for heat need to be identified. Furthermore, a control strategy that allows effective delivery and removal of energy is needed to minimize propagation of thermal disturbances. It is important to realize that there are no thermodynamic restrictions on the energy requirement to transition streams between unit operations. In other words, the heating and cooling of streams are done for practical reasons and not to satisfy the laws of thermodynamics. This energy would not be an issue if all the processing steps operated at the same constant temperature. Furthermore, since raw materials and products are stored at roughly the

same temperature, the net energy requirement for heating and cooling equal the heat losses from the process.

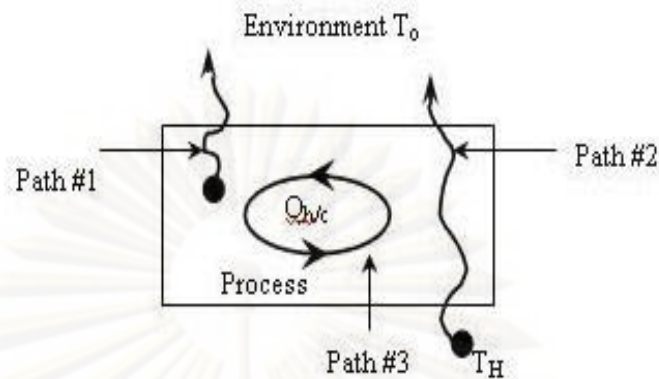

Figure 3.1 Heat pathways

From plantwide perspective we can now discern three different “heat pathways” in the process as illustrated in Figure 3.1. The first pathway, heat from the process is dissipated to the environment, e.g. heat generated by exothermic reactions and by degradation of mechanical work (e.g., compression, pressure drop and friction). This pathway is from inside the process and flows out. It is of course possible to convert some of the heat to work as it is removed from high temperature in the process.

A second pathway carries heat from utilities into the process. Mechanical work is extracted from the heat as it flows from a high supply temperature to the lower temperature of the environment. This pathway goes through the process and is needed to satisfy the thermodynamic work requirements of separation. Work is also extracted from the heat stream to overcome process inefficiencies associated with stream mixing and heat transfer.

The third pathway is internal to the process. Here heat flows back and forth between different unit operations. The magnitude of this energy path depends upon the heating and cooling needs and the amount of heat integration implemented. Whenever the internal path is missing, and there is a heating requirement, the heat has to be supplied from utilities. The same amount of heat must eventually be rejected to the environment elsewhere in the process.

3.5.3 Heat Recovery

Usually, chemical processes are thermally inefficient. First, the chemical work available in the reactants is dissipated as heat. Second, the work required for separation is usually supplied as heat to distillation column, which has internal inefficiencies. Finally, energy is needed for heating and cooling functions that are independent of thermodynamic constraints. This all adds up to a low thermal efficiency.

Fortunately, we can make great improvements in plant's thermal efficiency by recycling much of the energy needed for heating and cooling process streams. It is also possible to introduce heat integration schemes for distillation columns to reduce the separation heat. And finally the reaction heat can be recovered in waste heat boilers and use the steam for power generation. There is of course a capital expense associated with improved efficiency but it can usually be justified when the energy savings are accounted for during the lifetime of the project. Of more interest to us in the current context is how heat integration affects the dynamics and control of a plant and how we can manage energy in plants with a high degree of heat recovery.

3.6 Control of Process-to-Process Exchangers

Process-to-process (P/P) exchangers are used for heat recovery within a process. Most heat exchanger network are not operable at the optimum steady state design conditions; i.e., normally they can tolerate disturbances that decrease the loads but not those that increase loads and there are not an adequate number of manipulative variables to be able to satisfy the process constraints and to optimize all of the significant operating variables. These types of operability limitations can be identified by using steady state considerations, and normally these operability limitations can be overcome by installing an appropriate utility exchanger and by installing bypass around the exchangers.

3.6.1 Bypass Control

When the bypass method is used for unit operation control, we have several

choices about the bypass location and the control point. Figure 3.2 shows the most common alternatives. For choosing the best option, it depends on how we define the best. Design consideration might suggest, we measure and bypass on the cold side since it is typically less expensive to install a measurement device and a control valve for cold service than it is for high-temperature service. Cost consideration would also suggest a small bypass flow to minimize the exchanger and control valve sizes.

From a control standpoint we should measure the most important stream, regardless of temperature, and bypass on the same side as well we control (see Fig 3.2.a and c). This minimizes the effects of exchanger dynamics in the loop. We should also want to bypass a large fraction of the controlled stream since it improves the control range. This requires a large heat exchanger. There are several general heuristic guidelines for heat exchanger bypass streams. We typically want to bypass the flow of the stream whose temperature we want to control. The bypass should be about 5 to 10 percent of the flow to be able to handle disturbances.

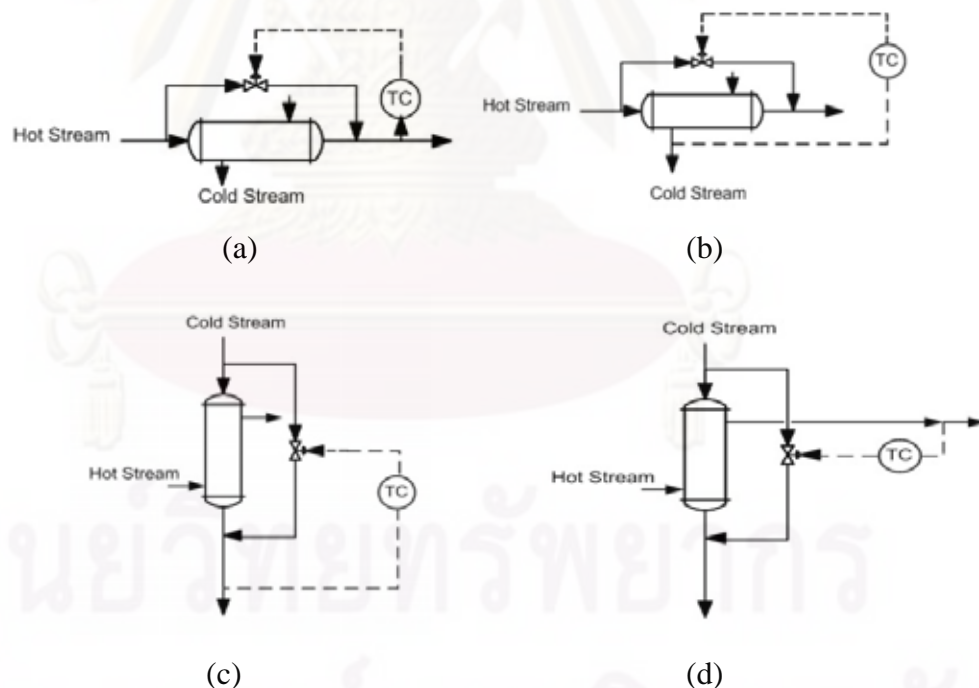

Figure 3.2: Bypass control of process-to-process heat exchangers. (a) Controlling and bypassing hot stream; (b) controlling cold stream and bypassing hot stream; (c) controlling and bypassing cold stream; (d) controlling hot stream and bypassing cold stream.

Finally, we must carefully consider the fluid mechanics of the bypass design for the pressure drops through the control valves and heat exchanger.

3.6.2 Use of Auxiliary Utility Exchangers

When the P/P exchanger is combined with a utility exchanger, we also have a few design decisions to make. The utility exchanger can be installed to P/P exchanger either in series or parallel. Figure 3.3 shows the combination of P/P exchanger with a utility exchanger. Generally, the utility system of a complex energy-integrated plant is designed to absorb large disturbances in the process, and making process-to-utility exchangers relatively easy to control.

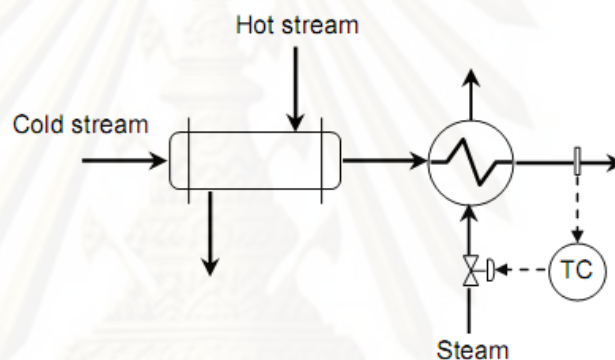

Figure 3.3 Control of process-to-process heat exchanger using the auxiliary utility.

The relative sizes between the recovery and the utility exchangers must be established. From a design standpoint we would like to make the recovery exchanger large and utility exchanger small. This gives the most heat recovery, and it is also the least expensive alternative from an investment standpoint.

CHAPTER IV

TYPICAL HDA PROCESS

4.1 Process Description

The hydrodealkylation (HAD) of toluene process by Douglas (1988) on conceptual design as shown in Figure 4.1 contains nine basic unit operations: reactor, furnace, vapor-liquid separator, recycle compressor, two heat exchangers, and three distillation columns. Two vapor-phase reactions are considered to generate benzene, methane, and diphenyl from reactants toluene and hydrogen. The two vapor-phase reactions are:



The kinetic rate expressions are functions of the partial pressure (in psia) of toluene p_T , hydrogen p_H , benzene p_B , and diphenyl p_D , with an Arrhenius temperature dependence. Zimmerman and York (1964) provide the following rate expression:

$$r_1 = 3.6858 * 10^6 \exp(-25,616/T) p_T p_H^{1/2} \quad (4.3)$$

$$r_2 = 5.987 * 10^4 \exp(-25,616/T) p_B^2 - 2.553 * 10^5 \exp(-25,616/T) p_D p_H \quad (4.4)$$

Where r_1 and r_2 have units of $\text{lb} \cdot \text{mol} / (\text{min} \cdot \text{ft}^3)$ and T is the absolute temperature in Kelvin. The heats of reaction given by Douglas (1988) are $-21,500$ Btu/lb \cdot mol of toluene for r_1 and 0 Btu/lb \cdot mol for r_2 .

The effluent from the adiabatic reactor is quenched with liquid from the separator. This quenched stream is the hot-side feed to the process-to-process heat exchanger, where the cold stream is the reactor feed stream prior to the furnace. The reactor effluent is then cooled with cooling water and the vapor (hydrogen, methane) and liquid (benzene, toluene, and diphenyl) are separated. The vapor stream from the

separator is split and the remainder is sent to the compressor for recycle back to the reactor.

The liquid stream from the separator (after part is taken for the quench) is fed to the stabilizer column, which has a partial condenser component. The bottoms stream from the stabilizer is fed to the product column, where the distillate is the benzene product from the process and the bottoms is toluene and diphenyl fed to the recycle column. The distillate from the recycle column is toluene that is recycled back to the reactor and the bottom is the diphenyl byproduct.

Makeup toluene liquid and hydrogen gas are added to both the gas and toluene recycle streams. This combined stream is the cold-side feed to the process-to-process heat exchanger. The cold-side exit stream is then heated further up to the required reactor inlet temperature in the furnace, where heat is supplied via combustion of fuel.

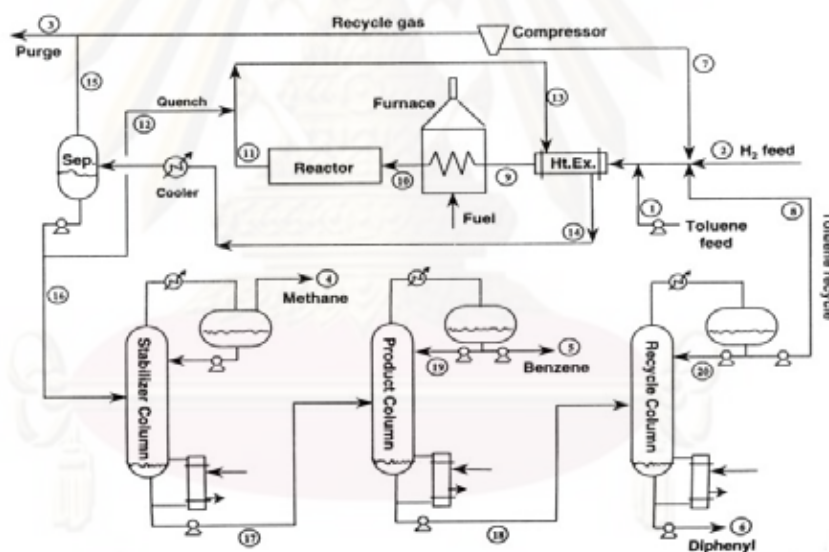

Figure 4.1 Hydrodealkylation (HDA) of toluene process

Component physical property data for the HDA process were obtained from William L. Luyben, Bjorn D. Tyreus, Michael L. Luyben (1999).

4.2 Alternatives of the Typical HDA Processes

Terrill and Douglas (1987) design six different energy-saving alternatives to the base case. The typical HDA process alternatives 1-6 are shown in Figure 4.2. The simplest of these designs, alternative 1, recovers an additional 29 percent of the base case heat consumption by making the reactor preheater larger and the furnace smaller.

Table 4.1 The energy saving from the energy integration of the typical HDA process

Typical HDA process	Alternatives					
	1	2	3	4	5	6
Utilities usage for alternatives, MW	9.1	7.7	7.4	7.3	7.3	7.3
Energy savings from new HEN, %	29	40	42	43	43	43
TAC for alternatives with base case design values, $\$10^6/\text{year}$	6.4	6.5	6.4	6.1	6.0	6.0

The energy savings from the energy integration as shown in Table 4.1 have between 29 and 43 percent. This work will consider the HDA process alternatives 5 and 6 which are complex heat-integrated HDA plant.

4.3 Design of Resilient Heat Exchanger Networks (RHEN) of the Typical HDA Processes

At this section, the heat exchanger networks for complex heat-integrated plant of HDA process used the design method of heat exchanger network which provided by Wongstri (1990). The problem table method is applied to find pinch temperature and reach maximum energy recovery (MER). The cost estimated will be consequence to compare and choose the best network that more optimal for the HDA process. The information for design is shown in Table 4.2.

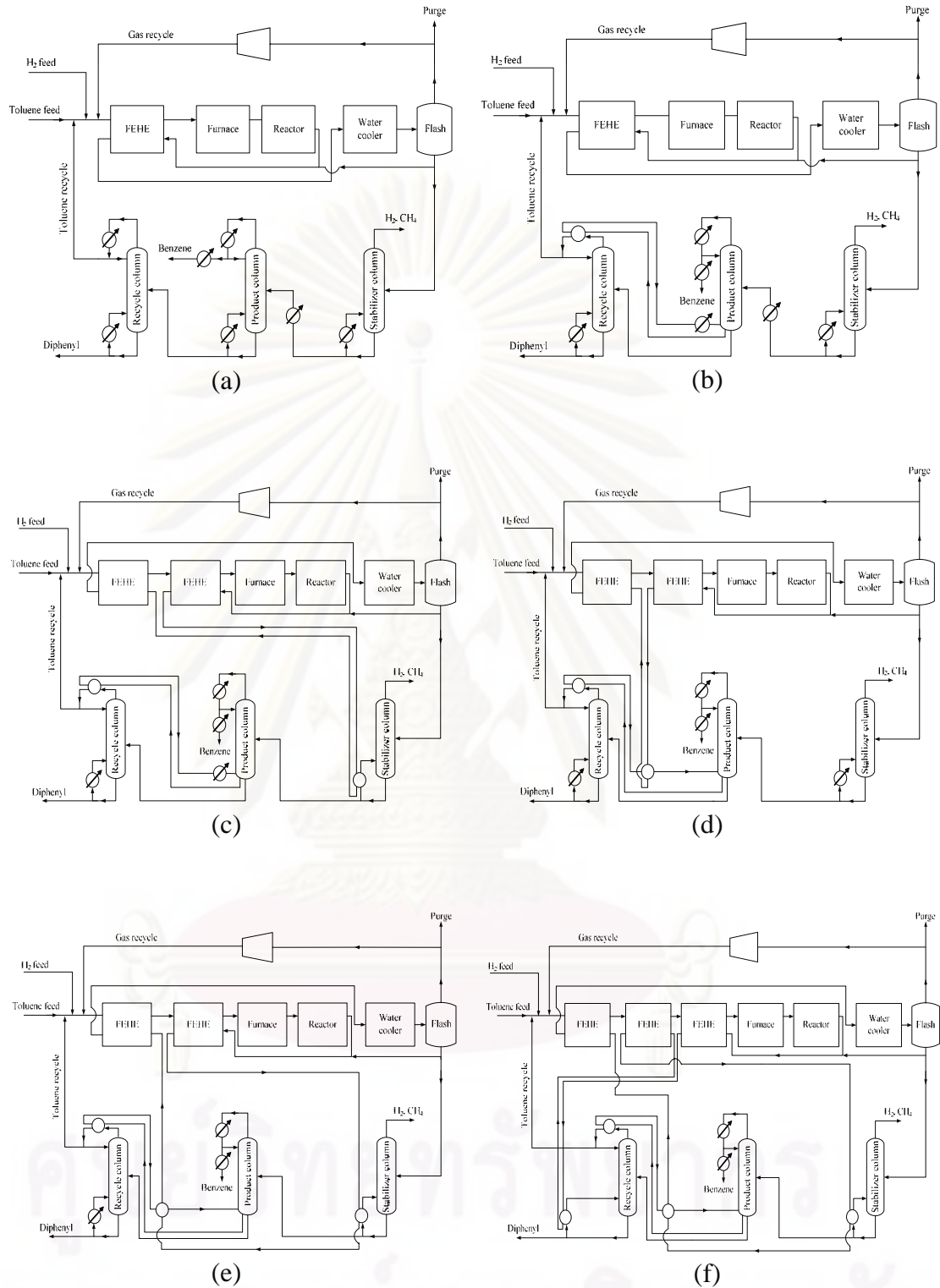
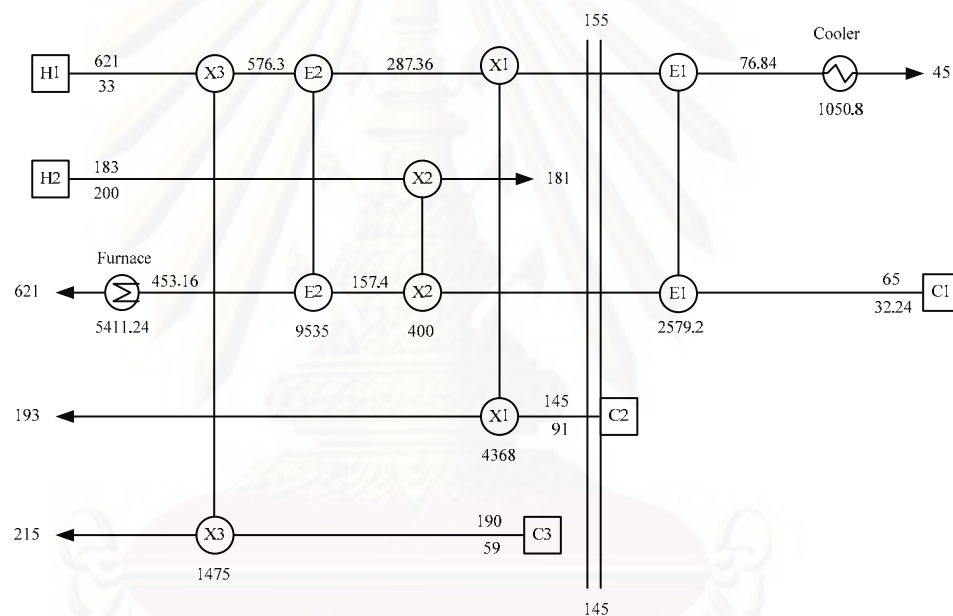

Figure 4.2 The six alternatives of the typical HDA process structures: (a) alternative 1 (b) alternative 2, (c) alternative 3, (d) alternative 4, (e) alternative 5, (f) alternative 6

Table 4.2 The information of the typical HDA process

Stream Name	T _{in} (°C)	T _{out} (°C)	W	Duty (kW)
H1 : Reactor Product Stream (RPS)	621	45	33	19008
H2 : Recycle Column Condenser (RCC)	183	181	200	400
C1 : Reactor Feed Stream (RFS)	65	621	32.24	17925.44
C2 : Product Column Reboiler (PCR)	145	193	91	4368
C3 : Stabilizer Column Reboiler (SCR)	190	215	59	1475
C4 : Recycle Column Reboiler (RCR)	349.5	350.7	456	547.2

4.3.1 The Resilient Heat Exchanger Network of HDA Process Alternative 5

**Figure 4.3** The resilient heat exchanger network alternative 5

The resilient heat exchanger network alternative 5 as shown in Figure 4.3, there are five streams in the network and the minimum temperature difference in the process-to-process-heat-exchangers ΔT_{\min} is set at 10°C.

We can find pinch temperature by using problem table method as shown in Table 4.3. At the minimum heat load condition, the pinch temperature occurs at 155/145°C. The minimum utility requirements have been predicted 5,411.24 kW/hr of hot utilities and 1,050.8 kW/hr of cold utilities.

Table 4.3 Problem table for alternative 5

W					T (°C)		ΔT	Sum W	Require	Interval	Cascade	Sum Interval
H1	H2	C1	C2	C3	Hot	Cold						
0	0	0	0	0	631	621			Qh			
0	0	32.24	0	0	621	611	10	-32.24	5411.24	-322.4	5088.84	-322.4
33	0	32.24	0	0	225	215	396	0.76	5088.84	300.96	5389.8	-21.44
33	0	32.24	0	59	203	193	22	-58.24	5389.8	-1281.28	4108.52	-1302.72
33	0	32.24	91	59	200	190	3	-149.24	4108.52	-447.72	3660.8	-1750.44
33	0	32.24	91	0	183	173	17	-90.24	3660.8	-1534.08	2126.72	-3284.52
33	200	32.24	91	0	181	171	2	109.76	2126.72	219.52	2346.24	-3065
33	0	32.24	91	0	155	145	26	-90.24	2346.24	-2346.24	0	-5411.24
33	0	32.24	0	0	75	65	80	0.76	0	60.8	60.8	-5350.44
33	0	0	0	0	45	35	30	33	60.8	990	1050.8	-4360.44
											Qc	

The disturbance propagation method and math pattern are used for the synthesis procedure which is shown in Table 4.4 and 4.5.

Table 4.4 Synthesis table for cold end of alternative 5

Synthesis table for cold end of alternative 5							
Stream	Load	W	T1	T2	D1	D2	Action
a) state 1							
H1	3960	33	165	45	330	0	select B[C]
C1	2579.2	32.24	75	155	322.4	322.4	selected
b) state 2							
H1	1380.8	33	86.8424242	45	330	0	to cooler
C1							matched to H1

Table 4.5 Synthesis table for hot end of alternative 5

Synthesis table for hot end of alternative 5							
Stream	Load	W	T1	T2	D1	D2	Action
a) state 1							
H1	14718	33	611	165	330	330	selected C[H]
H2	200	200	182	181	200	0	
C1	15023.84	32.24	155	621	0	322.4	
C2	3458	91	155	193	0	910	selected
C3	885	59	200	215	0	590	
b) state 2							
H1	11260	33	611	269.7878788	330	0	

H2	200	200	182	181	200	0	selected A[H]
C1	15023.84	32.24	155	621	0	322.4	selected
C2					0	580	to heater
C3	885	59	200	215	0	590	
c) state 3							
H1	11260	33	611	269.7878788	330	0	selected B[C]
H2							matched to C1
C1	14823.84	32.24	161.2034739	621	0	522.4	
C3	885	59	200	215	0	590	selected
d) state 4							
H1	10375	33	584.1818182	269.7878788	920	0	selected AH
C1	14823.84	32.24	161.2034739	621	0	522.4	selected
C3							matched to H1
e) state 5							
H1							matched to C1
C1	4448.84	32.24	483.0086849	621	0	1442.4	to heater

4.3.2 The Resilient Heat Exchanger Network of HDA Process Alternative 6

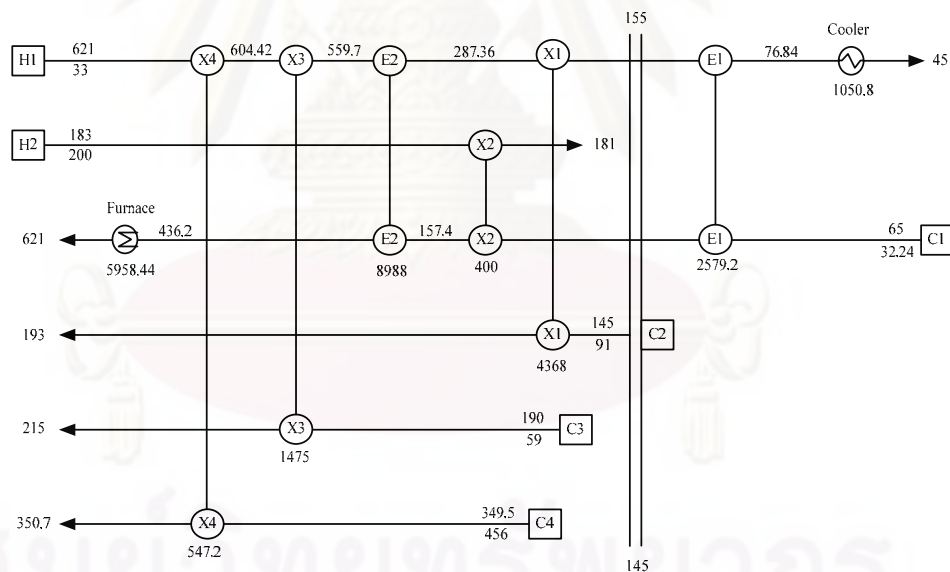

Figure 4.4 The resilient heat exchanger network alternative 6

The resilient heat exchanger network alternative 6 as shown in Figure 4.4, there are six streams in the network and the minimum temperature difference in the process-to-process-heat-exchangers ΔT_{\min} is set at 10°C .

We can find pinch temperature by using problem table method as shown in Table 4.6. At the minimum heat load condition, the pinch temperature occurs at

155/145°C. The minimum utility requirements have been predicted 5,958.44 kW/hr of hot utilities and 1,050.8 kW/hr of cold utilities.

Table 4.6 Problem table for alternative 6

W						T (°C)		ΔT	Sum W	Require	Interval	Cascade	Sum Interval
H1	H2	C1	C2	C3	C4	Hot	Cold						
0	0	0	0	0	0	631	621			Qh			
0	0	32.24	0	0	0	621	611	10	-32.24	5958.44	-322.4	5636.04	-322.4
33	0	32.24	0	0	0	360.7	350.7	260.3	0.76	5636.04	197.83	5833.87	-124.57
33	0	32.24	0	0	456	359.5	349.5	1.2	-455.24	5833.87	-546.29	5287.58	-670.86
33	0	32.24	0	0	0	225	215	134.5	0.76	5287.58	102.22	5389.8	-568.64
33	0	32.24	0	59	0	203	193	22	-58.24	5389.8	-1281.28	4108.52	-1849.92
33	0	32.24	91	59	0	200	190	3	-149.24	4108.52	-447.72	3660.8	-2297.64
33	0	32.24	91	0	0	183	173	17	-90.24	3660.8	-1534.08	2126.72	-3831.72
33	200	32.24	91	0	0	181	171	2	109.76	2126.72	219.52	2346.24	-3612.2
33	0	32.24	91	0	0	155	145	26	-90.24	2346.24	-2346.24	0	-5958.44
33	0	32.24	0	0	0	75	65	80	0.76	0	60.8	60.8	-5897.64
33	0	0	0	0	0	45	35	30	33	60.8	990	1050.8	-4907.64
												Qc	

The disturbance propagation method and math pattern are used for the synthesis procedure which is shown in Table 4.7 and 4.8.

Table 4.7 Synthesis table for cold end of alternative 6

Synthesis table for cold end of alternative 6							
Stream	Load	W	T1	T2	D1	D2	Action
a) state 1							
H1	3960	33	165	45	330	0	select B[C]
C1	2579.2	32.24	75	155	322.4	322.4	selected
b) state 2							
H1	1380.8	33	86.8424242	45	330	0	to cooler
C1							matched to H1

Table 4.8 Synthesis table for hot end of alternative 6

Synthesis table for hot end of alternative 6							
Stream	Load	W	T1	T2	D1	D2	Action
a) state 1							
H1	14718	33	611	165	330	330	selected C[H]
H2	200	200	182	181	200	0	

C1	15023.84	32.24	155	621	0	322.4	
C2	3458	91	155	193	0	910	selected
C3	885	59	200	215	0	590	
C4	319.2	456	350	350.7	0	228	
b) state 2							
H1	11260	33	611	269.7878788	330	0	
H2	200	200	182	181	200	0	selected A[H]
C1	15023.84	32.24	155	621	0	322.4	selected
C2					0	580	to heater
C3	885	59	200	215	0	590	
C4	319.2	456	350	350.7	0	228	
c) state 3							
H1	11260	33	611	269.7878788	330	0	selected B[C]
H2							matched to C1
C1	14823.84	32.24	161.2034739	621	0	522.4	
C3	885	59	200	215	0	590	
C4	319.2	456	350	350.7	0	228	selected
d) state 4							
H1	10940.8	33	601.3272727	269.7878788	558	0	selected B[C]
C1	14823.84	32.24	161.2034739	621	0	522.4	
C3	885	59	200	215	0	590	selected
C4							matched to H1
e) state 5							
H1	10055.8	33	574.5090909	269.7878788	1148	0	selected AH
C1	14823.84	32.24	161.2034739	621	0	522.4	selected
C3							matched to H1
f) state 6							
H1							matched to C1
C1	4768.04	32.24	473.1079404	621	0	1670.4	to heater

4.3.3 Heat-Integrated Structures of the Typical HDA Processes

The designs of six alternatives of heat exchanger networks (HENs) of the HDA processes are proposed to save energy from the alternative 1 (Base case). They are designed both simply and complex heat-integrated process.

In Figure 4.5 shows the simply heat-integrated of the typical HDA process alternative 1. We used a feed-effluent heat exchanger (FEHE) to reduce the amount of fuel burned in the furnace. The heat of reaction and the heat added in the furnace are therefore removed in the flooded condenser.

In alternative 1 (see Figure 4.5), the simplest of these design recovers an additional 29 percent of the base case heat consumption by making the reactor preheater larger and the furnace smaller.

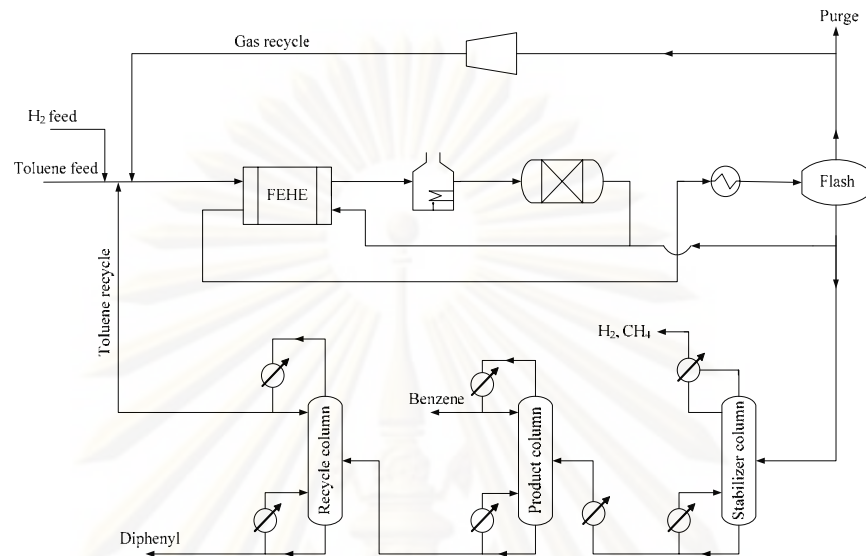

Figure 4.5 The typical HDA process alternative 1 (Base case)

In alternative 5 (see Figure 4.6), both the stabilizer and product column reboiler are driven consecutively by the reactor effluent stream. The recycle column was pressure shifted to be above the pinch temperature.

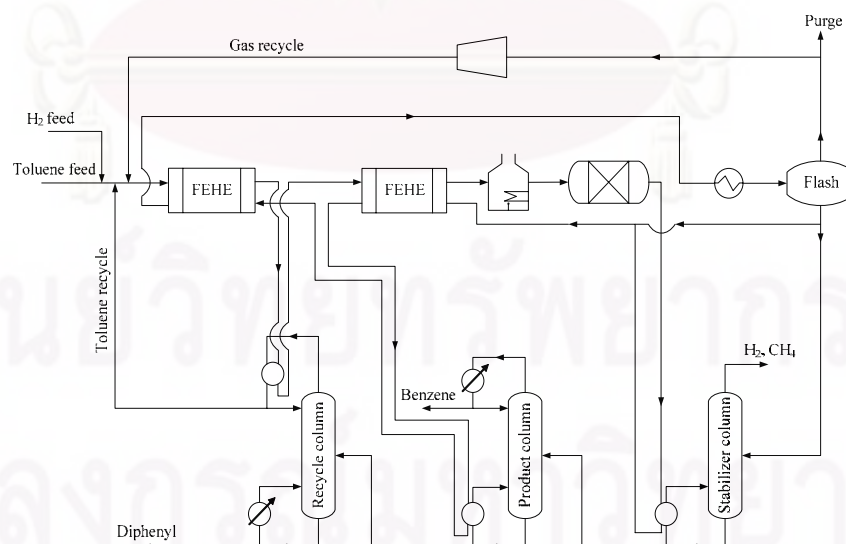

Figure 4.6 The typical HDA process alternative 5

In the alternative 6 (see Figure 4.7), all three column reboilers are driven by the reactor effluent stream. The recycle column was pressure shifted to be above the pinch temperature.

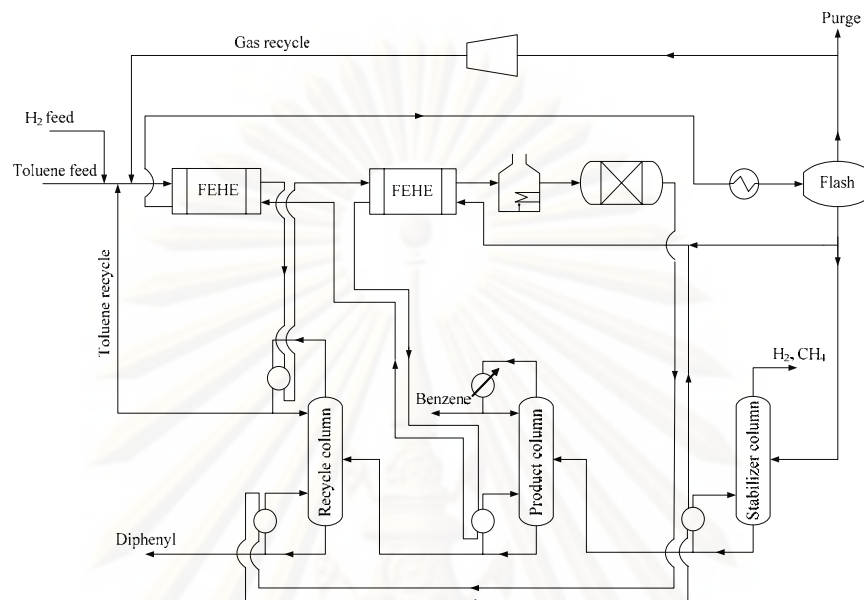

Figure 4.7 The typical HDA process alternative 6

4.4 Steady State Model of the Typical HDA Processes

First, a steady-state model is built in HYSYS.PLANT, using the flowsheet and equipment design information, mainly taken from Douglas (1988); Luyben et al. (1998) to develop for the typical HDA process alternative 1 (Base case), 5 and 6. Figure 4.8, 4.9 and 4.10 show the HYSYS flowsheets of the simply heat-integrated of the typical HDA process alternatives 1 (Base case) and the complex heat-integrated of the typical HDA process alternative 5 and 6, respectively. For our simulation, Peng-Robinson model is selected for physical property calculations because of its reliability in predicting the properties of most hydrocarbon-based fluids over a wide range of operating conditions. The reaction kinetics of both reactions are modeled with standard Arrhenius kinetic expressions available in HYSYS.PLANT, and the kinetic data are taken from Luyben et al. (1998). Since there are many material recycles, as RECYCLE operations in HYSYS are inserted in the streams. Proper initial values should be chosen for these streams, otherwise the iterative calculations might

converge to another steady-state due to the non-linearity and unstable characteristics of the process.

When columns are modeled in steady-state, besides the specification of inlet streams, pressure profiles, numbers of trays and feed tray, two specifications need to be given for columns with both condenser and reboiler. These could be the duties, reflux rate, draw stream rates, composition fractions, etc. We chose reflux ratio and overhead benzene mole fraction for the stabilizer column. For the remaining two columns, bottom and overhead composition mole fractions are specified to meet the required purity of products given in Douglas (1998). The tray sections of the columns are calculated using the tray sizing utility in HYSYS, which calculates tray diameter based on Glitsch design parameters for valve trays. Though the tray diameter and spacing, and weir length and height are not required in steady-state modeling, they are required for dynamic simulation.



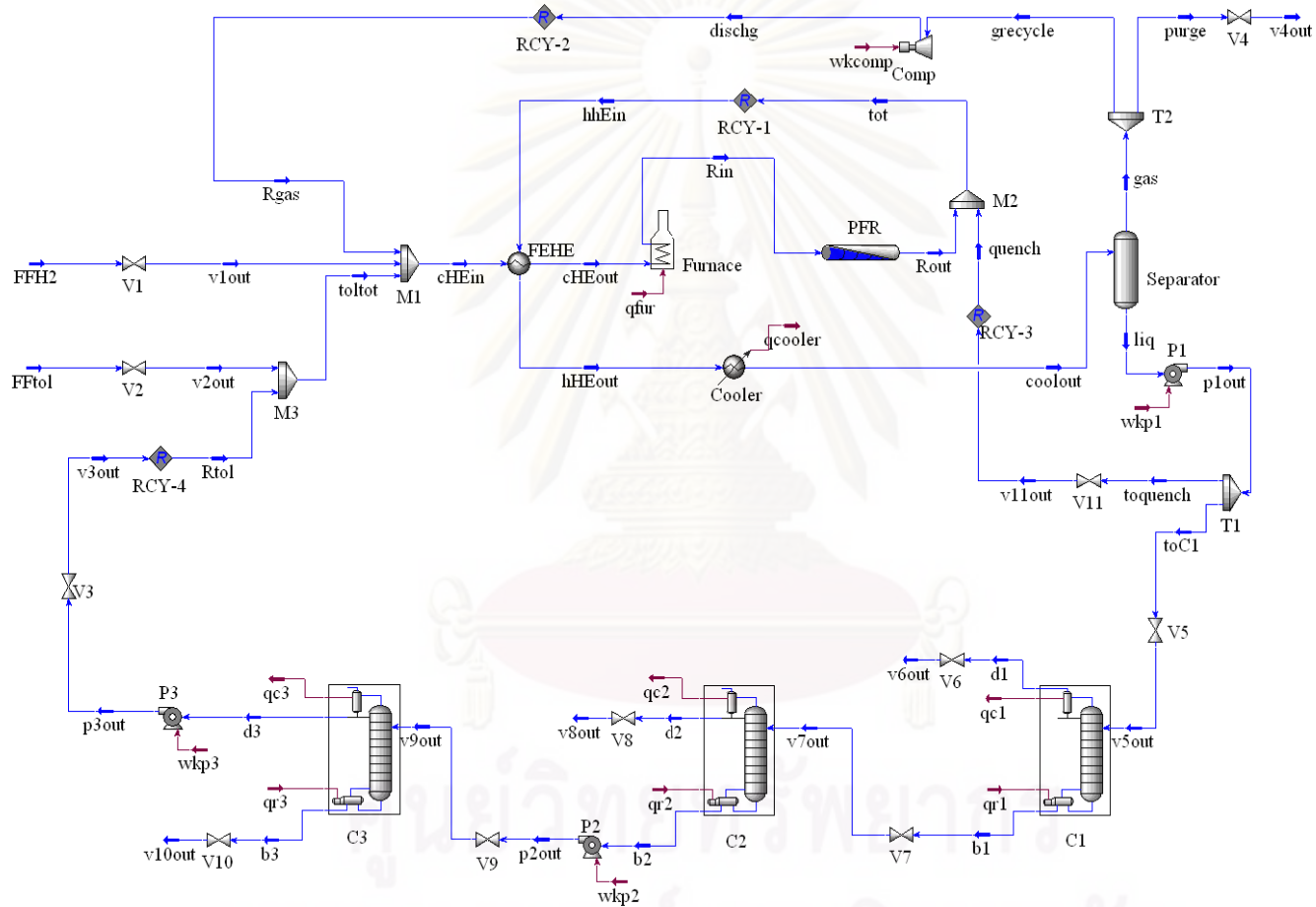

Figure 4.8 HYSYS flowsheet of the steady state model for the simply heat-integrated typical HDA process alternative 1 (Base case)

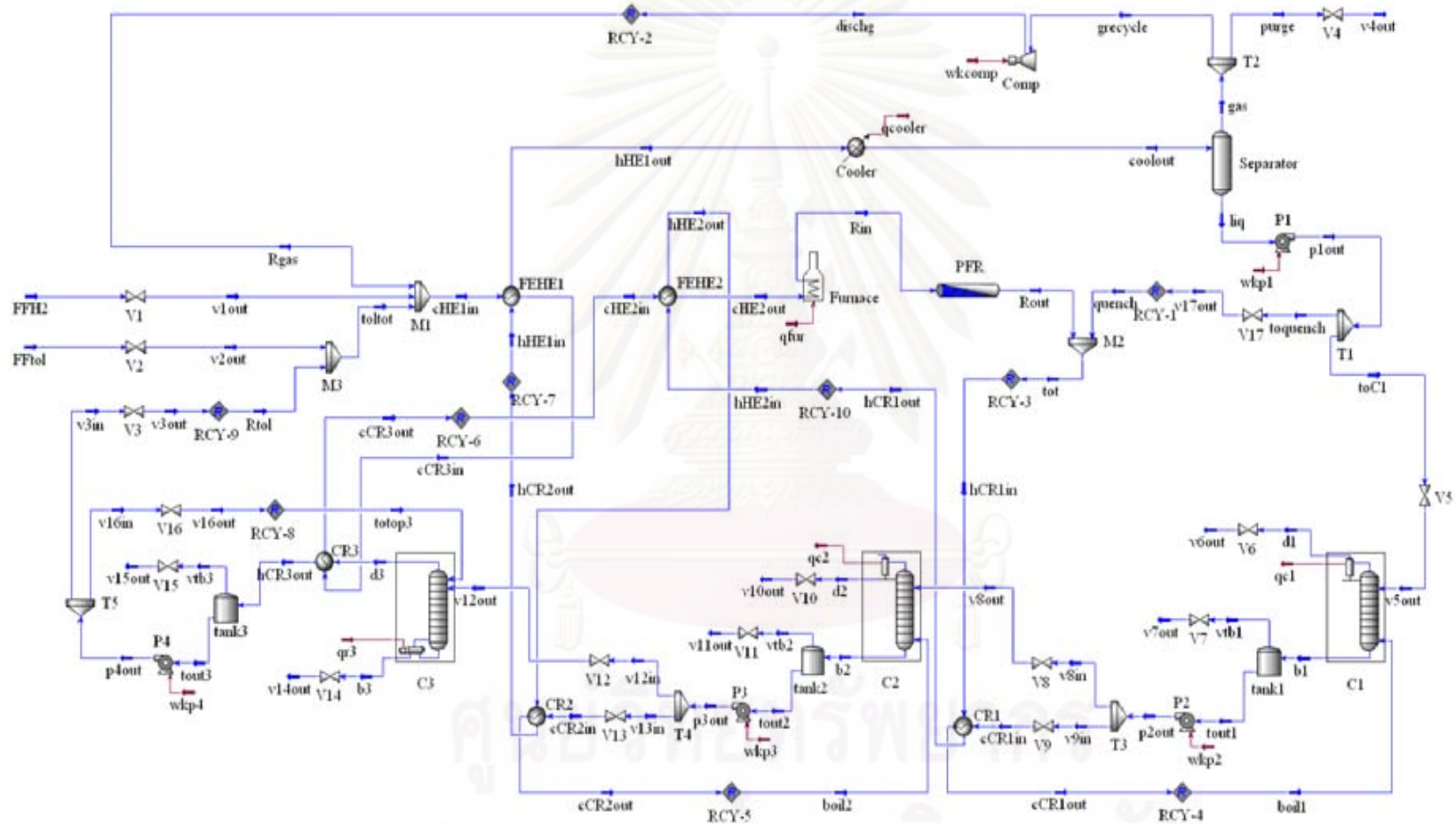

Figure 4.9 HYSYS flowsheet of the steady state model for the complex heat-integrated typical HDA process alternative 5

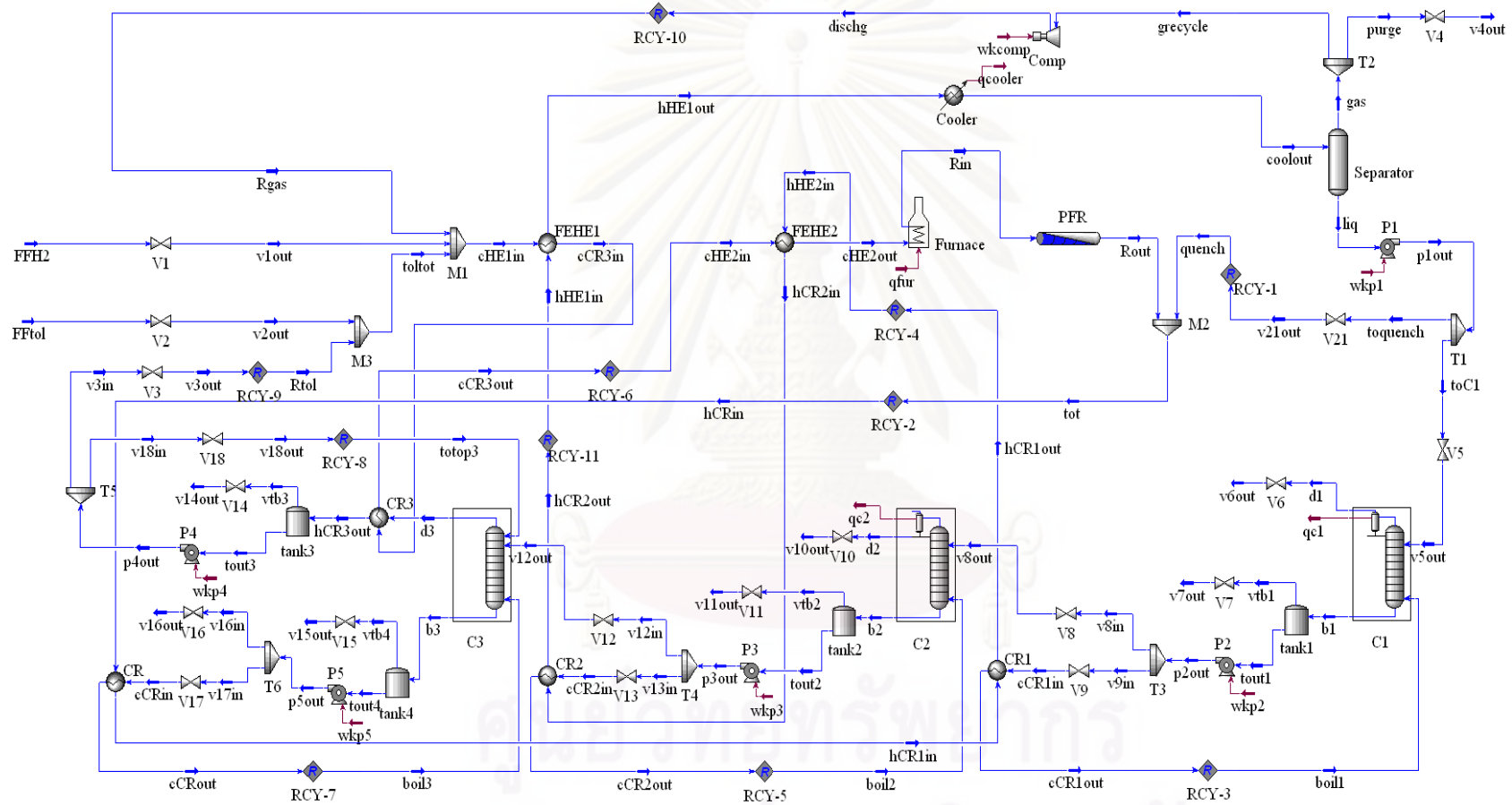

Figure 4.10 HYSYS flowsheet of the steady state model for the complex heat-integrated typical HDA process alternative 6

4.5 Energy Comparison of the Typical HDA Processes

From steady state simulations of the complex heat-integrated typical HDA process alternative 5 and 6, the energy savings that saved from the simply heat-integrated typical HDA process alternative 1 (Base case) are shown in Table 4.9. The complex heat-integrated typical HDA process alternative 5 and 6 are represented by HIP5.0 and HIP6.0, respectively.

Table 4.9 Energy savings of the typical HDA process (Steady state simulation)

Typical HDA process	Alternatives		
	AL 1 (BC)	HIP5.0	HIP6.0
Cooler	2197	1150	1152
Stabilizer Column Condenser	174.3	386.5	382.7
Product Column Condenser	4023.4	3787.3	3810.6
Recycle Column Condenser	430.4	0	0
Total Cold Utilities Usage, kW	6825.1	5323.8	5345.3
Furnace	383.6	3534	4135
Stabilizer Column Reboiler	1260.4	0	0
Product Column Reboiler	3429.3	0	0
Recycle Column Reboiler	474.3	584.2	0
Heater Product Reboiler	0	0	0
Total Hot Utilities Usage, kW	5547.6	4118.2	4135
Total Cold & Hot Utilities, kW	12372.7	9442	9480.3
Energy Saving %	0	23.69	23.38

CHAPTER V

THE NEW COMPLEX HEAT-INTEGRATED STRUCTURES FOR HDA PROCESS

The following assumptions are used to get the complex heat-integrated plant (HIP): (1) the flowrate and composition of fresh feed stream, product stream, recycle stream and purge stream are similar as the typical HDA process. (2) The flowrate and composition of the streams in the reaction part is similar as the typical HDA process.

5.1 Design of the Complex Heat-Integrated HDA Plant

In this work, we design only the separation part of the complex heat-integrated process (HIP) that is shown in Figure 5.1. In the new separation part (see Figure 5.1b), the stabilizer column separates hydrogen, methane and benzene as overhead product and benzene is the desired product from the product column. Toluene, as distillate and recycled back, is separated from diphenyl in recycle column.

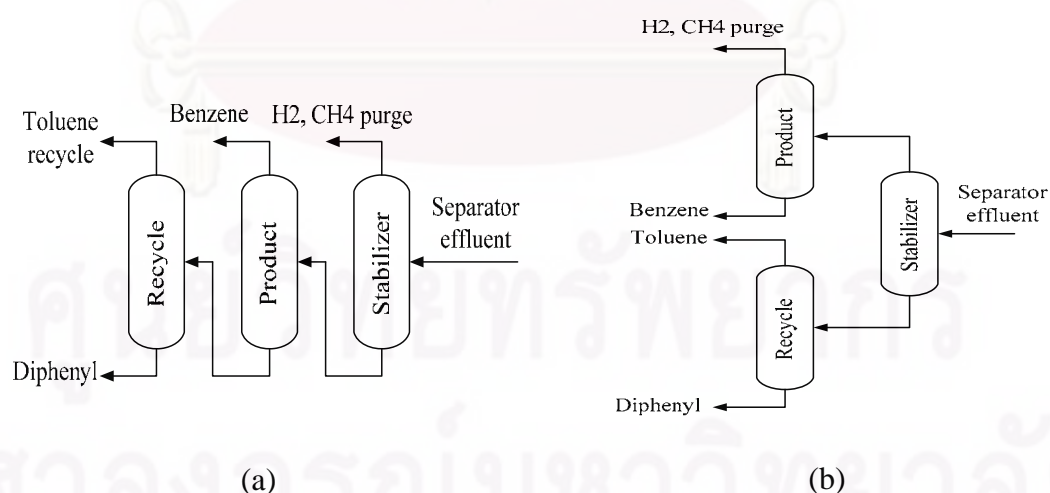

Figure 5.1 Separation section in the complex heat-integrated structure:(a) separation section in the typical HDA process, (b) new separation section in the HDA process

5.2 Design of Resilient Heat Exchanger Networks (RHEN) for Complex Heat-Integrated HDA Plant

At this section, the heat exchanger networks for complex heat-integrated plant (HIP) of HDA process used the design method of heat exchanger network which provided by Wongsri (1990). The problem table method is applied to find pinch temperature and reach maximum energy recovery (MER). The cost estimated will be consequence to compare and choose the best network that more optimal for the HDA process. The information for design is shown in Table 5.1.

Table 5.1 The information of complex heat-integrated plant (HIP) of HDA process

Stream Name	T _{in} (°C)	T _{out} (°C)	W	Duty (kW)
H1 : Reactor Product Stream (RPS)	621	45	33	19008
C1 : Reactor Feed Stream (RFS)	65	621	32.24	17925.4
C2 : Stabilizer Column Reboiler (SCR)	200.93	239.4	116.4	4477.9
C3 : Recycle Column Reboiler (RCR)	290.59	291.9	244.43	320.2
C4 : Product Column Reboiler (PCR)	153.3	155	104.18	177.1

5.2.1 The Resilient Heat Exchanger Network of Complex Heat-Integrated HDA Plant HIP5

There are four streams in the network. We can find pinch temperature by using problem table method as shown in Table 5.2.

Table 5.2 Problem table for HIP5

W				T (°C)		ΔT	Sum W	Require	Interval	Cascade	Sum Interval
H1	C1	C2	C3	Hot	Cold						
0	0	0	0	631	621			Q _h			
0	32.24	0	0	621	611	10	-32.24	4808.86	-322.4	4486.46	-322.4
33	32.24	0	0	301.9	291.9	319.1	0.76	4486.46	242.52	4728.98	-79.88
33	32.24	0	244.43	300.59	290.59	1.31	-243.67	4728.98	-319.21	4409.77	-399.09
33	32.24	0	0	249.4	239.4	51.19	0.76	4409.77	38.9	4448.67	-360.19
33	32.24	116.4	0	210.93	200.93	38.47	-115.64	4448.67	-4448.67	0	-4808.86
33	32.24	0	0	75	65	135.93	0.76	0	103.31	103.31	-4705.55
33	0	0	0	45	35	30	33	103.31	990	1093.31	-3715.55
										Q _c	

At the minimum heat load condition, the pinch temperature occurs at 210.93/200.93°C. The minimum utility requirements have been predicted 4,808.86 kW/hr of hot utilities and 1,093.31 kW/hr of cold utilities. By using Synthesis procedure (see Table 5.3, 5.4 and 5.5), we can receive two resilient heat exchanger networks. The two resilient heat exchanger networks HIP5 are represented by HIP5.1 and 5.2 as shown in Figure 5.2 and 5.3, respectively. The minimum temperature difference in the process-to-process-heat-exchangers, ΔT_{\min} is set at 10°C.

Table 5.3 Synthesis table for cold end of HIP5.1 and 5.2

Synthesis table for cold end of HIP 5.1 and 5.2							
Stream	Load	W	T1	T2	D1	D2	Action
a) state 1							
H1	5145.69	33	200.93	45	330	0	selected B[C]
C1	4059.98	32.24	75	200.93	322.4	322.4	selected
b) state 2							
H1	763.31	33	68.1305091	45	330	0	to cooler
C1							matched to H1

Table 5.4 Synthesis table for hot end of HIP5.1

Synthesis table for hot end of HIP 5.1							
Stream	Load	W	T1	T2	D1	D2	Action
a) state 1							
H1	13532.31	33	611	200.93	330	330	selected C[H]
C1	13220.66	32.24	210.93	621	0	322.4	
C2	4361.51	116.4	201.93	239.4	0	116.4	selected
C3	197.99	244.43	291.09	291.9	0	122.2	
b) state 2							
H1	9054.40	33	611	336.6241818	330	0	selected C[H]
C1	13220.66	32.24	210.93	621	0	322.4	
C2					0	213.6	to heater
C3	197.99	244.43	291.09	291.9	0	122.2	selected
c) state 3							
H1	8856.41	33	611	342.6238273	452.2	0	selected AH
C1	13220.66	32.24	210.93	621	0	322.4	selected
C3							matched to H1
d) state 4							
H1							matched to C1
C1	4364.24	32.24	485.6326582	621	0	774.6	to heater

Table 5.5 Synthesis table for hot end of HIP5.2

Synthesis table for hot end of HIP 5.2							
Stream	Load	W	T1	T2	D1	D2	Action
a) state 1							
H1	13532.31	33	611	200.93	330	330	selected C[H]
C1	13220.66	32.24	210.93	621	0	322.4	
C2	4361.51	116.4	201.93	239.4	0	116.4	selected
C3	197.99	244.43	291.09	291.9	0	122.2	
b) state 2							
H1	9054.40	33	611	336.6241818	330	0	selected B[C]
C1	13220.66	32.24	210.93	621	0	322.4	
C2					0	213.6	to heater
C3	197.99	244.43	291.09	291.9	0	122.2	selected
c) state 3							
H1	8856.41	33	605.0003545	336.6241818	452.2	0	selected AH
C1	13220.66	32.24	210.93	621	0	322.4	selected
C3							matched to H1
d) state 4							
H1							matched to C1
C1	4364.24	32.24	485.6326582	621	0	774.6	to heater

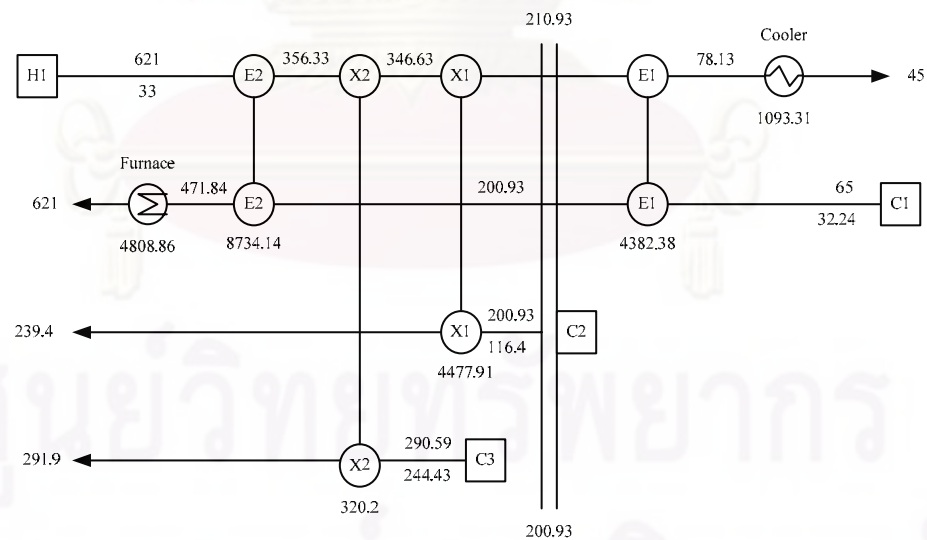
**Figure 5.2** The resilient heat exchanger network HIP5.1

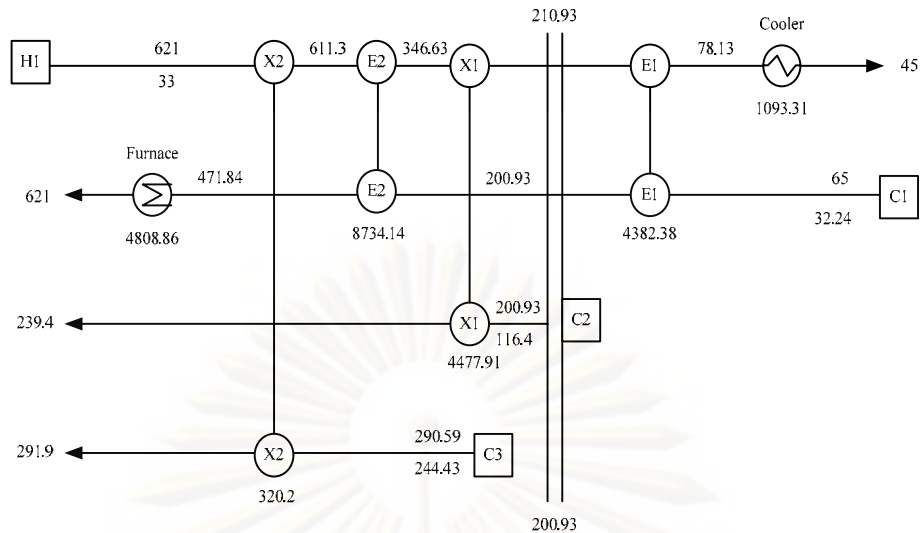

Figure 5.3 The resilient heat exchanger network HIP5.2

5.2.2 The Resilient Heat Exchanger Network of Complex Heat-Integrated HDA Plant HIP6

There are five streams in the network. We can find pinch temperature by using problem table method as shown in Table 5.6.

Table 5.6 Problem table for HIP6

W					T (°C)		ΔT	Sum W	Require	Interval	Cascade	Sum Interval
H1	C1	C2	C3	C4	Hot	Cold						
0	0	0	0	0	631	621			Qh			
0	32.24	0	0	0	621	611	10	-32.24	4949.77	-322.4	4627.37	-322.4
33	32.24	0	0	0	301.9	291.9	319.1	0.76	4627.37	242.52	4869.89	-79.88
33	32.24	0	244.43	0	300.59	290.59	1.31	-243.67	4869.89	-319.21	4550.68	-399.09
33	32.24	0	0	0	249.4	239.4	51.19	0.76	4550.68	38.9	4589.58	-360.19
33	32.24	116.4	0	0	210.93	200.93	38.47	-115.64	4589.58	-4448.67	140.91	-4808.86
33	32.24	0	0	0	165	155	45.93	0.76	140.91	34.91	175.82	-4773.95
33	32.24	0	0	104.18	163.3	153.3	1.7	-103.42	175.82	-175.81	0	-4949.77
33	32.24	0	0	0	75	65	88.3	0.76	0	67.11	67.11	-4882.66
33	0	0	0	0	45	35	30	33	67.11	990	1057.11	-3892.66
											Qc	

At the minimum heat load condition, the pinch temperature occurs at 163.3/153.3°C. The minimum utility requirements have been predicted 4,949.77 kW/hr of hot utilities and 1,057.11 kW/hr of cold utilities. By using Synthesis procedure (see Table 5.7, 5.8, 5.9 and 5.10), we can receive three resilient heat

exchanger networks. The three resilient heat exchanger networks HIP6 are represented by HIP6.1, 6.2 and 6.3 as shown in Figure 5.4, 5.5 and 5.6, respectively. The minimum temperature difference ΔT_{\min} is set at 10°C.

Table 5.7 Synthesis table for cold end of HIP6.1, 6.2 and 6.3

Synthesis table for cold end of HIP 6.1-6.3							
Stream	Load	W	T1	T2	D1	D2	Action
a) state 1							
H1	3573.9	33	153.3	45	330	0	selected B[C]
C1	2524.39	32.24	75	153.3	322.4	322.4	selected
b) state 2							
H1	727.11	33	67.0335758	45	330	0	to cooler
C1							matched to H1

Table 5.8 Synthesis table for hot end of HIP6.1

Synthesis table for hot end of HIP 6.1							
Stream	Load	W	T1	T2	D1	D2	Action
a) state 1							
H1	15104.1	33	611	153.3	330	330	selected C[H]
C1	14756.25	32.24	163.3	621	0	322.4	
C2	4361.51	116.4	201.93	239.4	0	116.4	
C3	197.99	244.43	291.09	291.9	0	122.2	
C4	72.93	104.18	154.3	155	0	104.18	selected
b) state 2							
H1	14926.99	33	611	158.6668485	330	0	selected C[H]
C1	14756.25	32.24	163.3	621	0	322.4	
C2	4361.51	116.4	201.93	239.4	0	116.4	selected
C3	197.99	244.43	291.09	291.9	0	122.2	
C4					0	225.82	to heater
c) state 3							
H1	10565.49	33	611	290.8337576	446.4	0	selected B[C]
C1	14756.25	32.24	163.3	621	0	322.4	
C2							matched to H1
C3	197.99	244.43	291.09	291.9	0	122.2	selected
d) state 4							
H1	10367.50	33	605.0003545	290.8337576	568.6	0	selected AH
C1	14756.25	32.24	163.3	621	0	322.4	selected
C3							matched to H1
e) state 5							
H1							matched to H1
C1	4388.75	32.24	484.8725093	621	0	891.0	to heater

Table 5.9 Synthesis table for hot end of HIP6.2

Synthesis table for hot end of HIP 6.2							
Stream	Load	W	T1	T2	D1	D2	Action
a) state 1							
H1	15104.1	33	611	153.3	330	330	selected C[H]
C1	14756.25	32.24	163.3	621	0	322.4	
C2	4361.51	116.4	201.93	239.4	0	116.4	selected
C3	197.99	244.43	291.09	291.9	0	122.2	
C4	72.93	104.18	154.3	155	0	104.18	
b) state 2							
H1	10626.19	33	611	288.9941818	330	0	selected C[H]
C1	14756.25	32.24	163.3	621	0	322.4	
C2					0	213.6	to heater
C3	197.99	244.43	291.09	291.9	0	122.2	selected
C4	72.93	104.18	154.3	155	0	104.18	
c) state 3							
H1	10428.20	33	611	294.9938273	452.2	0	selected B[C]
C1	14756.25	32.24	163.3	621	0	322.4	
C3							matched to H1
C4	72.93	104.18	154.3	155	0	104.18	selected
d) state 4							
H1	10355.28	33	608.7901212	294.9938273	556.4	0	selected AH
C1	14756.25	32.24	163.3	621	0	322.4	selected
C4							matched to H1
e) state 5							
H1							matched to C1
C1	4400.97	32.24	484.493477	621	0	878.8	to heater

Table 5.10 Synthesis table for hot end of HIP6.3

Synthesis table for hot end of HIP 6.3							
Stream	Load	W	T1	T2	D1	D2	Action
a) state 1							
H1	15104.1	33	611	153.3	330	330	selected C[H]
C1	14756.25	32.24	163.3	621	0	322.4	
C2	4361.51	116.4	201.93	239.4	0	116.4	selected
C3	197.99	244.43	291.09	291.9	0	122.2	
C4	72.93	104.18	154.3	155	0	104.18	
b) state 2							
H1	10626.19	33	611	288.9941818	330	0	selected C[H]
C1	14756.25	32.24	163.3	621	0	322.4	
C2					0	213.6	to heater

C3	197.99	244.43	291.09	291.9	0	122.2	
C4	72.93	104.18	154.3	155	0	104.18	selected
c) state 3							
H1	10553.27	33	608.7901212	288.9941818	434.2	0	selected B[C]
C1	14756.25	32.24	163.3	621	0	322.4	
C3	197.99	244.43	291.09	291.9	0	122.2	selected
C4							matched to H1
d) state 4							
H1	10355.28	33	602.7904758	288.9941818	556.4	0	selected AH
C1	14756.25	32.24	163.3	621	0	322.4	selected
C3							matched to H1
e) state 5							
H1							matched to C1
C1	4400.97	32.24	484.493477	621	0	878.8	to heater

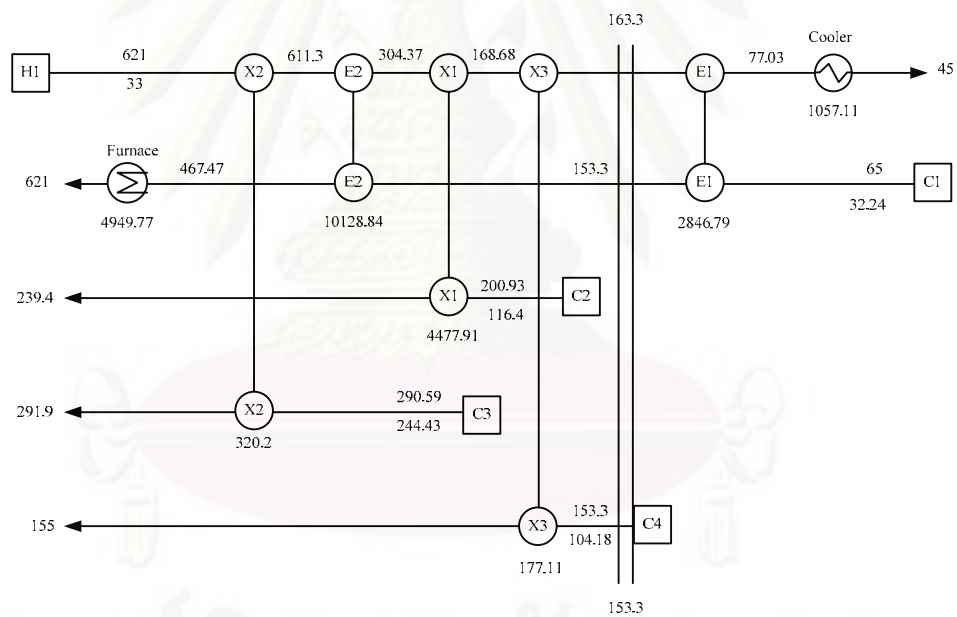

Figure 5.4 The resilient heat exchanger network HIP6.1

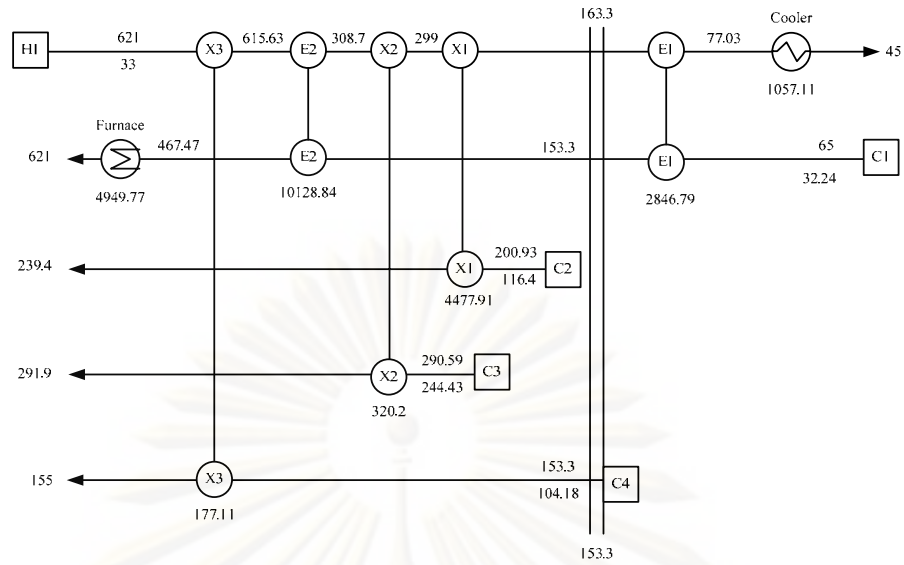

Figure 5.5 The resilient heat exchanger network HIP6.2

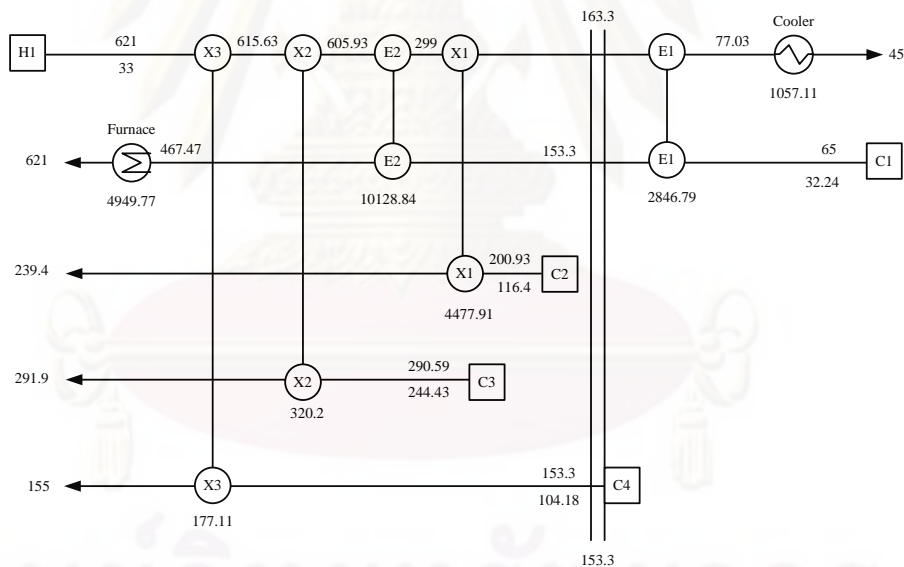

Figure 5.6 The resilient heat exchanger network HIP6.3

5.3 Complex Heat-Integrated Structures of HDA Process

The designs of six alternatives of heat exchanger networks (HENs) of the HDA processes are proposed to save energy from the heat-integrated plant HIP1. They are designed both simply and complex heat-integrated process.

In Figure 5.7 shows the simply heat-integrated of HDA process (HIP1). We used a feed-effluent heat exchanger (FEHE) to reduce the amount of fuel burned in the furnace. The heat of reaction and the heat added in the furnace are therefore removed in the flooded condenser.

In HIP1 (see Figure 5.7), the simplest of these design heat consumption by making the reactor preheater larger and the furnace smaller.

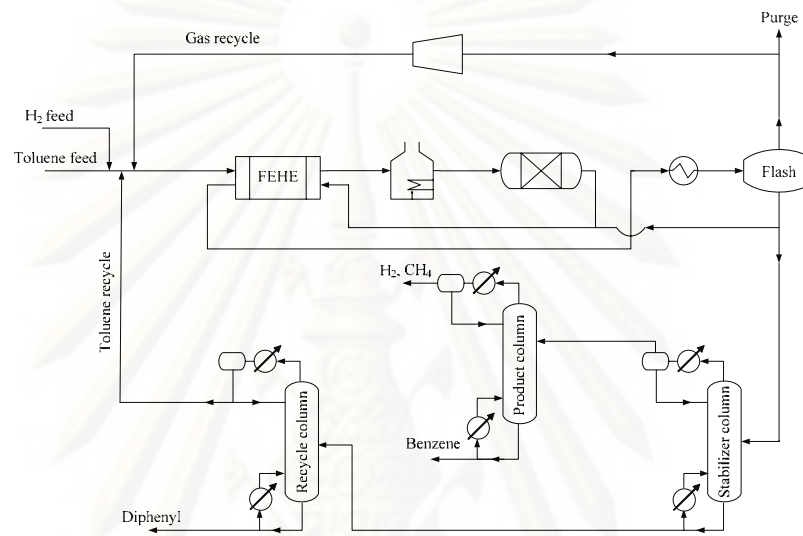

Figure 5.7 The heat-integrated structure of HDA process, HIP1

In HIP5.1 and 5.2 as see in Figure 5.8 and 5.9 respectively, both the stabilizer and recycle column reboiler are driven consecutively by the reactor effluent stream.

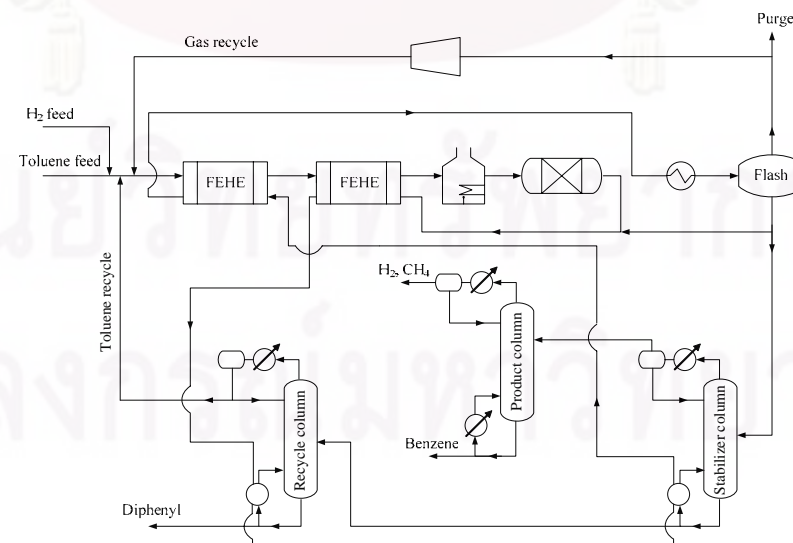

Figure 5.8 The heat-integrated structure of HDA process, HIP5.1

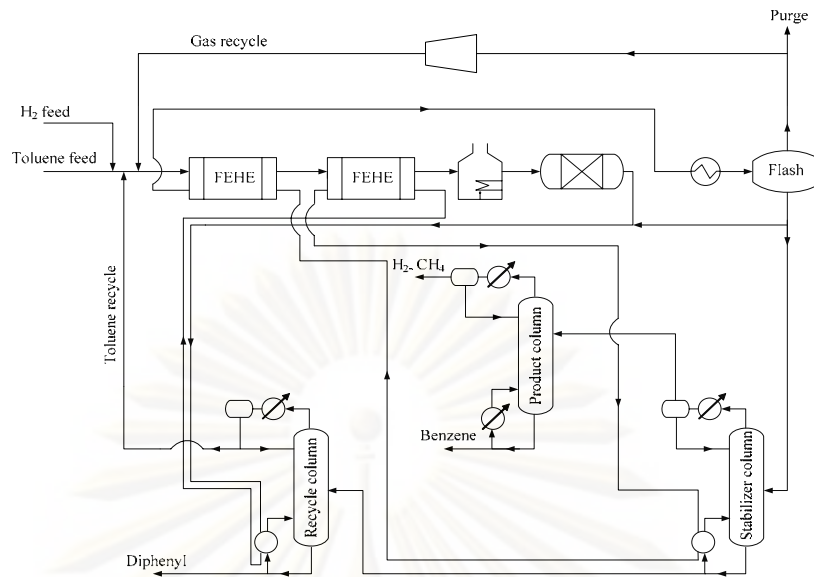

Figure 5.9 The heat-integrated structure of HDA process, HIP5.2

In HIP6.1, 6.2 and 6.3 as see in Figure 5.10, 5.11 and 5.12 respectively, all three column (stabilizer, product and recycle column) are driven consecutively by the reactor effluent stream.

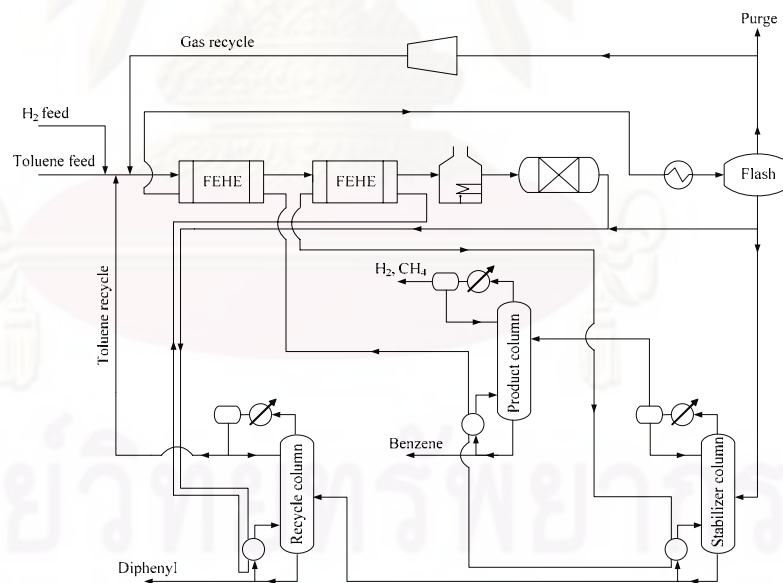

Figure 5.10 The heat-integrated structure of HDA process, HIP6.1

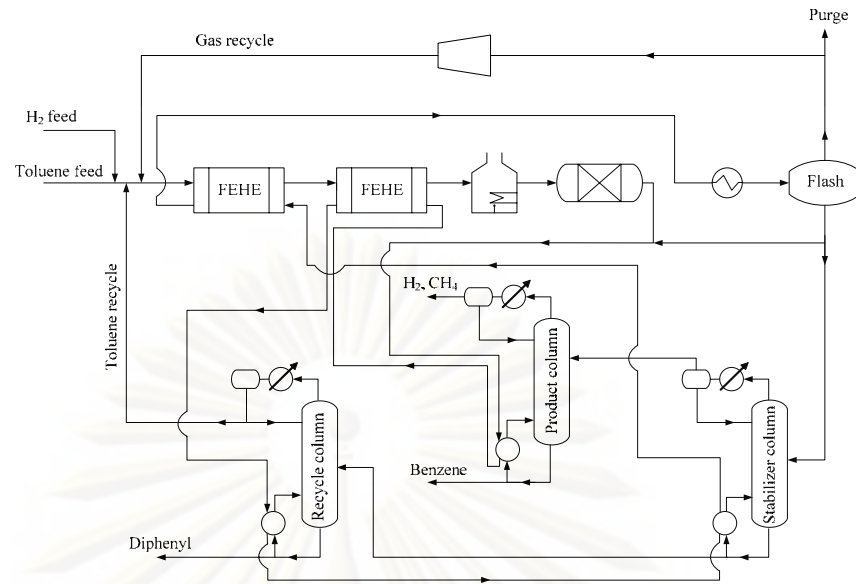

Figure 5.11 The heat-integrated structure of HDA process, HIP6.2

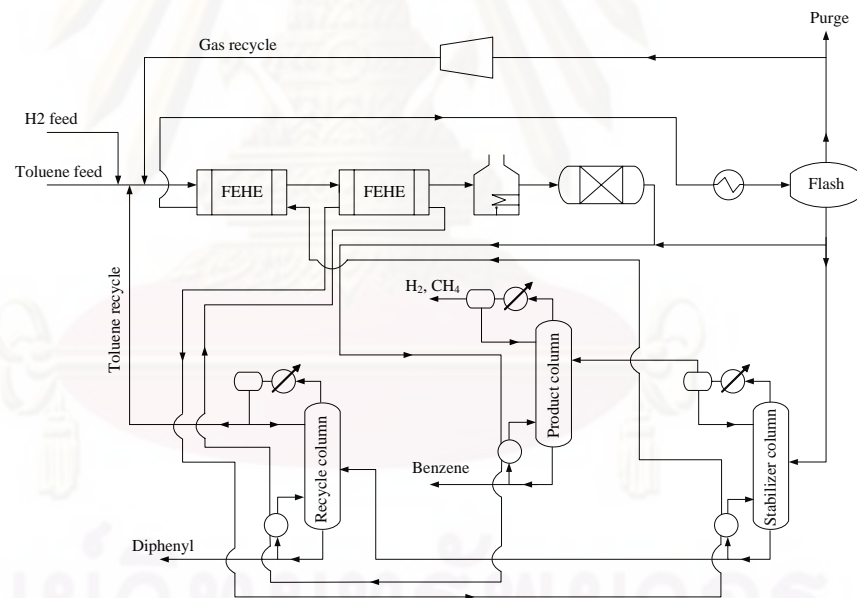

Figure 5.12 The heat-integrated structure of HDA process, HIP6.3

5.4 Steady State Model of Complex Heat-Integrated HDA Plant

First, a steady-state model is built in HYSYS.PLANT, using the flowsheet and equipment design information, mainly taken from Douglas (1988); Luyben et al. (1998) to develop for the HDA process HIP1, 5.1, 5.2, 6.1, 6.2 and 6.3. Figure 5.13, 5.14, 5.15, 5.16, 5.17 and 5.18 show the HYSYS flowsheets of the simply heat-integrated HDA plant HIP1 (Base case) and the complex heat-integrated HDA plant HIP5.1, 5.2, 6.1, 6.2 and 6.3, respectively. For our simulation, Peng-Robinson model is selected for physical property calculations because of its reliability in predicting the properties of most hydrocarbon-based fluids over a wide range of operating conditions. The reaction kinetics of both reactions are modeled with standard Arrhenius kinetic expressions available in HYSYS.PLANT, and the kinetic data are taken from Luyben et al. (1998). Since there are many material recycles, as RECYCLE operations in HYSYS are inserted in the streams. Proper initial values should be chosen for these streams, otherwise the iterative calculations might converge to another steady-state due to the non-linearity and unstable characteristics of the process.

When columns are modeled in steady-state, besides the specification of inlet streams, pressure profiles, numbers of trays and feed tray, two specifications need to be given for columns with both condenser and reboiler. These could be the duties, reflux rate, draw stream rates, composition fractions, etc. We chose reflux ratio and overhead benzene mole fraction for the stabilizer column. For the remaining two columns, bottom and overhead composition mole fractions are specified to meet the required purity of products given in Douglas (1998). The tray sections of the columns are calculated using the tray sizing utility in HYSYS, which calculates tray diameter based on Glitsch design parameters for valve trays. Though the tray diameter and spacing, and weir length and height are not required in steady-state modeling, they are required for dynamic simulation.

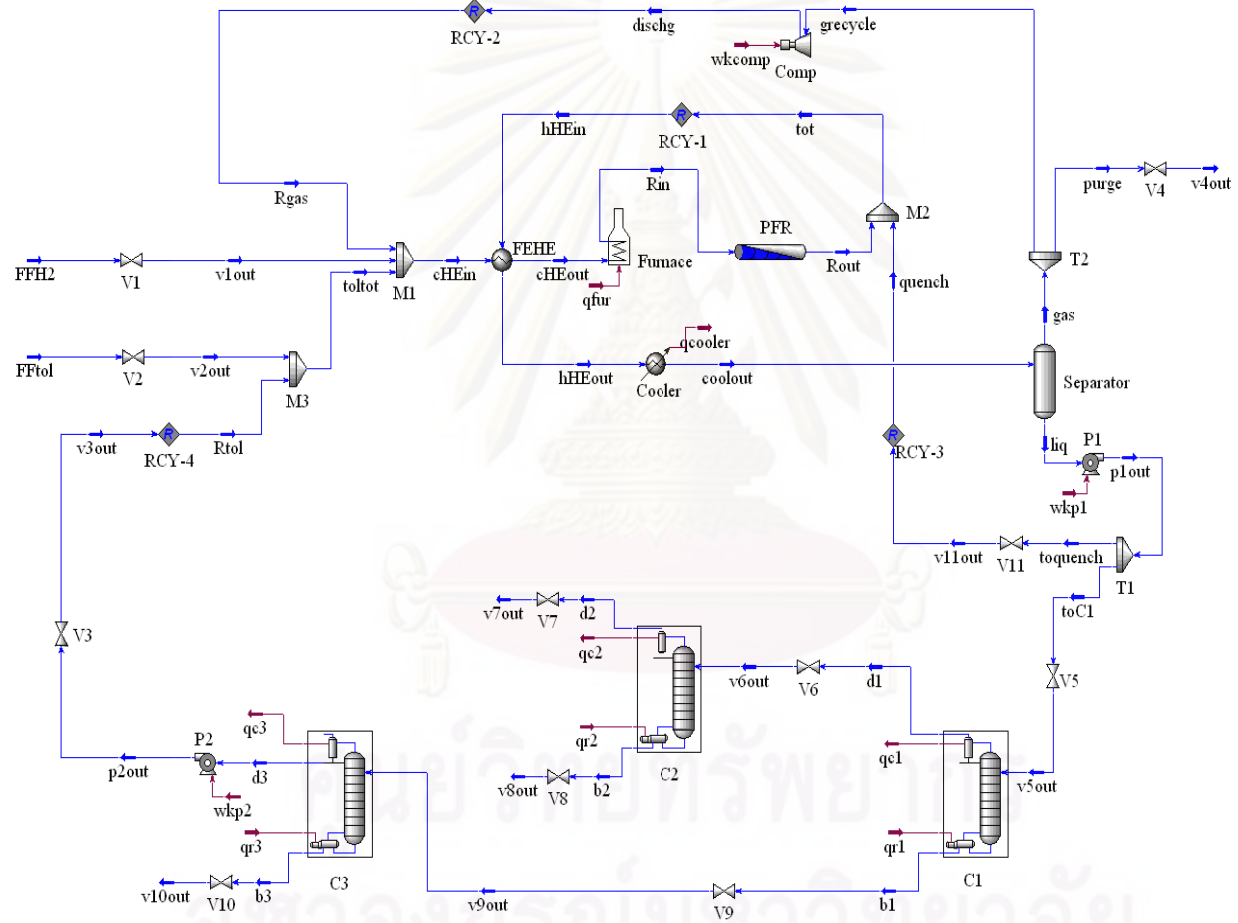

Figure 5.13 HYSYS flowsheet of the steady state model of the simply heat-integrated HDA plant HIP1

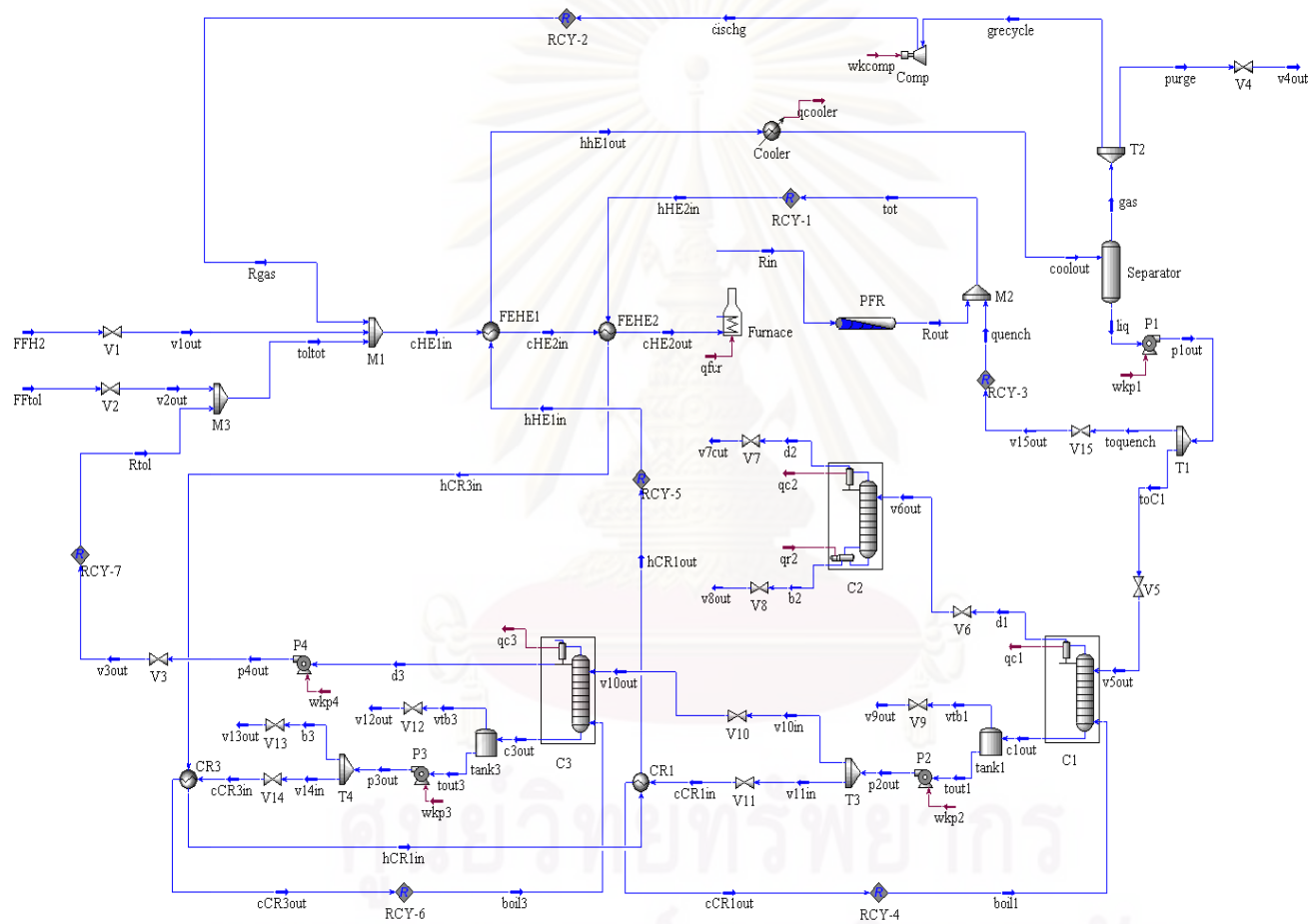

Figure 5.14 HYSYS flowsheet of the steady state model of the complex heat-integrated HDA plant HIP5.1

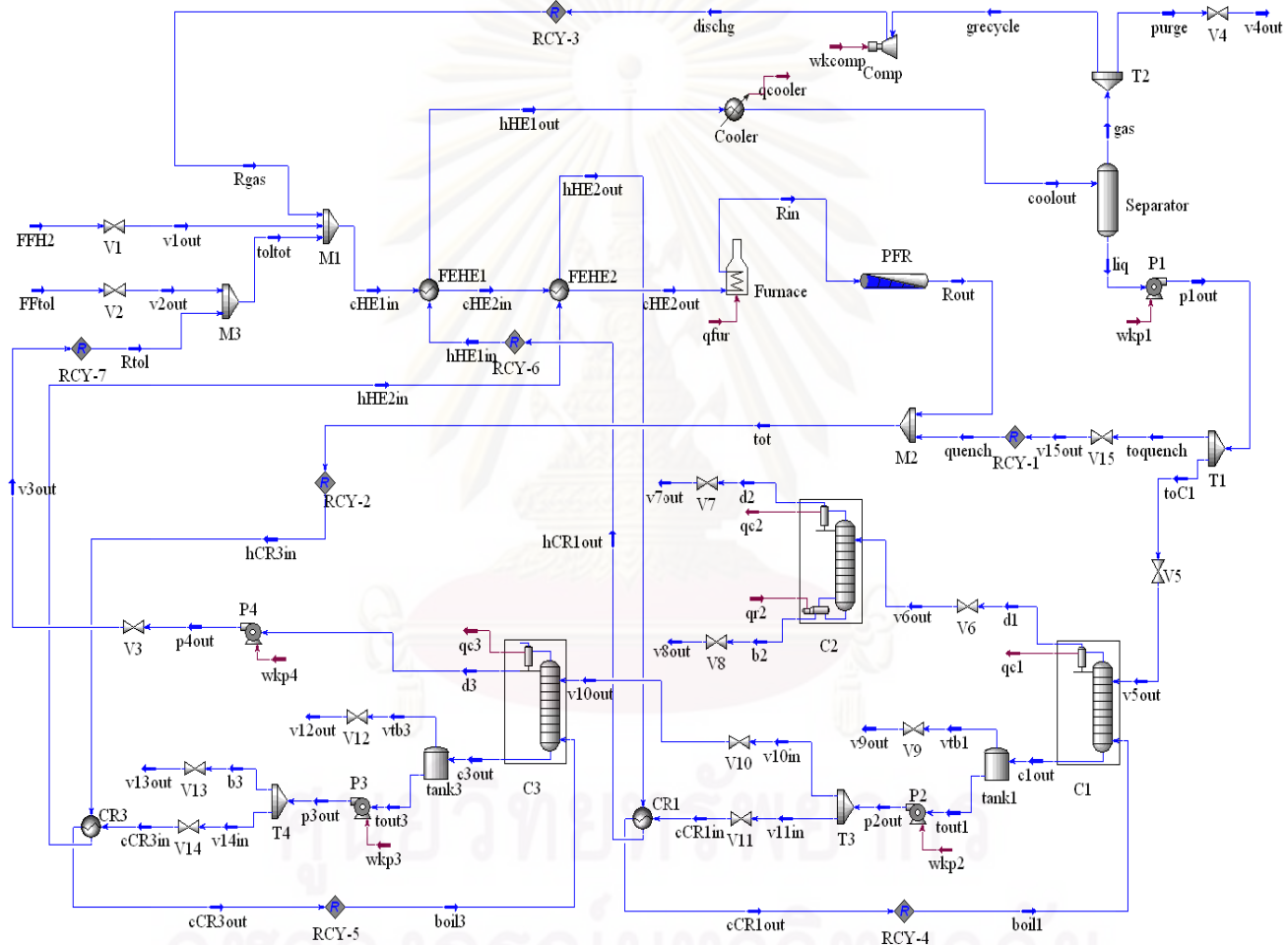

Figure 5.15 HYSYS flowsheet of the steady state model of the complex heat-integrated HDA plant HIP5.2

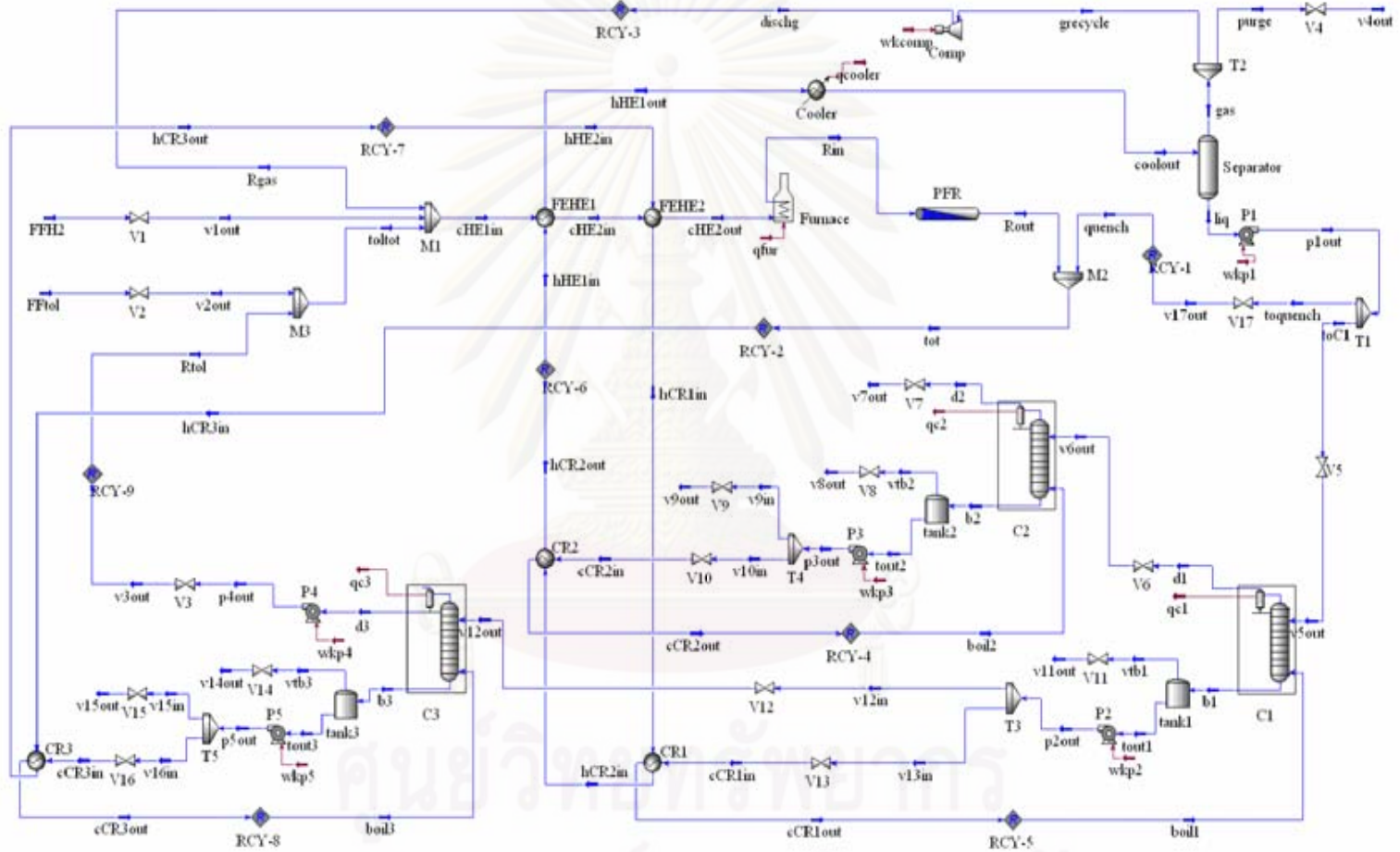

Figure 5.16 HYSYS flowsheet of the steady state model of the complex heat-integrated HDA plant HIP6.1

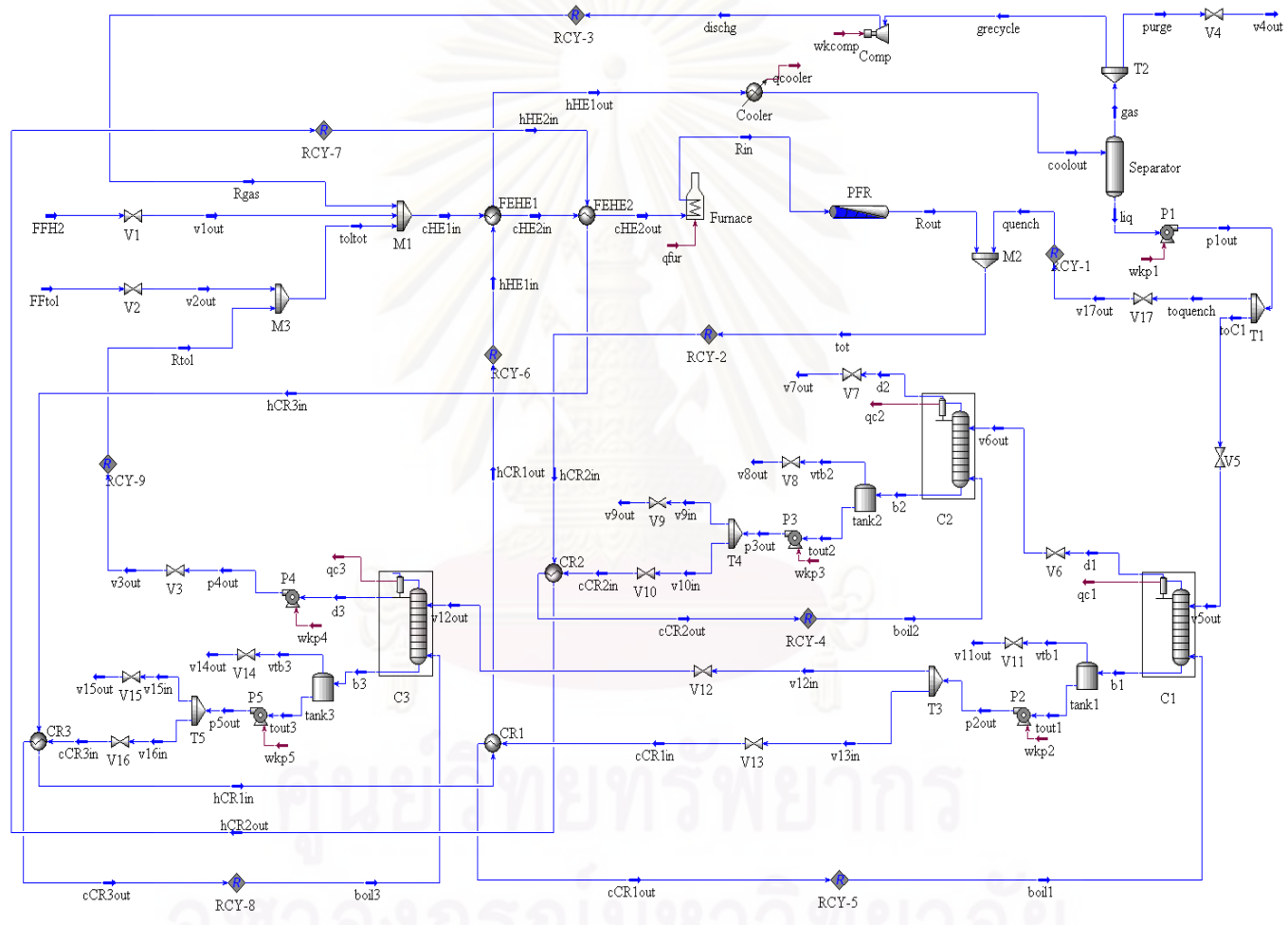

Figure 5.17 HYSYS flowsheet of the steady state model of the complex heat-integrated HDA plant HIP6.2

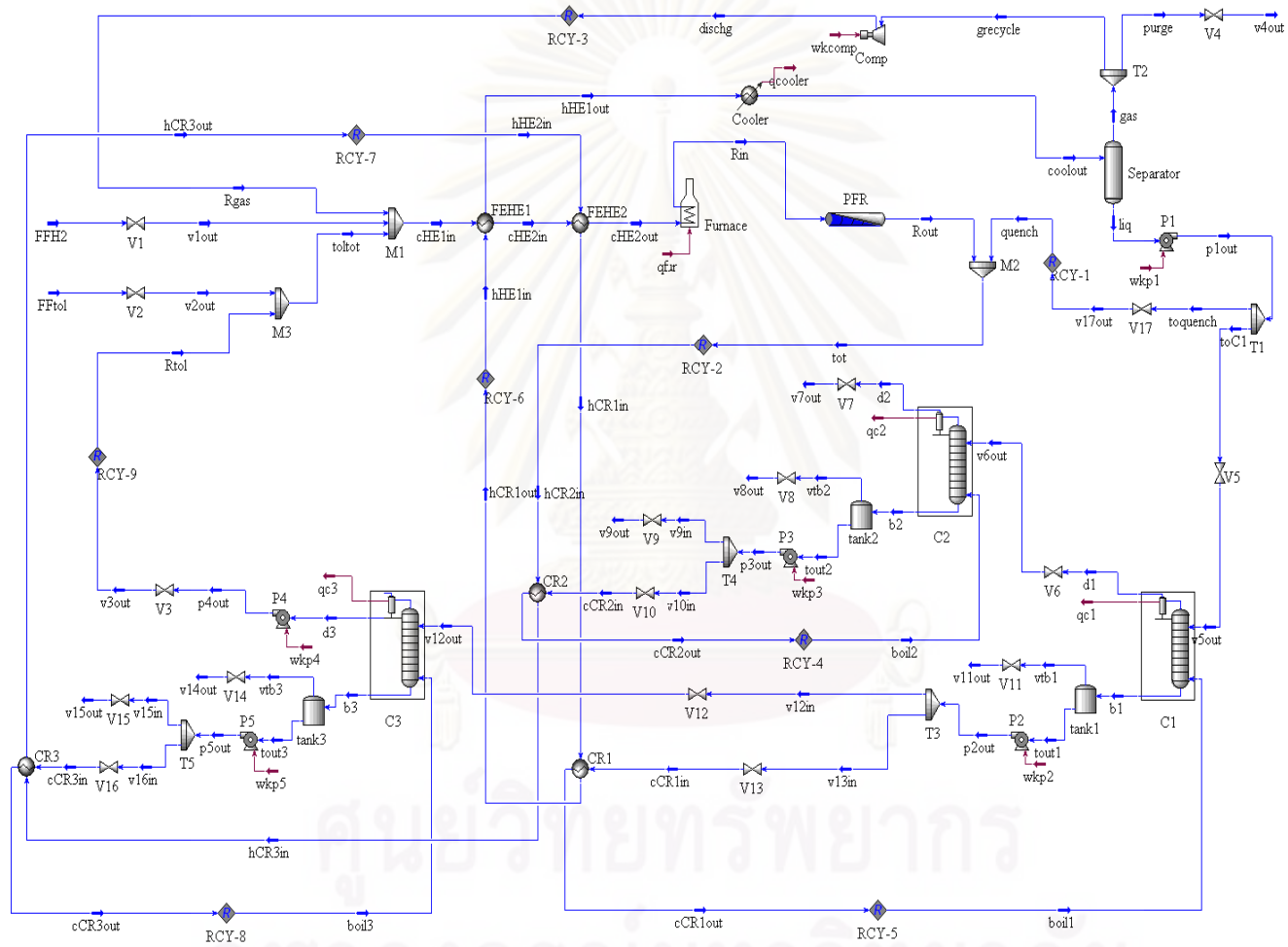

Figure 5.18 HYSYS flowsheet of the steady state model of the complex heat-integrated HDA plant HIP6.3

5.5 Energy Comparisons of Complex Heat-Integrated HDA Plant

From steady state simulations of the complex heat-integrated HDA plant HIP 5.1, 5.2, 6.1, 6.2 and 6.3, the energy savings that saved from the simply heat-integrated HDA plant HIP1 (Base case) are shown in Table 5.11.

Energy savings for heat-integrated structures compared with the typical HDA process show in Table 5.12. In Our work, the heat-integrated plant (HIP) of HDA process can save energy approximate 21 percent from the typical HDA process alternative1 (Base case). The energy savings of the complex heat-integrated HDA plant HIP5 and 6 are close to, as shown in Table 5.11 and 5.12.

Table 5.11 Energy savings of the heat-integrated HDA plant (Steady state simulation)

Heat-integrated plant (HIP) of HDA process	Alternatives					
	HIP 1 (BC)	HIP 5.1	HIP 5.2	HIP 6.1	HIP 6.2	HIP 6.3
Cooler	2197	1210	1211	1167	1168	1168
Stabilizer Column Condenser	2635.3	2657.9	2652.9	2650.5	2653.5	2652.2
Product Column Condenser	1089.3	1094.6	1094	1094.5	1095.7	1094.6
Recycle Column Condenser	417.9	427.4	429.64	430.1	428.9	429.5
Total Cold Utilities Usage, kW	6339.5	5389.9	5387.54	5342.1	5346.1	5344.3
Furnace	383.6	4248	4241	4362	4366	4365
Stabilizer Column Reboiler	4448.3	0	0	0	0	0
Product Column Reboiler	174.3	177.7	177.7	0	0	0
Recycle Column Reboiler	316	0	0	0	0	0
Total Hot Utilities Usage, kW	5322.2	4425.7	4418.7	4362	4366	4365
Total Cold & Hot Utilities, kW	11661.7	9815.6	9806.24	9704.1	9712.1	9709.3
Energy Saving %	0.00	15.83	15.91	16.79	16.72	16.74

Table 5.12 Energy savings of the heat-integrated plant of HDA process compared with the typical HDA process (Steady State Simulation)

Description	Alternatives							
	AL 1 (BC)	HIP5.0	HIP 5.1	HIP 5.2	HIP6.0	HIP 6.1	HIP 6.2	HIP 6.3
Cooler	2197	1150	1210	1211	1152	1167	1168	1168
Stabilizer Column Condenser	174.3	386.5	2657.9	2652.9	382.7	2650.5	2653.5	2652.2
Product Column Condenser	4023.4	3787.3	1094.6	1094	3810.6	1094.5	1095.7	1094.6
Recycle Column Condenser	430.4	0	427.4	429.64	0	430.1	428.9	429.5
Total Cold Utilities Usage, kW	6825.1	5323.8	5389.9	5387.54	5345.3	5342.1	5346.1	5344.3
Furnace	383.6	3534	4248	4241	4135	4362	4366	4365
Stabilizer Column Reboiler	1260.4	0	0	0	0	0	0	0
Product Column Reboiler	3429.3	0	177.7	177.7	0	0	0	0
Recycle Column Reboiler	474.3	584.2	0	0	0	0	0	0
Heater Product Reboiler	0	0	0	0	0	0	0	0
Total Hot Utilities Usage, kW	5547.6	4118.2	4425.7	4418.7	4135	4362	4366	4365
Total Cold & Hot Utilities, kW	12372.7	9442	9815.6	9806.24	9480.3	9704.1	9712.1	9709.3
Energy Saving %	0	23.69	20.67	20.74	23.38	21.57	21.50	21.53

CHAPTER VI

CONTROL STRUCTURES DESIGN AND DYNAMIC SIMULATION

The essential tasks of plantwide control for the complex plant which consist of recycle streams and energy integration is the plant energy and mass balances. When the operating condition changes, the control system is needed to reject disturbance loads and regulate an entire process into a design condition to achieve its objectives. Therefore, our purpose of this chapter is to present the new control structures of energy integrated process. Moreover, the three new designed control structures are also compared between typical and heat-integrated plant (HIP) of HDA process based on rigorous dynamic simulation by using the commercial software HYSYS.

6.1 Plantwide Control Strategies

The plantwide control structures in the typical and heat-integrated plant (HIP) of HDA process are designed based on the following heuristic design procedures are given by Luyben et al. (1999).

Step1. Establish Control Objectives

For this process, the essential is to produce pure benzene while minimizing yield losses of hydrogen and diphenyl. The reactor feed ratio of hydrogen to aromatics must be greater than 5:1. The reactor effluent gas must be quenched to 1150°F

Step2. Determine Control Degrees of Freedom

There are 23 control degrees of freedom. They include; two fresh feed valves for hydrogen and toluene, purge valve, separator base and overhead valves, cooler cooling water valve, liquid quench valve, furnace fuel valve, stabilizer column steam, bottoms, reflux, cooling water, and vapor product valves; product column steam,

bottoms, reflux, distillate, and cooling water valves; and recycle column steam, bottoms, reflux, distillate, and cooling water valves.

Step3. Establish Energy management system

The product benzene is produced from the exothermic reaction between hydrogen and toluene at 1158°F. The reactor operates adiabatically, so for a given reactor design the exit temperature depends upon the heat capacities of the reactor gases, reactor inlet temperature, and reactor conversion. Heat from the adiabatic reactor is carried in the effluent stream and is not removed from the process until it is dissipated to utility in the separator cooler.

Energy management of reaction section is handled by controlling the inlet and exit streams temperature of the reactor for preventing the benzene yield decreases from the side reaction. In the reference control structure, quenched stream is used for control temperature at the design value and for saving cost from the cooling utility. However, this method makes the path of disturbance propagation to the separation section, so the product purity control must be tighter because of component inventories changing. The alternative way is using of the heuristic laws; Montree (2000) introduces about the energy management that “Decreasing the effect of heat integration in the process can be done by remove the energy as much as possible”. Therefore, the cooling utility should be used for controlling the reactor exit temperature and preventing the disturbance propagation to the separation section as the second control structure. Another energy control loop is using of the cooling utility for removing excess heat from the heat exchanger to reach the optimal temperature in the separator.

Step4. Set Production Rate

There are not constrained to set production either by supply or demand, then the production rate can be set by benzene production. Considering of the kinetics equation is found that the three variables alter the reaction rate; pressure, temperature and toluene concentration which is the limiting agent.

- Pressure control of the compressor operates at maximum capacity for yield purpose.

- Reactor inlet temperature is controlled by specify the reactant fresh feed rate and reactant composition into the reactor. The reactor inlet temperature is constrained below 1300°F for preventing the cracking reaction that produces undesired byproduct.
- Toluene inventory can be controlled in liquid level at the top of recycle column is measured to change toluene feed flow.

Step5. Control Product Quality, Handle Safety, Operational, and Environmental Constraints

Constraints Benzene purity must be maintained at 99.97 percent for this research. Any methane that leaves in the bottoms of the stabilizer column contaminates the benzene product. The separation in the stabilizer column prevents the problem by using a temperature to set column steam rate (boil up). Toluene in the overhead of the product column also affects benzene quality. Benzene purity can be controlled by manipulating the column steam rate (boil up) to maintain temperature in the column.

Step6. Control Inventories (Pressure and Liquid Level) and Fix a Flow in Every Recycle Loop

In most processes a flow control should be present in all recycle loops. This is a simple and effective way to prevent potentially large changes in recycle flows, while the process is perturbed by small disturbance. We call this high sensitivity of the recycle flowrates to small disturbances the “snowball effect”. There are two recycle control loops.

Four pressures and seven liquid levels must be controlled in this process. For the pressures, there are in the gas loop and in the three distillation columns. In the gas loop, the separator overhead valve is opened and run the compressor at maximum gas recycle rate to improve yield so the gas loop control is related to the purge stream and fresh hydrogen feed flow. In the stabilizer column, vapor product flow is used to control pressure. In the product and recycle columns, pressure control can be achieved by manipulating cooling water flow to regulate overhead condensation rate.

For liquid loops, there are a separator and two (base and overhead receiver) in each column. The most direct way to control separator level is with the liquid flow to the stabilizer column. The stabilizer column overhead level is controlled with cooling water flow and base level is controlled with bottoms flow. In the product column, distillate flow controls overhead receiver level and bottoms flow controls base level. In the recycle column, control structure use the fresh toluene feed flow to control level. The base level of recycle column is controlled by manipulating the column steam flow because it has much larger effect than bottoms flow.

Step7. Check Component Balances

Component balances control loops consists of:

- Methane is purged from the gas recycle loop to prevent it from accumulating and its composition can be controlled with the purge flow.
- Diphenyl is removed in the bottoms stream from the recycle column, where steam flow controls base level.
- The inventory of benzene is accounted for by temperature and overhead receiver level control in the product column.
- Toluene inventory is accounted for by level control in the recycle column overhead receiver.
- Gas loop pressure control accounts for hydrogen inventory.

Step8. Control Individual Unit Operations

The rest degrees of freedom are assigned for control loops within individual units. These include:

- Cooling water flow to the cooler controls process temperature to the separator.
- Refluxes to the stabilizer, product, and recycle columns are flow controlled.

Step9. Optimize Economic and Improve Dynamic Controllability

The basic regulatory strategy has now been established. Some freedom is used to select several controller set points to optimize economics and plant performance. Such as, the set point for the methane composition controller in the gas recycle loop must balance the trade-off between yield loss and reactor performance. Reflux flows to the stabilizer, product, and recycle columns must be determined based upon column

energy requirement and potential yield losses of benzene (in the overhead of the stabilizer and recycle columns) and toluene (in the base of the recycle column).

6.2 Energy Management of Heat-Integrated Process

As the operating conditions change, the designed control system must regulate the entire process to meet the desired condition. On the other hand, changes in the heat load disturbance of the cold or hot stream affect energy consumption of its utility units. Therefore, for a complex energy-integrated plant, it is important to study the heat pathway control in order to manage the heat load disturbance in such a way that the maximum energy recovery (MER) can always be achieved.

The heat pathway heuristics (HPH) is used in design and operation of resilient heat exchanger network (RHEN). HPH is about how to properly direct heat load disturbance throughout the network to heat sinks (coolers) or heat sources (heaters) in order to achieve MER at all time. Two kinds of disturbances are needed to be introduced:

- Positive disturbance load (D+) is a disturbance that will increase the heat load of a stream. The disturbance heat load must be dissipated as much as possible by transferring or shifting it to the streams that are serviced by utility exchangers. The positive disturbance load of a hot stream will increase heat duties of coolers and decrease heat duties of heaters. The positive disturbance load of a cold stream will increase heat duties of heaters and decrease heat duties of coolers.
- Negative disturbance load (D-) is the disturbance that will make the heat load of a stream decrease. The negative disturbance load of a hot stream will increase the heat duties of heaters or decrease the heat duties of coolers. The negative disturbance load of a cold stream will increase the heat duties of coolers or decrease the heat duties of heaters.

There are two cases to be considered to shift the heat load disturbance to heat sinks (coolers) or heat sources (heaters):

- Shifted to a utility exchanger within its subnetwork (heating or cooling subnetwork). To maintain maximum energy recovery (MER), the heat load

must be shifted within the subnetwork of the disturbance origin to utility exchangers.

- Shifted to a utility exchanger across its subnetwork. The amount of heat load that cannot be distributed within its subnetwork can be shifted to utility exchangers across the pinch temperature.

We look at the plantwide control issues around energy management. The control configurations of resilient heat exchanger network are determined using the heat pathway heuristics, HPH (Wongsri and Hermawan, 2005). The objective of HPH design is to find proper heat pathways to achieve the dynamic heat exchanger network operation objective which is desired target variables and maximum energy recovery. As the operating conditions change or heat load disturbances enter, the designed control system must regulate the heat flow within the network to meet the desired goal.

6.2.1 Heat Pathways and Heat Exchanger Network Control Configuration for Complex Heat-Integrated of the typical HDA Process Alternative 5

The heat pathways of the typical HDA process alternative 5 are shown in Figure 6.1. The positive and negative disturbance loads of H1 and H2 are shifted to furnace. Thus, the positive disturbance load of hot streams will decrease the furnace duty which is good. The negative disturbance load of hot streams will increase the furnace duty which is ruled by ΔT_{\min} constraint. The positive and negative disturbance loads of C1 and C2 cold streams are shifted to cooler, but the disturbance loads of C3 are shifted to furnace. Thus, the positive disturbance load of C1 and C2 cold streams will decrease the cooler duty which is good. The negative disturbance load of C1 and C2 cold streams will increase the cooler duty which is ruled by ΔT_{\min} constraint. For C3, the positive and negative disturbance loads will increase and decrease furnace duty, respectively.

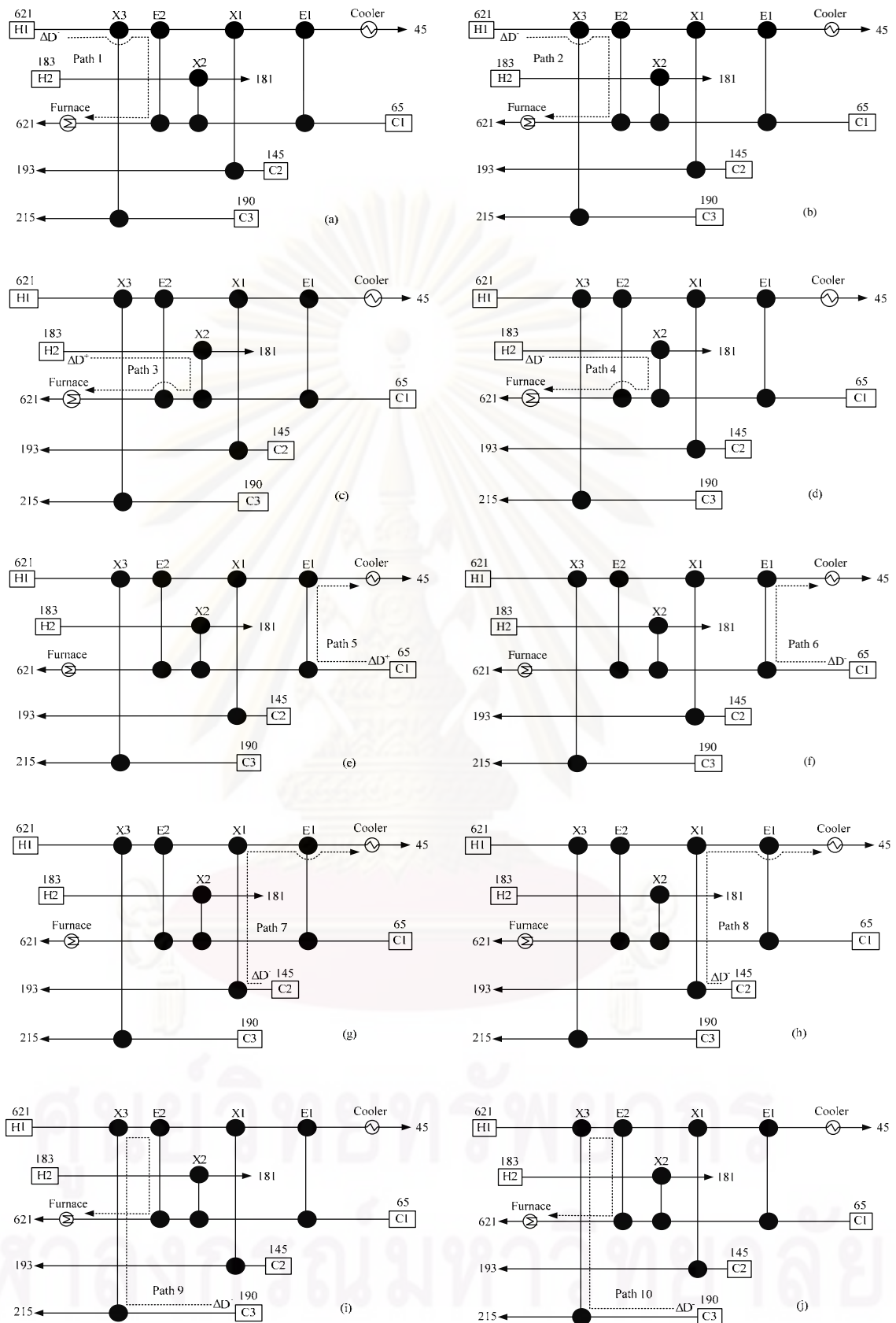

Figure 6.1 Heat pathways of the typical HDA process alternative 5 (HIP5.0), where: (a) path 1 is used to shift the positive disturbance load of the H1 hot stream to the

furnace, (b) path 2 is used to shift the negative disturbance load of the H1 hot stream to the furnace, (c) path 3 is used to shift the positive disturbance load of the H2 hot stream to the furnace, (d) path 4 is used to shift the negative disturbance load of the H2 hot stream to the furnace, (e) path 5 is used to shift the positive disturbance load of the C1 cold stream to the cooler, (f) path 6 is used to shift the negative disturbance load of the C1 cold stream to the cooler, (g) path 7 is used to shift the positive disturbance load of the C2 cold stream to the cooler, (h) path 8 is used to shift the negative disturbance load of the C2 cold stream to the cooler, (i) path 9 is used to shift the positive disturbance load of the C3 cold stream to the furnace and (j) path 10 is used to shift the negative disturbance load of the C3 cold stream to the furnace

From the heat pathways of the typical HDA process alternative 5, we can design the control configurations as show in Figure 6.2.

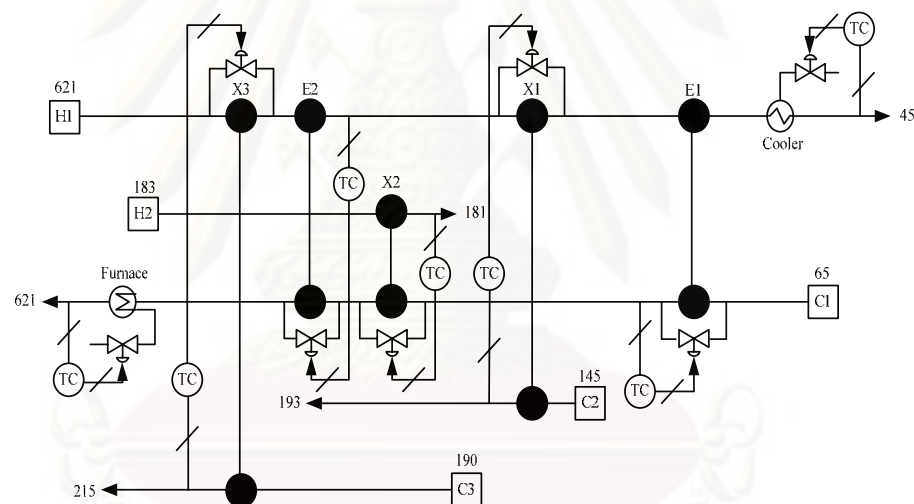
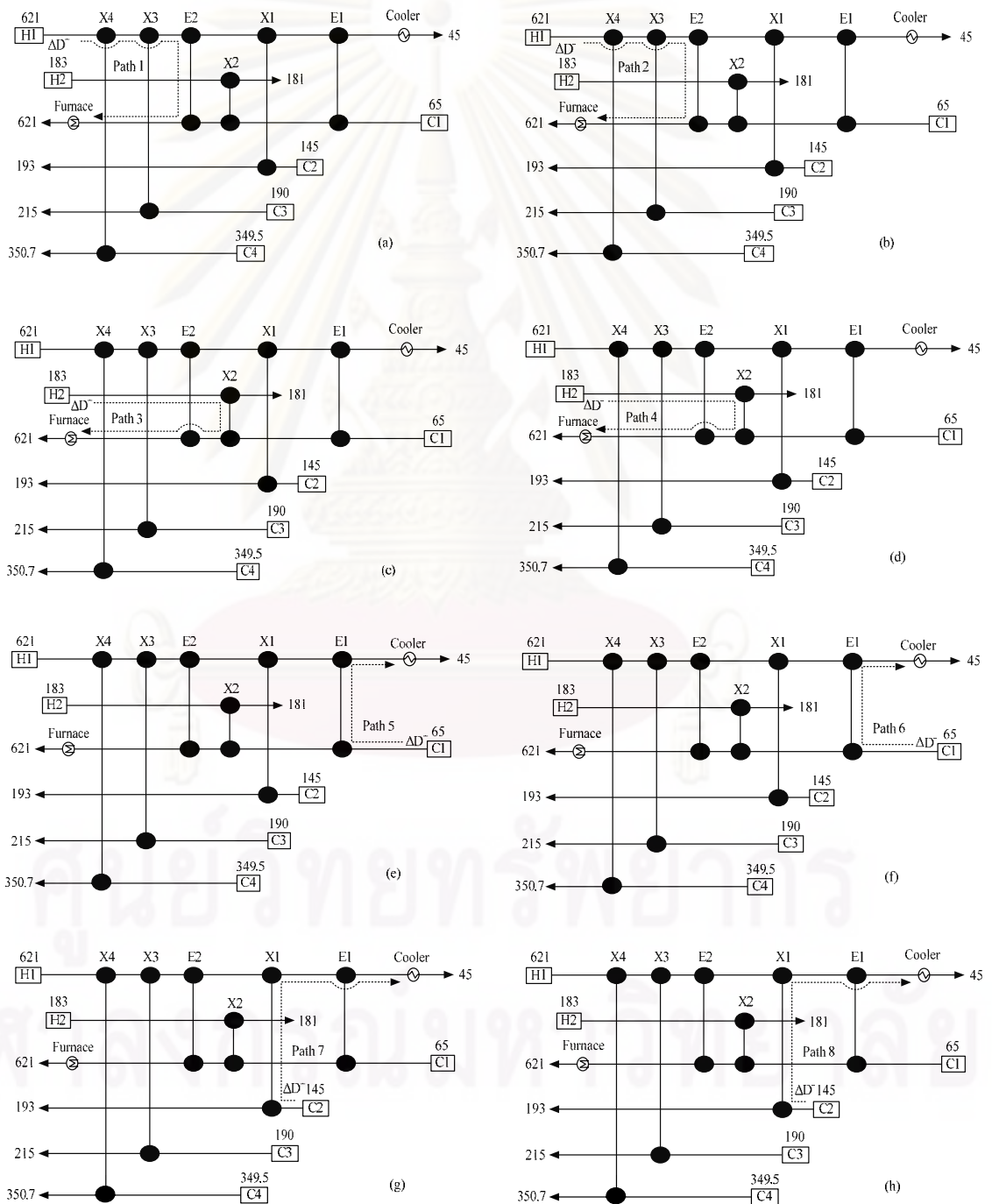

Figure 6.2 Control configurations of alternative 5 (HIP5.0)

6.2.2 Heat Pathways and Heat Exchanger Network Control Configuration for Complex Heat-Integrated of the typical HDA Process Alternative 6

The heat pathways of the typical HDA process alternative 6 are shown in Figure 6.3. The positive and negative disturbance loads of H1 and H2 are shifted to furnace. Thus, the positive disturbance load of hot streams will decrease the furnace duty which is good. The negative disturbance load of hot streams will increase the furnace duty which is ruled by ΔT_{\min} constraint. The positive and negative disturbance loads of C1 and C2 cold streams are shifted to cooler. Thus, the positive disturbance

load of C1 and C2 cold streams will decrease the cooler duty which is good. The negative disturbance load of C1 and C2 cold streams will increase the cooler duty which is ruled by ΔT_{\min} constraint. The positive and negative disturbance loads of C3 and C4 cold streams are shifted to furnace. Thus, the negative disturbance load of C3 and C4 cold streams will decrease the furnace duty which is good. The positive disturbance load of C3 and C4 cold streams will increase the furnace duty which is ruled by ΔT_{\min} constraint.



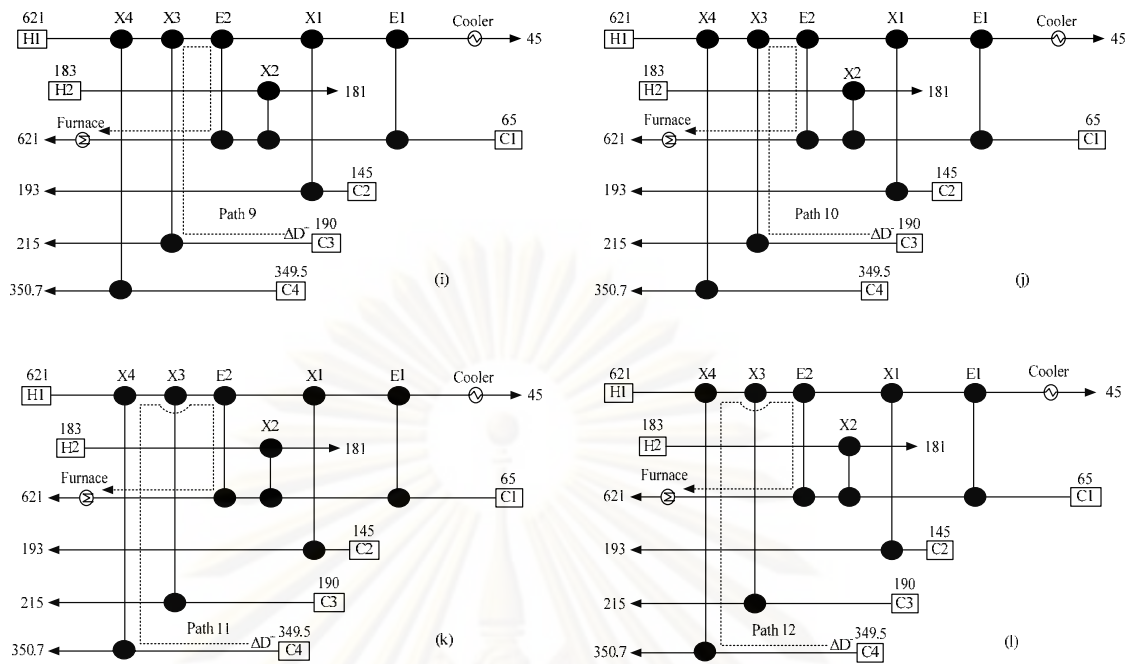

Figure 6.3 Heat pathways of the typical HDA process alternative 6 (HIP6.0), where: (a) path 1 is used to shift the positive disturbance load of the H1 hot stream to the furnace, (b) path 2 is used to shift the negative disturbance load of the H1 hot stream to the furnace, (c) path 3 is used to shift the positive disturbance load of the H2 hot stream to the furnace, (d) path 4 is used to shift the negative disturbance load of the H2 hot stream to the furnace, (e) path 5 is used to shift the positive disturbance load of the C1 cold stream to the cooler, (f) path 6 is used to shift the negative disturbance load of the C1 cold stream to the cooler, (g) path 7 is used to shift the positive disturbance load of the C2 cold stream to the cooler, (h) path 8 is used to shift the negative disturbance load of the C2 cold stream to the cooler, (i) path 9 is used to shift the positive disturbance load of the C3 cold stream to the furnace, (j) path 10 is used to shift the negative disturbance load of the C3 cold stream to the furnace, (k) path 11 is used to shift the positive disturbance load of the C4 cold stream to the furnace and (l) path 12 is used to shift the negative disturbance load of the C4 cold stream to the furnace

From the heat pathways of the typical HDA process alternative 6, we can design the control configurations as show in Figure 6.4.

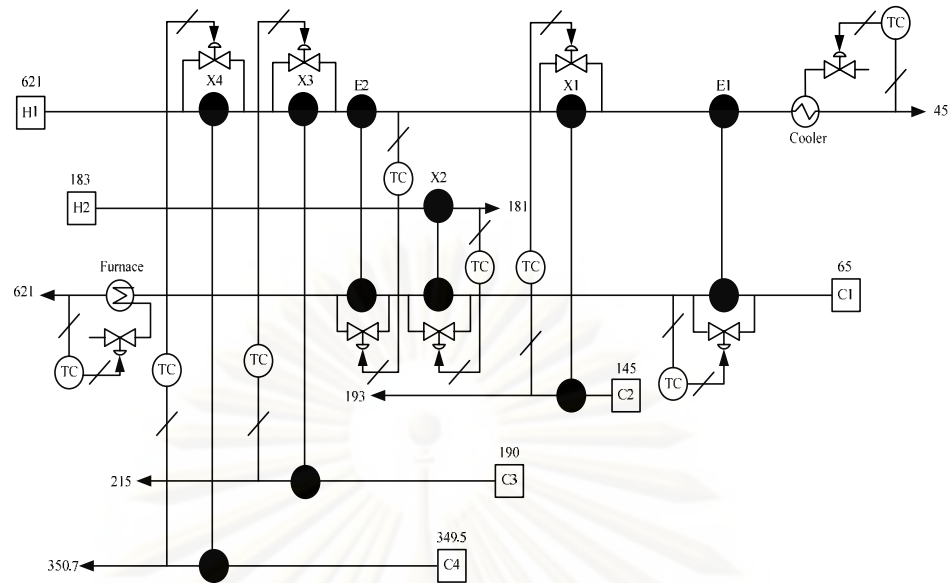

Figure 6.4 Control configurations of alternative 6 (HIP6.0)

6.2.3 Heat Pathways and Heat Exchanger Network Control Configuration for Complex Heat-Integrated HDA Plant HIP5

The two resilient heat exchanger networks of HIP5 are represented by HIP5.1 and HIP5.2. Therefore, the heat pathways of HIP5 are consists of heat pathways of HIP5.1 and HIP5.2.

6.2.3.1 Heat Pathways and Heat Exchanger Network Control configuration for Complex Heat-Integrated HDA Plant HIP5.1

The heat pathways of HIP5.1 are shown in Figure 6.5. The positive and negative disturbance loads of H1 are shifted to furnace. Thus, the positive disturbance load of hot streams will decrease the furnace duty which is good. The negative disturbance load of hot streams will increase the furnace duty which is ruled by ΔT_{\min} constraint. The positive and negative disturbance loads of C1 and C2 cold streams are shifted to cooler, but the disturbance loads of C3 are shifted to furnace. Thus, the positive disturbance load of C1 and C2 cold streams will decrease the cooler duty which is good. The negative disturbance load of C1 and C2 cold streams will increase the cooler duty which is ruled by ΔT_{\min} constraint. For C3, the positive and negative disturbance loads will increase and decrease furnace duty, respectively.

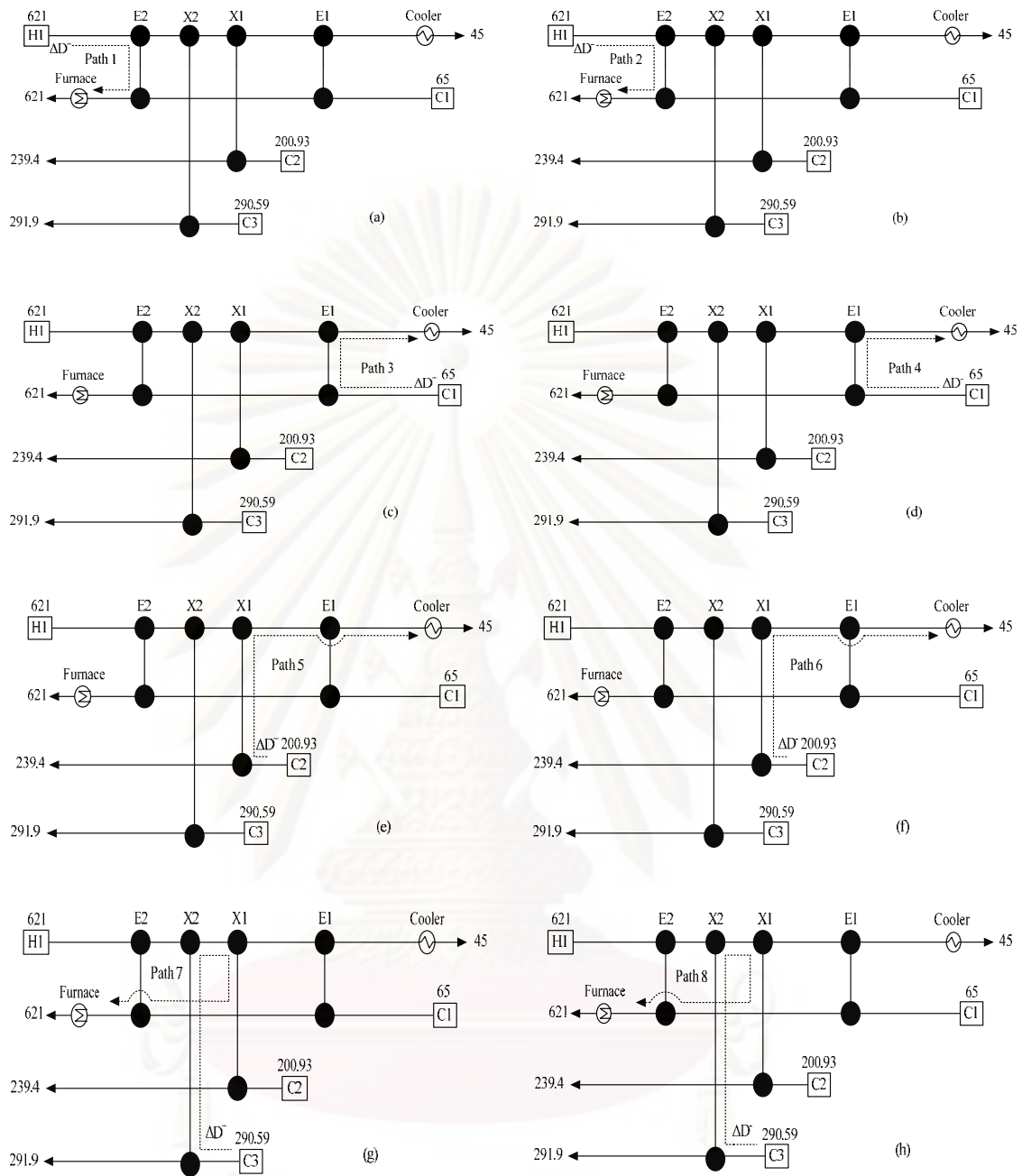

Figure 6.5 Heat pathways of HIP5.1, where: (a) path 1 is used to shift the positive disturbance load of the H1 hot stream to the furnace, (b) path 2 is used to shift the negative disturbance load of the H1 hot stream to the furnace, (c) path 3 is used to shift the positive disturbance load of the C1 cold stream to the cooler, (d) path 4 is used to shift the negative disturbance load of the C1 cold stream to the cooler, (e) path 5 is used to shift the positive disturbance load of the C2 cold stream to the cooler, (f) path 6 is used to shift the negative disturbance load of the C2 cold stream to the cooler, (g) path 7 is used to shift the positive disturbance load of the C3 cold stream to

the furnace and (h) path 8 is used to shift the negative disturbance load of the C3 cold stream to the furnace

From the heat pathways of HIP5.1, we can design the control configurations as show in Figure 6.6.

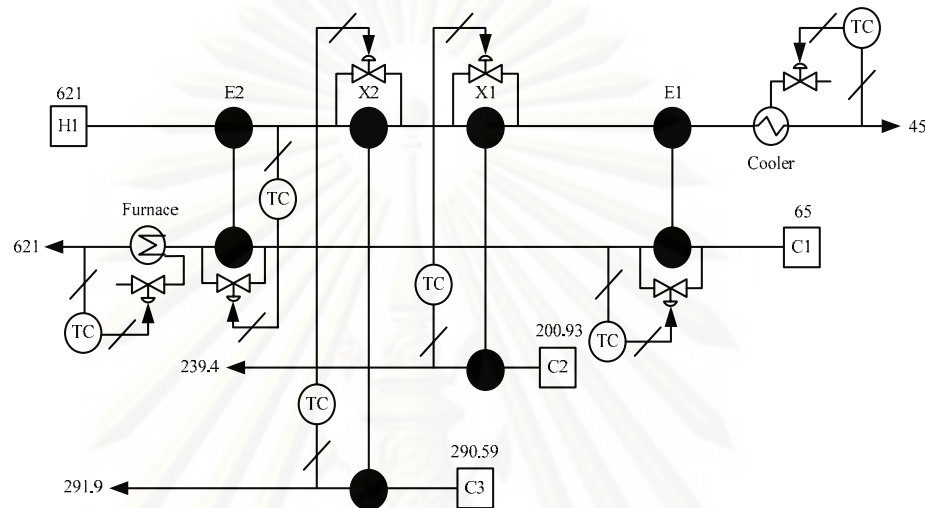

Figure 6.6 Control configurations of HIP5.1

6.2.3.2 Heat Pathways and Heat Exchanger Network Control configuration for Complex Heat-Integrated HDA Plant HIP5.2

The heat pathways of HIP5.2 are shown in Figure 6.7. The positive and negative disturbance loads of H1 are shifted to furnace. Thus, the positive disturbance load of hot streams will decrease the furnace duty which is good. The negative disturbance load of hot streams will increase the furnace duty which is ruled by ΔT_{\min} constraint. The positive and negative disturbance loads of C1 and C2 cold streams are shifted to cooler, but the disturbance loads of C3 are shifted to furnace. Thus, the positive disturbance load of C1 and C2 cold streams will decrease the cooler duty which is good. The negative disturbance load of C1 and C2 cold streams will increase the cooler duty which is ruled by ΔT_{\min} constraint. For C3, the positive and negative disturbance loads will increase and decrease furnace duty, respectively.

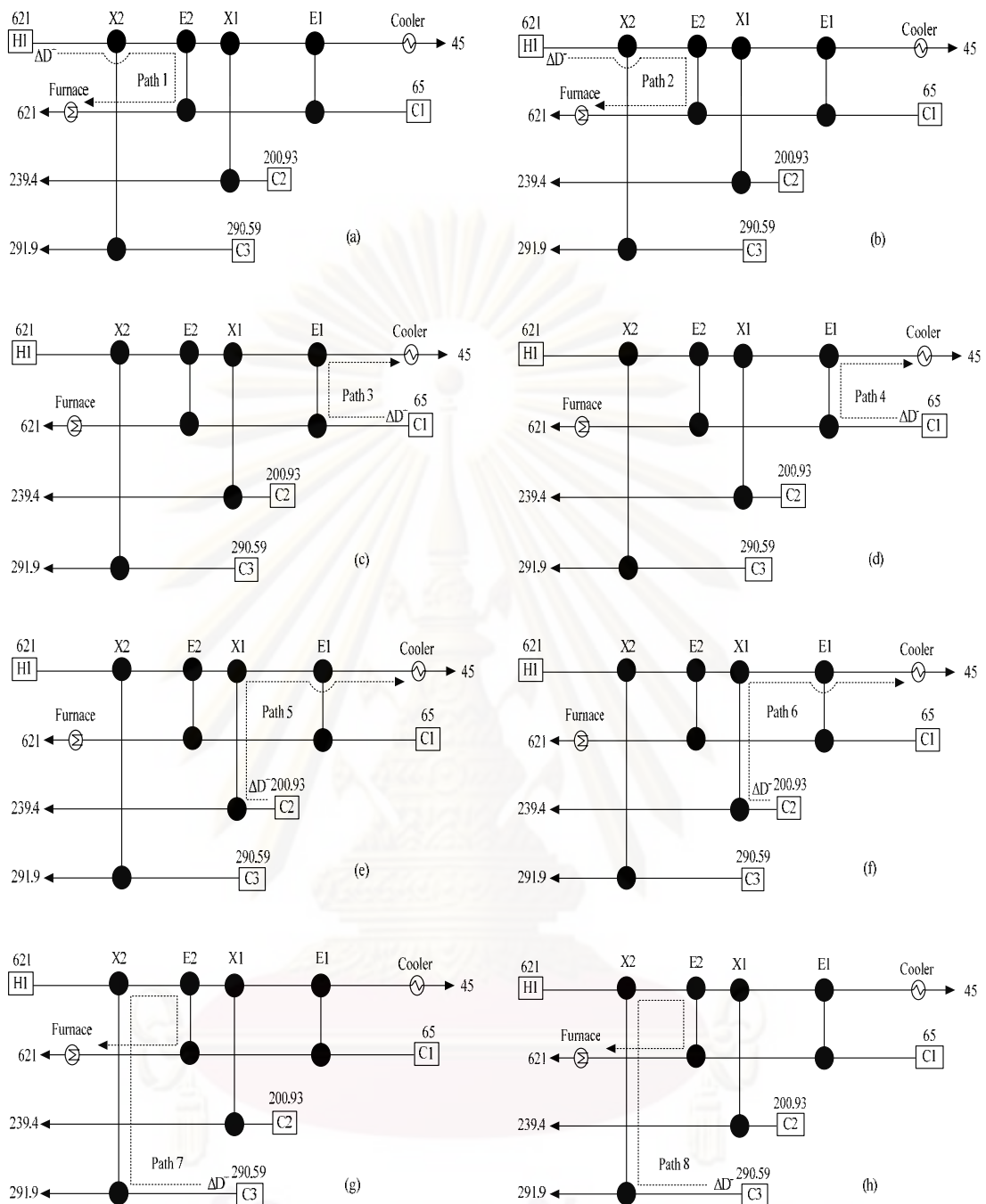

Figure 6.7 Heat pathways of HIP5.2, where: (a) path 1 is used to shift the positive disturbance load of the H1 hot stream to the furnace, (b) path 2 is used to shift the negative disturbance load of the H1 hot stream to the furnace, (c) path 3 is used to shift the positive disturbance load of the C1 cold stream to the cooler, (d) path 4 is used to shift the negative disturbance load of the C1 cold stream to the cooler, (e) path 5 is used to shift the positive disturbance load of the C2 cold stream to the cooler, (f) path 6 is used to shift the negative disturbance load of the C2 cold stream to the cooler, (g) path 7 is used to shift the positive disturbance load of the C3 cold stream to

the furnace and (h) path 8 is used to shift the negative disturbance load of the C3 cold stream to the furnace

From the heat pathways of HIP5.2, we can design the control configurations as show in Figure 6.8.

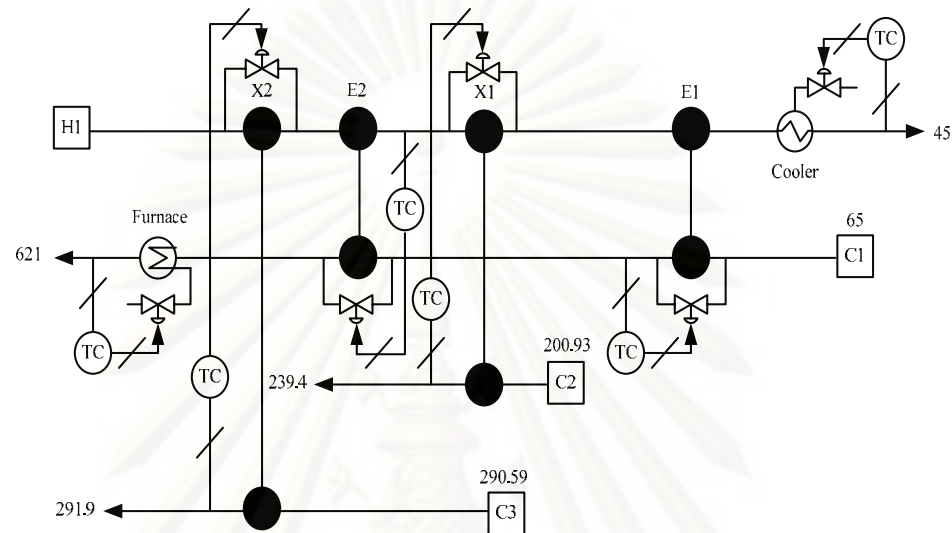

Figure 6.8 Control configurations of HIP5.2

6.2.4 Heat Pathways and Heat Exchanger Network Control Configuration for Complex Heat-Integrated HDA Plant HIP6

The three resilient heat exchanger networks of HIP6 are represented by HIP6.1, HIP6.2 and HIP6.3. Therefore, the heat pathways of HIP6 are consists of heat pathways of HIP6.1, HIP6.2 and HIP6.3.

6.2.4.1 Heat Pathways and Heat Exchanger Network Control Configuration for Complex Heat-Integrated HDA Plant HIP6.1

The heat pathways of HIP6.1 are shown in Figure 6.9. The positive and negative disturbance loads of H1 are shifted to furnace. Thus, the positive disturbance load of hot streams will decrease the furnace duty which is good. The negative disturbance load of hot streams will increase the furnace duty which is ruled by ΔT_{\min} constraint. The positive and negative disturbance loads of C1 and C4 cold streams are shifted to cooler. Thus, the positive disturbance load of C1 and C4 cold streams will decrease the cooler duty which is good. The negative disturbance load of C1 and C4

cold streams will increase the cooler duty which is ruled by ΔT_{\min} constraint. The positive and negative disturbance loads of C2 and C3 cold streams are shifted to furnace. Thus, the negative disturbance load of C2 and C3 cold streams will decrease the furnace duty which is good. The positive disturbance load of C2 and C3 cold streams will increase the furnace duty which is ruled by ΔT_{\min} constraint.

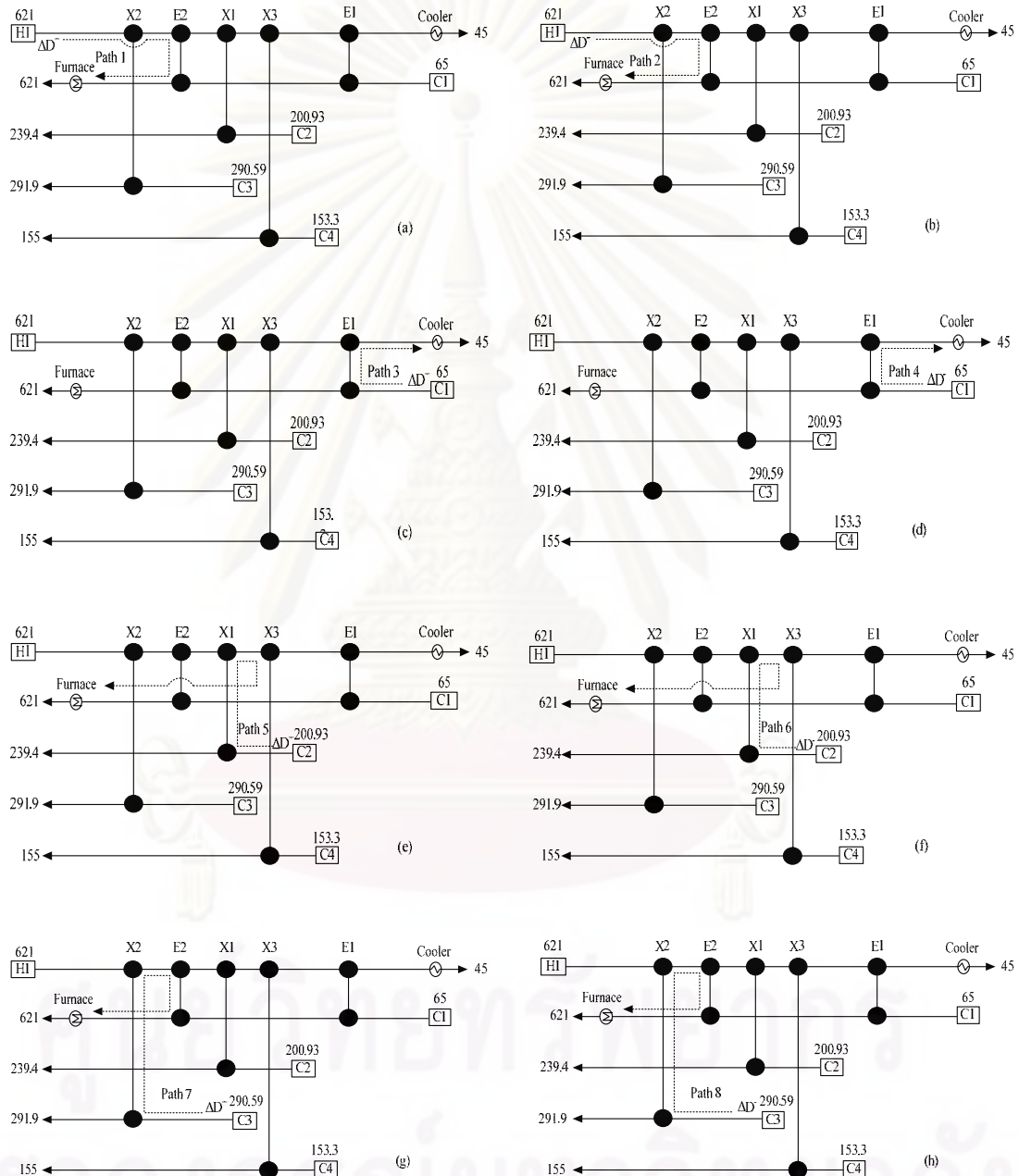

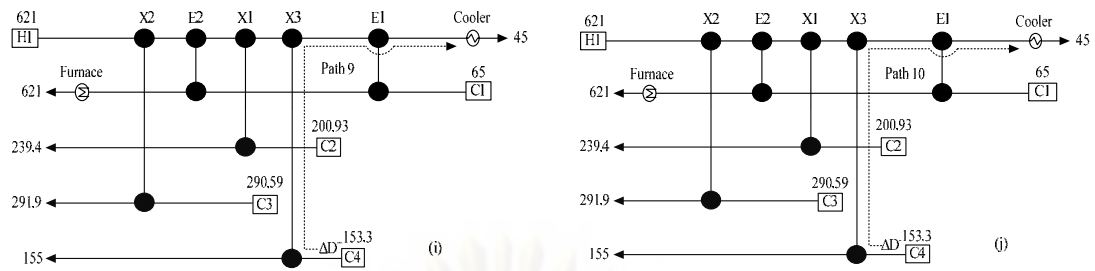

Figure 6.9 Heat pathways of HIP6.1, where: (a) path 1 is used to shift the positive disturbance load of the H1 hot stream to the furnace, (b) path 2 is used to shift the negative disturbance load of the H1 hot stream to the furnace, (c) path 3 is used to shift the positive disturbance load of the C1 cold stream to the cooler, (d) path 4 is used to shift the negative disturbance load of the C1 cold stream to the cooler, (e) path 5 is used to shift the positive disturbance load of the C2 cold stream to the furnace, (f) path 6 is used to shift the negative disturbance load of the C2 cold stream to the furnace, (g) path 7 is used to shift the positive disturbance load of the C3 cold stream to the furnace, (h) path 8 is used to shift the negative disturbance load of the C3 cold stream to the furnace, (i) path 9 is used to shift the positive disturbance load of the C4 cold stream to the cooler, (j) path 10 is used to shift the negative disturbance load of the C4 cold stream to the cooler

From the heat pathways of HIP6.1, we can design the control configurations as show in Figure 6.10.

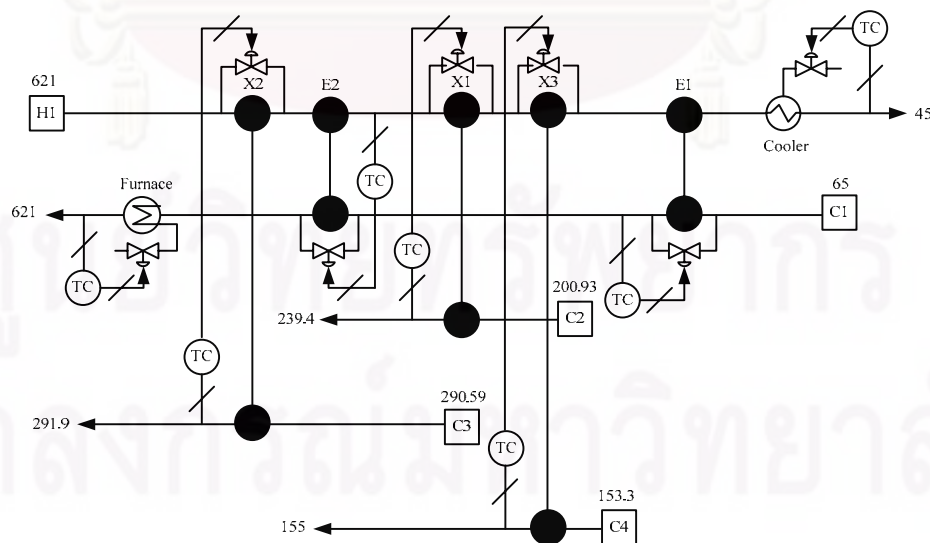
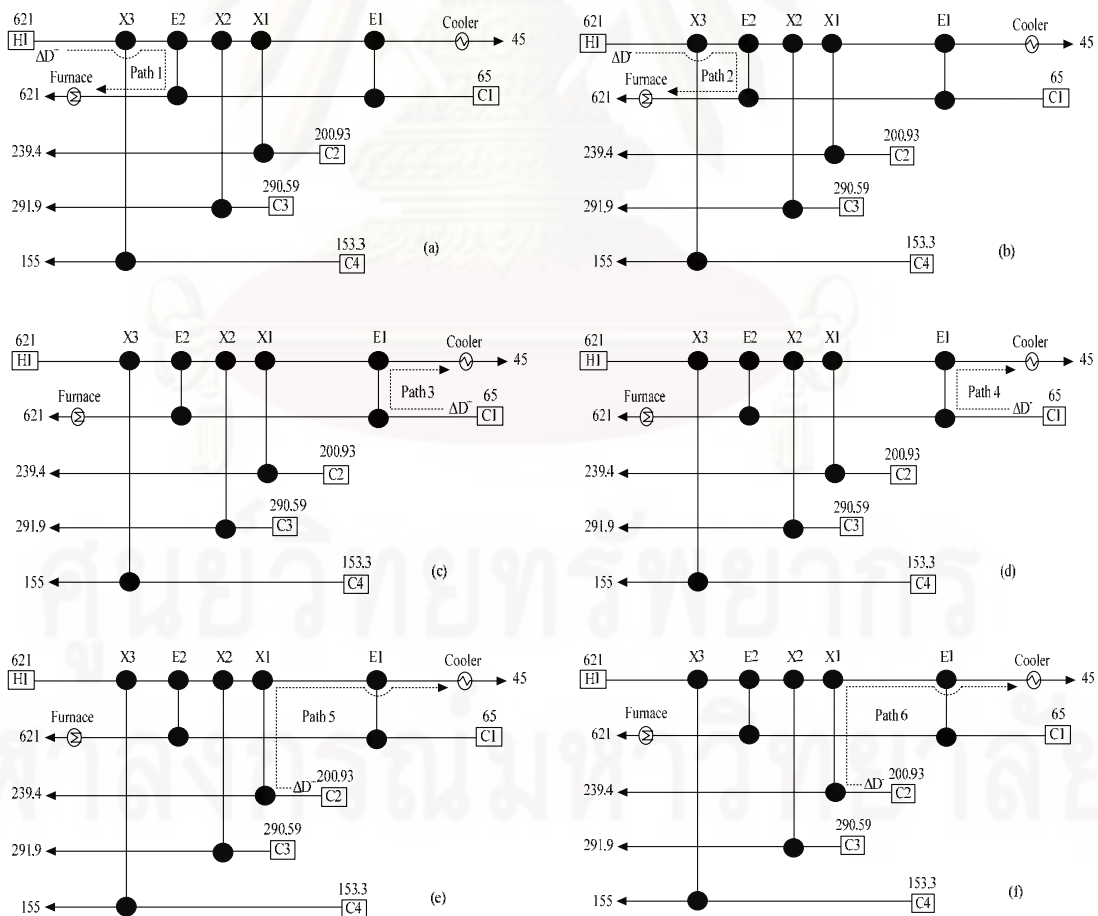

Figure 6.10 Control configurations of HIP6.1

6.2.4.2 Heat Pathways and Heat Exchanger Network Control Configuration for Complex Heat-Integrated HDA Plant HIP6.2

The heat pathways of HIP6.2 are shown in Figure 6.11. The positive and negative disturbance loads of H1 are shifted to furnace. Thus, the positive disturbance load of hot streams will decrease the furnace duty which is good. The negative disturbance load of hot streams will increase the furnace duty which is ruled by ΔT_{\min} constraint. The positive and negative disturbance loads of C1 and C2 cold streams are shifted to cooler. Thus, the positive disturbance load of C1 and C2 cold streams will decrease the cooler duty which is good. The negative disturbance load of C1 and C2 cold streams will increase the cooler duty which is ruled by ΔT_{\min} constraint. The positive and negative disturbance loads of C3 and C4 cold streams are shifted to furnace. Thus, the negative disturbance load of C3 and C4 cold streams will decrease the furnace duty which is good. The positive disturbance load of C3 and C4 cold streams will increase the furnace duty which is ruled by ΔT_{\min} constraint.



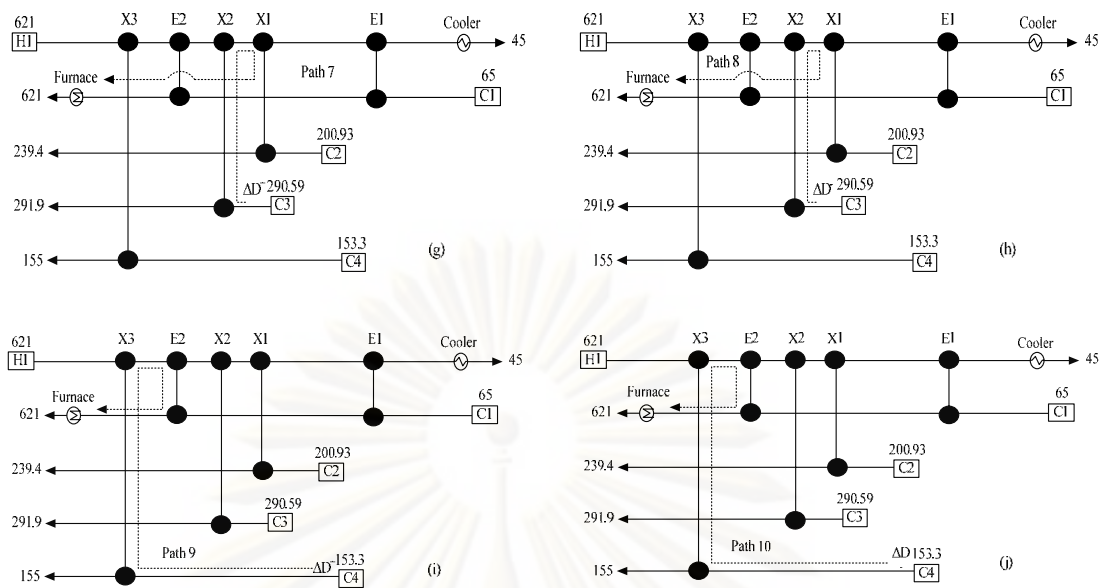

Figure 6.11 Heat pathways of HIP6.2, where: (a) path 1 is used to shift the positive disturbance load of the H1 hot stream to the furnace, (b) path 2 is used to shift the negative disturbance load of the H1 hot stream to the furnace, (c) path 3 is used to shift the positive disturbance load of the C1 cold stream to the cooler, (d) path 4 is used to shift the negative disturbance load of the C1 cold stream to the cooler, (e) path 5 is used to shift the positive disturbance load of the C2 cold stream to the cooler, (f) path 6 is used to shift the negative disturbance load of the C2 cold stream to the cooler, (g) path 7 is used to shift the positive disturbance load of the C3 cold stream to the furnace, (h) path 8 is used to shift the negative disturbance load of the C3 cold stream to the furnace, (i) path 9 is used to shift the positive disturbance load of the C4 cold stream to the furnace, (j) path 10 is used to shift the negative disturbance load of the C4 cold stream to the furnace

From the heat pathways of HIP6.2, we can design the control configurations as show in Figure 6.12.

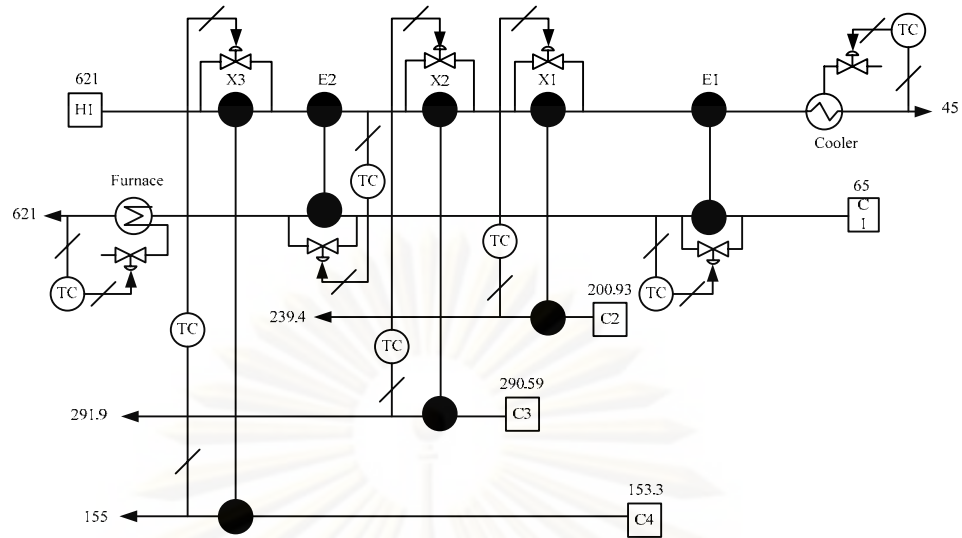
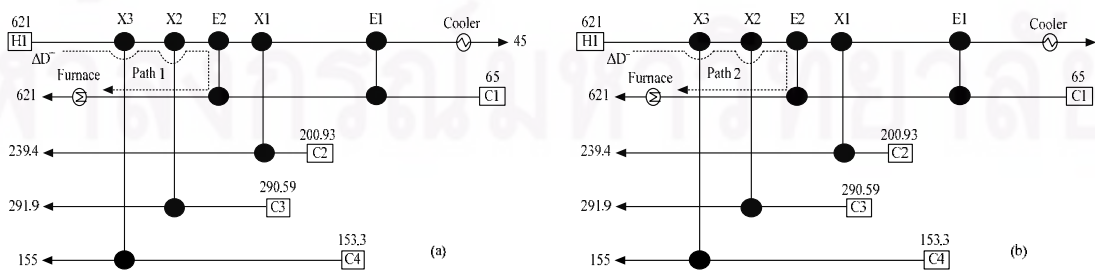

Figure 6.12 Control configurations of HIP6.2

6.2.4.3 Heat Pathways and Heat Exchanger Network Control Configuration for Complex Heat-Integrated HDA Plant HIP6.3

The heat pathways of HIP6.3 are shown in Figure 6.13. The positive and negative disturbance loads of H1 are shifted to furnace. Thus, the positive disturbance load of hot streams will decrease the furnace duty which is good. The negative disturbance load of hot streams will increase the furnace duty which is ruled by ΔT_{\min} constraint. The positive and negative disturbance loads of C1 and C2 cold streams are shifted to cooler. Thus, the positive disturbance load of C1 and C2 cold streams will decrease the cooler duty which is good. The negative disturbance load of C1 and C2 cold streams will increase the cooler duty which is ruled by ΔT_{\min} constraint. The positive and negative disturbance loads of C3 and C4 cold streams are shifted to furnace. Thus, the negative disturbance load of C3 and C4 cold streams will decrease the furnace duty which is good. The positive disturbance load of C3 and C4 cold streams will increase the furnace duty which is ruled by ΔT_{\min} constraint.



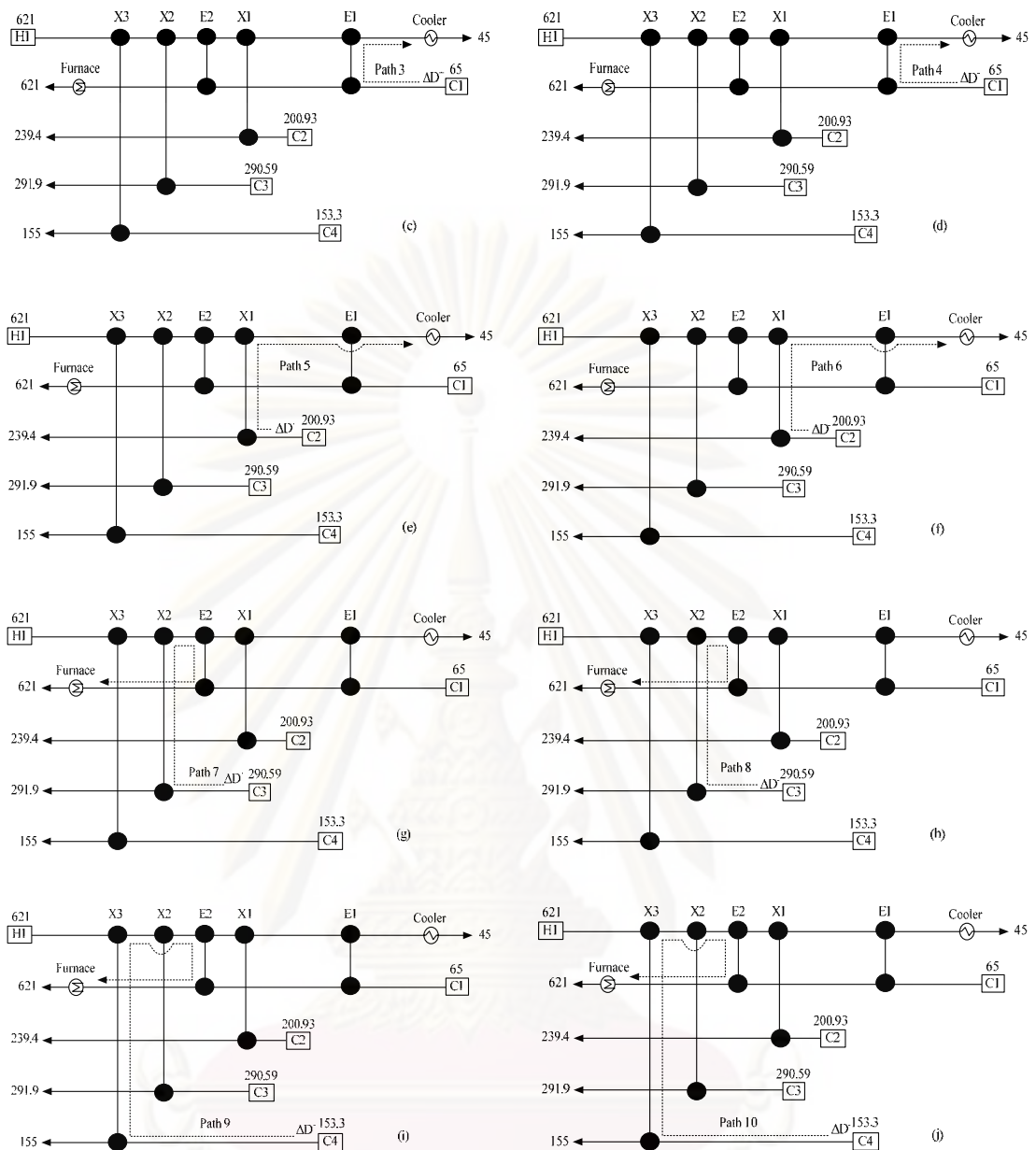

Figure 6.13 Heat pathways of HIP6.3, where: (a) path 1 is used to shift the positive disturbance load of the H1 hot stream to the furnace, (b) path 2 is used to shift the negative disturbance load of the H1 hot stream to the furnace, (c) path 3 is used to shift the positive disturbance load of the C1 cold stream to the cooler, (d) path 4 is used to shift the negative disturbance load of the C1 cold stream to the cooler, (e) path 5 is used to shift the positive disturbance load of the C2 cold stream to the cooler, (f) path 6 is used to shift the negative disturbance load of the C2 cold stream to the cooler, (g) path 7 is used to shift the positive disturbance load of the C3 cold stream to the furnace, (h) path 8 is used to shift the negative disturbance load of the C3 cold stream to the furnace, (i) path 9 is used to shift the positive disturbance load of the C4

cold stream to the furnace, (j) path 10 is used to shift the negative disturbance load of the C4 cold stream to the furnace

From the heat pathways of HIP6.3, we can design the control configurations as show in Figure 6.14.

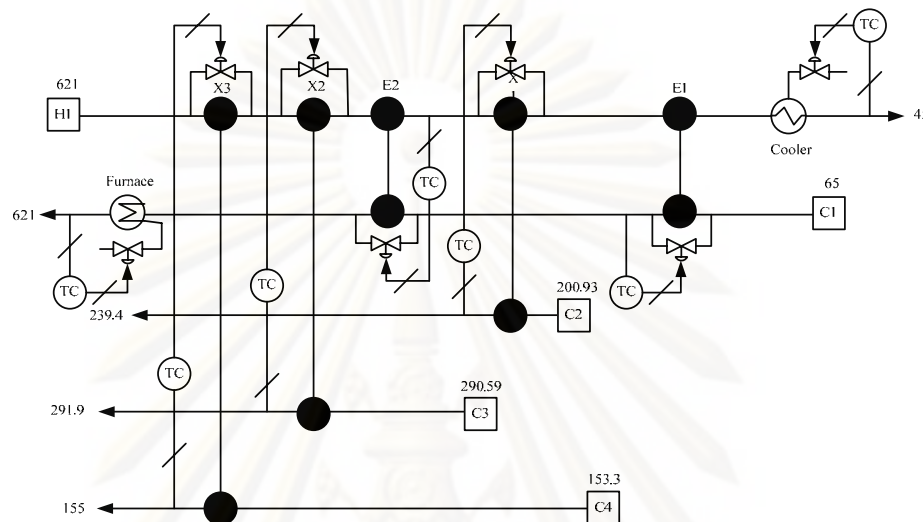

Figure 6.14 Control configurations of HIP6.3

6.3 Design of Plantwide Control Structure of HDA Process

In this work, the HDA process is designed by considering several control objectives (Luyben et al., 1999); they are: achieving a specified production rate of essential pure benzene (99.97 %-mole), achieving a ratio of hydrogen to aromatic greater than 5:1 in the reactor feed and quenching reactor effluent to a temperature of 621°C to prevent cooking and by-product formation in the heat exchanger.

The plantwide control structures in the heat-integrated processes are designed based on the heuristic design procedure given by Luyben et al. (1999). The major loops are the same as those used in Luyben et al. (1999), but we have designed two new loops for FEHE and three new loops for the three columns. In the literature (e.g. Luyben et al., 1999), a bypass control and an auxiliary utility exchanger are used for control in the heat integration system. In the current study is used only bypass control; the reason is that in our case the heat load of the heating stream is greater than the required heat load of reboiler.

For all the heat integration units, the bypass streams are designed to control the outlet temperatures of FEHEs and the tray temperatures in the three columns. The bypass stream should be about 5 to 10 percent of the total flow to be able to handle disturbances (Jones and Wilson, 1997). In normal operation, a control valve should operate with an opening between 20 to 80 percent (Jones and Wilson, 1997). In our study, the bypass valves in the process-to-process-heat-exchangers are designed with the valve opening of 50%, i.e. this translates into the bypass flow rates of about 6% of the total flow. In practice we have to overdesign the process-to-process-heat-exchanger, in order to be able to handle the disturbances. In this work, it is not our intention to study the best overdesign policy. The oversize of the heat exchanger is related to the estimated maximum size of disturbance loads of both the cold and hot streams. The size of disturbance in this study is about 5 to 10% according to Luyben's recommendations.

6.3.1 Plantwide Control Structures of Complex Heat-Integrated Typical HDA Process Alternative 5 (HIP5.0) and Alternative 6 (HIP6.0)

The three control structures are designed for the complex heat-integrated typical HDA process HIP5.0 and HIP6.0.

6.3.1.1 Control Structure 1 (CS1) of Complex Heat-Integrated Typical HDA Process HIP5.0

This control structure is shown in Figure 6.15 and the controller parameters are given in Table 6.1. This control structure, the all bypass of feed effluent heat exchangers (FEHE) are on cold side. The major loops in the typical HDA process are the same as those used in Luyben et al. (1999), the inlet temperature of furnace is controlled by manipulating the valve on the bypass line based on the heat pathway heuristics for plantwide control

Since the temperature profile in the recycle column is very sharp because of temperature changes from tray to tray. This means that the process gain is very large when a single tray temperature is controlled. The standard solution for this problem is to use an average (AVG) temperature of several trays instead of a single tray (Luyben, 2002). A heat exchanger (i.e. as a heat source or a heat sink) is artificially installed in the hot side stream (i.e. the exchanger X1 in Figure 6.15) in order to make the

disturbance loads of the hot stream (i.e. the hot reactor product). Note that, this exchanger is not used in the real plant, and the temperature controller TCX1 is set to be “off” whenever it is not used to make the disturbances.

The controller parameters are given in Table 6.1. P controllers are employed for level loops, PI controllers for the pressure and flow loops and PID controllers for temperature loops.

6.3.1.2 Control Structure 2 (CS2) of Complex Heat-Integrated Typical HDA

Process HIP5.0

The major loops in this control structure are the same as CS1 except for control loops of FEHE. The all bypass of FEHE are on hot side. This control structure is shown in Figure 6.16 and the controller parameters are given in Table 6.1.

6.3.1.3 Control Structure 3 (CS3) of Complex Heat-Integrated Typical HDA

Process HIP5.0

The major loops in this control structure are the same as CS1 except for temperature control in product distillation column. The temperature control in product distillation column is two point controls as the tray 12 and tray 17 temperature controls. This control structure is shown in Figure 6.17 and the controller parameters are given in Table 6.1.

Table 6.1 Controller parameters for the complex heat-integrated typical HDA process alternative 5 (HIP5.0): control structure 1, control structure 2 and control structure 3

Controller	Controlled variable	Manipulated variable	Type	Kc	Ti	Td
Reaction section						
PCG	gas recycle stream pressure	fresh feed hydrogen valve (V1)	PI	2	10	-
Fctol	total toluene flow rate	fresh feed toluene valve (V2)	PI	0.5	0.3	-
TCVBP1	FEHE1 cold outlet temperature	FEHE1 bypass cold stream valve (VBP1)	PID	12.3	0.221	0.049
TCVBP2	FEHE2 hot outlet temperature	FEHE2 bypass cold stream valve (VBP2)	PID	7.95	0.594	0.132
TCVBP1*	FEHE1 cold outlet temperature	FEHE1 bypass hot stream valve (VBP1)	PID	13.7	1.39	0.309
TCVBP2*	FEHE2 hot outlet temperature	FEHE2 bypass hot stream valve (VBP2)	PID	2.36	0.301	0.067
TCQ	quenched temperature	quench valve (V17)	PID	0.393	0.404	0.0898
TCR	reactor inlet temperature	furnace duty (qfur)	PID	0.259	0.416	0.0924
TCS	separator temperature	cooler duty (qcooler)	PID	2.45	0.298	0.0662
CCG	methane in gas recycle	purge valve (V4)	PI	0.5	15	-
LCS	separator liquid level	column C1 feed valve (V5)	P	2	-	-
Separation section : Stabilizer column						
PC1	column C1 pressure	column C1 gas valve (V6)	PI	2	10	-
TC1	column C1 tray-6 temperature	CR1 bypass valve (VBP3)	PI	2	10	-
LC11	column C1 base level	column C2 feed valve (V10)	P	2	-	-
LC12	column C1 reflux drum level	column C1 condenser duty (qc1)	P	2	-	-
FCB1	column C1 boil up flow rate	CR1 cold inlet valve (V9)	PI	0.5	0.3	-
Product column						
PC2	column C2 pressure	column C2 condenser duty (qc2)	PI	2	10	-
TC2	CR2 cold outlet temperature	CR2 bypass valve (VBP4)	PID	11.7	0.58	0.129
TC2-2	column C2 tray-12 temperature	auxiliary reboiler duty (Q-100)	PID	2.17	3.88	0.863
TC2-2-2**	column C2 tray-17 temperature	column C2 reflux flow rate	PID	1.58	38.4	8.54
LC21	column C2 base level	column C3 feed valve (V12)	P	2	-	-
LC22	column C2 reflux drum level	column C2 product valve level (V8)	P	2	-	-
FCB2	column C2 boil up flow rate	CR2 cold inlet valve (V13)	PI	0.5	0.3	-
Recycle column						
PC3	column C3 pressure	CR3 bypass valve (VBP11)	PI	2	10	-
TC3	AVG avg. temp. of C3 tray-1, 2, 3 and 4	column C3 by-product valve (V14)	PID	0.544	30.2	6.71
LC31	column C3 base level	column C3 reboiler duty (qr3)	P	2	-	-
LC32	column C3 reflux drum level	toluene recycle valve (V3)	P	2	-	-
FCR	column C3 reflux flow rate	reflux valve (V16)	PI	0.5	0.3	-

*TCVBP1 and 2 controllers are used in only control structure 2 (CS2).

**TC2-2-2 controller is used in only control structure 3 (CS3).

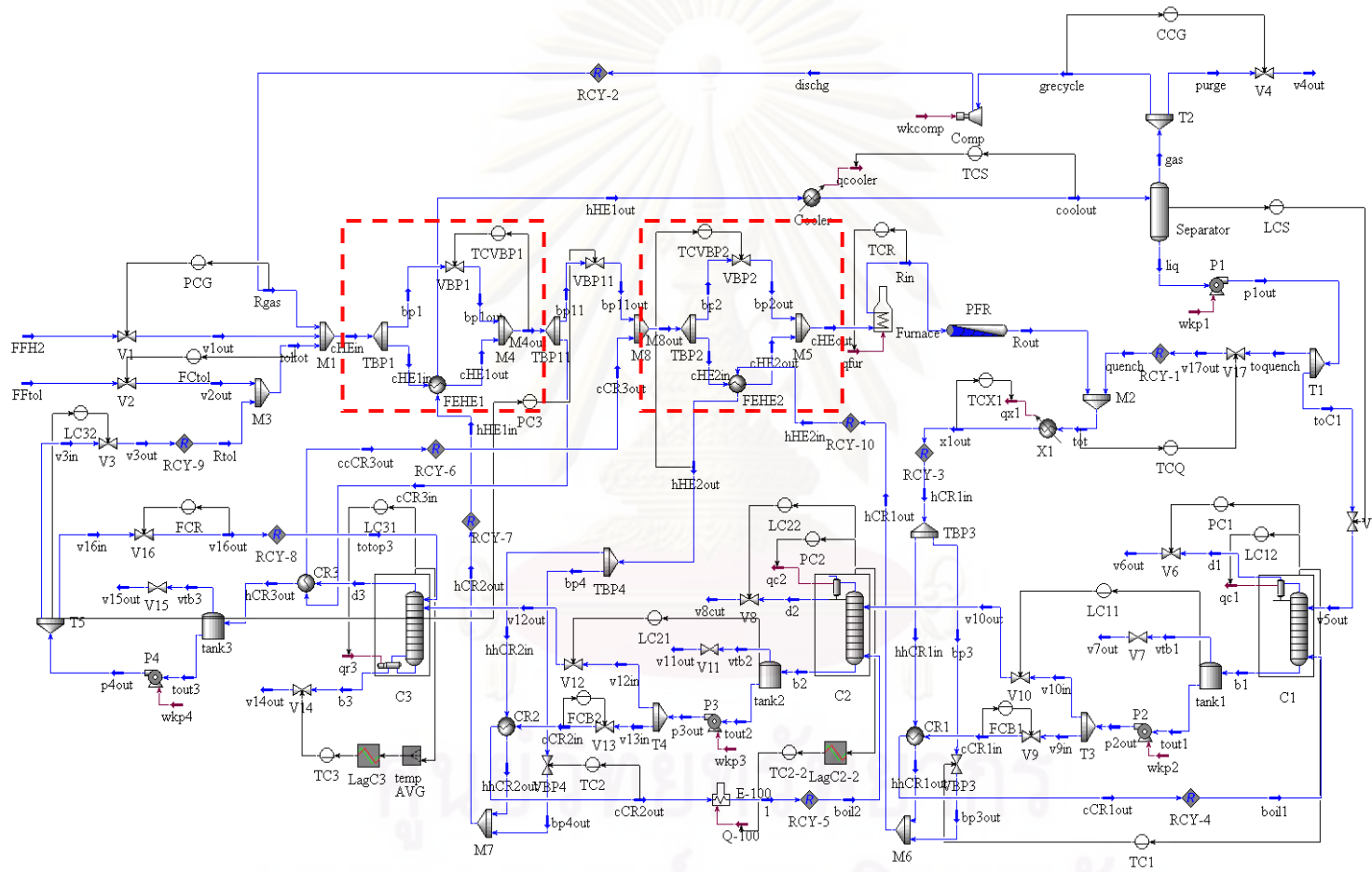

Figure 6.15 Control structure 1 (CS1) of the complex heat-integrated typical HDA process Alternative 5

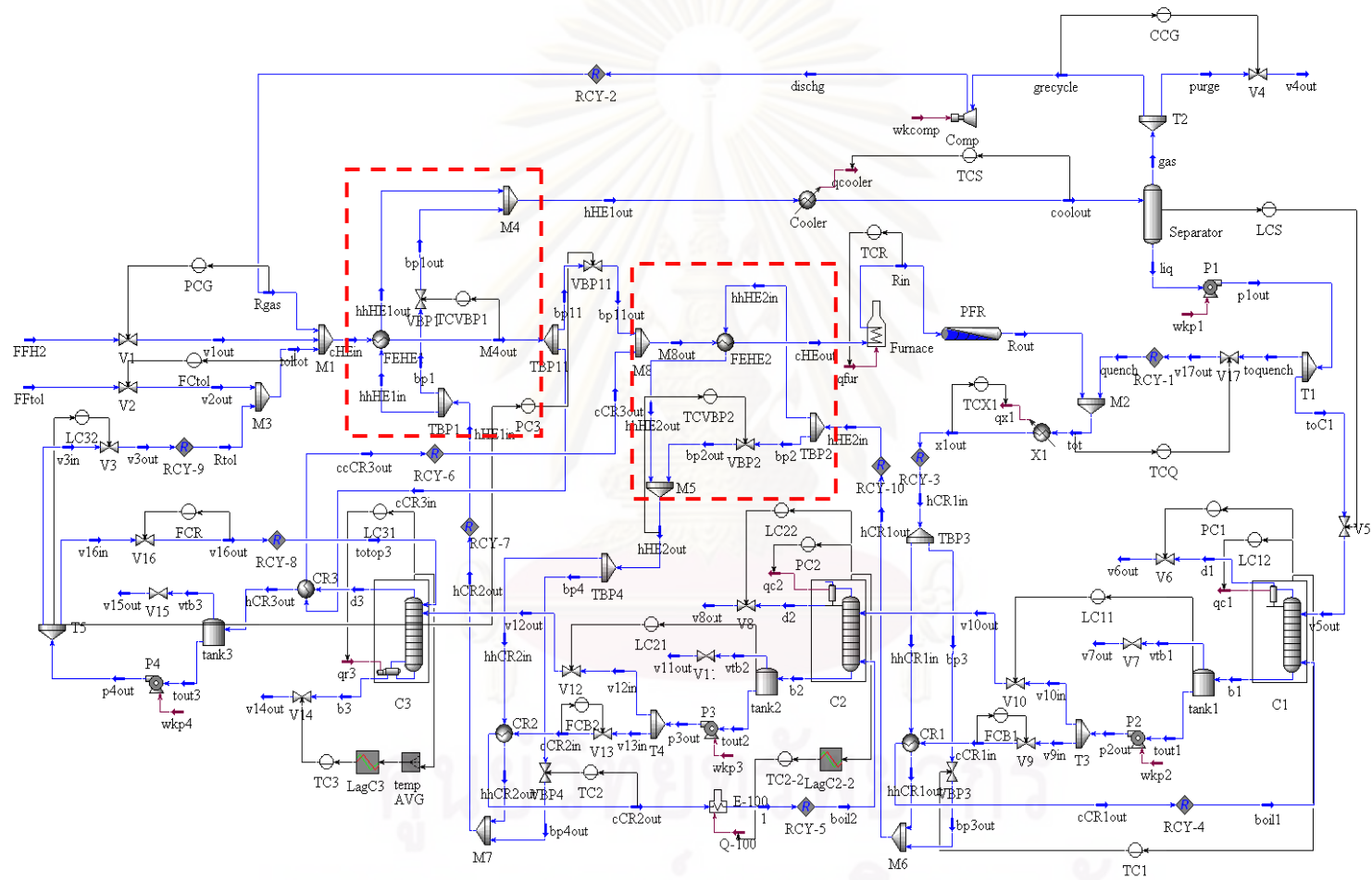

Figure 6.16 Control structure 2 (CS2) of the complex heat-integrated typical HDA process Alternative 5

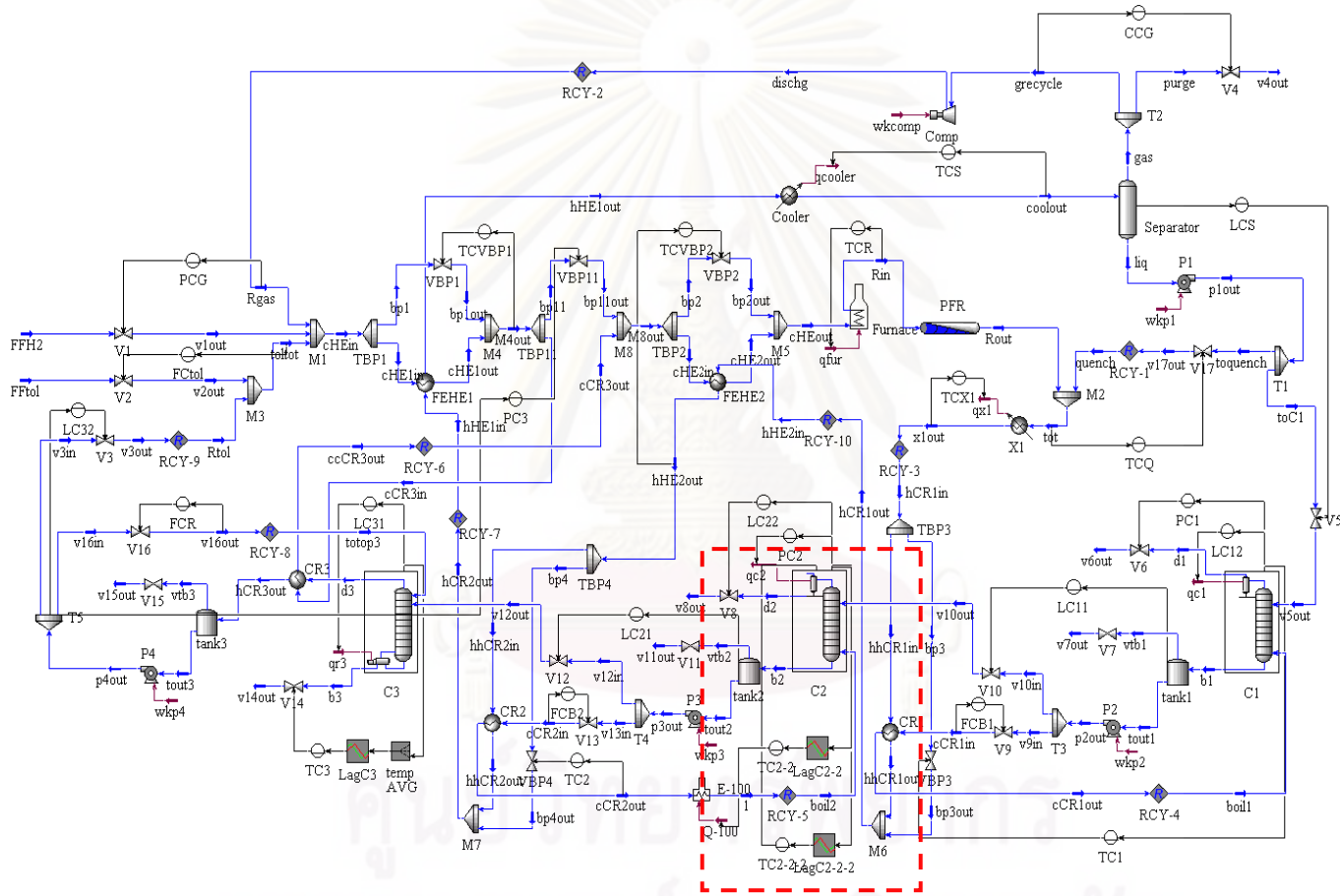

Figure 6.17 Control structure 3 (CS3) of the complex heat-integrated typical HDA process Alternative 5

6.3.1.4 Control Structure 1 (CS1) of Complex Heat-Integrated Typical HDA

Process HIP6.0

This control structure is shown in Figure 6.18 and the controller parameters are given in table 6.2. This control structure, the all bypass of feed effluent heat exchangers (FEHE) is on cold side. The major loops in HDA process HIP6.0 are the same as those used in HIP5.0. A heat exchanger (i.e. as a heat source or a heat sink) is artificially installed in the hot-side stream (i.e. the exchanger X1 in Fig. 6.18) in order to make the disturbance loads of the hot stream (i.e. the hot reactor product). Note that, this exchanger is not used in the real plant, and the temperature controller TCX1 is set to be “off” whenever it is not used to make the disturbances.

The control structure and controller parameter are given in table 6.2. P controllers are employed for level loops, PI controllers for the pressure and flow loops and PID controllers for temperature loops.

6.3.1.5 Control Structure 2 (CS2) of Complex Heat-Integrated Typical HDA

Process HIP6.0

The major loops in this control structure are the same as CS1 except for control loops of FEHE. The all bypass of FEHE are on hot side. This control structure is shown in Figure 6.19 and the controller parameters are given in Table 6.2.

6.3.1.6 Control Structure 3 (CS3) of Complex Heat-Integrated Typical HDA

Process HIP6.0

The major loops in this control structure are the same as CS1 except for temperature control in product distillation column. The temperature control in product distillation column is two point controls as the tray 12 and tray 17 temperature controls. This control structure is shown in Figure 6.20 and the controller parameters are given in Table 6.2

Table 6.2 Controller parameters for the complex heat-integrated typical HDA process alternative 6 (HIP6.0): control structure 1, control structure 2 and control structure 3

Controller	Controlled variable	Manipulated variable	Type	Kc	Ti	Td
Reaction section						
PCG	gas recycle stream pressure	fresh feed hydrogen valve (V1)	PI	2	10	-
Fctol	total toluene flow rate	fresh feed toluene valve (V2)	PI	0.5	0.3	-
TCVBP1	FEHE1 cold outlet temperature	FEHE1 bypass cold stream valve (VBP1)	PID	13.1	0.224	0.0497
TCVBP2	FEHE2 hot outlet temperature	FEHE2 bypass cold stream valve (VBP2)	PID	7.25	0.684	0.152
TCVBP1*	FEHE1 cold outlet temperature	FEHE1 bypass hot stream valve (VBP1)	PID	13.9	1.33	0.296
TCVBP2*	FEHE2 hot outlet temperature	FEHE2 bypass hot stream valve (VBP2)	PID	2.55	0.295	0.0655
TCQ	quenched temperature	quench valve (V21)	PID	0.395	0.404	0.0898
TCR	reactor inlet temperature	furnace duty (qfur)	PID	0.229	0.419	0.093
TCS	separator temperature	cooler duty (qcooler)	PID	2.49	0.297	0.066
CCG	methane in gas recycle	purge valve (V4)	PI	0.5	15	-
LCS	separator liquid level	column C1 feed valve (V5)	P	2	-	-
Separation section : Stabilizer column						
PC1	column C1 pressure	column C1 gas valve (V6)	PI	2	10	-
TC1	column C1 tray-6 temperature	CR1 bypass valve (VBP3)	PI	2	10	-
LC11	column C1 base level	column C2 feed valve (V10)	P	2	-	-
LC12	column C1 reflux drum level	column C1 condenser duty (qc1)	P	2	-	-
FCB1	column C1 boil up flow rate	CR1 cold inlet valve (V9)	PI	0.5	0.3	-
Product column						
PC2	column C2 pressure	column C2 condenser duty (qc2)	PI	2	10	-
TC2	CR2 cold outlet temperature	CR2 bypass valve (VBP4)	PID	13.6	0.78	0.173
TC2-2	column C2 tray-12 temperature	auxiliary reboiler duty (Q-100)	PID	2.70	3.71	0.824
TC2-2-2**	column C2 tray-17 temperature	column C2 reflux flow rate	PID	1.07	64.3	14.3
LC21	column C2 base level	column C3 feed valve (V12)	P	2	-	-
LC22	column C2 reflux drum level	column C2 product valve level (V8)	P	2	-	-
FCB2	column C2 boil up flow rate	CR2 cold inlet valve (V13)	PI	0.5	0.3	-
Recycle column						
PC3	column C3 pressure	CR3 bypass valve (VBP11)	PI	2	10	-
TC3	AVG avg. temp. of C3 tray-1, 2, 3 and 4	CR bypass valve (VBP5)	PID	0.544	30.2	6.71
LC31	column C3 base level	column C3 by-product valve (V16)	P	2	-	-
LC32	column C3 reflux drum level	toluene recycle valve (V3)	P	2	-	-
FCB3	column C3 boil up flow rate	CR cold inlet valve (V17)	PI	0.5	0.3	-
FCR	column C3 reflux flow rate	reflux valve (V18)	PI	0.5	0.3	-

*TCVBP1 and 2 controllers are used in only control structure 2 (CS2).

**TC2-2-2 controller is used in only control structure 3 (CS3).

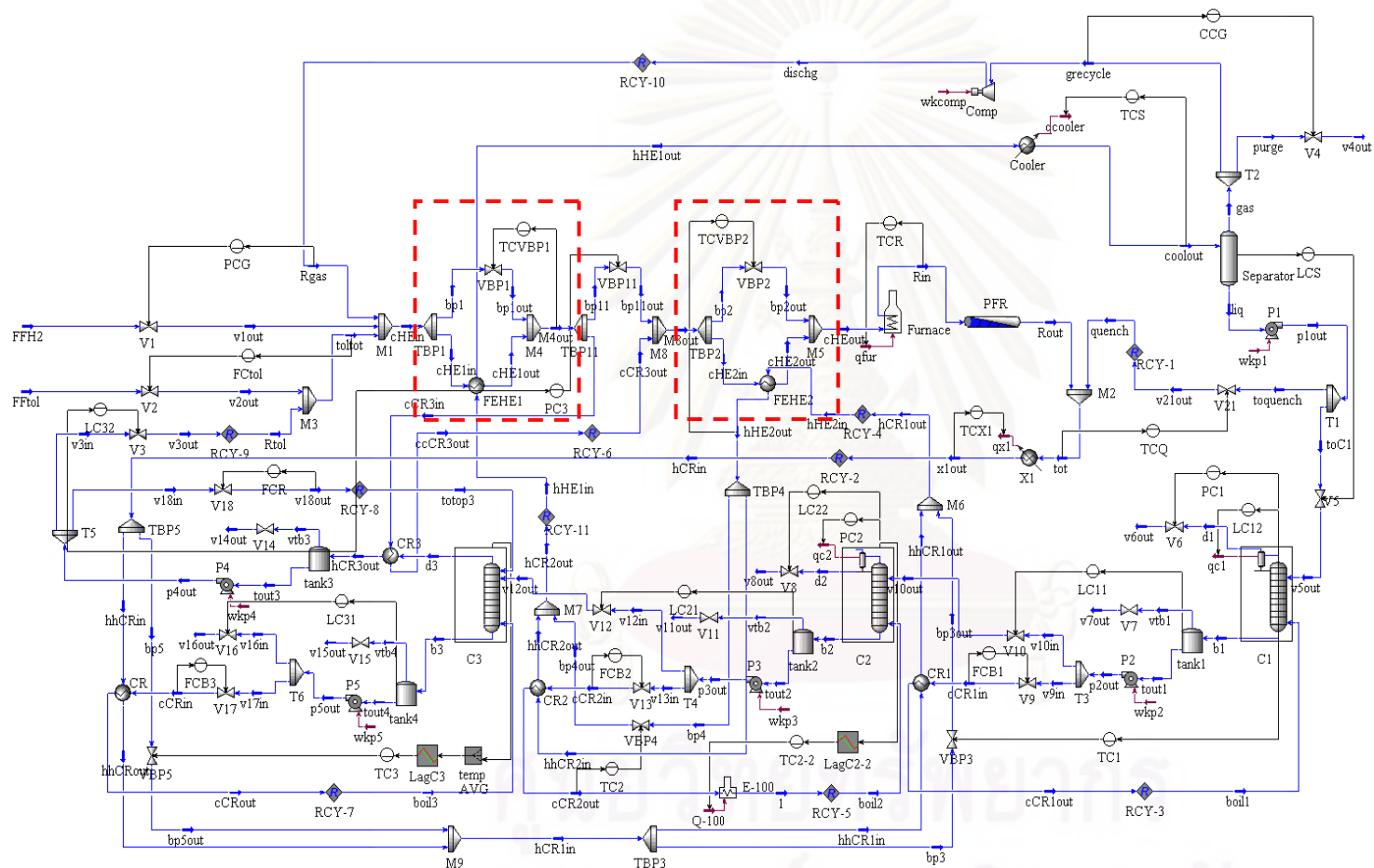

Figure 6.18 Control structure 1 (CS1) of the complex heat-integrated typical HDA process Alternative 6

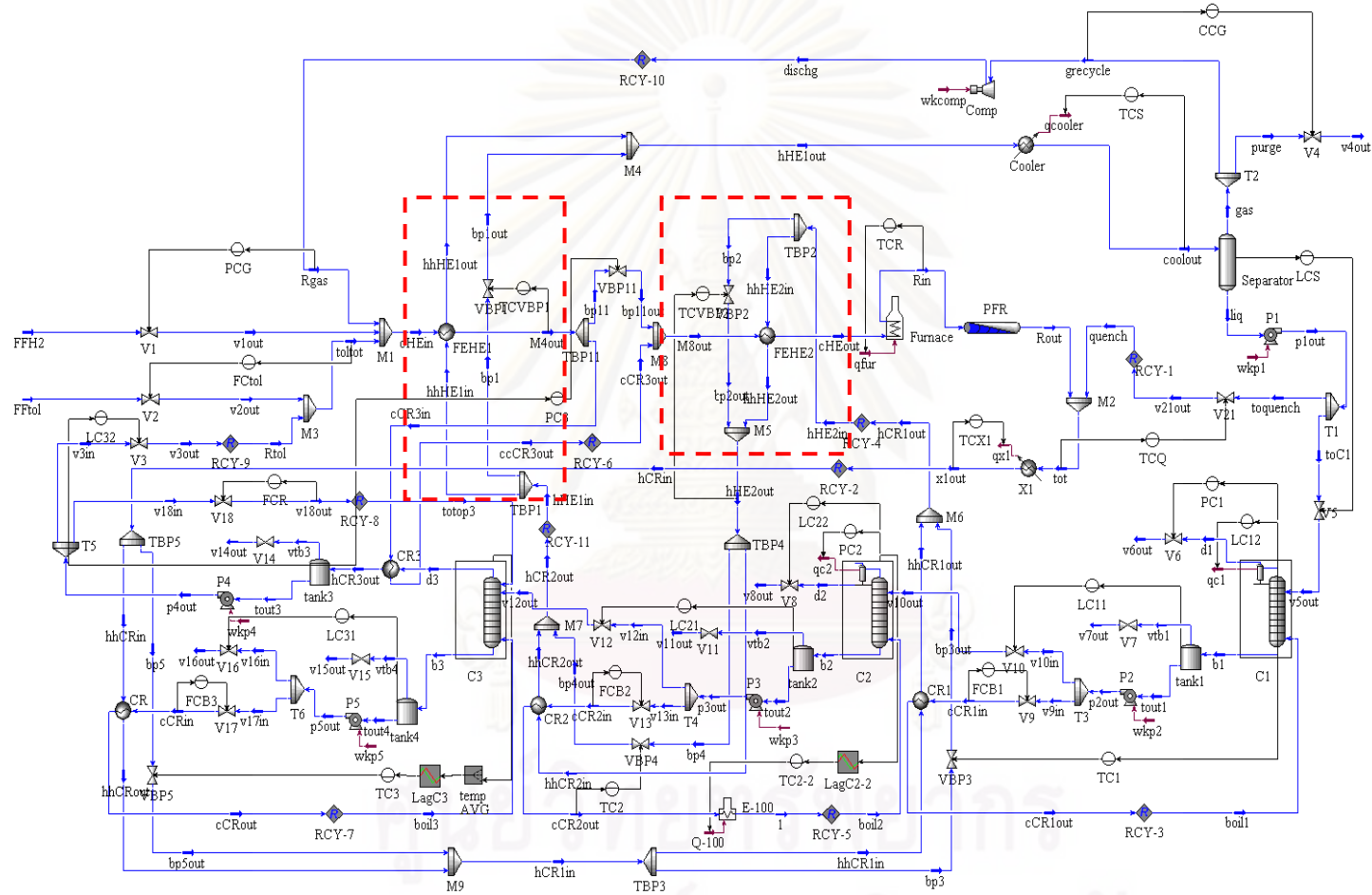

Figure 6.19 Control structure 2 (CS2) of the complex heat-integrated typical HDA process Alternative 6

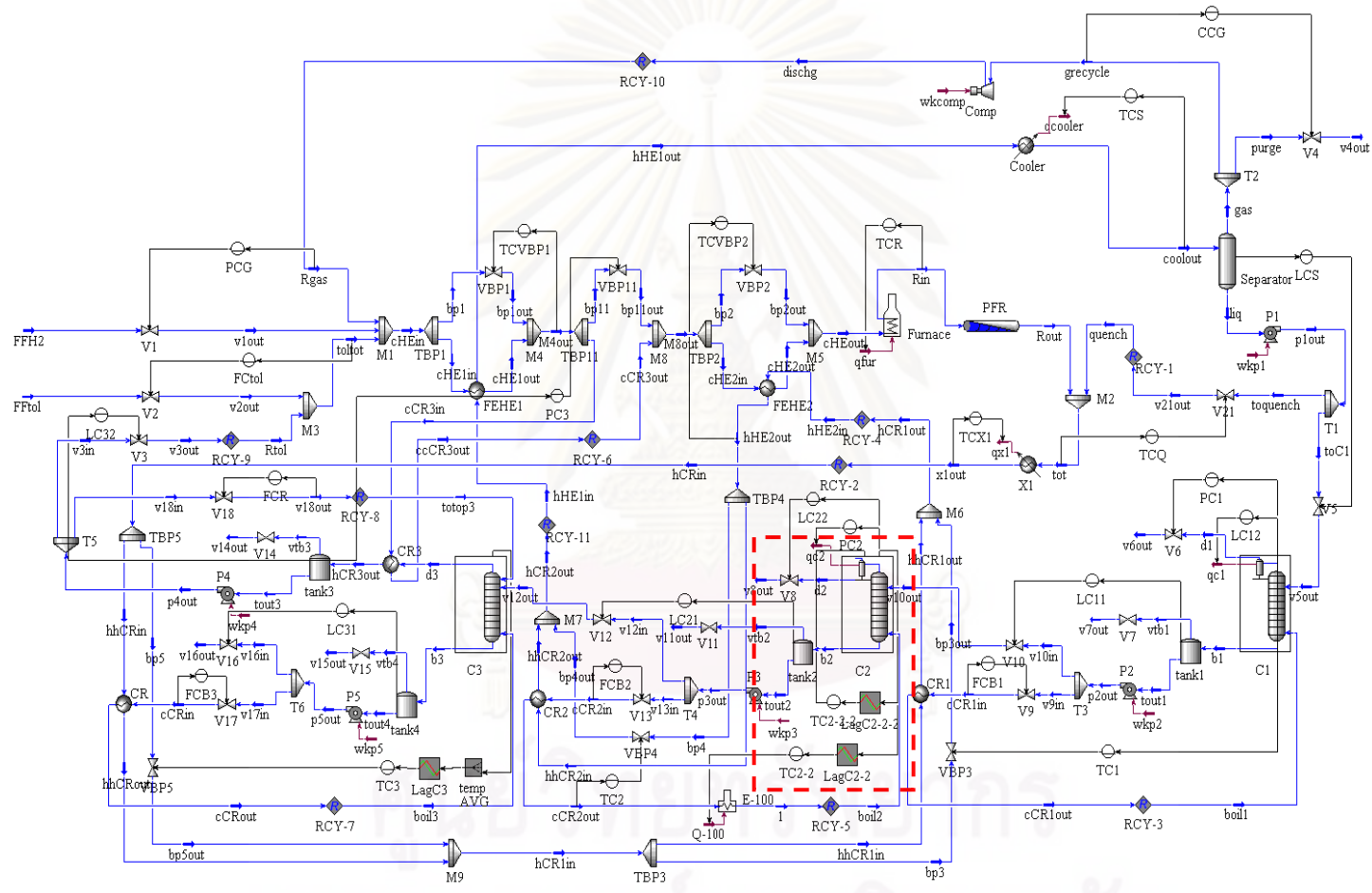

Figure 6.20 Control structure 3 (CS3) of the complex heat-integrated typical HDA process Alternative 6

6.3.2 Plantwide Control Structures of Complex Heat-Integrated HDA Process (HIP5.1, HIP5.2, HIP6.1, HIP6.2 and HIP6.3)

The three control structures are designed for the complex heat-integrated HDA process HIP5.1, 5.2, 6.1, 6.2 and 6.3 that are propose in this research.

6.3.2.1 Control structure 1 (CS1) of Complex Heat-Integrated HDA Process HIP5.1 and HIP5.2

The control structure CS1 of HIP5.1 and HIP5.2 are shown in Figure 6.21 and 6.24, respectively. The controller parameters are given in table 6.3. This control structure, the all bypass of feed effluent heat exchangers (FEHE) is on cold side. The major loops in HDA process HIP5.1 and HIP5.2 are the same as those used HIP5.0, for the outlet temperature control in FEHE and the tray temperature control in the recycle column (C3). The furnace inlet temperature is controlled by manipulating the valve on the bypass line based on the heat pathway heuristics for plantwide control. The controller parameters are given in table 6.3. P controllers are employed for level loops, PI controllers for the pressure and flow loops and PID controllers for temperature loops.

6.3.2.2 Control structure 2 (CS2) of Complex Heat-Integrated HDA Process HIP5.1 and HIP5.2

The major loops in this control structure are the same as CS1 except for control loops of FEHE. The all bypass of FEHE are on hot side. The CS2 of HIP5.1 and HIP5.2 are shown in Figure 6.22 and 6.25, respectively. The controller parameters are given in Table 6.3.

6.3.2.3 Control structure 3 (CS3) of Complex Heat-Integrated HDA Process HIP5.1 and HIP5.2

The major loops in this control structure are the same as CS1 except for temperature control in product distillation column. The temperature control in product distillation column is two point controls as the bottom stage temperature and tray 2 temperature controls. The CS3 of HIP5.1 and HIP5.2 are shown in Figure 6.23 and 6.26, respectively. The controller parameters are given in Table 6.3.

Table 6.3 Controller parameters for the complex heat-integrated HDA process HIP5
(Both HIP5.1 and 5.2): control structure 1, control structure 2 and control structure 3

Controller	Controlled variable	Manipulated variable	Type	Kc	Ti	Td
Reaction section						
PCG	gas recycle stream pressure	fresh feed hydrogen valve (V1)	PI	2	10	-
Fctol	total toluene flow rate	fresh feed toluene valve (V2)	PI	0.5	0.3	-
TCVBP1	FEHE1 cold outlet temperature	FEHE1 bypass cold stream valve (VBP1)	PID	4.86	0.236	0.0525
TCVBP2	FEHE2 hot outlet temperature	FEHE2 bypass cold stream valve (VBP2)	PID	11	0.609	0.135
TCVBP1*	FEHE1 cold outlet temperature	FEHE1 bypass hot stream valve (VBP1)	PID	13.6	0.436	0.0969
TCVBP2*	FEHE2 hot outlet temperature	FEHE2 bypass hot stream valve (VBP2)	PID	2.23	0.306	0.068
TCQ	quenched temperature	quench valve (V15)	PID	0.406	0.403	0.0896
TCR	reactor inlet temperature	furnace duty (q _{fur})	PID	0.212	0.420	0.0934
TCS	separator temperature	cooler duty (q _{cooler})	PID	1.91	0.318	0.0707
CCG	methane in gas recycle	purge valve (V4)	PI	0.5	15	-
LCS	separator liquid level	column C1 feed valve (V5)	P	2	-	-
Separation section : Stabilizer column						
PC1	column C1 pressure	column C1 condenser duty (q _{c1})	PI	2	10	-
TC1	column C1 tray-14 temperature	CR1 bypass valve (VBP4)	PID	14.7	12.4	2.74
LC11	column C1 base level	column C3 feed valve (V10)	P	2	-	-
LC12	column C1 reflux drum level	column C2 gas feed valve (V6)	P	2	-	-
FCCR1	column C1 boil up flow rate	CR1 cold inlet valve (V11)	PI	0.5	0.3	-
Product column						
PC2	column C2 pressure	column C2 condenser duty (q _{c2})	PI	2	10	-
TC2	column C2 bottom stage temperature	column C2 reboiler duty (q _{r2})	P	2	-	-
TC2-2**	column C2 tray-2 temperature	column C2 reflux flow rate	PID	14.6	0.650	0.144
LC21	column C2 base level	column C2 product valve (V8)	P	2	-	-
LC22	column C2 reflux drum level	column C2 gas valve (V7)	P	2	-	-
Recycle column						
PC3	column C3 pressure	column C3 condenser duty (q _{c3})	PI	2	10	-
TC3	CR3 cold outlet temperature	CR3 bypass valve (VBP3)	PI	0.1	0.1	-
LC31	column C3 base level	column C3 by-product valve (V13)	P	2	-	-
LC32	column C3 reflux drum level	toluene recycle valve (V3)	P	2	-	-
FCCR3	column C3 boil up flow rate	CR3 cold inlet valve (V14)	PI	0.5	0.3	-

*TCVBP1 and 2 controllers are used in only control structure 2 (CS2).

**TC2-2 controller is used in only control structure 3 (CS3).

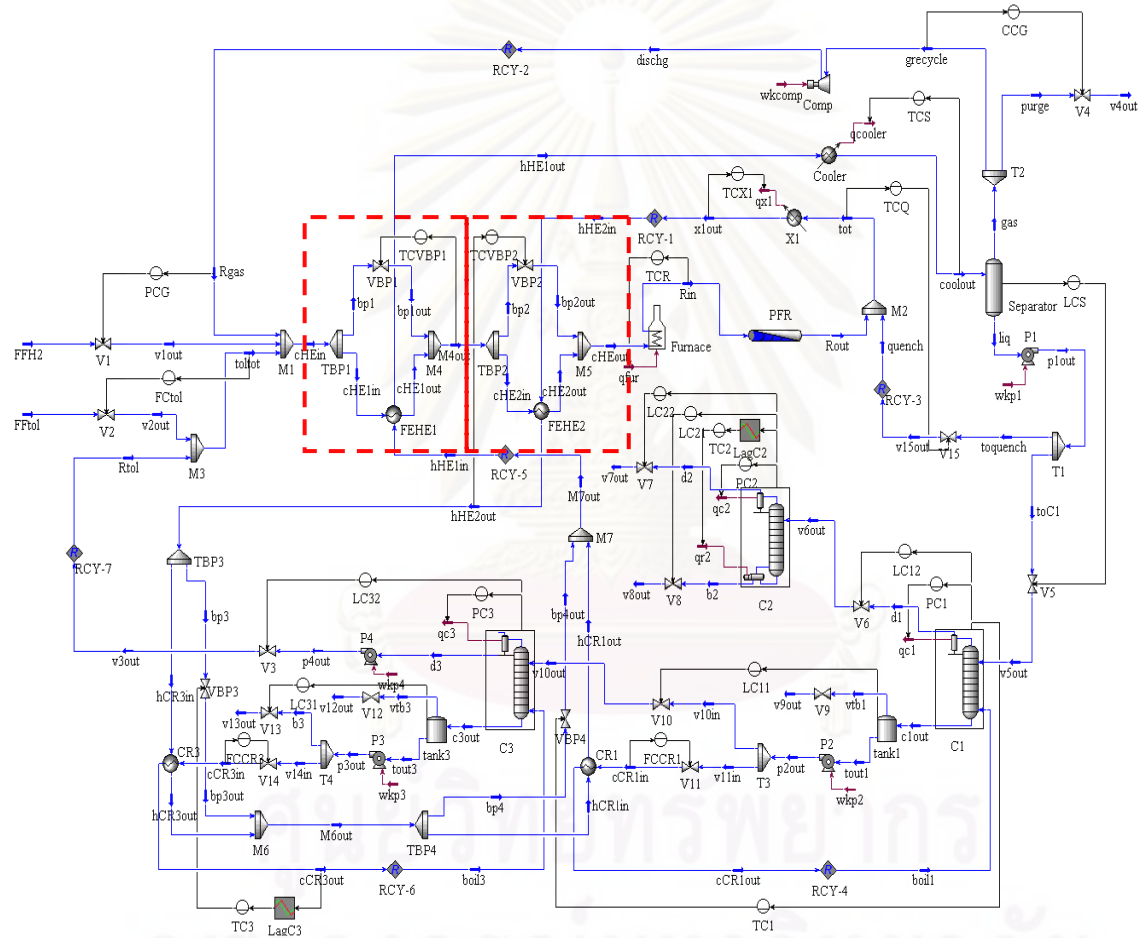

Figure 6.21 Control structure 1 (CS1) of the complex heat-integrated HDA process HIP5.1

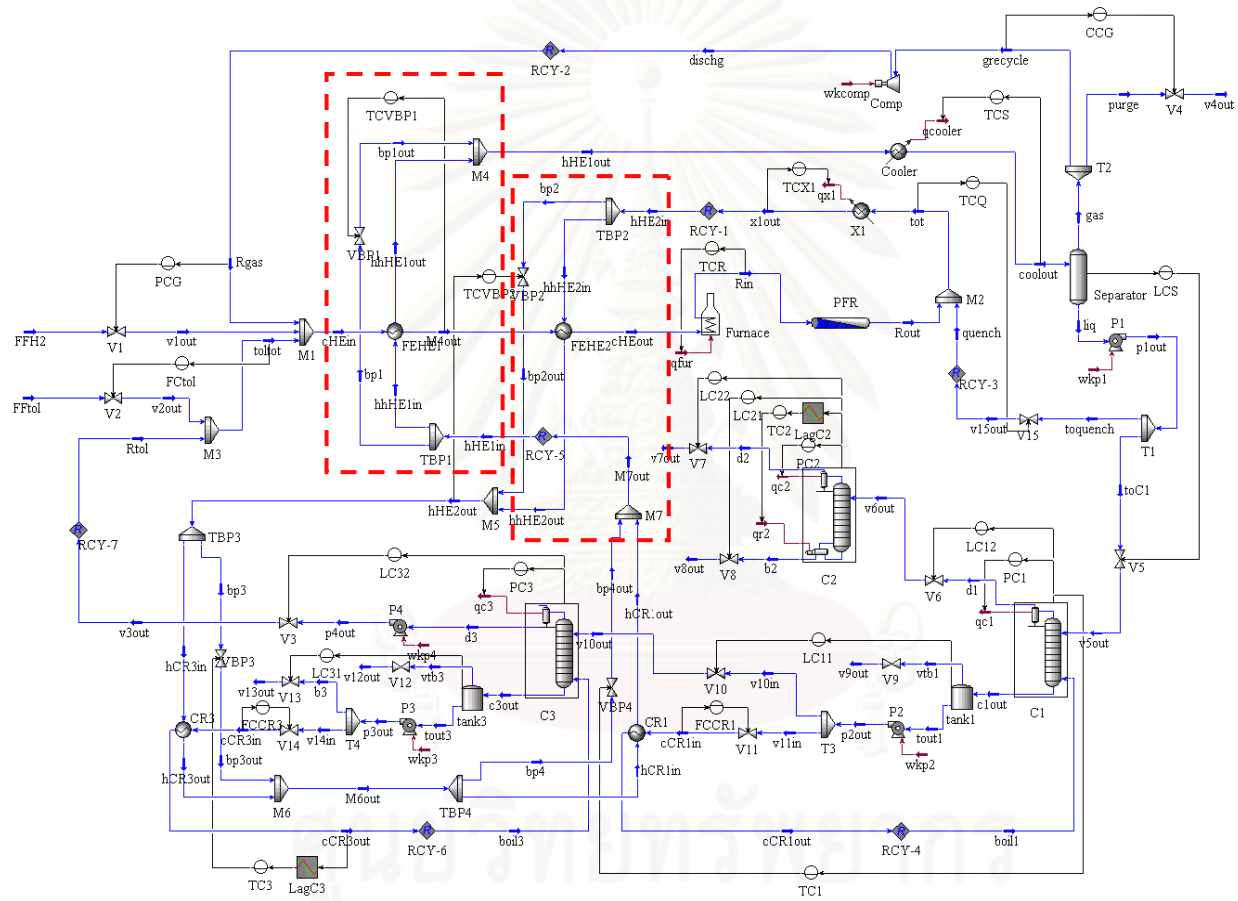

Figure 6.22 Control structure 2 (CS2) of the complex heat-integrated HDA process HIP5.1

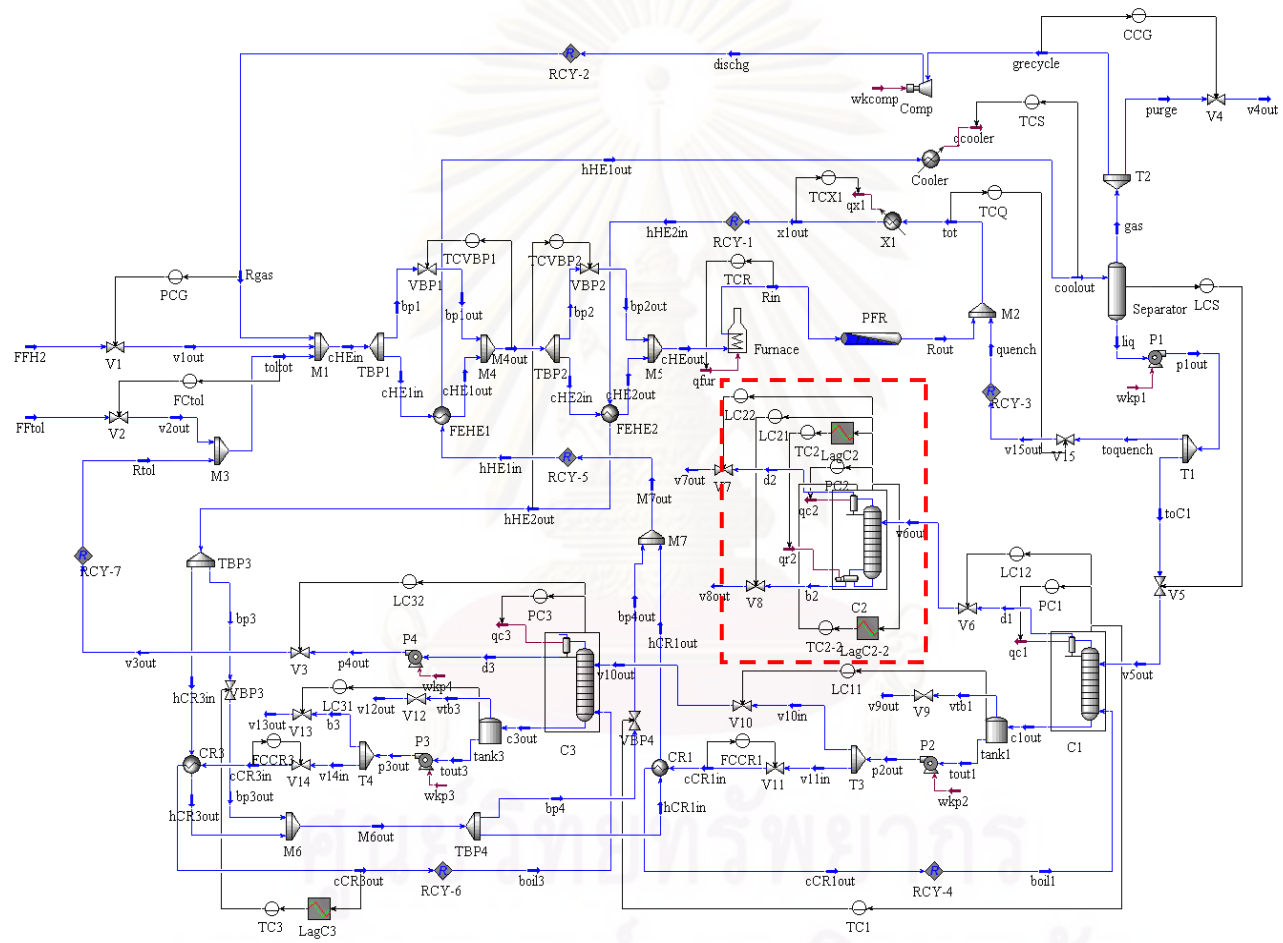

Figure 6.23 Control structure 3 (CS3) of the complex heat-integrated HDA process HIP5.1

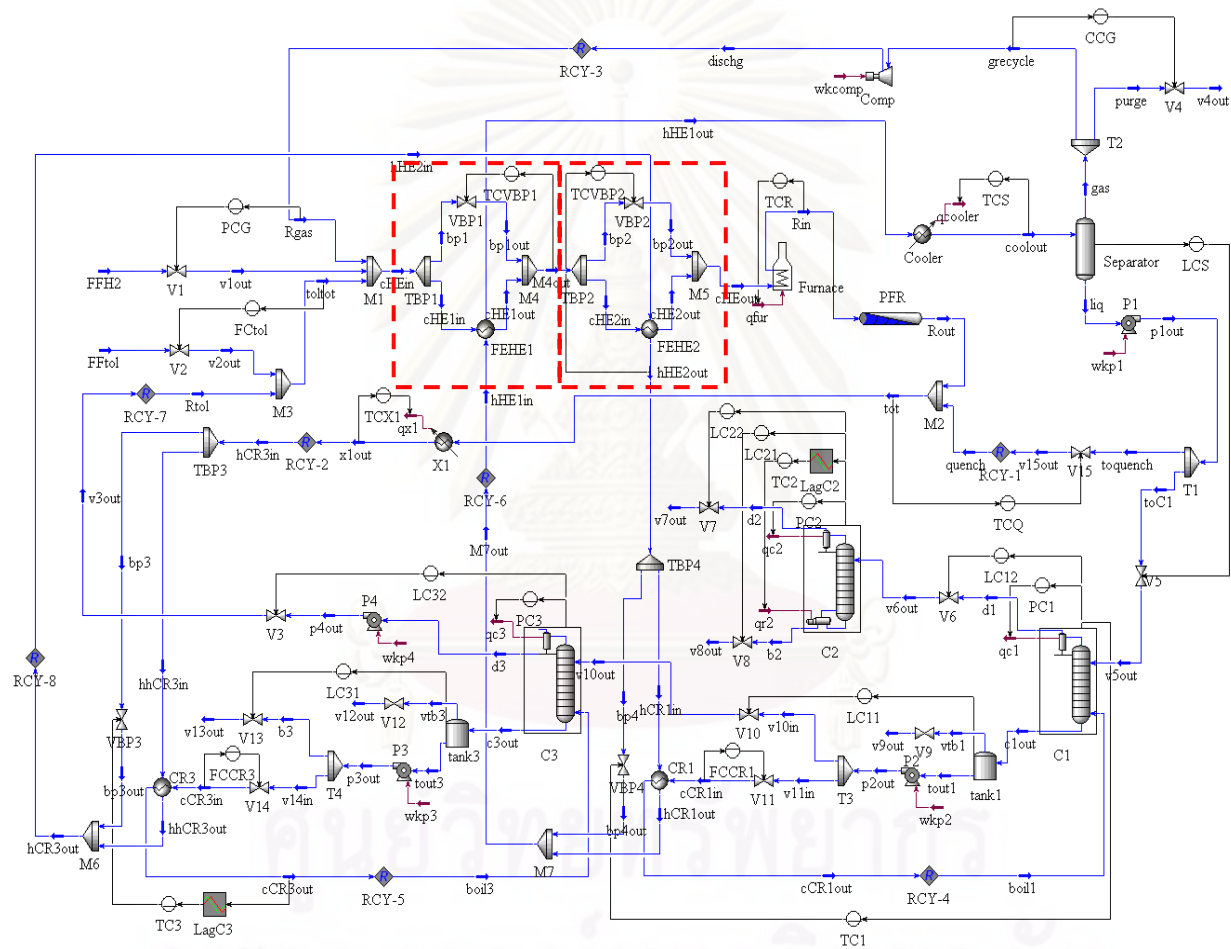

Figure 6.24 Control structure 1 (CS1) of the complex heat-integrated HDA process HIP5.2

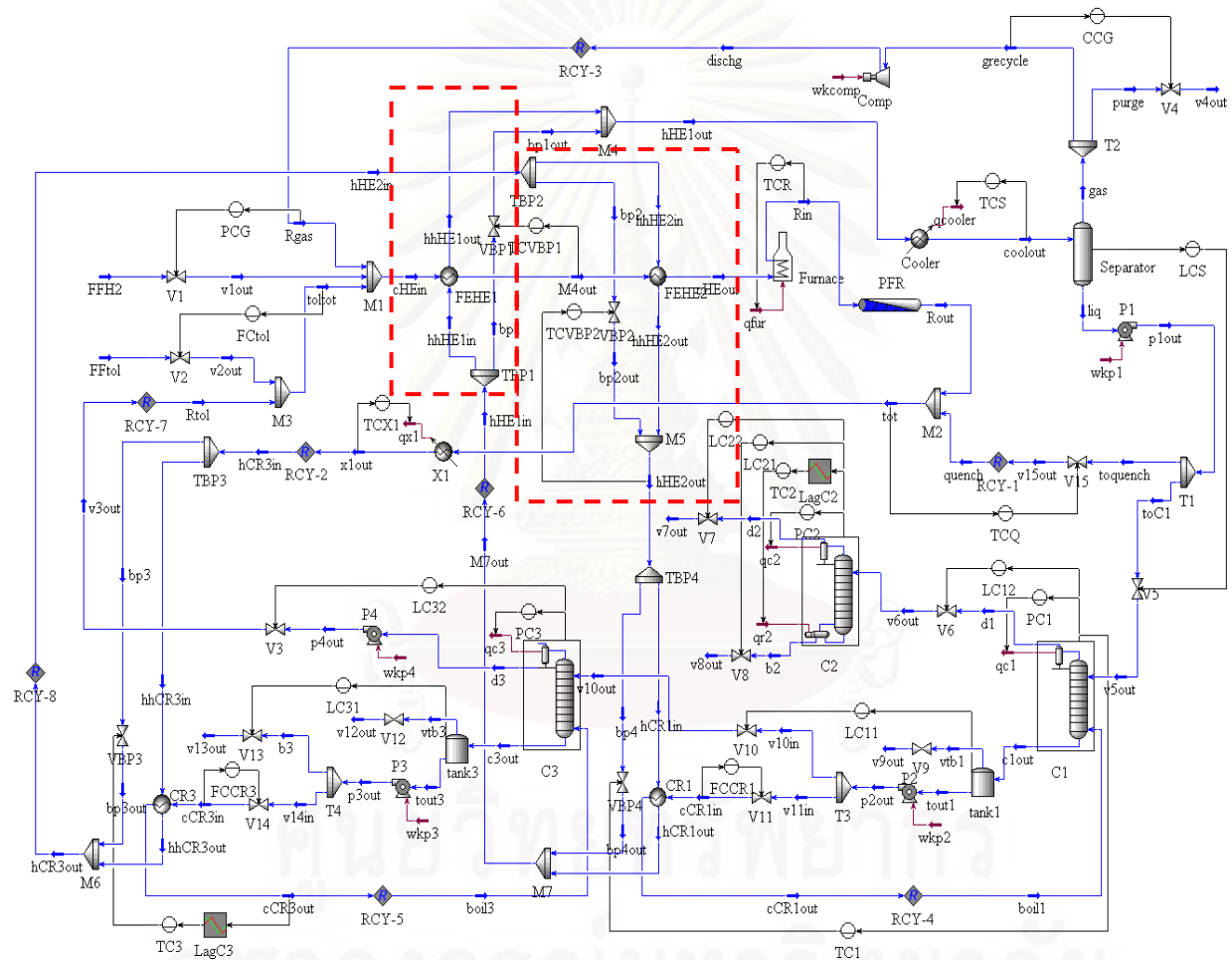

Figure 6.25 Control structure 2 (CS2) of the complex heat-integrated HDA process HIP5.2

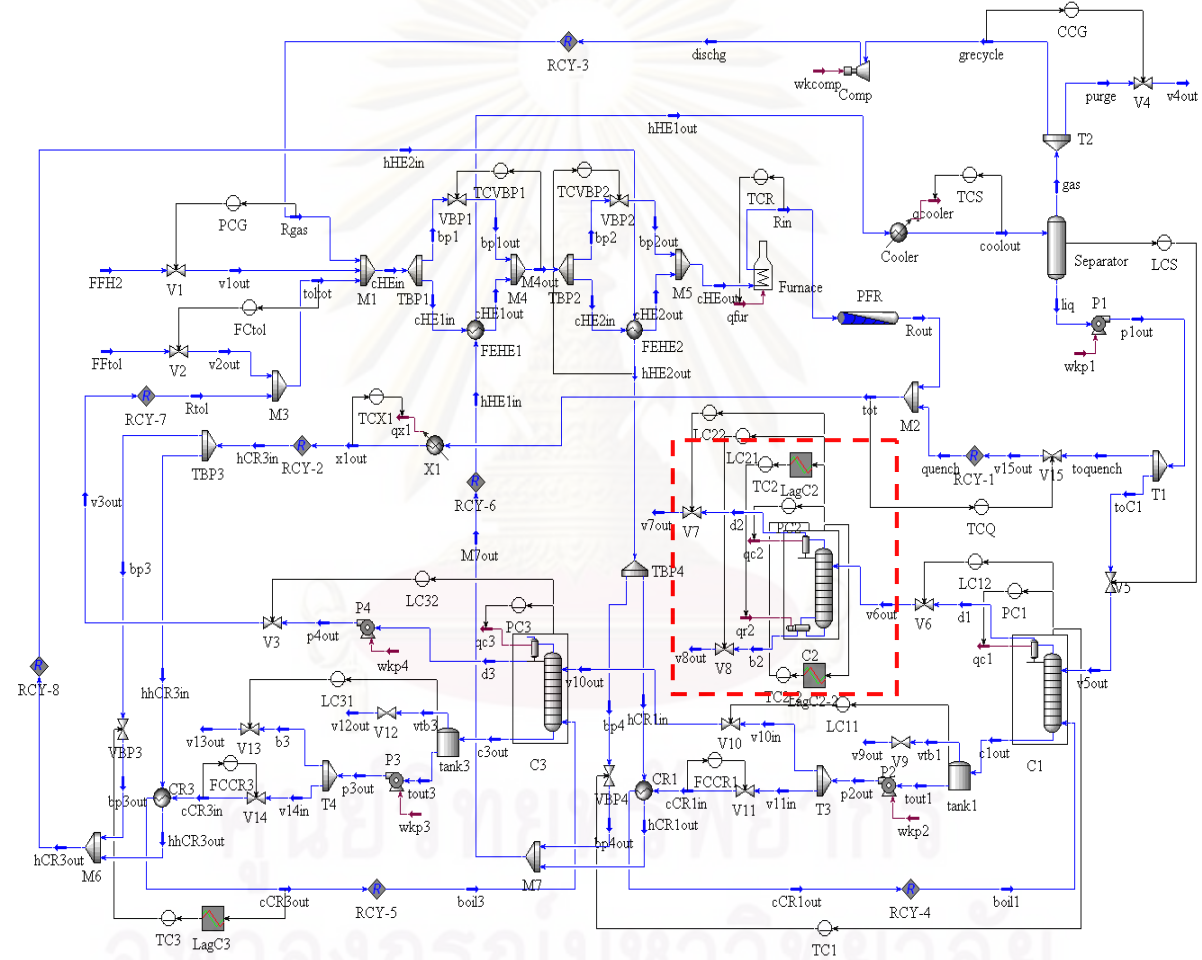

Figure 6.26 Control structure 3 (CS3) of the complex heat-integrated HDA process HIP5.2

6.3.2.4 Control structure 1 (CS1) of Complex Heat-Integrated HDA Process

HIP6.1, HIP6.2 and HIP6.3

The control structure CS1 of HIP6.1, HIP6.2 and HIP6.3 are shown in Figure 6.27, 6.30 and 6.33, respectively. The controller parameters are given in table 6.4. This control structure, the all bypass of feed effluent heat exchangers (FEHE) is on cold side. The major loops in HDA process HIP6.1, HIP6.2 and HIP6.3 are the same as those used HIP6.0, for the outlet temperature control in FEHE and the tray temperature control in the recycle column (C3). The furnace inlet temperature is controlled by manipulating the valve on the bypass line based on the heat pathway heuristics for plantwide control. The controller parameters are given in table 6.4. P controllers are employed for level loops, PI controllers for the pressure and flow loops and PID controllers for temperature loops.

6.3.2.5 Control structure 2 (CS2) of Complex Heat-Integrated HDA Process

HIP6.1, HIP6.2 and HIP6.3

The major loops in this control structure are the same as CS1 except for control loops of FEHE. The all bypass of FEHE are on hot side. The CS2 of HIP6.1, HIP6.2 and HIP6.3 are shown in Figure 6.28, 6.31 and 6.34, respectively. The controller parameters are given in Table 6.4.

6.3.2.6 Control structure 3 (CS3) of Complex Heat-Integrated HDA Process

HIP6.1, HIP6.2 and HIP6.3

The major loops in this control structure are the same as CS1 except for temperature control in product distillation column. The temperature control in product distillation column is two point controls as the bottom stage temperature and tray 2 temperature controls. The CS3 of HIP6.1, HIP6.2 and HIP6.3 are shown in Figure 6.29, 6.32 and 6.35, respectively. The controller parameters are given in Table 6.4.

Table 6.4 Controller parameters for the complex heat-integrated HDA process HIP6 (HIP6.1, 6.2 and 6.3): control structure 1, control structure 2 and control structure 3

Controller	Controlled variable	Manipulated variable	Type	Kc	Ti	Td
Reaction section						
PCG	gas recycle stream pressure	fresh feed hydrogen valve (V1)	PI	2	10	-
Fctol	total toluene flow rate	fresh feed toluene valve (V2)	PI	0.5	0.3	-
TCVBP1	FEHE1 cold outlet temperature	FEHE1 bypass cold stream valve (VBP1)	PID	6.53	0.206	0.0459
TCVBP2	FEHE2 hot outlet temperature	FEHE2 bypass cold stream valve (VBP2)	PID	10.4	0.542	0.120
TCVBP1*	FEHE1 cold outlet temperature	FEHE1 bypass hot stream valve (VBP1)	PID	14.3	0.828	0.184
TCVBP2*	FEHE2 hot outlet temperature	FEHE2 bypass hot stream valve (VBP2)	PID	3.09	0.285	0.0634
TCQ	quenched temperature	quench valve (V17)	PID	0.393	0.404	0.0898
TCR	reactor inlet temperature	furnace duty (q _{fur})	PID	0.2	0.421	0.0937
TCS	separator temperature	cooler duty (q _{cooler})	PID	1.92	0.318	0.0706
CCG	methane in gas recycle	purge valve (V4)	PI	0.5	15	-
LCS	separator liquid level	column C1 feed valve (V5)	P	2	-	-
Separation section : Stabilizer column						
PC1	column C1 pressure	column C1 condenser duty (q _{c1})	PI	2	10	-
TC1	column C1 tray-14 temperature	CR1 bypass valve (VBP4)	PID	14.8	8.15	1.81
LC11	column C1 base level	column C3 feed valve (V12)	P	2	-	-
LC12	column C1 reflux drum level	column C2 gas feed valve (V6)	P	2	-	-
FCCR1	column C1 boil up flow rate	CR1 cold inlet valve (V13)	PI	0.5	0.3	-
Product column						
PC2	column C2 pressure	column C2 condenser duty (q _{c2})	PI	2	10	-
TC2	CR2 cold outlet temperature	CR2 bypass valve (VBP5)	P	2	-	-
TC2-2**	column C2 tray-2 temperature	column C2 reflux flow rate	PID	13.5	0.497	0.110
LC21	column C2 base level	column C2 product valve (V8)	P	2	-	-
LC22	column C2 reflux drum level	column C2 gas valve (V7)	P	2	-	-
Recycle column						
PC3	column C3 pressure	column C3 condenser duty (q _{c3})	PI	2	10	-
TC3	CR3 cold outlet temperature	CR3 bypass valve (VBP3)	PI	0.1	0.1	-
LC31	column C3 base level	column C3 by-product valve (V15)	P	2	-	-
LC32	column C3 reflux drum level	toluene recycle valve (V3)	P	2	-	-
FCCR3	column C3 boil up flow rate	CR3 cold inlet valve (V16)	PI	0.5	0.3	-

*TCVBP1 and 2 controllers are used in only control structure 2 (CS2).

**TC2-2 controller is used in only control structure 3 (CS3).

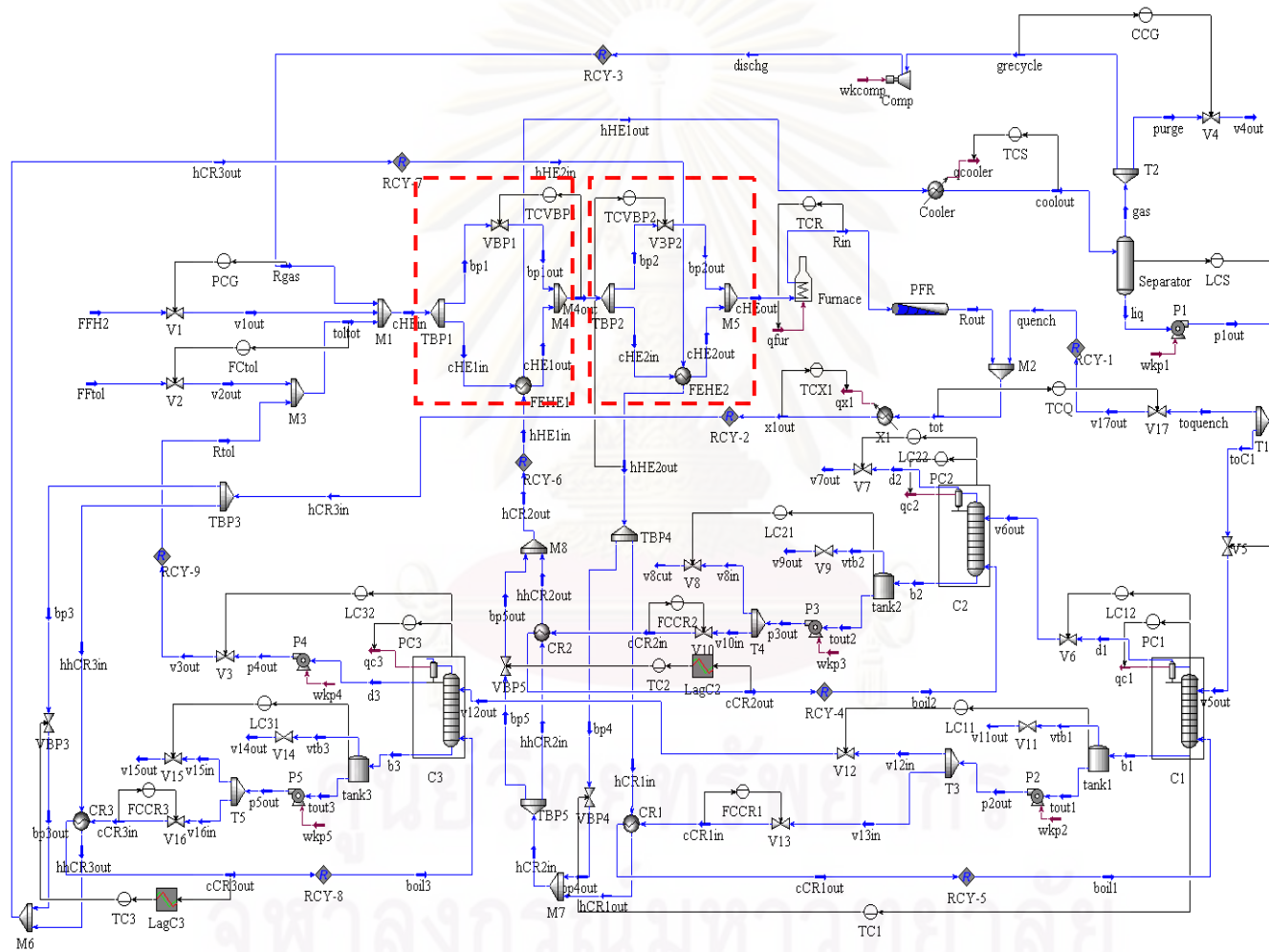

Figure 6.27 Control structure 1 (CS1) of the complex heat-integrated HDA process HIP6.1

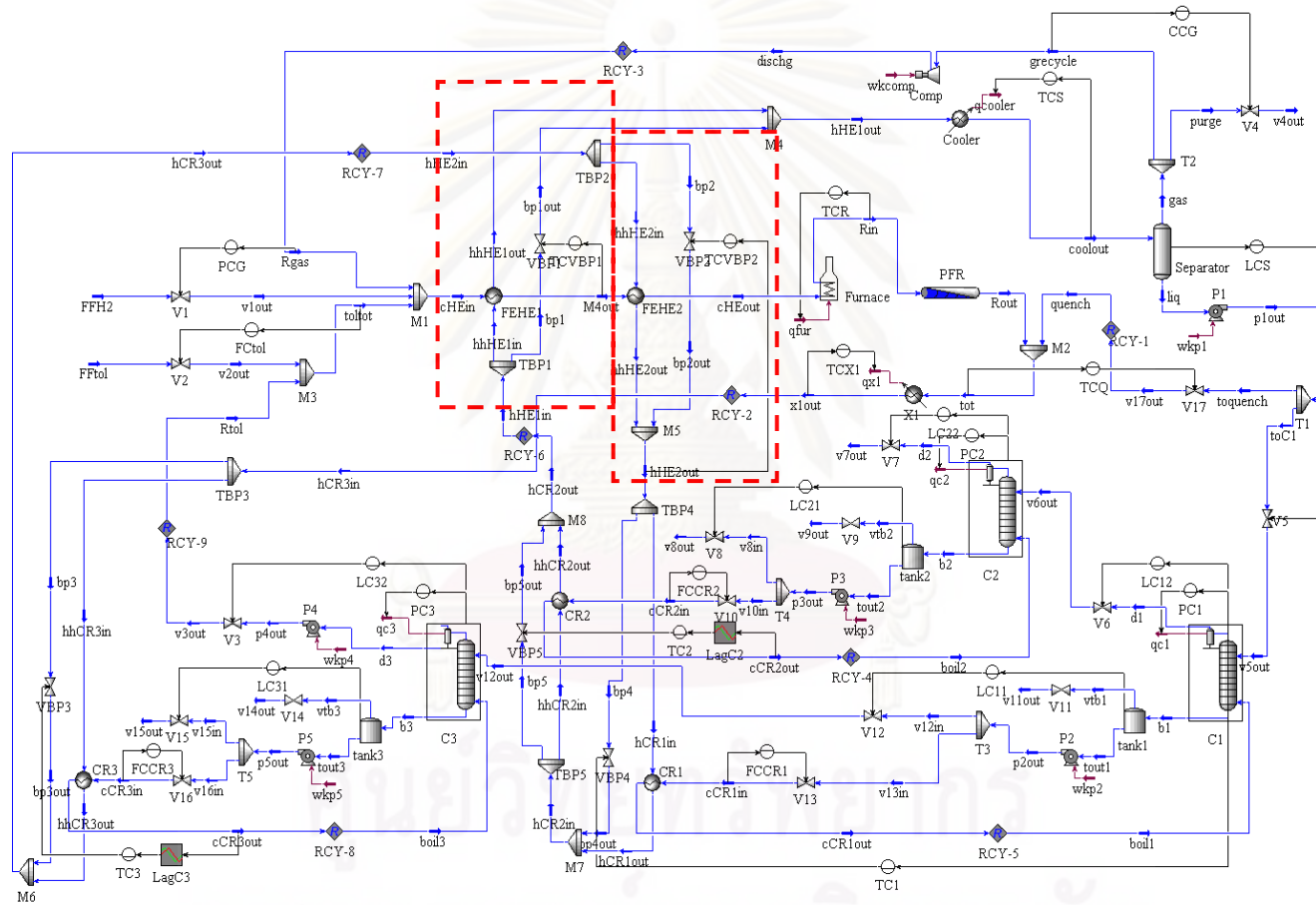

Figure 6.28 Control structure 2 (CS2) of the complex heat-integrated HDA process HIP6.1

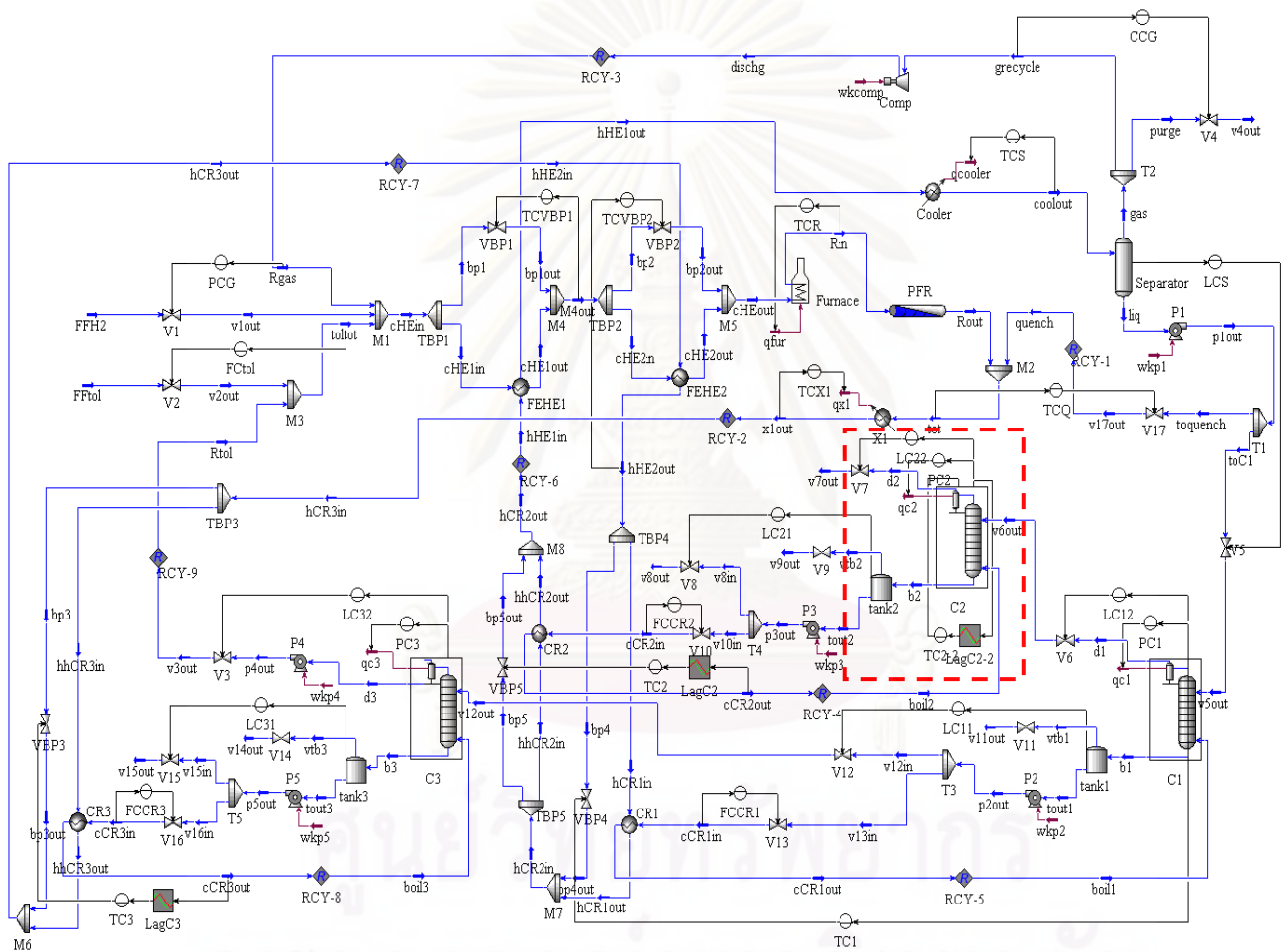

Figure 6.29 Control structure 3 (CS3) of the complex heat-integrated HDA process HIP6.1

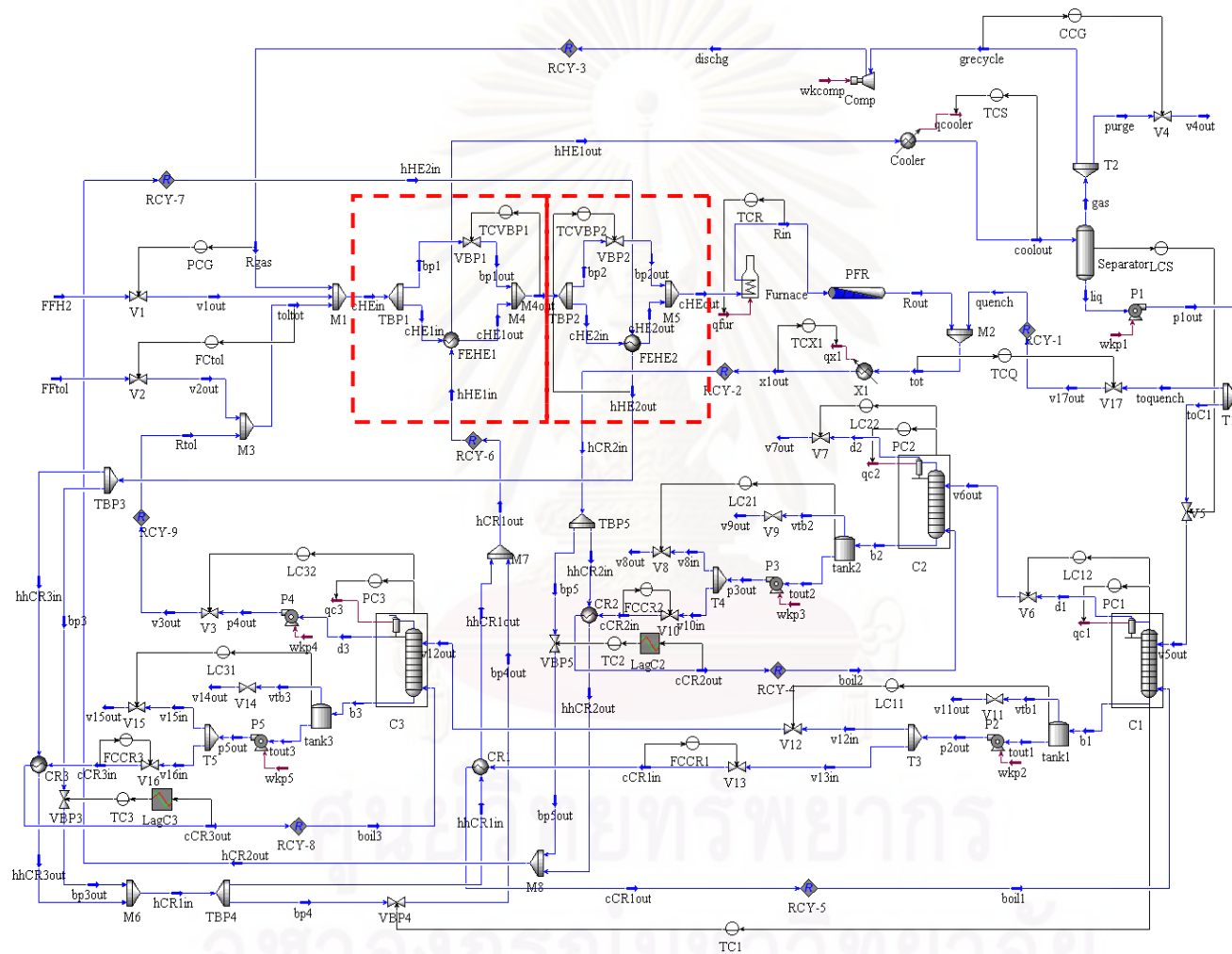

Figure 6.30 Control structure 1 (CS1) of the complex heat-integrated HDA process HIP6.2

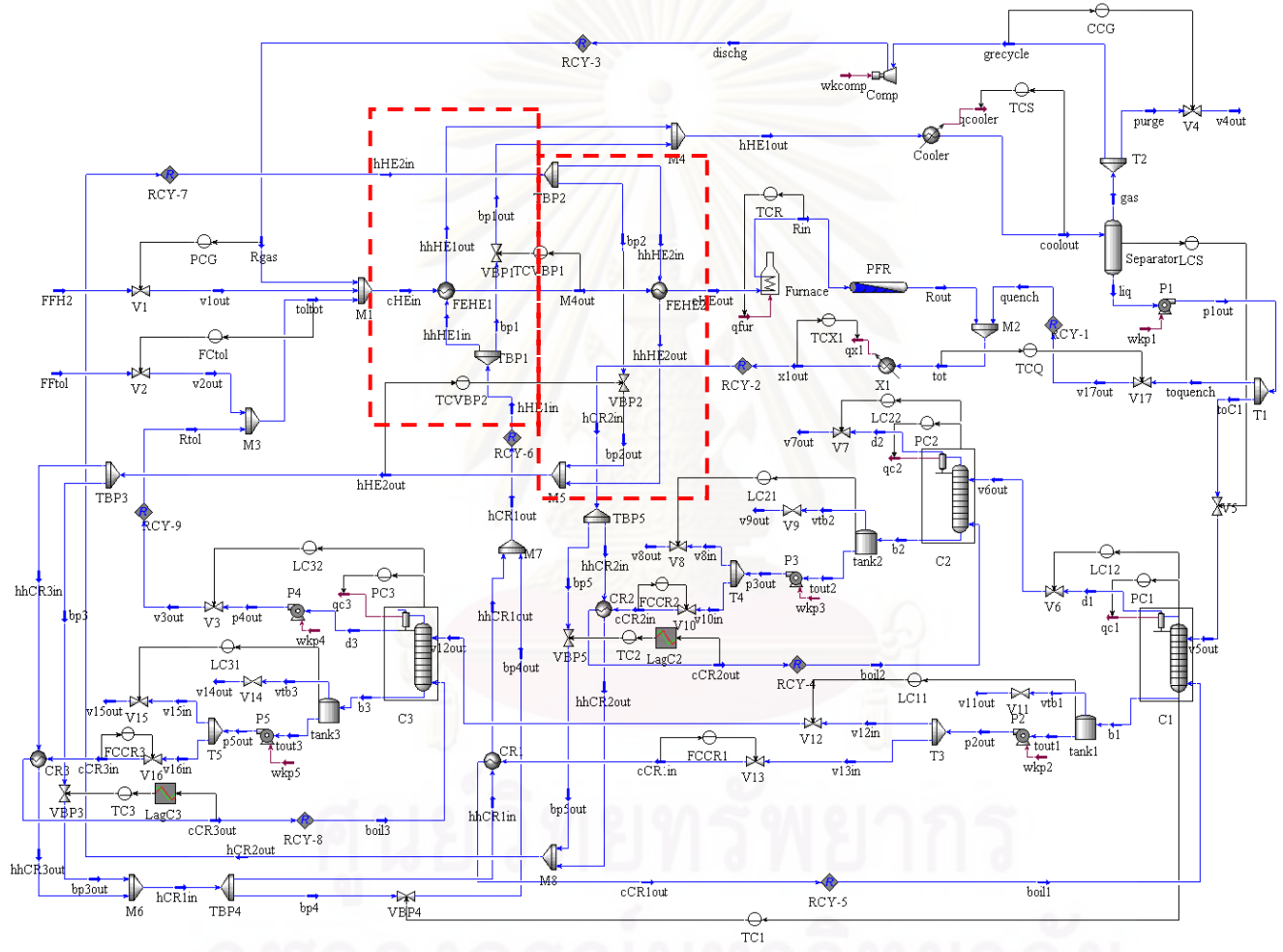

Figure 6.31 Control structure 2 (CS2) of the complex heat-integrated HDA process HIP6.2

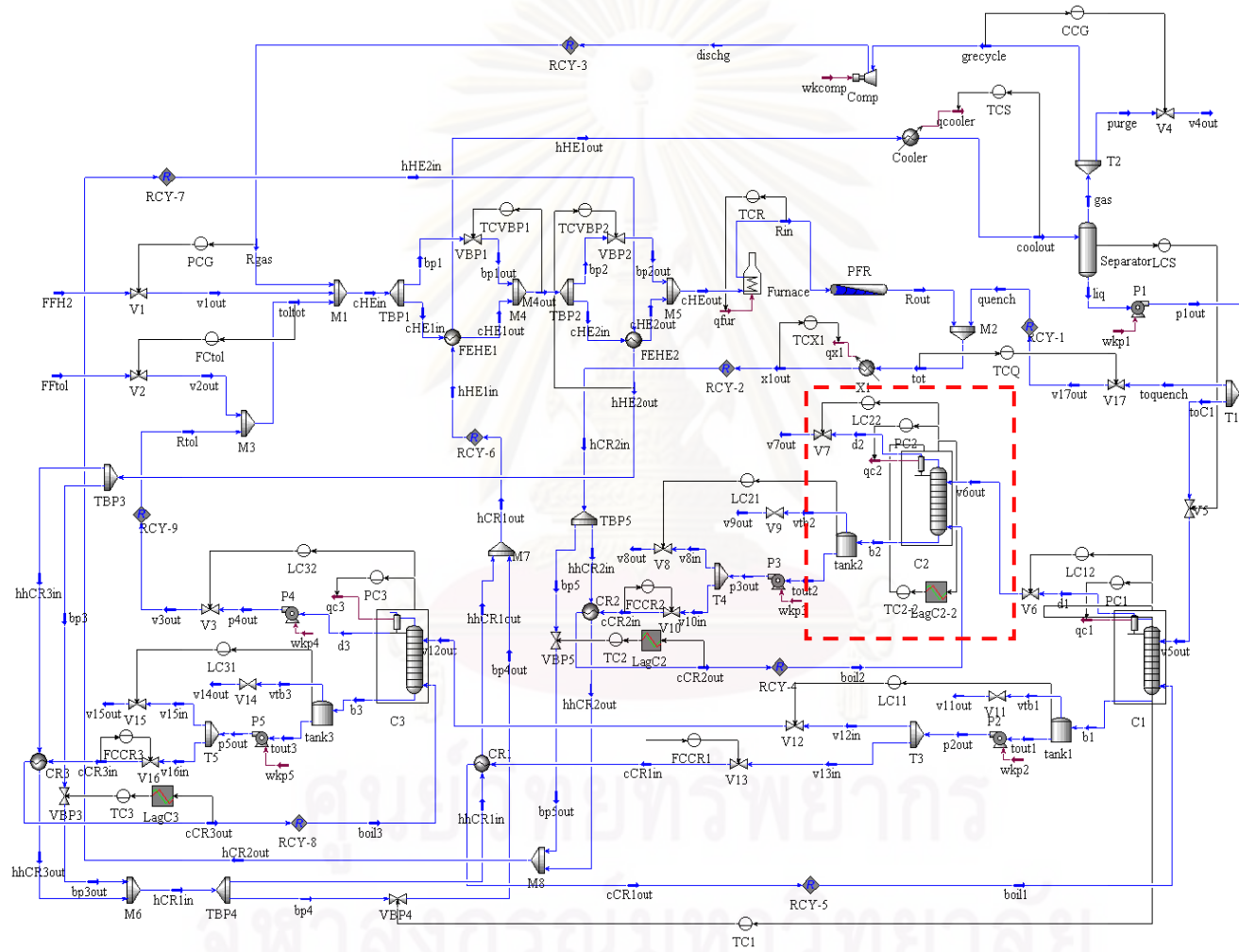

Figure 6.32 Control structure 3 (CS3) of the complex heat-integrated HDA process HIP6.2

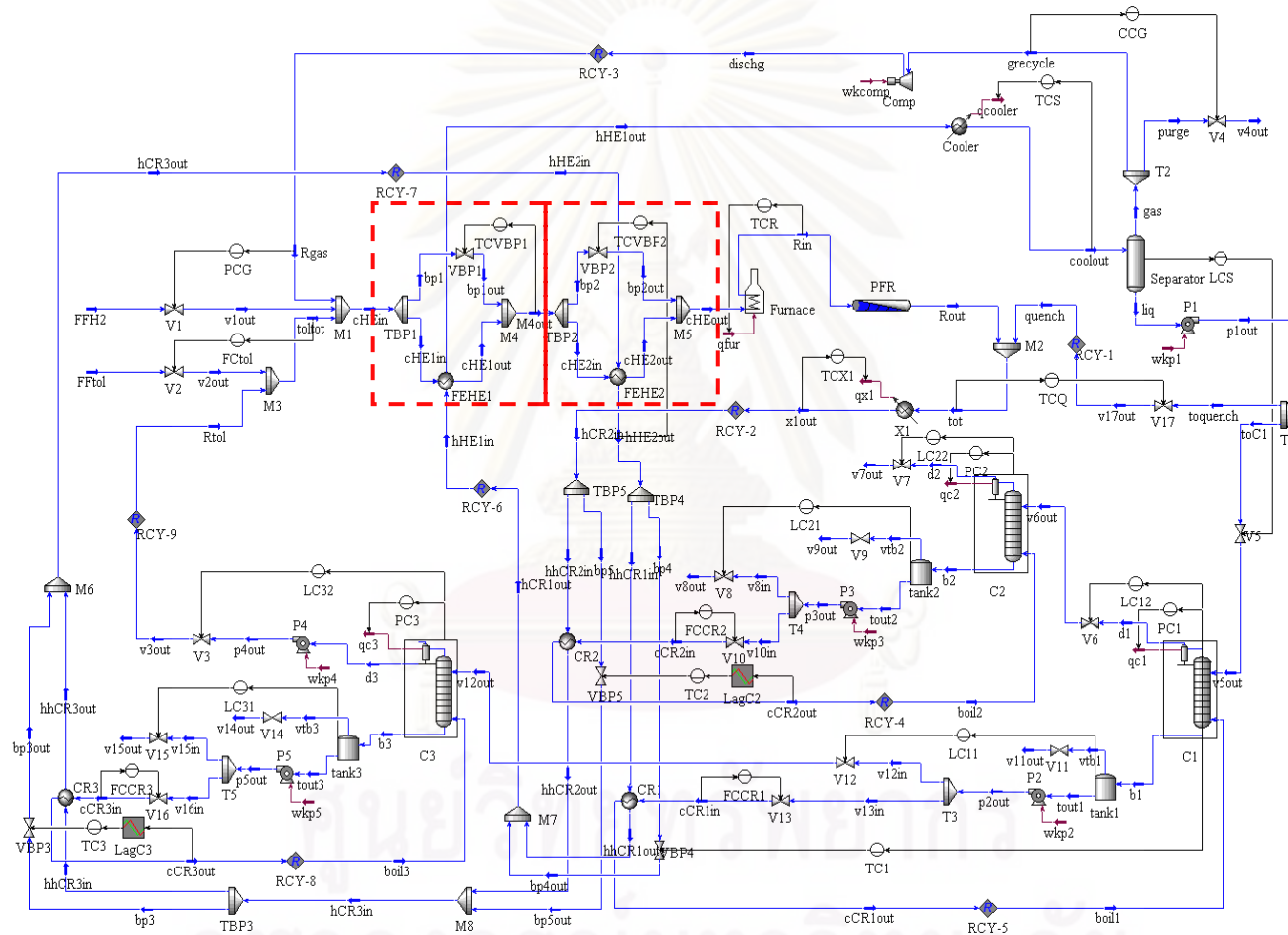

Figure 6.33 Control structure 1 (CS1) of the complex heat-integrated HDA process HIP6.3

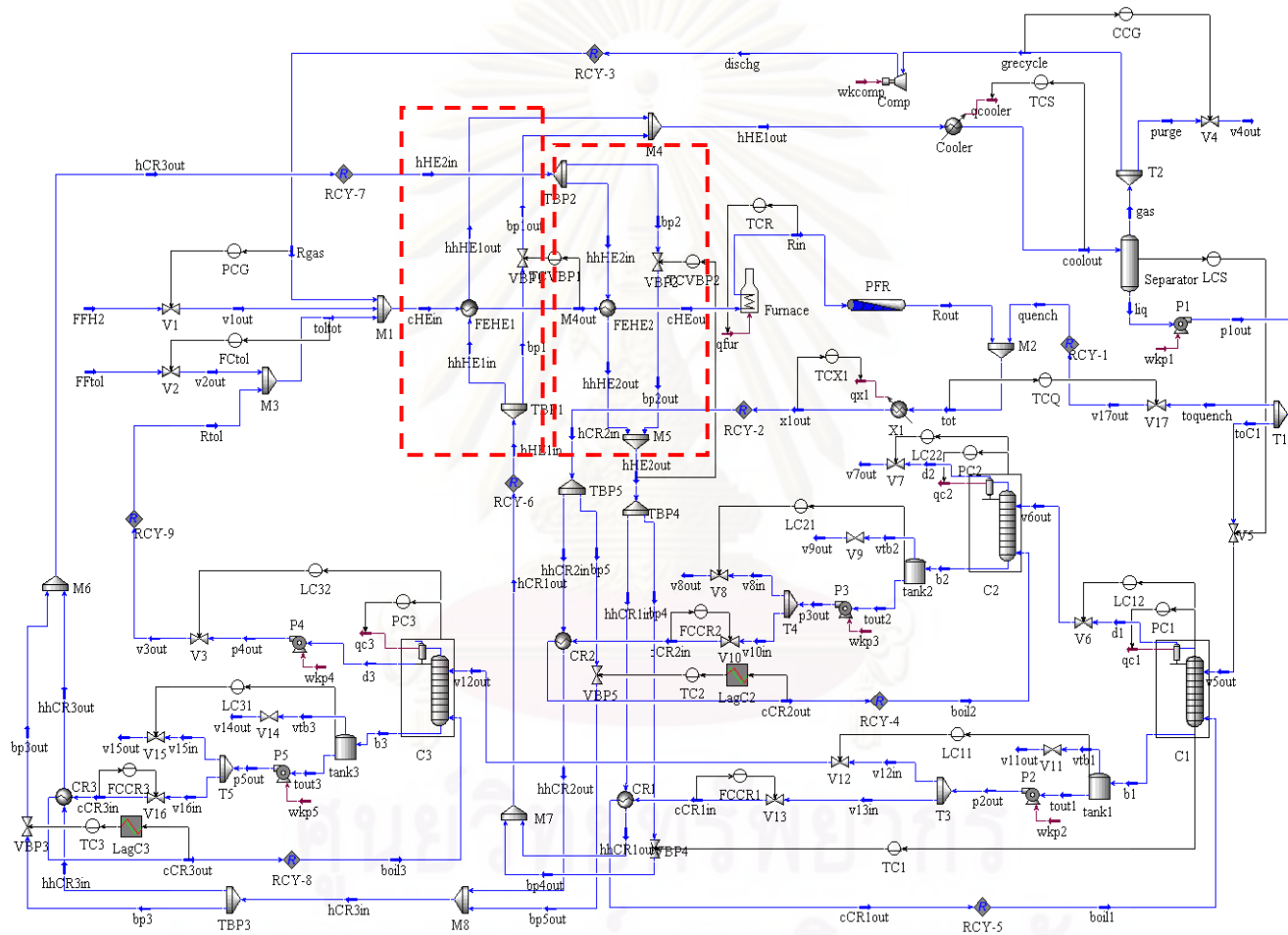

Figure 6.34 Control structure 2 (CS2) of the complex heat-integrated HDA process HIP6.3

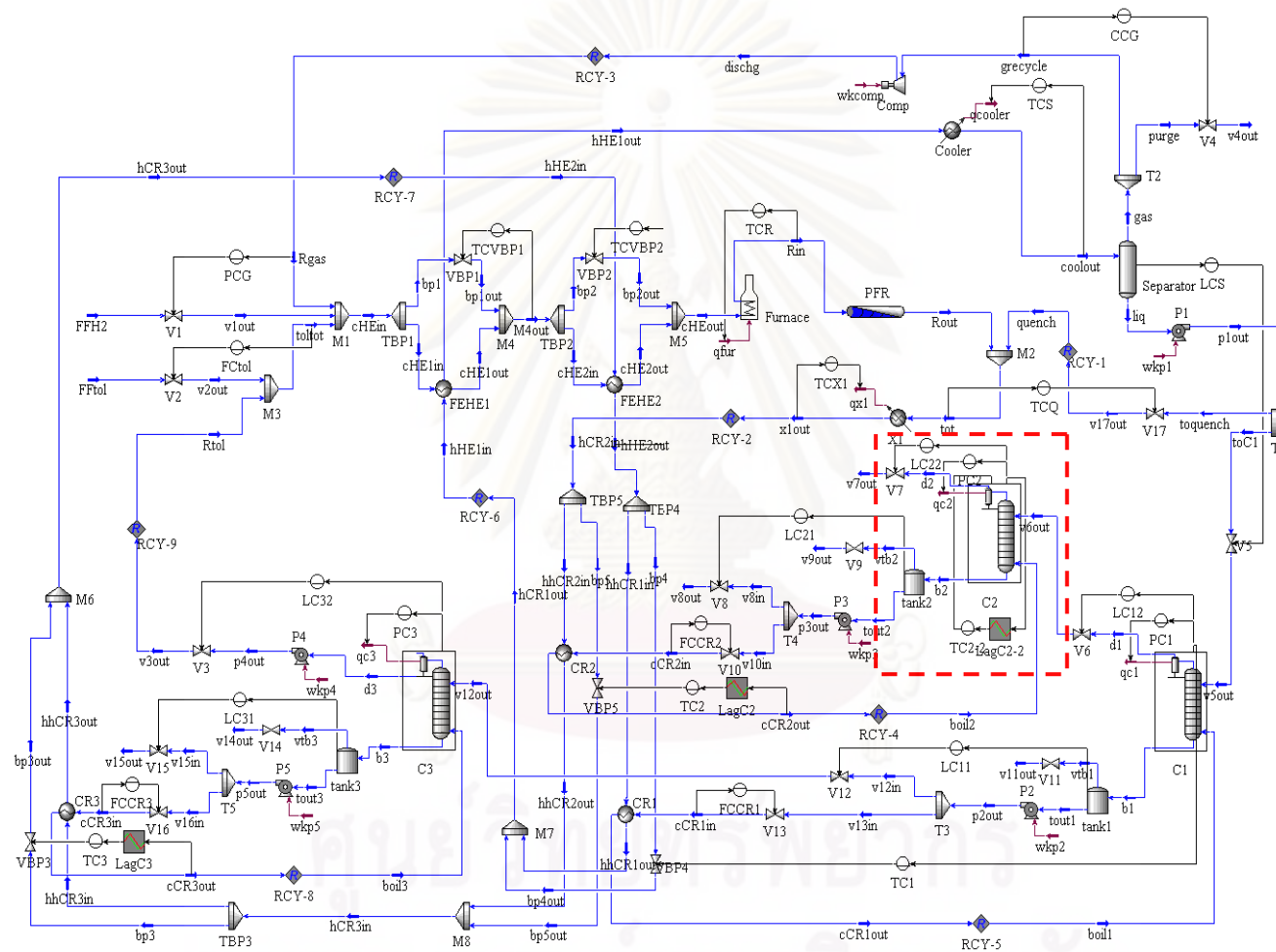

Figure 6.35 Control structure 3 (CS3) of the complex heat-integrated HDA process HIP6.3

6.4 Dynamic Simulation Results

In order to illustrate the dynamic behaviors of new control structures, two kinds of disturbances: thermal and material disturbances are used in evaluation of the plantwide control structures. Three types of disturbance are used to test response of the system: (1) change in the heat load disturbance of cold streams (reactor feed stream), (2) change in the heat load disturbance of hot streams (reactor product stream) and (3) Change in the total toluene feed flowrates. Three disturbance loads are used to evaluate the dynamic performance of the new control structures (CS1, CS2, and CS3) for the typical and heat-integrated plant of HDA process.

Temperature controllers are PIDs which are tuned using relay feedback. Two temperature measurement lags of 0.5 minute are included in the two temperature loops (tray temperature of product column recycle column). Flow and pressure controller are PIs and their parameters are heuristics values. Proportional-only level controllers are used and their parameters are heuristics values. Methane composition is measured and controlled using PI controller. All control valves are half-open at nominal operating condition.

Three control structures (CS1, CS2, and CS3) are implemented on 7 heat-integrated processes which are HIP5.0 and HIP6.0 (typical HDA process) and HIP5.1, HIP5.2, HIP6.1, HIP6.2 and HIP6.3 (heat-integrated HDA process)

6.5 Dynamic Simulation Results of Typical HDA Process

In order to illustrate the dynamic behavior of the control structure in the complex heat-integrated typical HDA process alternative 5 (HIP5.0) and alternative 6 (HIP6.0). Three disturbance loads which are used to evaluate the dynamic performance of the new control structure (CS1, CS2 and CS3) are explained in this section.

6.5.1 Dynamic Simulation Results of Typical HDA Process HIP5.0

Three disturbance loads are used to evaluate the dynamic performance of the new control structure (CS1, CS2 and CS3) for HDA process HIP5.0.

6.5.1.1 Change the Heat Load Disturbance of Cold Streams (Reactor Feed Stream)

The dynamic responses of the control system of the typical HDA process HIP5.0 are shown in Figure 6.36, 6.39 and 6.42. In order to make this disturbance first the fresh toluene feed temperature is decreased from 30 to 20°C at time equals 10 minutes, and the temperature is increased from 20 to 40°C at time equals 100 minutes, then its temperature is returned to its nominal value of 30°C at time equals 200 minutes (see Figure 6.36.a, 6.39.a and 6.42.a).

The three new control structures (CS1, CS2 and CS3) give the same result for shifting the thermal disturbance load in cold steam (reactor feed stream) to heater or cooler as follows. First, the cold inlet temperature of FEHE is decreased and then both the cold and hot outlet temperatures of FEHE decrease suddenly. In order to the hot outlet temperature is decreased to a desired condition, the control action to control the cold outlet temperature of FEHE. As a result, the cold and hot outlet temperature of FEHE rapidly drops to a new steady state value and the cooler duty decreases (see Figure 6.36.l, 6.39.l and 6.42.l). When the cold inlet temperature of FEHE increases, both the cold and hot outlet temperatures of FEHE increase. In order to the hot outlet temperature is increased to a desired condition, the control action to control the cold outlet temperature of FEHE. As a result, the cold and hot outlet temperature of FEHE quickly increases to a new steady state value and the furnace duty decreases (see Figure 6.36.k, 6.39.k and 6.42.k).

As can be see, this disturbance load has a little bit effect to the tray temperature in stabilizer column, product column and recycle columns however the three new control structures can control the tray temperature in three distillation columns slightly well. The reactor inlet temperature, the quench temperature, the separator temperature are slightly well controlled but the dynamic response of CS1 is smoother than CS2 and CS3.

6.5.1.2 Change the Heat Load Disturbance of Hot Streams (Reactor Product Stream)

The dynamic responses of the control system of the typical HDA process HIP5.0 are shown in Figure 6.37, 6.40 and 6.43. This disturbance is made as follows:

first the set point of FEHE-hot-inlet temperature controller (i.e. TCX1) is decreased from 621.1 to 611.1°C at time equals 10 minutes and the temperature is increased from 611.1 to 631.1°C at time equals 100 minutes, then its temperature is returned to its nominal value of 621.1°C at time equals 200 minutes (see Figure 6.37.a, 6.40.a and 6.43.a). As can be seen, this temperature response is very fast, the new steady state is reached quickly

Since the hot outlet temperature of FEHE is controlled to prevent the propagation of the thermal disturbance, both the positive and negative disturbance loads of the hot stream are shifted to the furnace utility. The cooler duty will be decreased in this case. Consider the case when the hot inlet temperature of FEHE increases, this is a desired condition to shift the disturbance load to the cold stream. Therefore, the cooler duty increases to a new steady state value.

For the tray temperatures in the stabilizer, product and recycle columns are slightly well controlled but CS2 is more oscillation than CS1 and CS3. The reactor inlet temperature, the quench temperature, the separator temperature are slightly well controlled but the dynamic response of CS1 is smoother than CS2 and CS3.

6.5.1.3 Change the Total Toluene Feed Flowrates

The dynamic responses of the control system of the typical HDA process HIP5.0 are shown in Figure 6.38, 6.41 and 6.44. This disturbance is made by decreasing toluene flowrates from 172.3 to 162.3 kgmole/h at time equals 10 minutes, and the flowrates is increased from 162.3 to 182.3 kgmole/h at time equals 100 minutes, then its flowrates is returned to its nominal value of 172.3 kgmole/h at time equals 200 minutes (see Figure 6.38.a, 6.41.a and 6.44.a).

The dynamic result can be seen that the drop in total toluene feed flowrates reduces the reaction rate, so fresh feed hydrogen flowrates (see Figure 6.38.h, 6.41.h and 6.44.h), the benzene product flowrates drops (see Figure 6.38.j, 6.41.j and 6.44.j) and the benzene product quality is shown in Figure 6.38.i, 6.41.i and 6.44.i. Consider the case when the total toluene feed flowrates increase and the benzene product flowrates increase because of the reaction rate enlargement. The deviation of benzene product quality from nominal value in CS1, CS2 and CS3 are slightly similar when total toluene feed flowrates change.

As can be see, this disturbance has height effect to tray temperatures in the tray temperatures in the stabilizer, product and recycle columns however all control structure can the tray temperatures in the three columns slightly well.



ศูนย์วิทยทรัพยากร
จุฬาลงกรณ์มหาวิทยาลัย

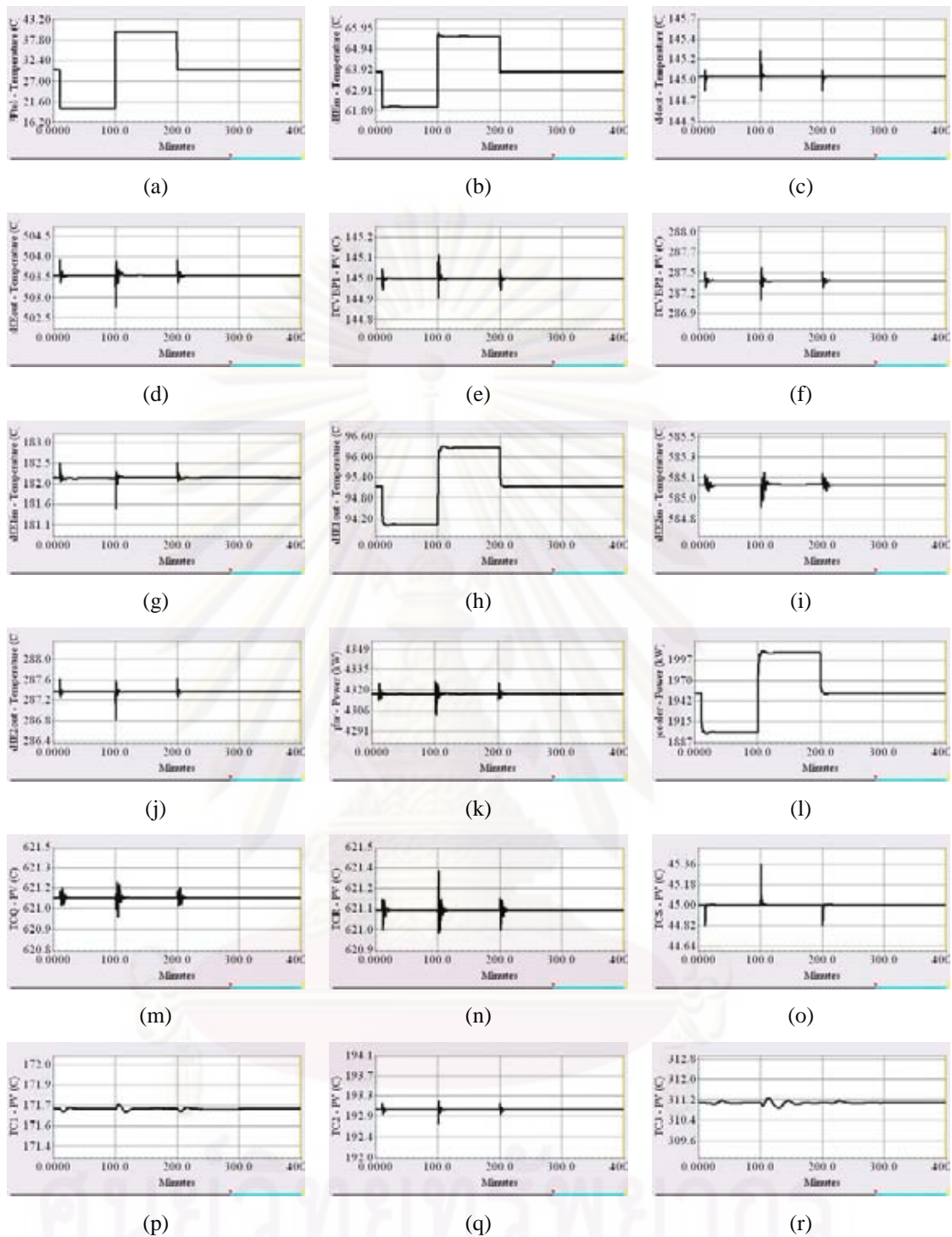

Figure 6.36 Dynamic responses of the typical HDA process HIP5.0 to a change in the heat load disturbance of cold stream (reactor feed stream): CS1, where: (a) fresh feed toluene temperature, (b) FEHE1 cold inlet temperature, (c) FEHE2 cold inlet temperature, (d) FEHE2 cold outlet temperature, (e) FEHE1 bypass stream, (f) FEHE2 bypass stream, (g) FEHE1 hot inlet temperature, (h) FEHE1 hot outlet temperature, (i) FEHE2 hot inlet temperature, (j) FEHE2 hot outlet temperature, (k) furnace duty, (l) cooler duty, (m) quench temperature, (n) reactor inlet temperature, (o) separator temperature, (p) stabilizer column tray temperature, (q) product column tray temperature (r) recycle column tray temperature

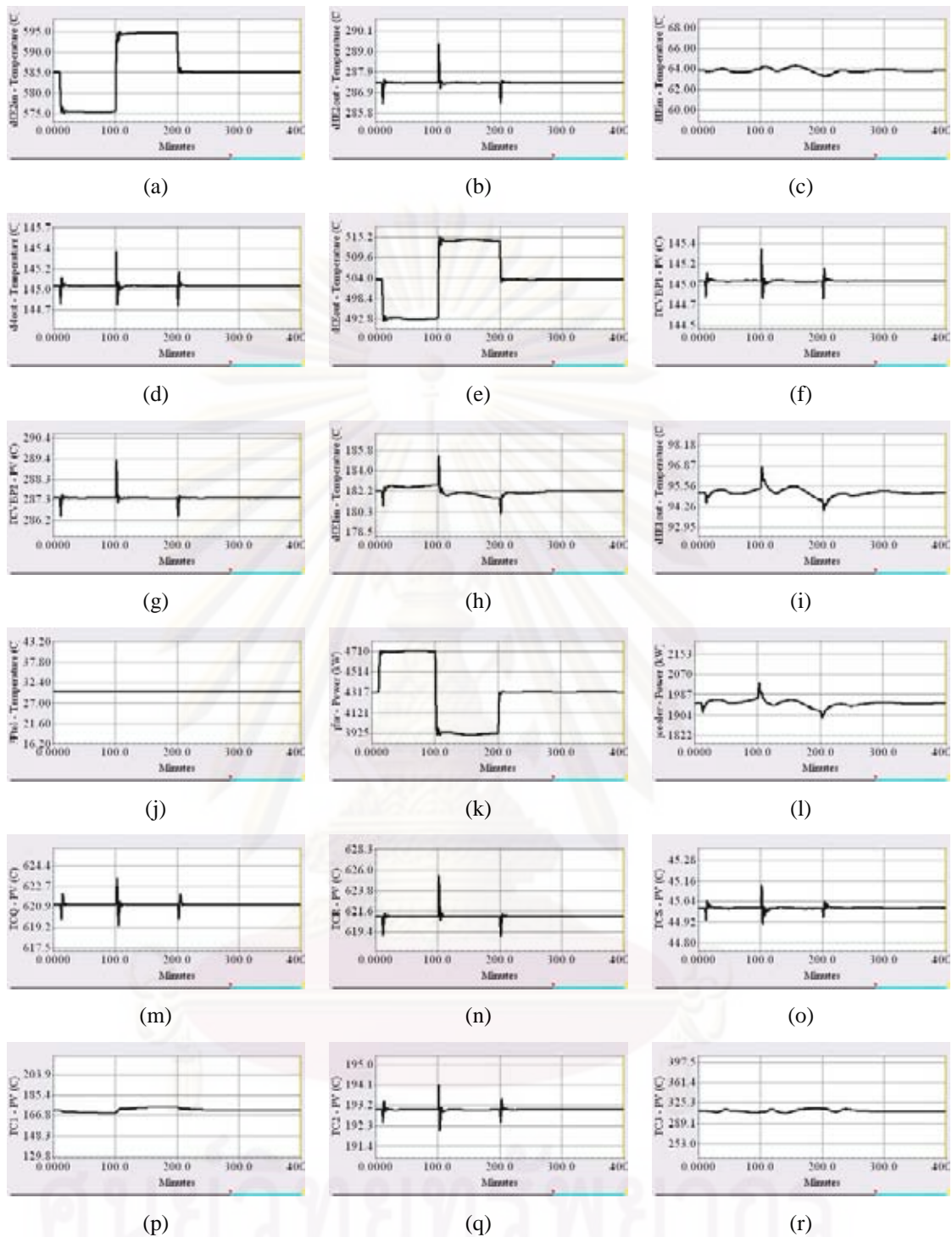

Figure 6.37 Dynamic responses of the typical HDA process HIP5.0 to a change in the heat load disturbance of hot stream (reactor product stream): CS1, where: (a) FEHE2 hot inlet temperature, (b) FEHE2 hot outlet temperature, (c) FEHE1 cold inlet temperature, (d) FEHE2 cold inlet temperature, (e) FEHE2 cold outlet temperature, (f) FEHE1 bypass stream, (g) FEHE2 bypass stream, (h) FEHE1 hot inlet temperature, (i) FEHE1 hot outlet temperature, (j) fresh feed toluene temperature (k) furnace duty, (l) cooler duty, (m) quench temperature, (n) reactor inlet temperature, (o) separator temperature, (p) stabilizer column tray temperature, (q) product column tray temperature (r) recycle column tray temperature

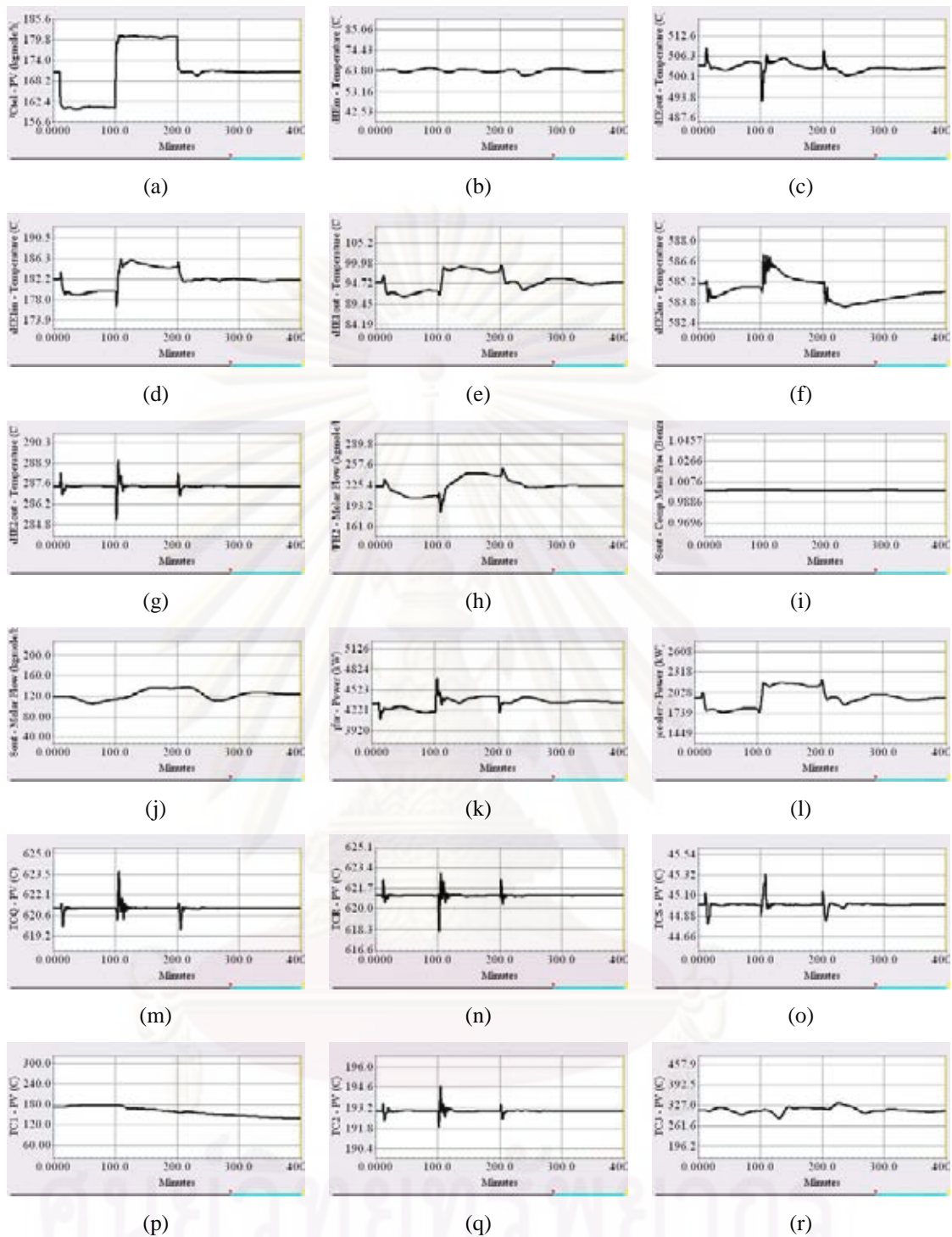

Figure 6.38 Dynamic responses of the typical HDA process HIP5.0 to a change in the total toluene feed flowrates: CS1, where: (a) total toluene feed flowrates, (b) FEHE1 cold inlet temperature, (c) FEHE2 cold outlet temperature, (d) FEHE1 hot inlet temperature, (e) FEHE1 hot outlet temperature, (f) FEHE2 hot inlet temperature, (g) FEHE2 hot outlet temperature, (h) fresh feed hydrogen flowrates, (i) benzene purity, (j) benzene flowrate (k) furnace duty, (l) cooler duty, (m) quench temperature, (n) reactor inlet temperature, (o) separator temperature, (p) stabilizer column tray temperature, (q) product column tray temperature (r) recycle column tray temperature

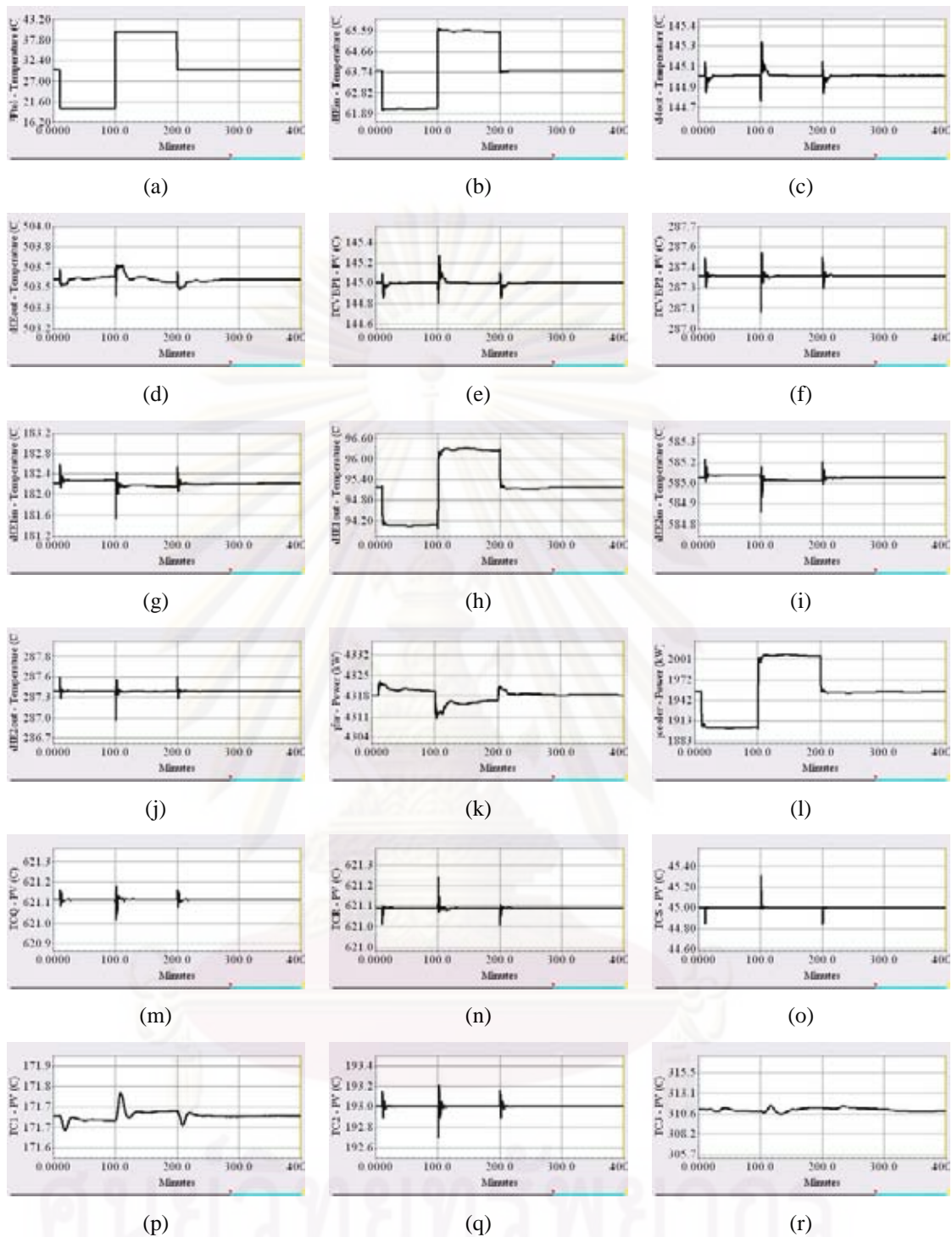

Figure 6.39 Dynamic responses of the typical HDA process HIP5.0 to a change in the heat load disturbance of cold stream (reactor feed stream): CS2, where: (a) fresh feed toluene temperature, (b) FEHE1 cold inlet temperature, (c) FEHE2 cold inlet temperature, (d) FEHE2 cold outlet temperature, (e) FEHE1 bypass stream, (f) FEHE2 bypass stream, (g) FEHE1 hot inlet temperature, (h) FEHE1 hot outlet temperature, (i) FEHE2 hot inlet temperature, (j) FEHE2 hot outlet temperature, (k) furnace duty, (l) cooler duty, (m) quench temperature, (n) reactor inlet temperature, (o) separator temperature, (p) stabilizer column tray temperature, (q) product column tray temperature (r) recycle column tray temperature

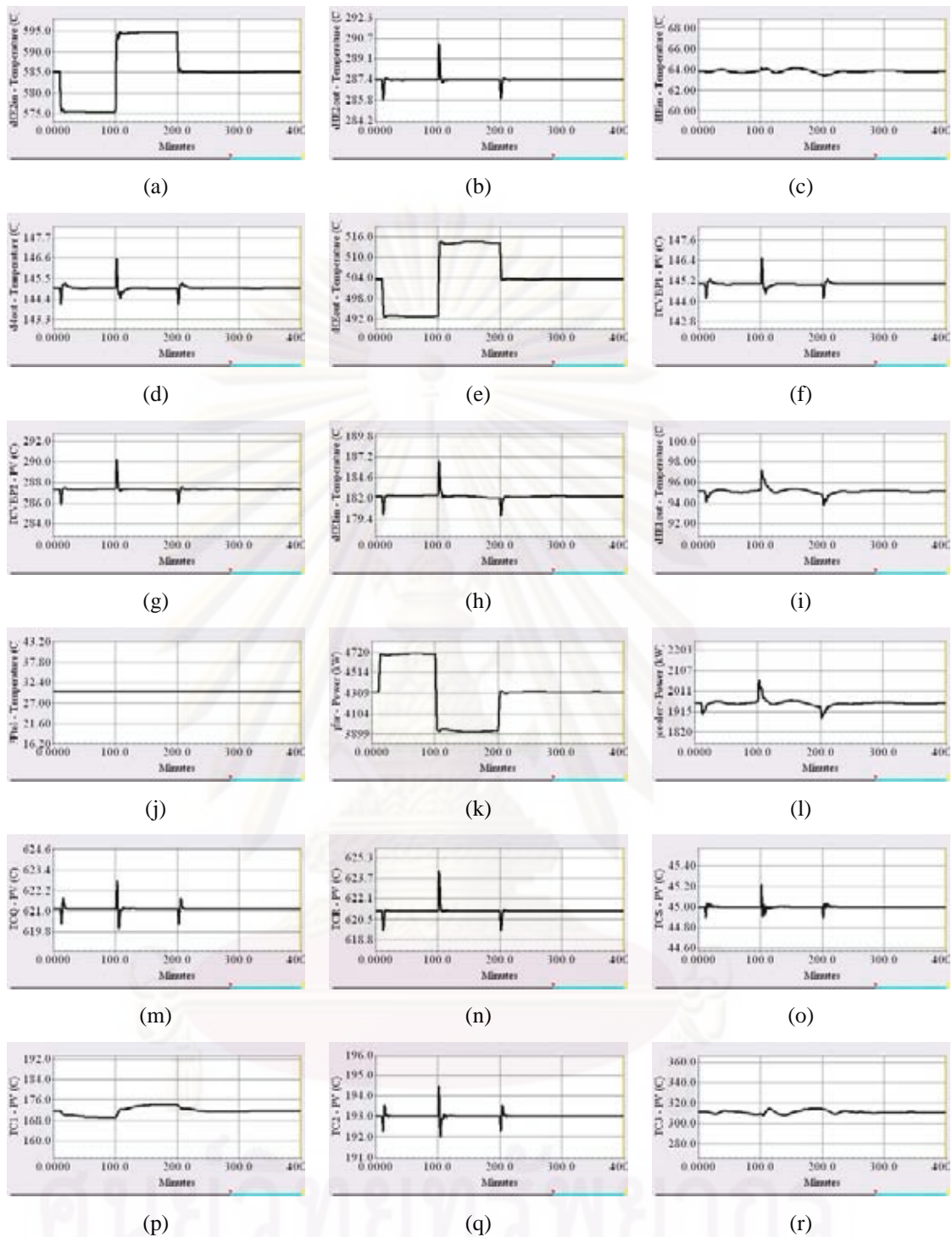

Figure 6.40 Dynamic responses of the typical HDA process HIP5.0 to a change in the heat load disturbance of hot stream (reactor product stream): CS₂, where: (a) FEHE2 hot inlet temperature, (b) FEHE2 hot outlet temperature, (c) FEHE1 cold inlet temperature, (d) FEHE2 cold inlet temperature, (e) FEHE2 cold outlet temperature, (f) FEHE1 bypass stream, (g) FEHE2 bypass stream, (h) FEHE1 hot inlet temperature, (i) FEHE1 hot outlet temperature, (j) fresh feed toluene temperature (k) furnace duty, (l) cooler duty, (m) quench temperature, (n) reactor inlet temperature, (o) separator temperature, (p) stabilizer column tray temperature, (q) product column tray temperature (r) recycle column tray temperature

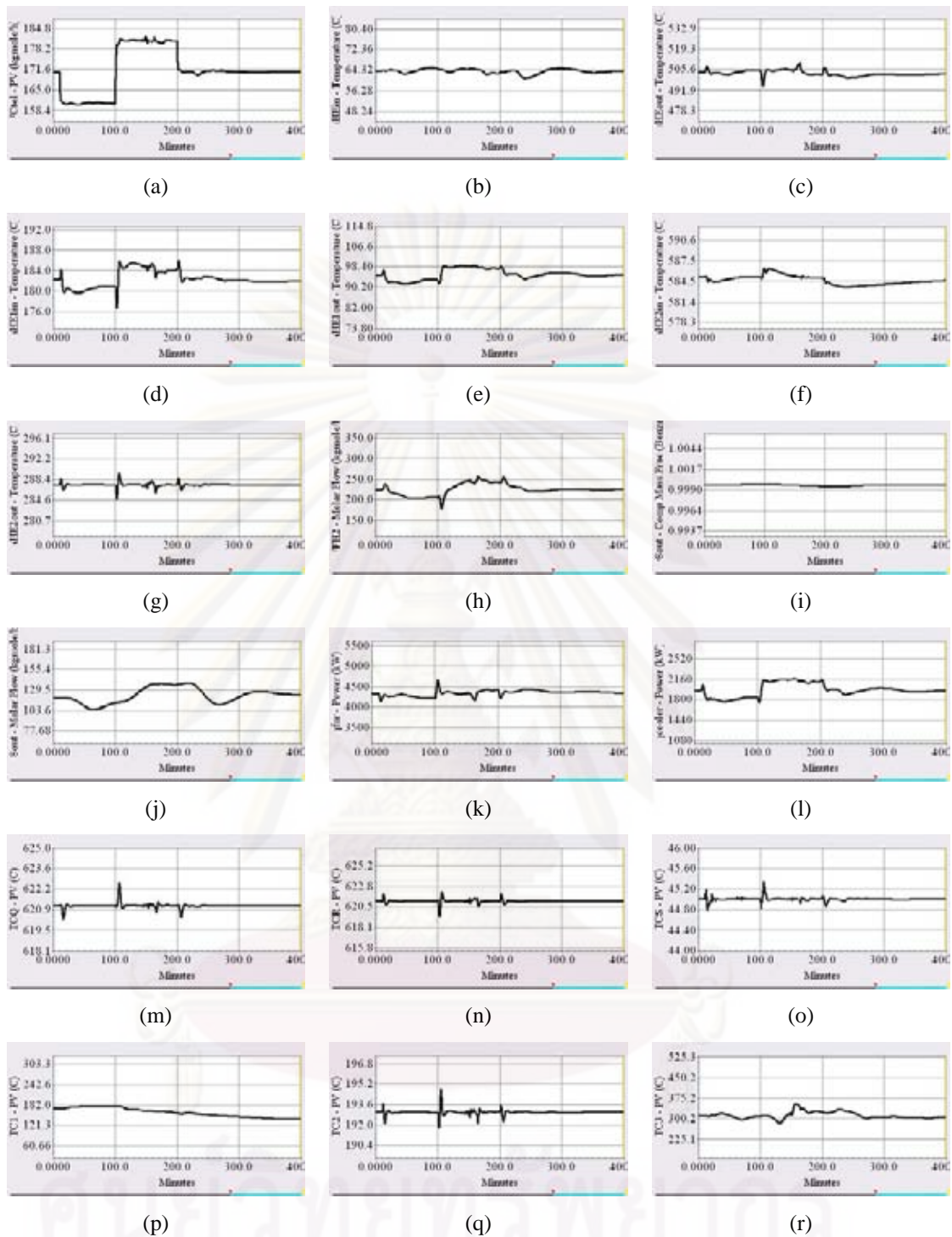

Figure 6.41 Dynamic responses of the typical HDA process HIP5.0 to a change in the total toluene feed flowrates: CS₂, where: (a) total toluene feed flowrates, (b) FEHE1 cold inlet temperature, (c) FEHE2 cold outlet temperature, (d) FEHE1 hot inlet temperature, (e) FEHE1 hot outlet temperature, (f) FEHE2 hot inlet temperature, (g) FEHE2 hot outlet temperature, (h) fresh feed hydrogen flowrates, (i) benzene purity, (j) benzene flowrate (k) furnace duty, (l) cooler duty, (m) quench temperature, (n) reactor inlet temperature, (o) separator temperature, (p) stabilizer column tray temperature, (q) product column tray temperature (r) recycle column tray temperature

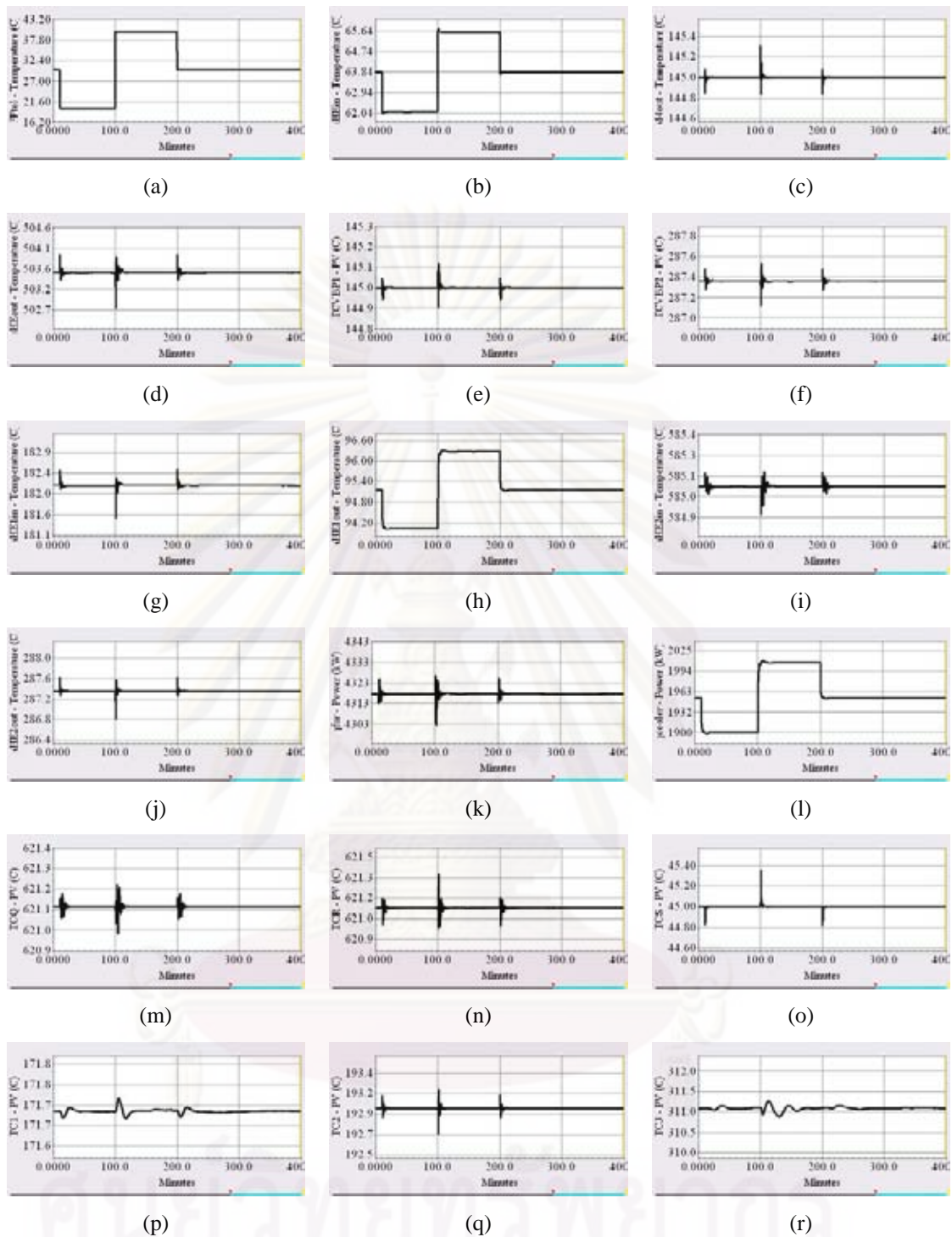

Figure 6.42 Dynamic responses of the typical HDA process HIP5.0 to a change in the heat load disturbance of cold stream (reactor feed stream): CS3, where: (a) fresh feed toluene temperature, (b) FEHE1 cold inlet temperature, (c) FEHE2 cold inlet temperature, (d) FEHE2 cold outlet temperature, (e) FEHE1 bypass stream, (f) FEHE2 bypass stream, (g) FEHE1 hot inlet temperature, (h) FEHE1 hot outlet temperature, (i) FEHE2 hot inlet temperature, (j) FEHE2 hot outlet temperature, (k) furnace duty, (l) cooler duty, (m) quench temperature, (n) reactor inlet temperature, (o) separator temperature, (p) stabilizer column tray temperature, (q) product column tray temperature (r) recycle column tray temperature

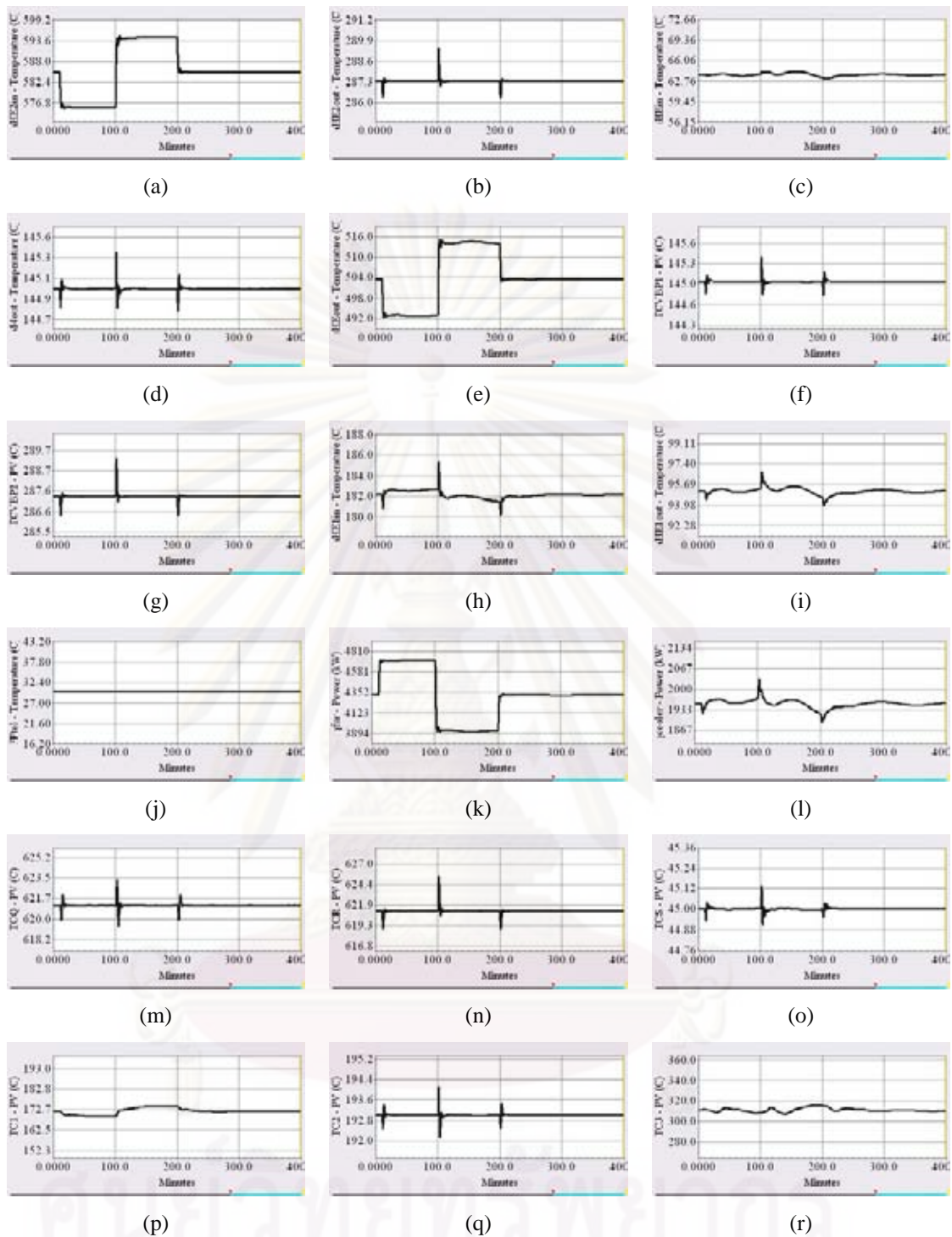

Figure 6.43 Dynamic responses of the typical HDA process HIP5.0 to a change in the heat load disturbance of hot stream (reactor product stream): CS3, where: (a) FEHE2 hot inlet temperature, (b) FEHE2 hot outlet temperature, (c) FEHE1 cold inlet temperature, (d) FEHE2 cold inlet temperature, (e) FEHE2 cold outlet temperature, (f) FEHE1 bypass stream, (g) FEHE2 bypass stream, (h) FEHE1 hot inlet temperature, (i) FEHE1 hot outlet temperature, (j) fresh feed toluene temperature (k) furnace duty, (l) cooler duty, (m) quench temperature, (n) reactor inlet temperature, (o) separator temperature, (p) stabilizer column tray temperature, (q) product column tray temperature (r) recycle column tray temperature

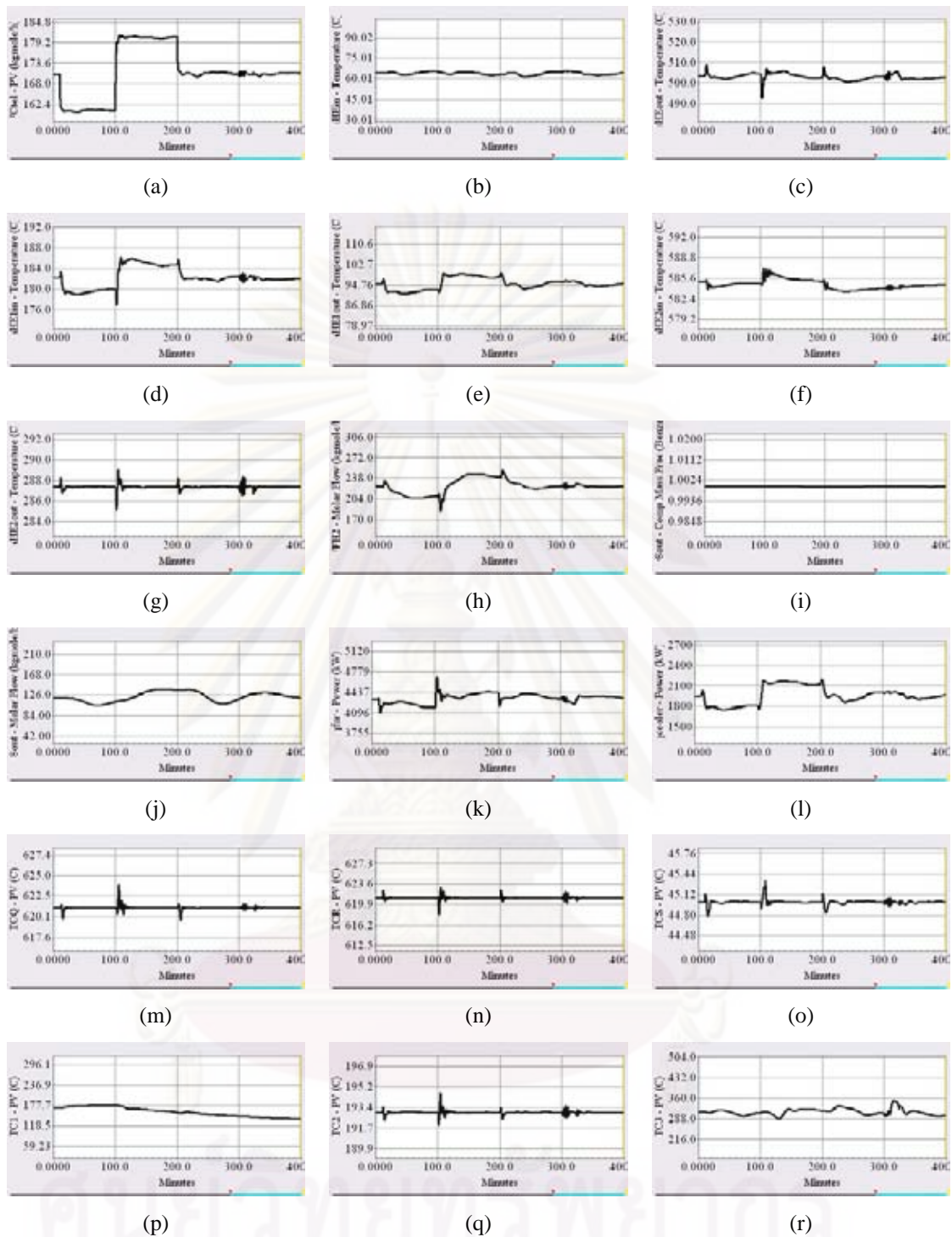

Figure 6.44 Dynamic responses of the typical HDA process HIP5.0 to a change in the total toluene feed flowrates: CS3, where: (a) total toluene feed flowrates, (b) FEHE1 cold inlet temperature, (c) FEHE2 cold outlet temperature, (d) FEHE1 hot inlet temperature, (e) FEHE1 hot outlet temperature, (f) FEHE2 hot inlet temperature, (g) FEHE2 hot outlet temperature, (h) fresh feed hydrogen flowrates, (i) benzene purity, (j) benzene flowrate (k) furnace duty, (l) cooler duty, (m) quench temperature, (n) reactor inlet temperature, (o) separator temperature, (p) stabilizer column tray temperature, (q) product column tray temperature (r) recycle column tray temperature

6.5.2 Dynamic Simulation Results of Typical HDA Process HIP6.0

Three disturbance loads are used to evaluate the dynamic performance of the new control structure (CS1, CS2 and CS3) for HDA process HIP6.0.

6.5.2.1 Change the Heat Load Disturbance of Cold Streams (Reactor Feed Stream)

The dynamic responses of the control system of the typical HDA process HIP6.0 are shown in Figure 6.45, 6.48 and 6.51. In order to make this disturbance first the fresh toluene feed temperature is decreased from 30 to 20°C at time equals 10 minutes, and the temperature is increased from 20 to 40°C at time equals 100 minutes, then its temperature is returned to its nominal value of 30°C at time equals 200 minutes (see Figure 6.45.a, 6.48.a and 6.51.a).

The three new control structures (CS1, CS2 and CS3) give the same result for shifting the thermal disturbance load in cold steam (reactor feed stream) to heater or cooler as follows. First, the cold inlet temperature of FEHE is decreased and then both the cold and hot outlet temperatures of FEHE decrease suddenly. In order to the hot outlet temperature is decreased to a desired condition, the control action to control the cold outlet temperature of FEHE. As a result, the cold and hot outlet temperature of FEHE rapidly drops to a new steady state value and the cooler duty decreases (see Figure 6.45.l, 6.48.l and 6.51.l). When the cold inlet temperature of FEHE increases, both the cold and hot outlet temperatures of FEHE increase. In order to the hot outlet temperature is increased to a desired condition, the control action to control the cold outlet temperature of FEHE. As a result, the cold and hot outlet temperature of FEHE quickly increases to a new steady state value and the furnace duty decreases (see Figure 6.45.k, 6.48.k and 6.51.k).

As can be see, this disturbance load has a little bit effect to the tray temperature in stabilizer column, product column and recycle columns however the three new control structures can control the tray temperature in three distillation columns slightly well. The reactor inlet temperature, the quench temperature, the separator temperature are slightly well controlled but the dynamic response of CS1 is smoother than CS2 and CS3.

6.5.2.2 Change the Heat Load Disturbance of Hot Streams (Reactor Product Stream)

The dynamic responses of the control system of the typical HDA process HIP6.0 are shown in Figure 6.46, 6.49 and 6.52. This disturbance is made as follows: first the set point of FEHE-hot-inlet temperature controller (i.e. TCX1) is decreased from 621.1 to 611.1°C at time equals 10 minutes and the temperature is increased from 611.1 to 631.1°C at time equals 100 minutes, then its temperature is returned to its nominal value of 621.1°C at time equals 200 minutes (see Figure 6.46.a, 6.49.a and 6.52.a). As can be seen, this temperature response is very fast, the new steady state is reached quickly

Since the hot outlet temperature of FEHE is controlled to prevent the propagation of the thermal disturbance, both the positive and negative disturbance loads of the hot stream are shifted to the furnace utility. The cooler duty will be decreased in this case. Consider the case when the hot inlet temperature of FEHE increases, this is a desired condition to shift the disturbance load to the cold stream. Therefore, the cooler duty increases to a new steady state value.

For the tray temperatures in the stabilizer, product and recycle columns are slightly well controlled but CS2 is more oscillation than CS1 and CS3. The reactor inlet temperature, the quench temperature, the separator temperature are slightly well controlled but the dynamic response of CS1 is smoother than CS2 and CS3.

6.5.2.3 Change the Total Toluene Feed Flowrates

The dynamic responses of the control system of the typical HDA process HIP6.0 are shown in Figure 6.47, 6.50 and 6.53. This disturbance is made by decreasing toluene flowrates from 172.3 to 162.3 kgmole/h at time equals 10 minutes, and the flowrates is increased from 162.3 to 182.3 kgmole/h at time equals 100 minutes, then its flowrates is returned to its nominal value of 172.3 kgmole/h at time equals 200 minutes (see Figure 6.47.a, 6.50.a and 6.53.a).

The dynamic result can be seen that the drop in total toluene feed flowrates reduces the reaction rate, so fresh feed hydrogen flowrates (see Figure 6.47.h, 6.50.h and 6.53.h), the benzene product flowrates drops (see Figure 6.47.j, 6.50.j and 6.53.j)

and the benzene product quality is shown in Figure 6.47.i, 6.50.i and 6.53.i. Consider the case when the total toluene feed flowrates increase and the benzene product flowrates increase because of the reaction rate enlargement. The deviation of benzene product quality from nominal value in CS1, CS2 and CS3 are slightly similar when total toluene feed flowrates change.

As can be see, this disturbance has height effect to tray temperatures in the tray temperatures in the stabilizer, product and recycle columns however all control structure can the tray temperatures in the three columns slightly well.

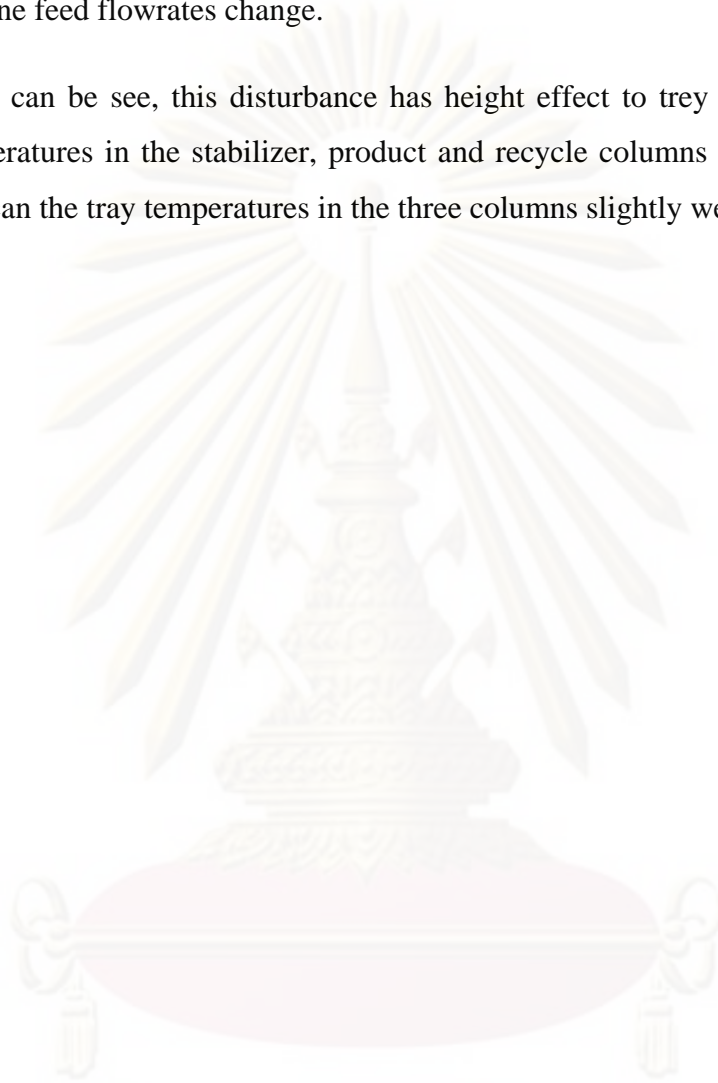

ศูนย์วิทยทรัพยากร
จุฬาลงกรณ์มหาวิทยาลัย

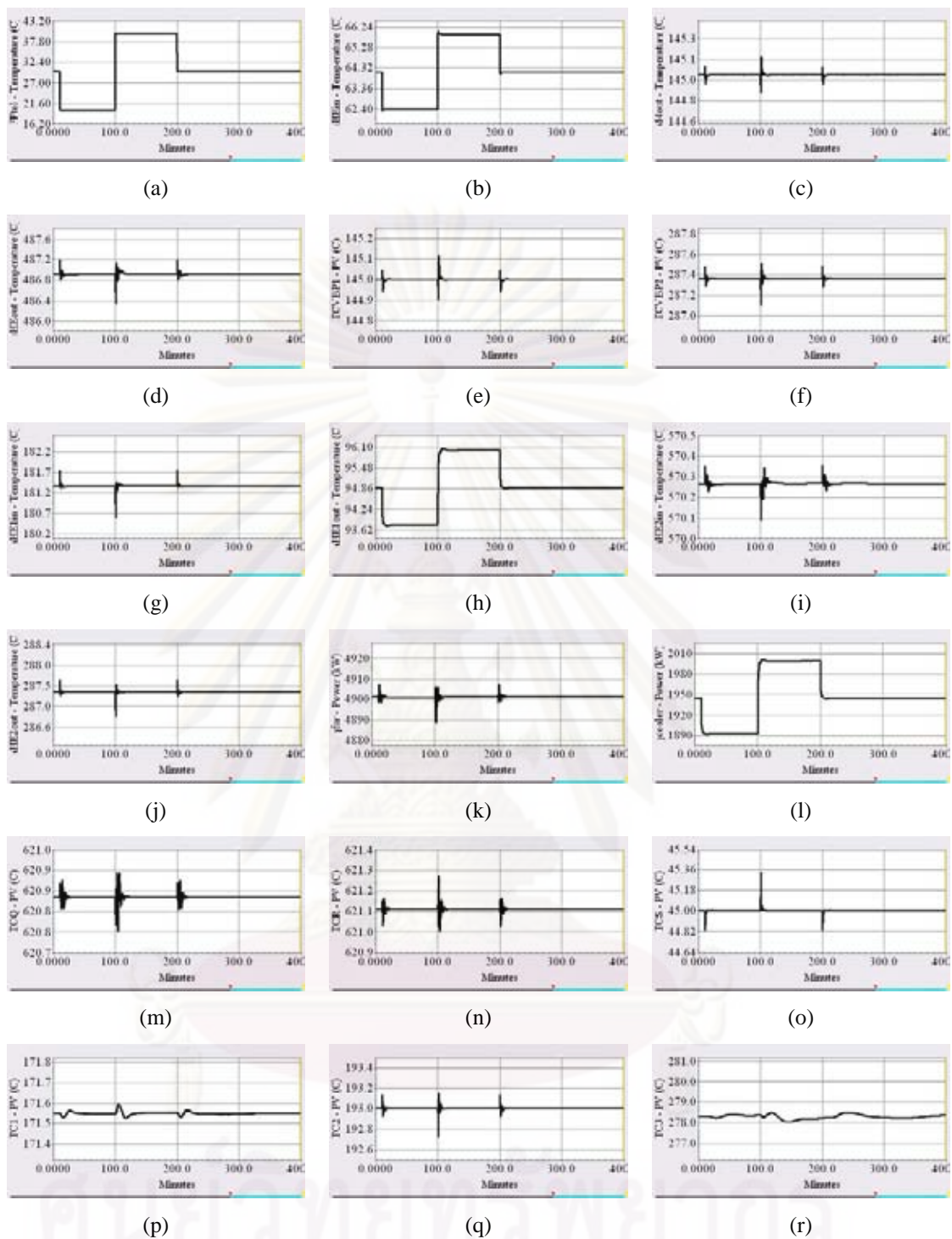

Figure 6.45 Dynamic responses of the typical HDA process HIP6.0 to a change in the heat load disturbance of cold stream (reactor feed stream): CS1, where: (a) fresh feed toluene temperature, (b) FEHE1 cold inlet temperature, (c) FEHE2 cold inlet temperature, (d) FEHE2 cold outlet temperature, (e) FEHE1 bypass stream, (f) FEHE2 bypass stream, (g) FEHE1 hot inlet temperature, (h) FEHE1 hot outlet temperature, (i) FEHE2 hot inlet temperature, (j) FEHE2 hot outlet temperature, (k) furnace duty, (l) cooler duty, (m) quench temperature, (n) reactor inlet temperature, (o) separator temperature, (p) stabilizer column tray temperature, (q) product column tray temperature (r) recycle column tray temperature

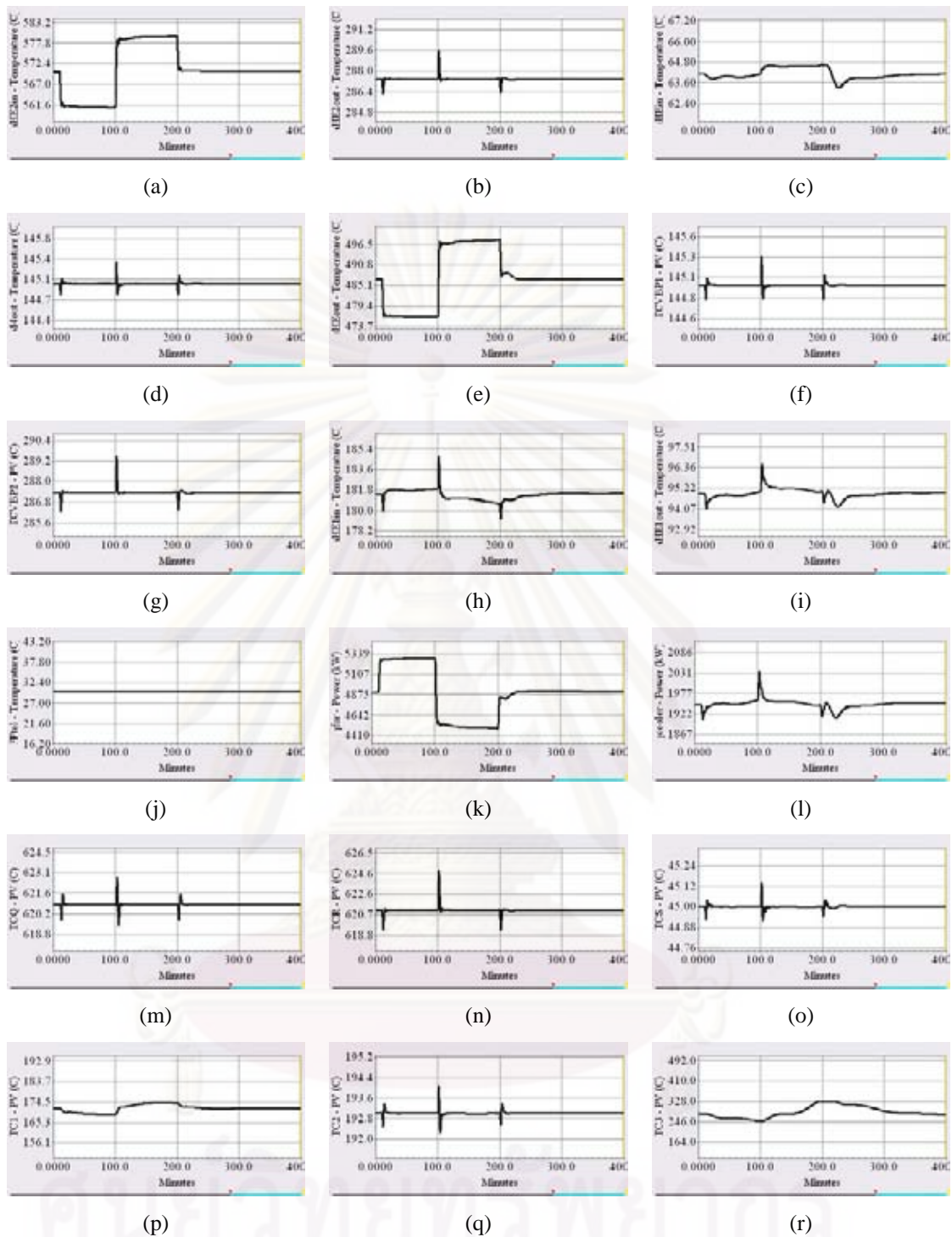

Figure 6.46 Dynamic responses of the typical HDA process HIP6.0 to a change in the heat load disturbance of hot stream (reactor product stream): CS1, where: (a) FEHE2 hot inlet temperature, (b) FEHE2 hot outlet temperature, (c) FEHE1 cold inlet temperature, (d) FEHE2 cold inlet temperature, (e) FEHE2 cold outlet temperature, (f) FEHE1 bypass stream, (g) FEHE2 bypass stream, (h) FEHE1 hot inlet temperature, (i) FEHE1 hot outlet temperature, (j) fresh feed toluene temperature (k) furnace duty, (l) cooler duty, (m) quench temperature, (n) reactor inlet temperature, (o) separator temperature, (p) stabilizer column tray temperature, (q) product column tray temperature (r) recycle column tray temperature

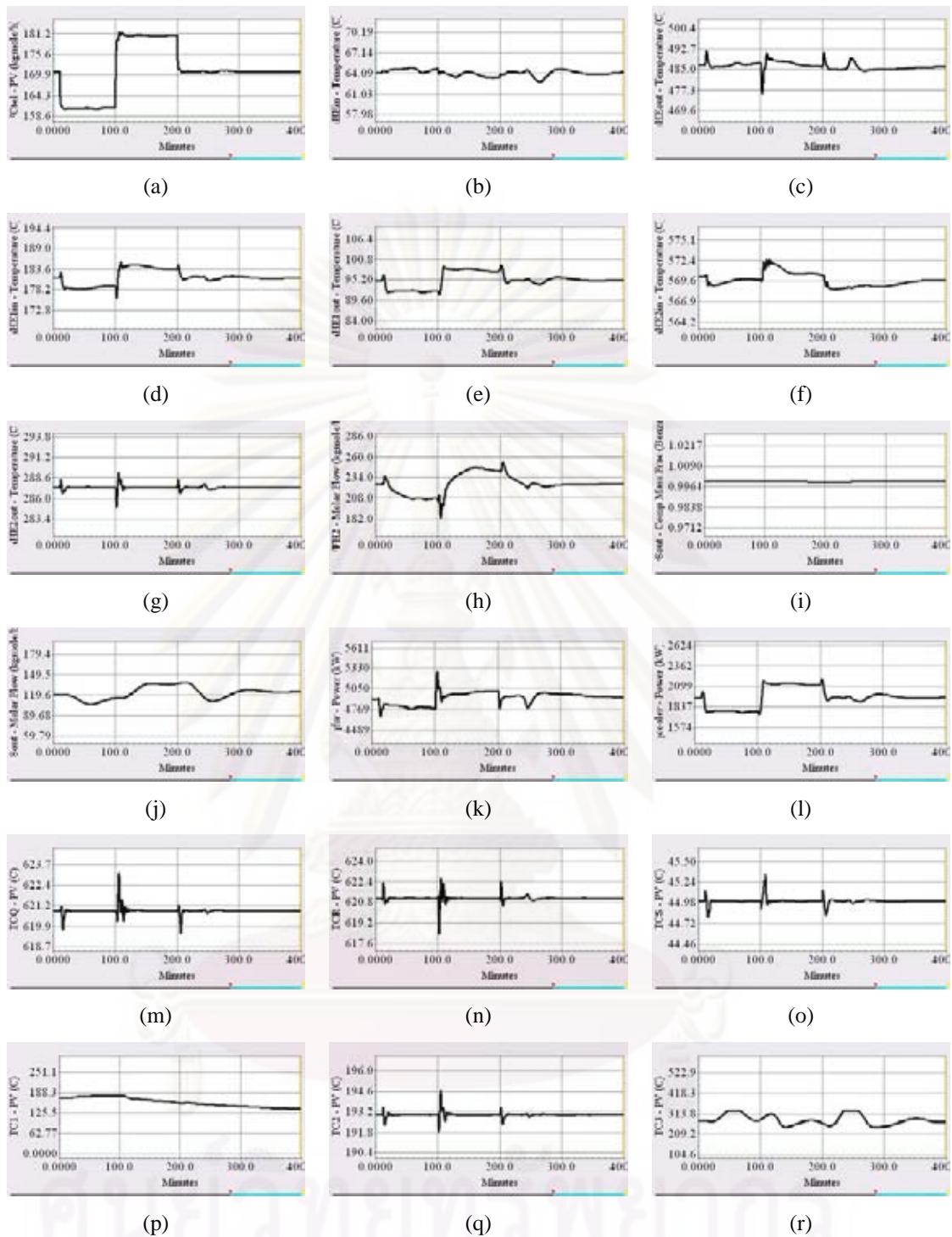

Figure 6.47 Dynamic responses of the typical HDA process HIP6.0 to a change in the total toluene feed flowrates: CS1, where: (a) total toluene feed flowrates, (b) FEHE1 cold inlet temperature, (c) FEHE2 cold outlet temperature, (d) FEHE1 hot inlet temperature, (e) FEHE1 hot outlet temperature, (f) FEHE2 hot inlet temperature, (g) FEHE2 hot outlet temperature, (h) fresh feed hydrogen flowrates, (i) benzene purity, (j) benzene flowrate (k) furnace duty, (l) cooler duty, (m) quench temperature, (n) reactor inlet temperature, (o) separator temperature, (p) stabilizer column tray temperature, (q) product column tray temperature (r) recycle column tray temperature

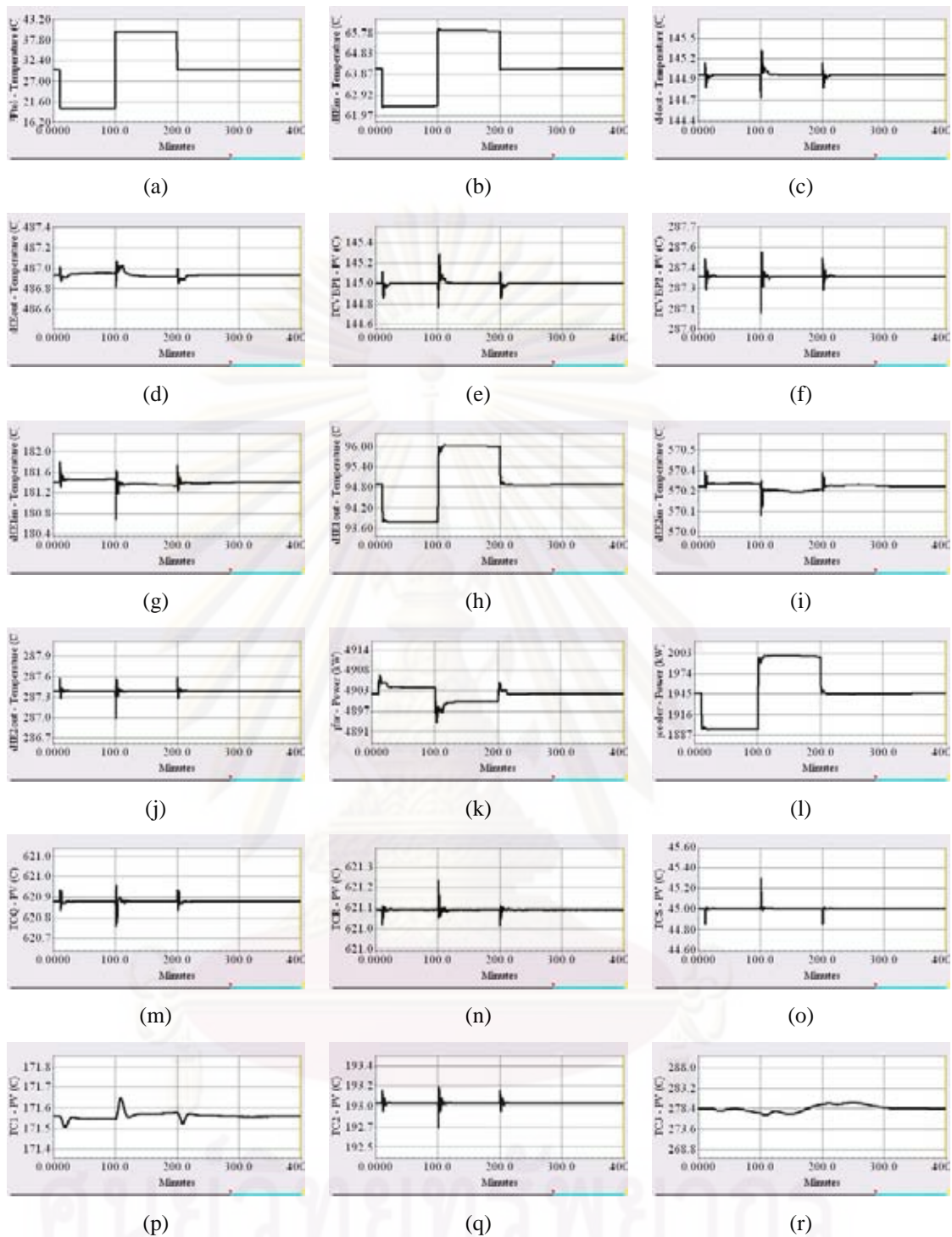

Figure 6.48 Dynamic responses of the typical HDA process HIP6.0 to a change in the heat load disturbance of cold stream (reactor feed stream): CS2, where: (a) fresh feed toluene temperature, (b) FEHE1 cold inlet temperature, (c) FEHE2 cold inlet temperature, (d) FEHE2 cold outlet temperature, (e) FEHE1 bypass stream, (f) FEHE2 bypass stream, (g) FEHE1 hot inlet temperature, (h) FEHE1 hot outlet temperature, (i) FEHE2 hot inlet temperature, (j) FEHE2 hot outlet temperature, (k) furnace duty, (l) cooler duty, (m) quench temperature, (n) reactor inlet temperature, (o) separator temperature, (p) stabilizer column tray temperature, (q) product column tray temperature (r) recycle column tray temperature

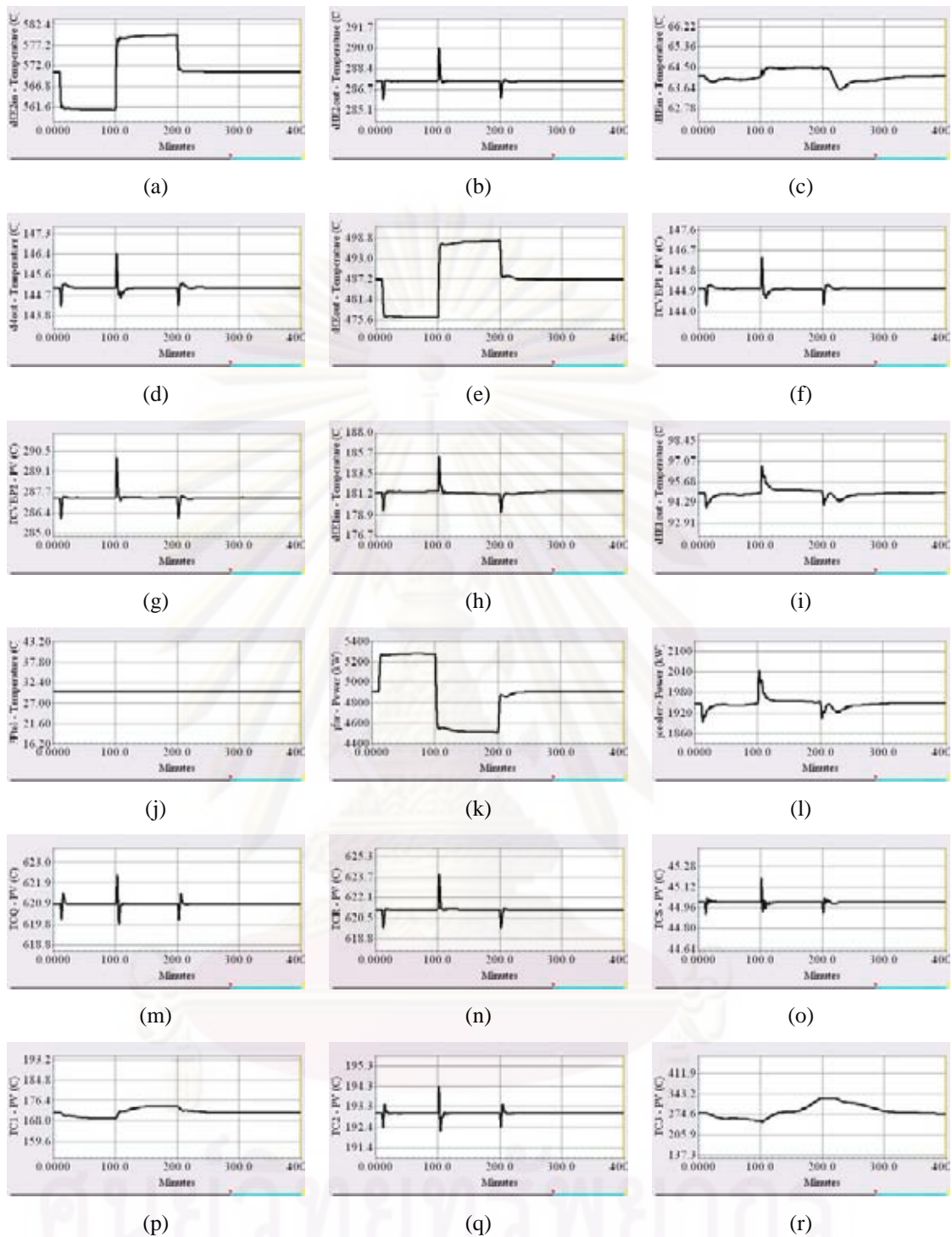

Figure 6.49 Dynamic responses of the typical HDA process HIP6.0 to a change in the heat load disturbance of hot stream (reactor product stream): CS₂, where: (a) FEHE2 hot inlet temperature, (b) FEHE2 hot outlet temperature, (c) FEHE1 cold inlet temperature, (d) FEHE2 cold inlet temperature, (e) FEHE2 cold outlet temperature, (f) FEHE1 bypass stream, (g) FEHE2 bypass stream, (h) FEHE1 hot inlet temperature, (i) FEHE1 hot outlet temperature, (j) fresh feed toluene temperature (k) furnace duty, (l) cooler duty, (m) quench temperature, (n) reactor inlet temperature, (o) separator temperature, (p) stabilizer column tray temperature, (q) product column tray temperature (r) recycle column tray temperature

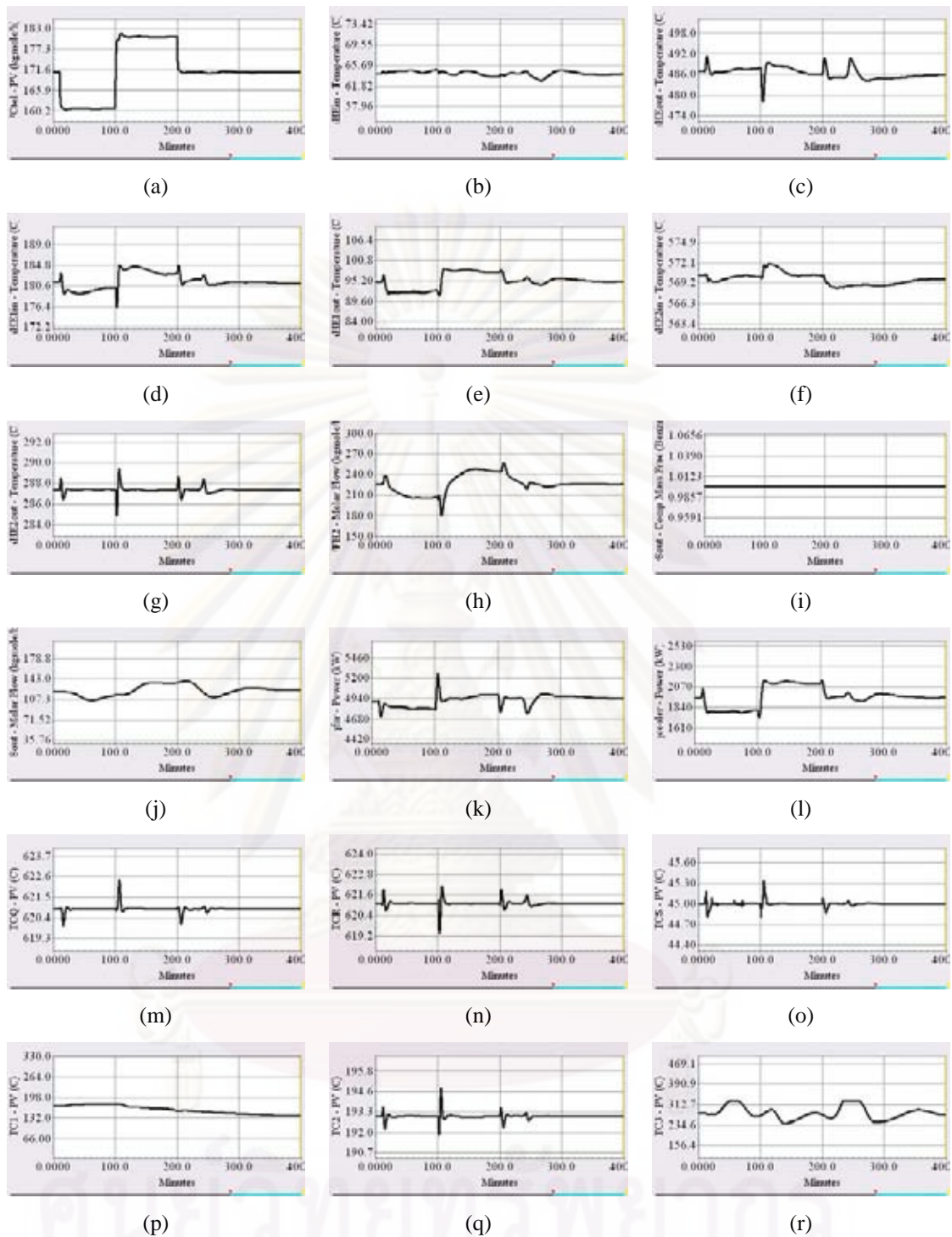

Figure 6.50 Dynamic responses of the typical HDA process HIP6.0 to a change in the total toluene feed flowrates: CS2, where: (a) total toluene feed flowrates, (b) FEHE1 cold inlet temperature, (c) FEHE2 cold outlet temperature, (d) FEHE1 hot inlet temperature, (e) FEHE1 hot outlet temperature, (f) FEHE2 hot inlet temperature, (g) FEHE2 hot outlet temperature, (h) fresh feed hydrogen flowrates, (i) benzene purity, (j) benzene flowrate (k) furnace duty, (l) cooler duty, (m) quench temperature, (n) reactor inlet temperature, (o) separator temperature, (p) stabilizer column tray temperature, (q) product column tray temperature (r) recycle column tray temperature

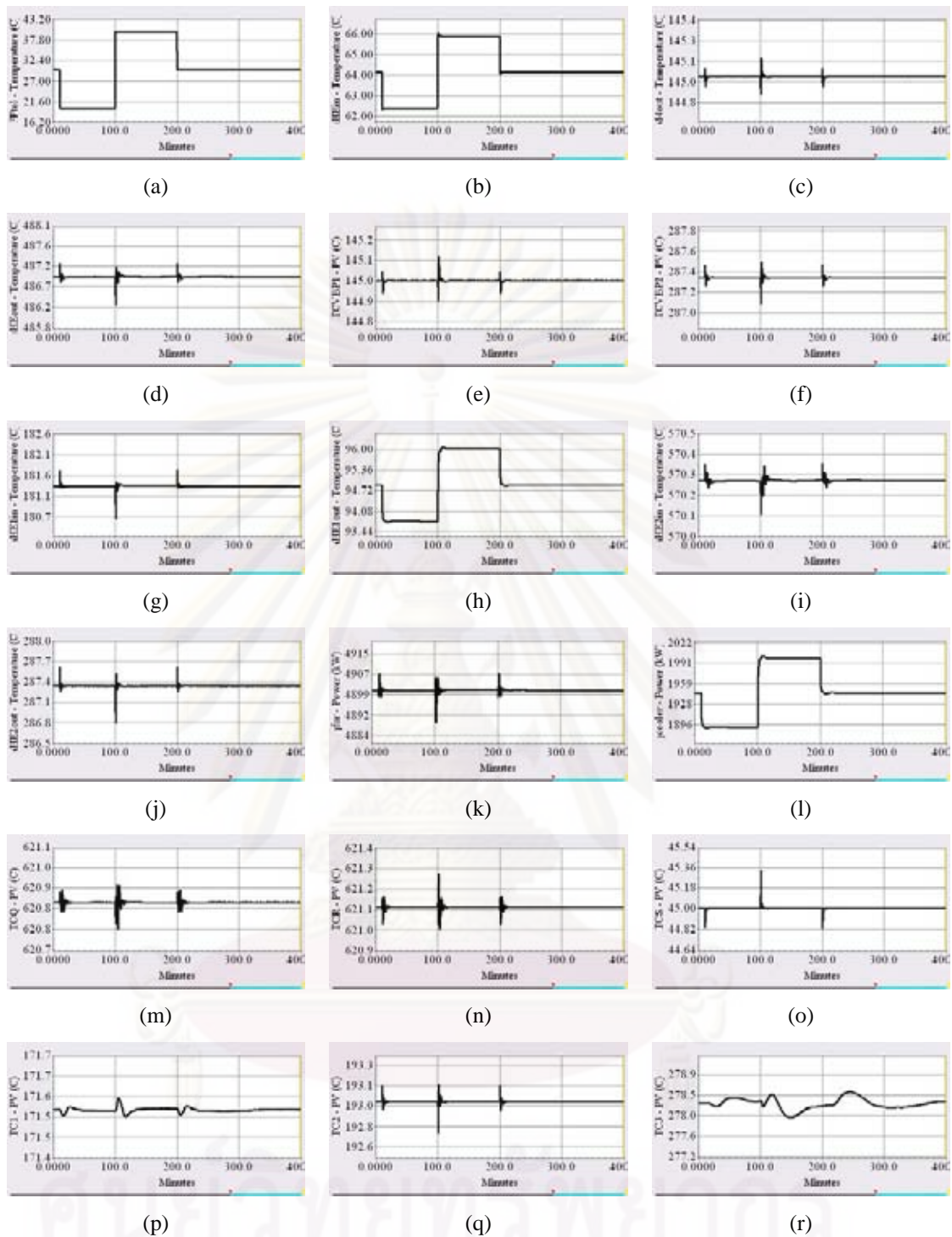

Figure 6.51 Dynamic responses of the typical HDA process HIP6.0 to a change in the heat load disturbance of cold stream (reactor feed stream): CS3, where: (a) fresh feed toluene temperature, (b) FEHE1 cold inlet temperature, (c) FEHE2 cold inlet temperature, (d) FEHE2 cold outlet temperature, (e) FEHE1 bypass stream, (f) FEHE2 bypass stream, (g) FEHE1 hot inlet temperature, (h) FEHE1 hot outlet temperature, (i) FEHE2 hot inlet temperature, (j) FEHE2 hot outlet temperature, (k) furnace duty, (l) cooler duty, (m) quench temperature, (n) reactor inlet temperature, (o) separator temperature, (p) stabilizer column tray temperature, (q) product column tray temperature (r) recycle column tray temperature

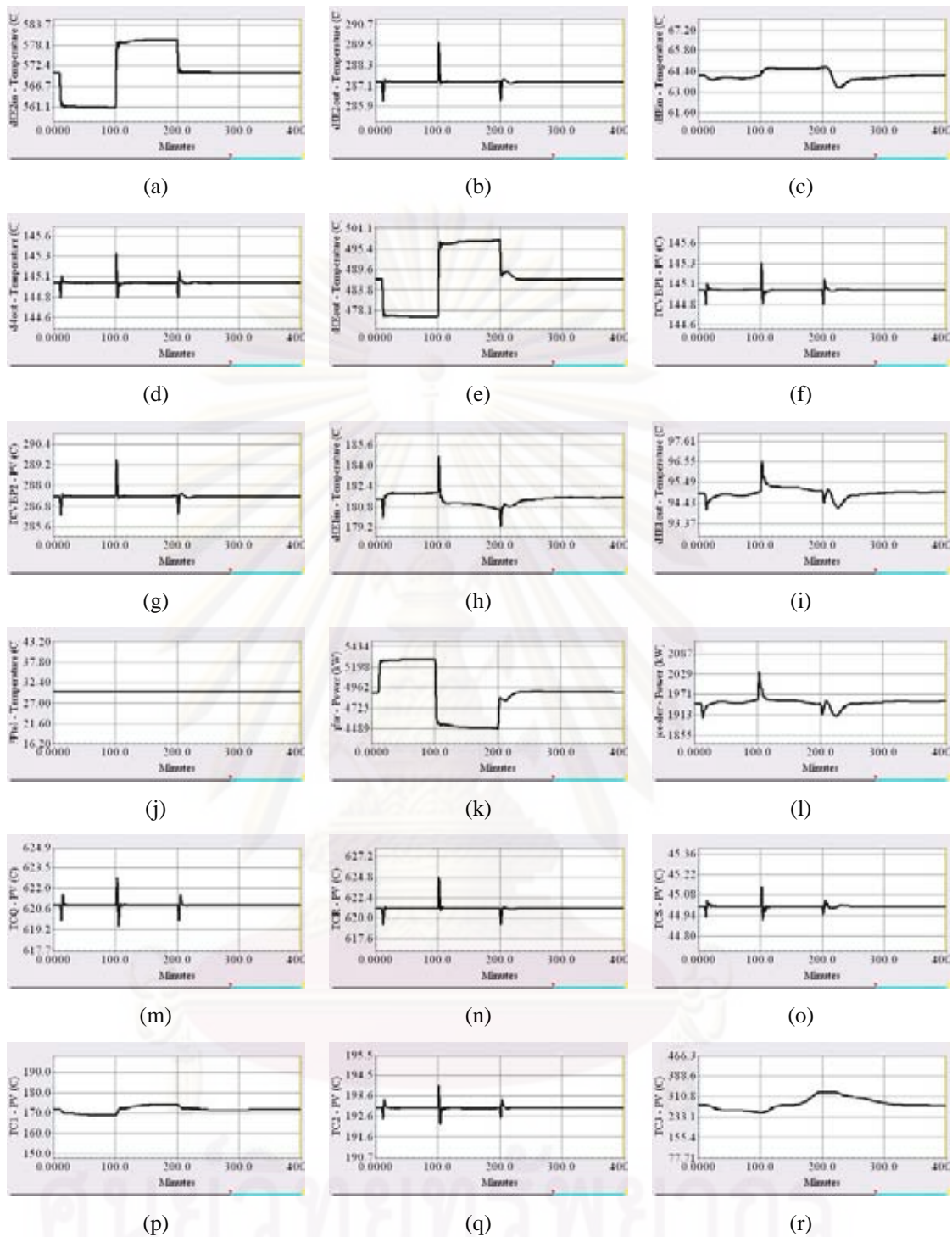

Figure 6.52 Dynamic responses of the typical HDA process HIP6.0 to a change in the heat load disturbance of hot stream (reactor product stream): CS3, where: (a) FEHE2 hot inlet temperature, (b) FEHE2 hot outlet temperature, (c) FEHE1 cold inlet temperature, (d) FEHE2 cold inlet temperature, (e) FEHE2 cold outlet temperature, (f) FEHE1 bypass stream, (g) FEHE2 bypass stream, (h) FEHE1 hot inlet temperature, (i) FEHE1 hot outlet temperature, (j) fresh feed toluene temperature (k) furnace duty, (l) cooler duty, (m) quench temperature, (n) reactor inlet temperature, (o) separator temperature, (p) stabilizer column tray temperature, (q) product column tray temperature (r) recycle column tray temperature

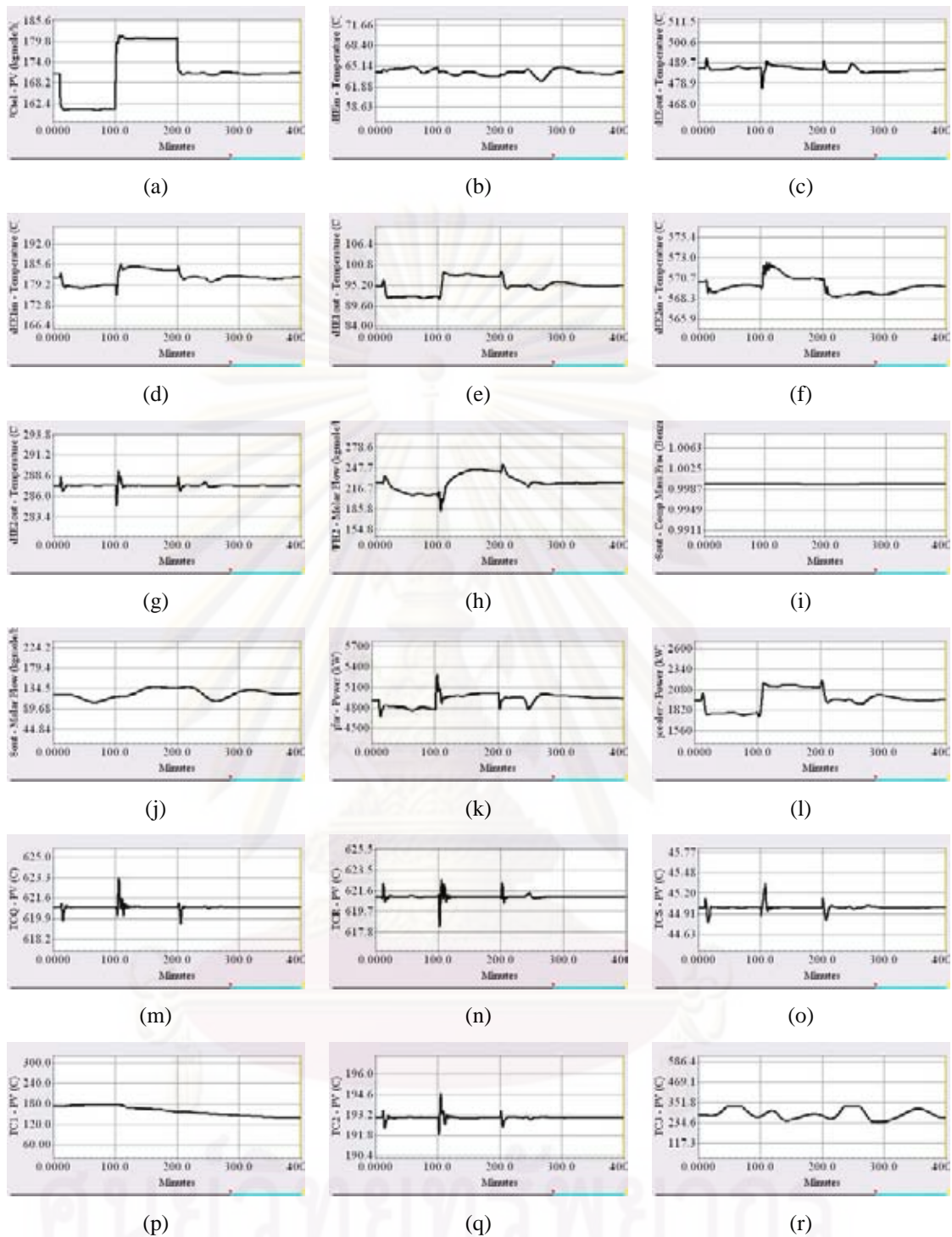

Figure 6.53 Dynamic responses of the typical HDA process HIP6.0 to a change in the total toluene feed flowrates: CS3, where: (a) total toluene feed flowrates, (b) FEHE1 cold inlet temperature, (c) FEHE2 cold outlet temperature, (d) FEHE1 hot inlet temperature, (e) FEHE1 hot outlet temperature, (f) FEHE2 hot inlet temperature, (g) FEHE2 hot outlet temperature, (h) fresh feed hydrogen flowrates, (i) benzene purity, (j) benzene flowrate (k) furnace duty, (l) cooler duty, (m) quench temperature, (n) reactor inlet temperature, (o) separator temperature, (p) stabilizer column tray temperature, (q) product column tray temperature (r) recycle column tray temperature

6.6 Dynamic Simulation Results of Complex Heat-Integrated HDA Process

In order to illustrate the dynamic behavior of the control structure in the complex heat-integrated HDA process HIP5 and 6. The complex heat-integrated HDA processes HIP5 are consists of HIP5.1 and 5.2. For the complex heat-integrated HDA processes HIP6 are consists of HIP6.1, 6.2 and 6.3. Three disturbance loads which are used to evaluate the dynamic performance of the new control structure (CS1, CS2 and CS3) are explained in this section.

6.6.1 Dynamic Simulation Results of Complex Heat-Integrated HDA Process HIP5.1 and HIP5.2

Three disturbance loads are used to evaluate the dynamic performance of the new control structure (CS1, CS2 and CS3) for HDA process HIP5.1 and HIP5.2.

6.6.1.1 Change the Heat Load Disturbance of Cold Streams (Reactor Feed Stream)

The dynamic responses of the control system of the complex heat-integrated HDA process HIP5.1 are shown in Figure 6.54, 6.57 and 6.60, and for HIP5.2 are shown in Figure 6.63, 6.66 and 6.69. In order to make this disturbance, first the fresh toluene feed temperature is decreased from 30 to 20°C at time equals 10 minutes, and the temperature is increased from 20 to 40°C at time equals 100 minutes, then its temperature is returned to its nominal value of 30°C at time equals 200 minutes (see Figure 6.54.a, 6.57.a, 6.60.a, 6.63.a, 6.66.a and 6.69.a).

The three new control structures (CS1, CS2 and CS3) give the same result for shifting the thermal disturbance load in cold steam (reactor feed stream) to heater or cooler as follows. First, the cold inlet temperature of FEHE is decreased and then both the cold and hot outlet temperatures of FEHE decrease suddenly. In order the hot outlet temperature is decreased to a desired condition, the control action to control the cold outlet temperature of FEHE. As a result, the cold and hot outlet temperature of FEHE rapidly drops to a new steady state value and the cooler duty decreases (see Figure 6.54.1, 6.57.1, 6.60.1, 6.63.1, 6.66.1 and 6.69.1). When the cold inlet temperature

of FEHE increases, both the cold and hot outlet temperatures of FEHE increase. In order to the hot outlet temperature is increased to a desired condition, the control action to control the cold outlet temperature of FEHE. As a result, the cold and hot outlet temperature of FEHE quickly increases to a new steady state value and the furnace duty decreases (see Figure 6.54.k, 6.57.k, 6.60.k, 6.63.k, 6.66.k and 6.69.k).

As can be see, this disturbance load has a little bit effect to the tray temperature in stabilizer column, product column and recycle columns however the three new control structures can control the tray temperature in three distillation columns slightly well. The reactor inlet temperature, the quench temperature, the separator temperature are slightly well controlled but the dynamic response of CS1 is smoother than CS2 and CS3.

6.6.1.2 Change the Heat Load Disturbance of Hot Streams (Reactor Product Stream)

The dynamic responses of the control system of the complex heat-integrated HDA process HIP5.1 are shown in Figure 6.55, 6.58 and 6.61, and for HIP5.2 are shown in Figure 6.64, 6.67 and 6.70. This disturbance is made as follows: first the set point of FEHE-hot-inlet temperature controller (i.e. TCX1) is decreased from 621.1 to 611.1°C at time equals 10 minutes and the temperature is increased from 611.1 to 631.1°C at time equals 100 minutes, then its temperature is returned to its nominal value of 621.1°C at time equals 200 minutes (see Figure 6.55.a, 6.58.a, 6.61.a, 6.64.a, 6.67.a and 6.70.a). As can be seen, this temperature response is very fast, the new steady state is reached quickly

Since the hot outlet temperature of FEHE is controlled to prevent the propagation of the thermal disturbance, both the positive and negative disturbance loads of the hot stream are shifted to the furnace utility. The cooler duty will be decreased in this case. Consider the case when the hot inlet temperature of FEHE increases, this is a desired condition to shift the disturbance load to the cold stream. Therefore, the cooler duty increases to a new steady state value.

For the tray temperatures in the stabilizer, product and recycle columns are slightly well controlled but CS2 is more oscillation than CS1 and CS3. The reactor

inlet temperature, the quench temperature, the separator temperature are slightly well controlled but the dynamic response of CS1 is smoother than CS2 and CS3.

6.6.1.3 Change the Total Toluene Feed Flowrates

The dynamic responses of the control system of the complex heat-integrated HDA process HIP5.1 are shown in Figure 6.56, 6.59 and 6.62, and for HIP5.2 are shown in Figure 6.65, 6.68 and 6.71. This disturbance is made by decreasing toluene flowrates from 172.3 to 162.3 kgmole/h at time equals 10 minutes, and the flowrates is increased from 162.3 to 182.3 kgmole/h at time equals 100 minutes, then its flowrates is returned to its nominal value of 172.3 kgmole/h at time equals 200 minutes (see Figure 6.56.a, 6.59.a, 6.62.a, 6.65.a, 6.68.a and 6.71.a).

The dynamic result can be seen that the drop in total toluene feed flowrates reduces the reaction rate, so fresh feed hydrogen flowrates (see Figure 6.56.h, 6.59.h, 6.62.h, 6.65.h, 6.68.h and 6.71.h), the benzene product flowrates drops (see Figure 6.56.j, 6.59.j, 6.62.j, 6.65.j, 6.68.j and 6.71.j) and the benzene product quality is shown in Figure 6.56.i, 6.59.i, 6.62.i, 6.65.i, 6.68.i and 6.71.i. Consider the case when the total toluene feed flowrates increase and the benzene product flowrates increase because of the reaction rate enlargement. The deviation of benzene product quality from nominal value in CS1, CS2 and CS3 are slightly similar when total toluene feed flowrates change.

As can be see, this disturbance has height effect to tray temperatures in the tray temperatures in the stabilizer, product and recycle columns however all control structure can the tray temperatures in the three columns slightly well.

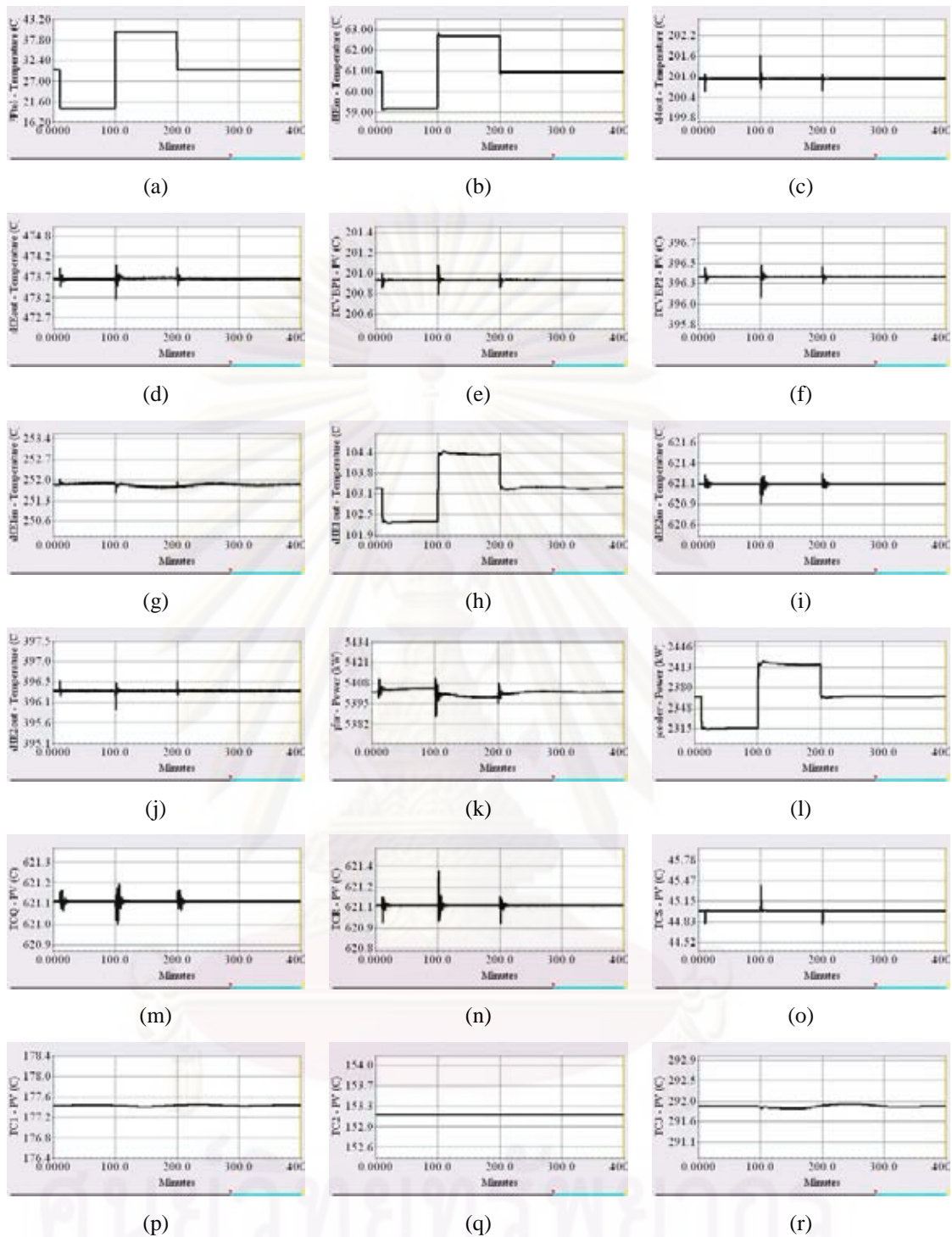

Figure 6.54 Dynamic responses of the HDA process HIP5.1 to a change in the heat load disturbance of cold stream (reactor feed stream): CS1, where: (a) fresh feed toluene temperature, (b) FEHE1 cold inlet temperature, (c) FEHE2 cold inlet temperature, (d) FEHE2 cold outlet temperature, (e) FEHE1 bypass stream, (f) FEHE2 bypass stream, (g) FEHE1 hot inlet temperature, (h) FEHE1 hot outlet temperature, (i) FEHE2 hot inlet temperature, (j) FEHE2 hot outlet temperature, (k) furnace duty, (l) cooler duty, (m) quench temperature, (n) reactor inlet temperature, (o) separator temperature, (p) stabilizer column tray temperature, (q) product column tray temperature (r) recycle column tray temperature

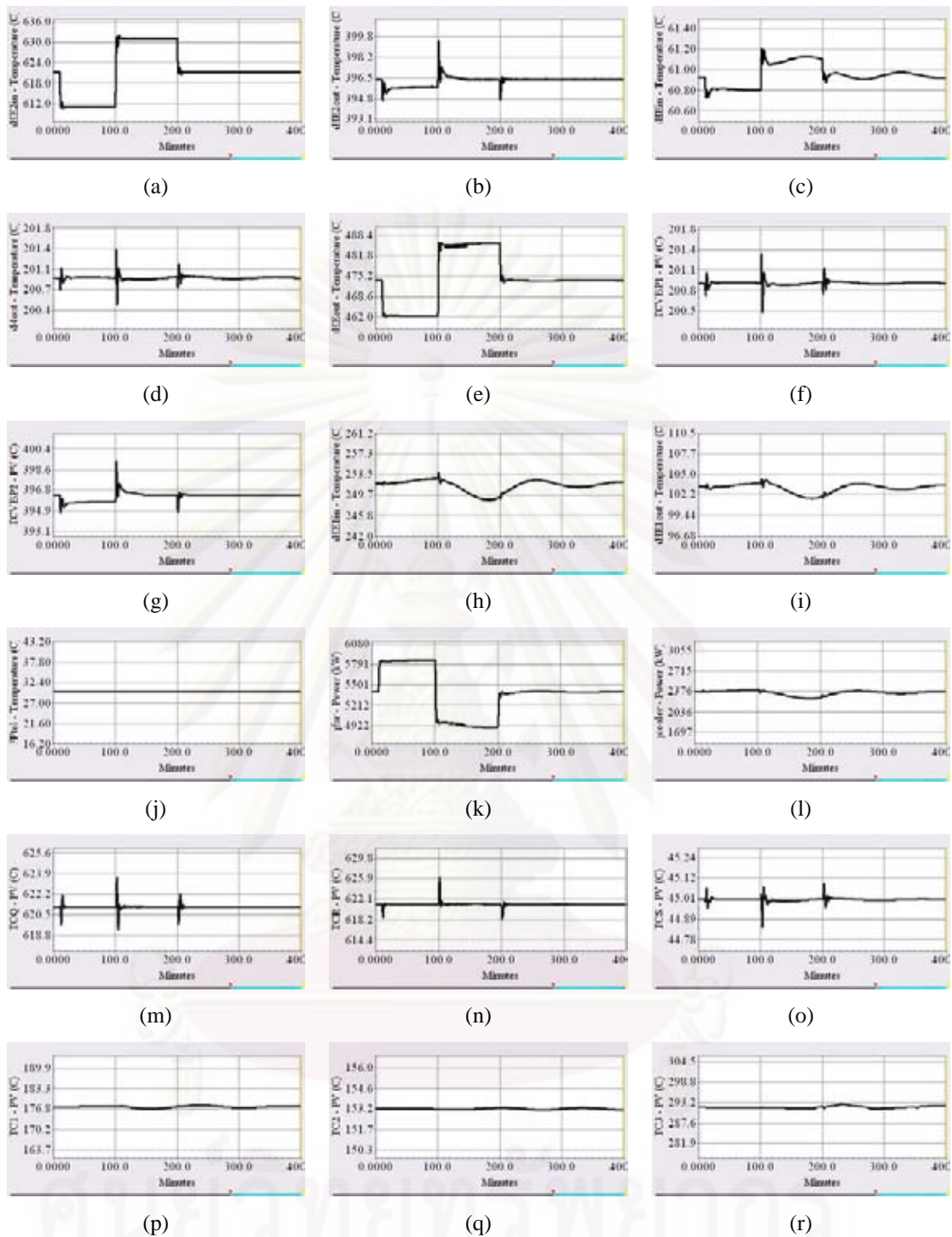

Figure 6.55 Dynamic responses of the HDA process HIP5.1 to a change in the heat load disturbance of hot stream (reactor product stream): CS1, where: (a) FEHE2 hot inlet temperature, (b) FEHE2 hot outlet temperature, (c) FEHE1 cold inlet temperature, (d) FEHE2 cold inlet temperature, (e) FEHE2 cold outlet temperature, (f) FEHE1 bypass stream, (g) FEHE2 bypass stream, (h) FEHE1 hot inlet temperature, (i) FEHE1 hot outlet temperature, (j) fresh feed toluene temperature (k) furnace duty, (l) cooler duty, (m) quench temperature, (n) reactor inlet temperature, (o) separator temperature, (p) stabilizer column tray temperature, (q) product column tray temperature (r) recycle column tray temperature

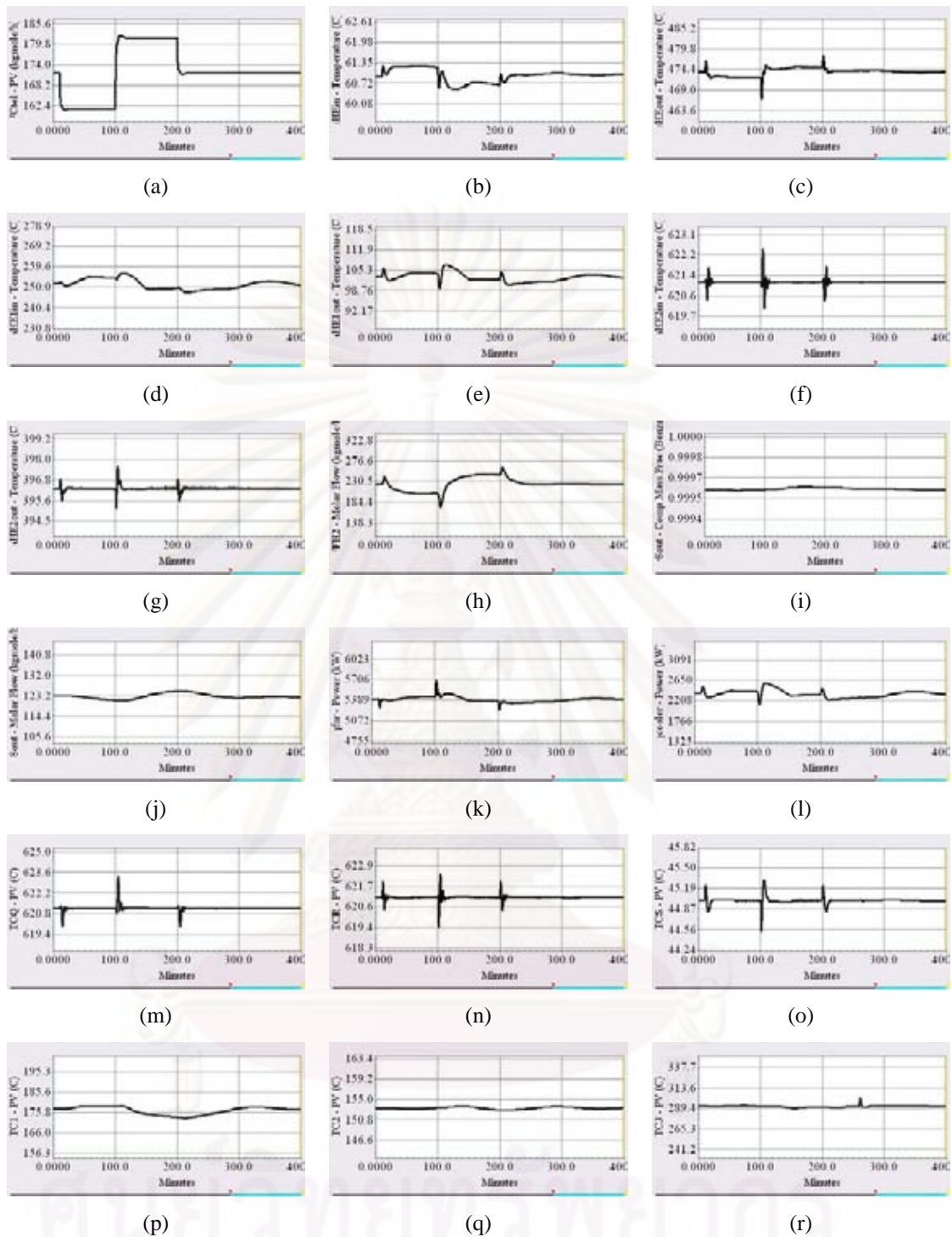

Figure 6.56 Dynamic responses of the HDA process HIP5.1 to a change in the total toluene feed flowrates: CS1, where: (a) total toluene feed flowrates, (b) FEHE1 cold inlet temperature, (c) FEHE2 cold outlet temperature, (d) FEHE1 hot inlet temperature, (e) FEHE1 hot outlet temperature, (f) FEHE2 hot inlet temperature, (g) FEHE2 hot outlet temperature, (h) fresh feed hydrogen flowrates, (i) benzene purity, (j) benzene flowrate (k) furnace duty, (l) cooler duty, (m) quench temperature, (n) reactor inlet temperature, (o) separator temperature, (p) stabilizer column tray temperature, (q) product column tray temperature (r) recycle column tray temperature

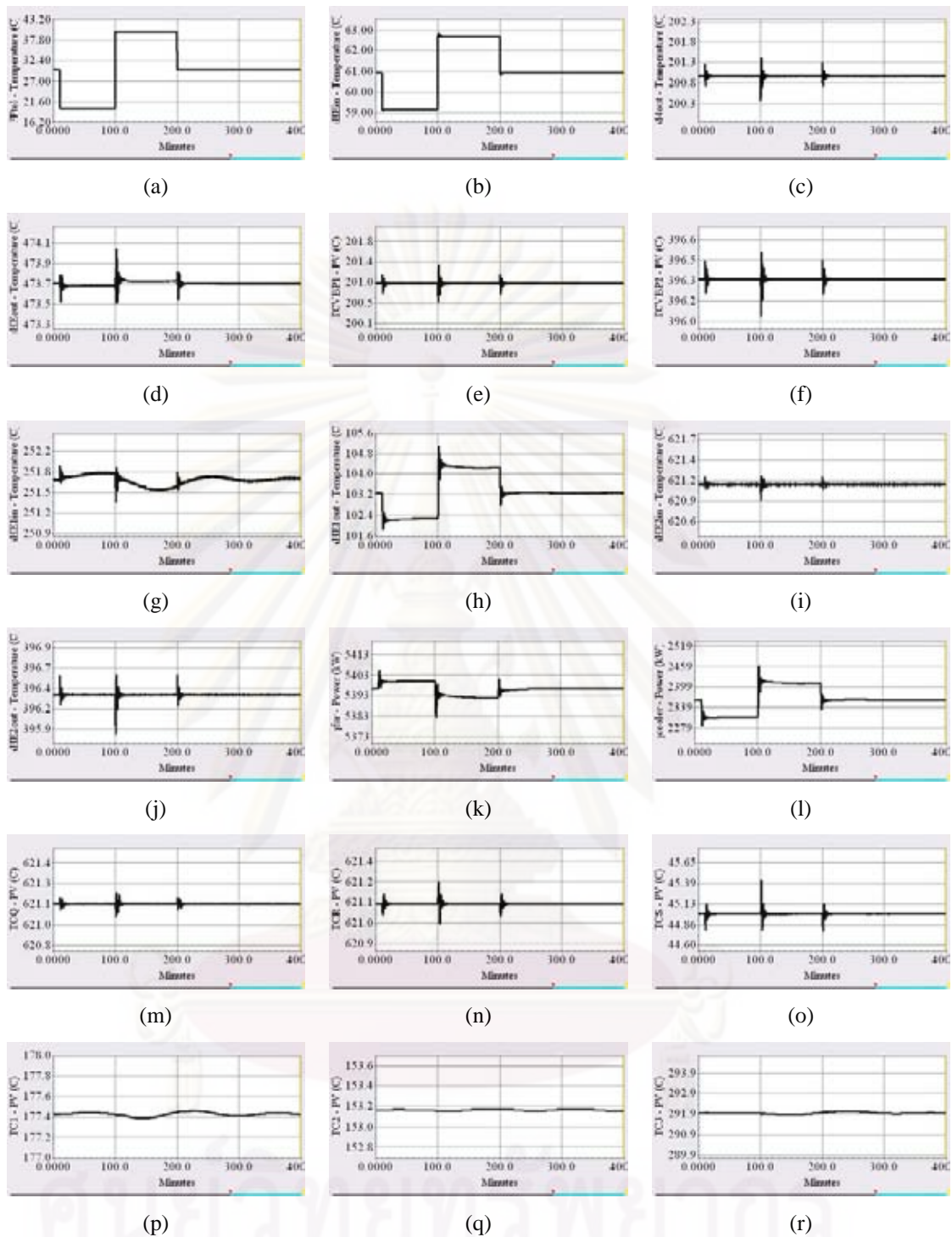

Figure 6.57 Dynamic responses of the HDA process HIP5.1 to a change in the heat load disturbance of cold stream (reactor feed stream): CS2, where: (a) fresh feed toluene temperature, (b) FEHE1 cold inlet temperature, (c) FEHE2 cold inlet temperature, (d) FEHE2 cold outlet temperature, (e) FEHE1 bypass stream, (f) FEHE2 bypass stream, (g) FEHE1 hot inlet temperature, (h) FEHE1 hot outlet temperature, (i) FEHE2 hot inlet temperature, (j) FEHE2 hot outlet temperature, (k) furnace duty, (l) cooler duty, (m) quench temperature, (n) reactor inlet temperature, (o) separator temperature, (p) stabilizer column tray temperature, (q) product column tray temperature (r) recycle column tray temperature

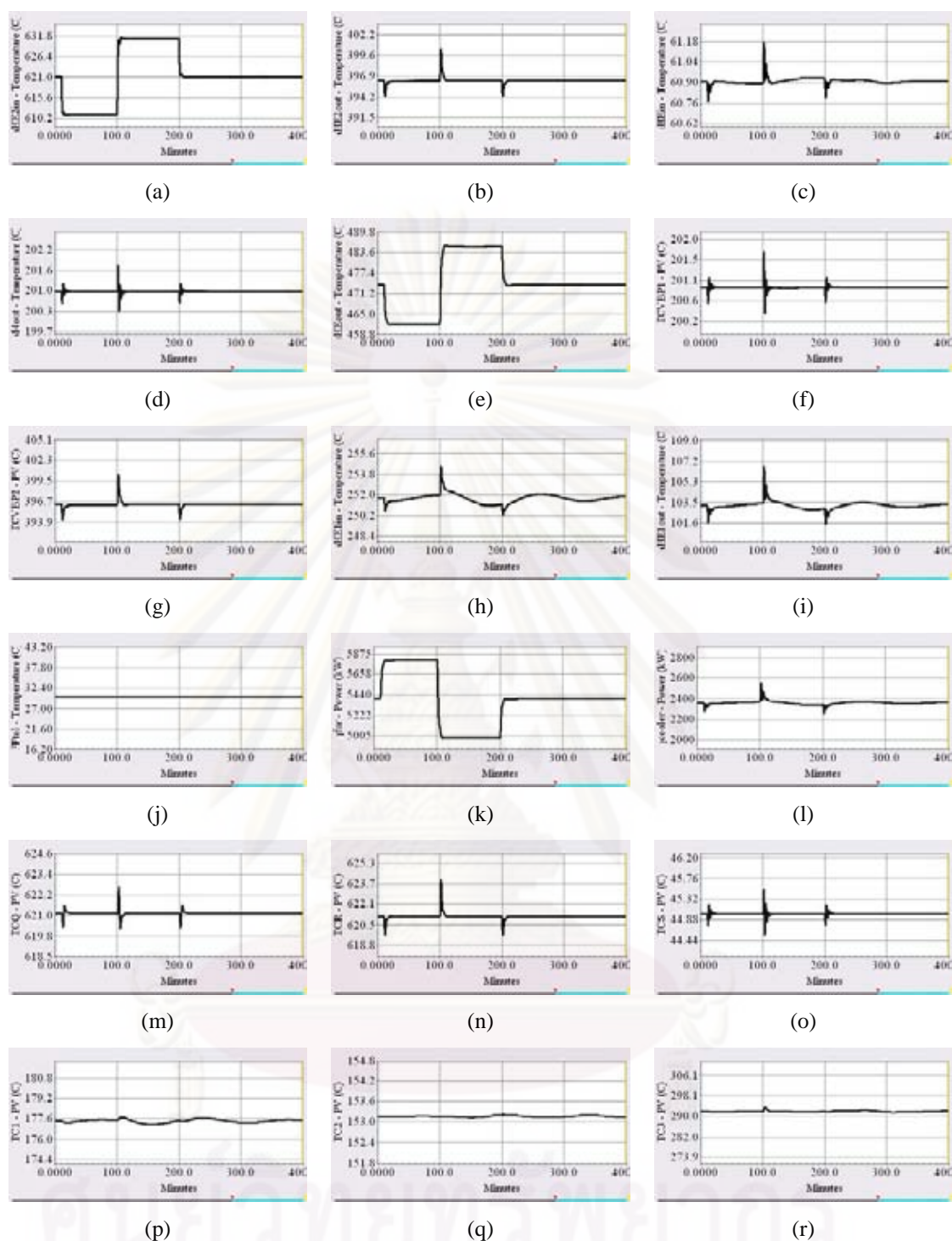

Figure 6.58 Dynamic responses of the HDA process HIP5.1 to a change in the heat load disturbance of hot stream (reactor product stream): CS₂, where: (a) FEHE2 hot inlet temperature, (b) FEHE2 hot outlet temperature, (c) FEHE1 cold inlet temperature, (d) FEHE2 cold inlet temperature, (e) FEHE2 cold outlet temperature, (f) FEHE1 bypass stream, (g) FEHE2 bypass stream, (h) FEHE1 hot inlet temperature, (i) FEHE1 hot outlet temperature, (j) fresh feed toluene temperature (k) furnace duty, (l) cooler duty, (m) quench temperature, (n) reactor inlet temperature, (o) separator temperature, (p) stabilizer column tray temperature, (q) product column tray temperature (r) recycle column tray temperature

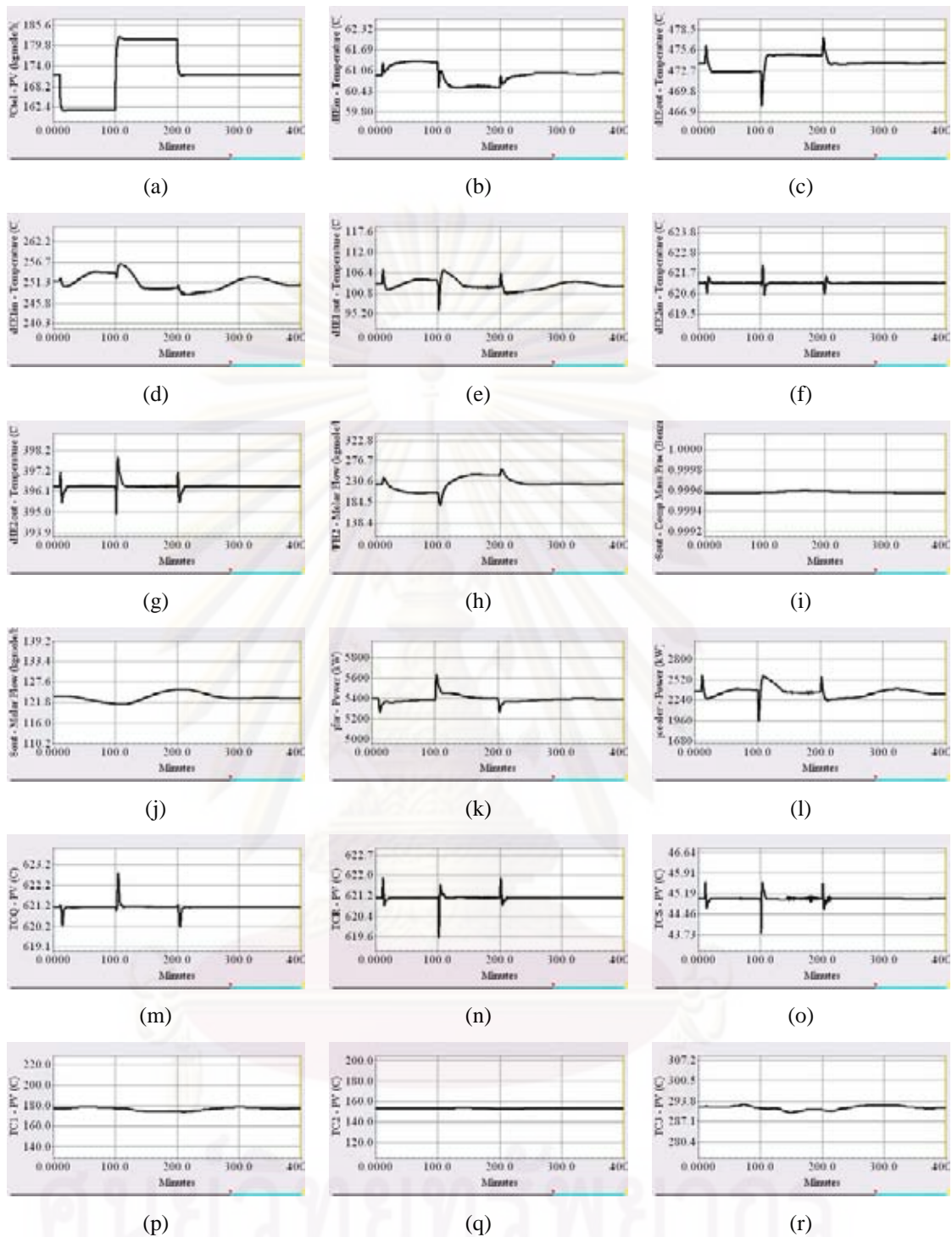

Figure 6.59 Dynamic responses of the HDA process HIP5.1 to a change in the total toluene feed flowrates: CS₂, where: (a) total toluene feed flowrates, (b) FEHE1 cold inlet temperature, (c) FEHE2 cold outlet temperature, (d) FEHE1 hot inlet temperature, (e) FEHE1 hot outlet temperature, (f) FEHE2 hot inlet temperature, (g) FEHE2 hot outlet temperature, (h) fresh feed hydrogen flowrates, (i) benzene purity, (j) benzene flowrate (k) furnace duty, (l) cooler duty, (m) quench temperature, (n) reactor inlet temperature, (o) separator temperature, (p) stabilizer column tray temperature, (q) product column tray temperature (r) recycle column tray temperature

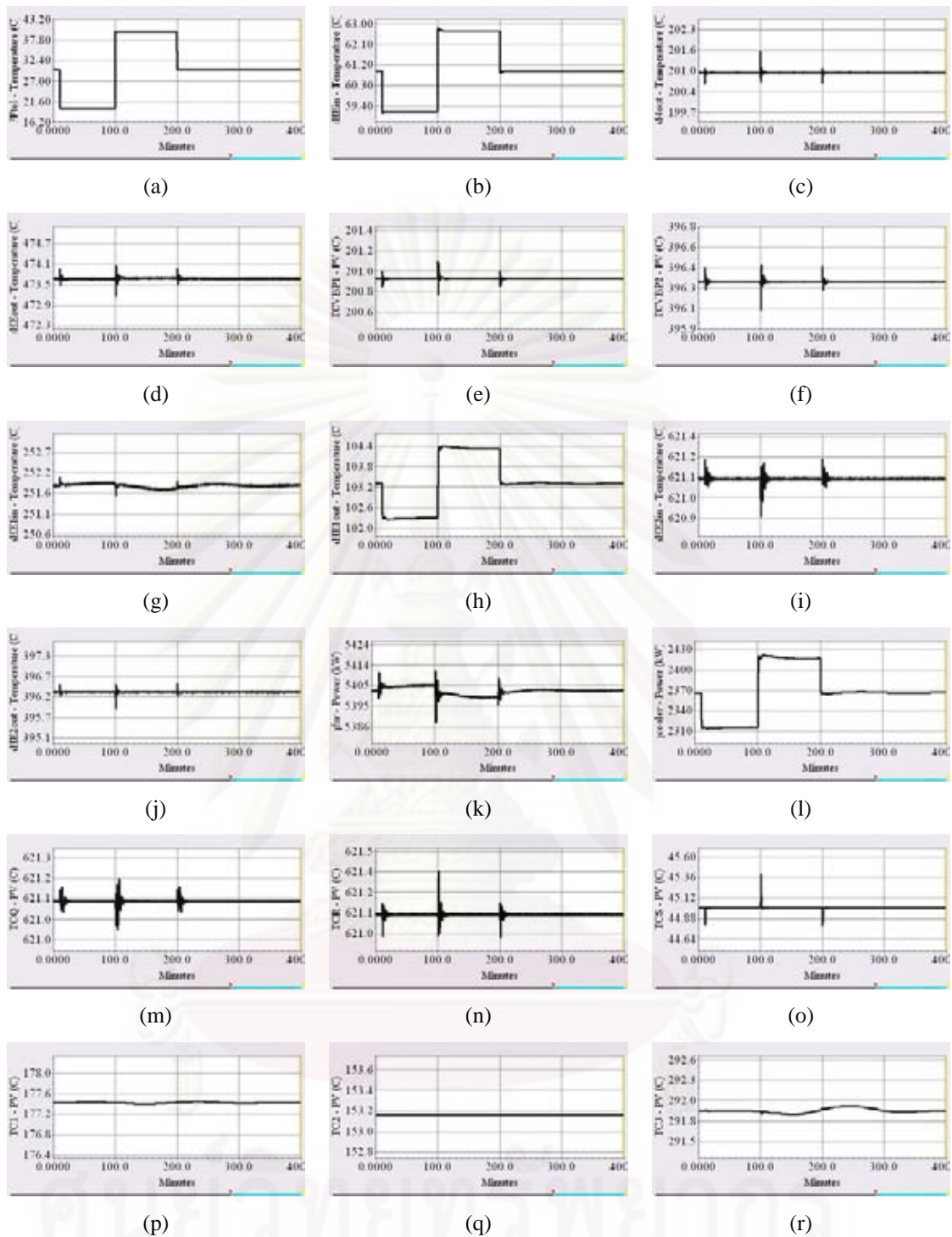

Figure 6.60 Dynamic responses of the HDA process HIP5.1 to a change in the heat load disturbance of cold stream (reactor feed stream): CS3, where: (a) fresh feed toluene temperature, (b) FEHE1 cold inlet temperature, (c) FEHE2 cold inlet temperature, (d) FEHE2 cold outlet temperature, (e) FEHE1 bypass stream, (f) FEHE2 bypass stream, (g) FEHE1 hot inlet temperature, (h) FEHE1 hot outlet temperature, (i) FEHE2 hot inlet temperature, (j) FEHE2 hot outlet temperature, (k) furnace duty, (l) cooler duty, (m) quench temperature, (n) reactor inlet temperature, (o) separator temperature, (p) stabilizer column tray temperature, (q) product column tray temperature (r) recycle column tray temperature

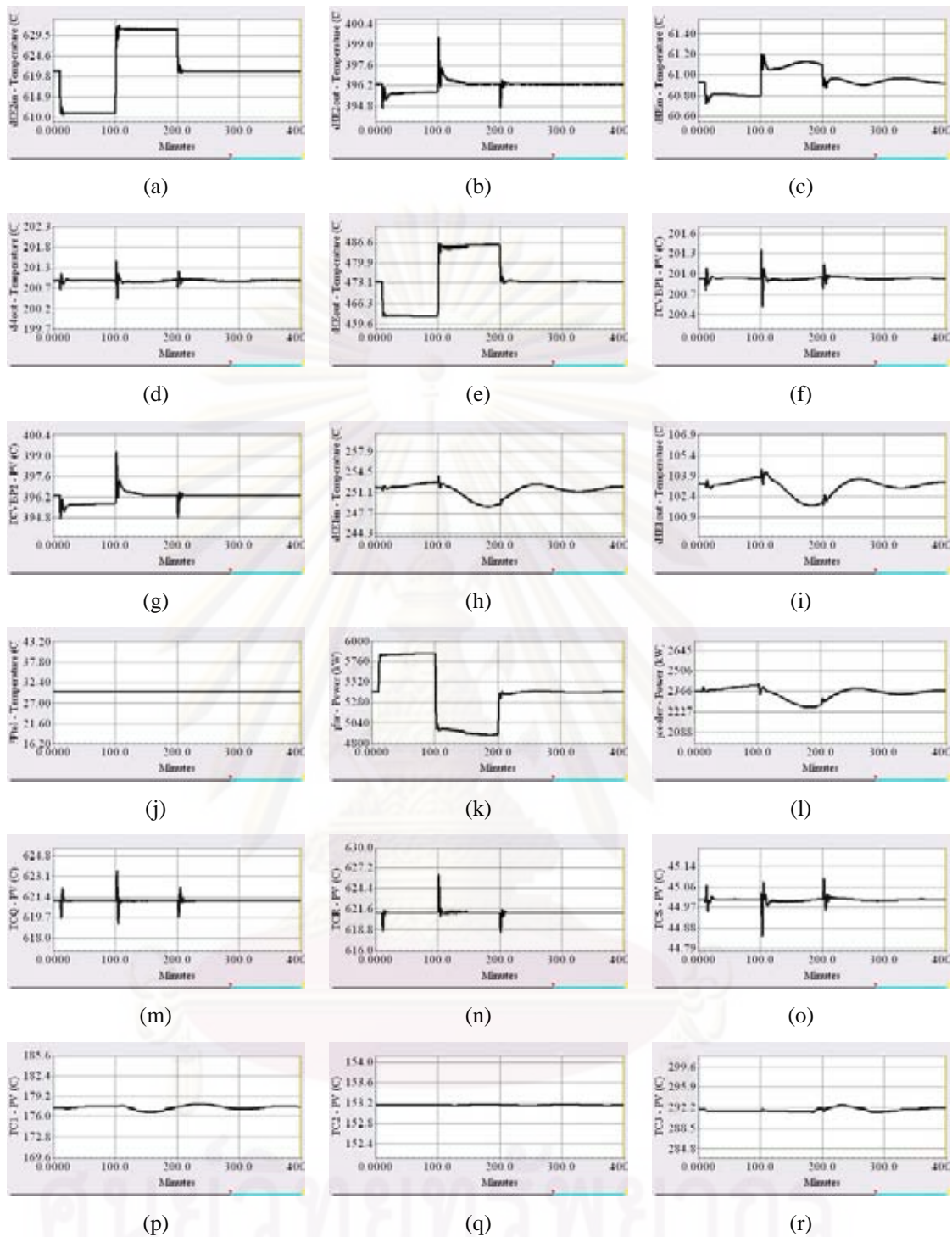

Figure 6.61 Dynamic responses of the HDA process HIP5.1 to a change in the heat load disturbance of hot stream (reactor product stream): CS3, where: (a) FEHE2 hot inlet temperature, (b) FEHE2 hot outlet temperature, (c) FEHE1 cold inlet temperature, (d) FEHE2 cold inlet temperature, (e) FEHE2 cold outlet temperature, (f) FEHE1 bypass stream, (g) FEHE2 bypass stream, (h) FEHE1 hot inlet temperature, (i) FEHE1 hot outlet temperature, (j) fresh feed toluene temperature (k) furnace duty, (l) cooler duty, (m) quench temperature, (n) reactor inlet temperature, (o) separator temperature, (p) stabilizer column tray temperature, (q) product column tray temperature (r) recycle column tray temperature

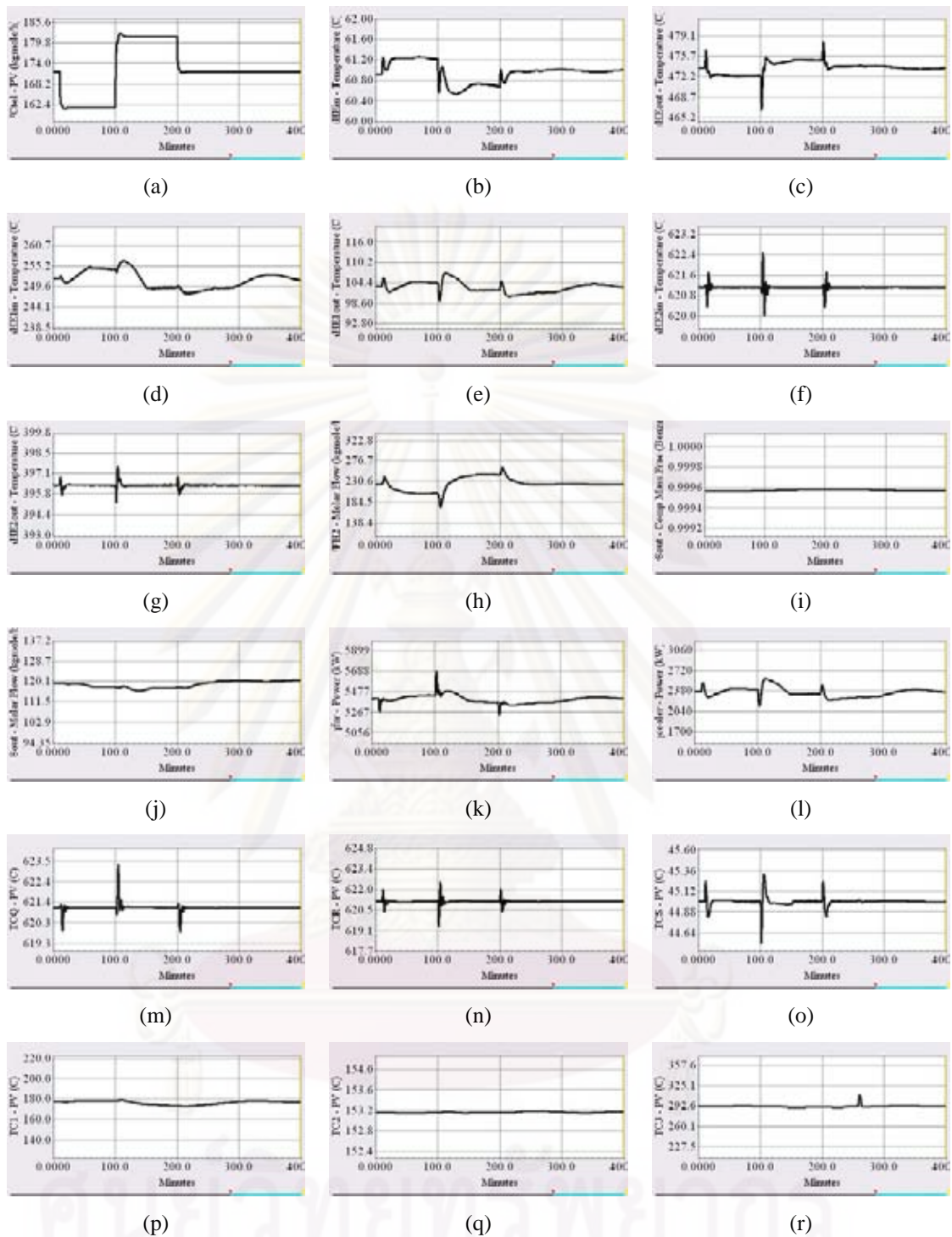

Figure 6.62 Dynamic responses of the HDA process HIP5.1 to a change in the total toluene feed flowrates: CS3, where: (a) total toluene feed flowrates, (b) FEHE1 cold inlet temperature, (c) FEHE2 cold outlet temperature, (d) FEHE1 hot inlet temperature, (e) FEHE1 hot outlet temperature, (f) FEHE2 hot inlet temperature, (g) FEHE2 hot outlet temperature, (h) fresh feed hydrogen flowrates, (i) benzene purity, (j) benzene flowrate (k) furnace duty, (l) cooler duty, (m) quench temperature, (n) reactor inlet temperature, (o) separator temperature, (p) stabilizer column tray temperature, (q) product column tray temperature (r) recycle column tray temperature

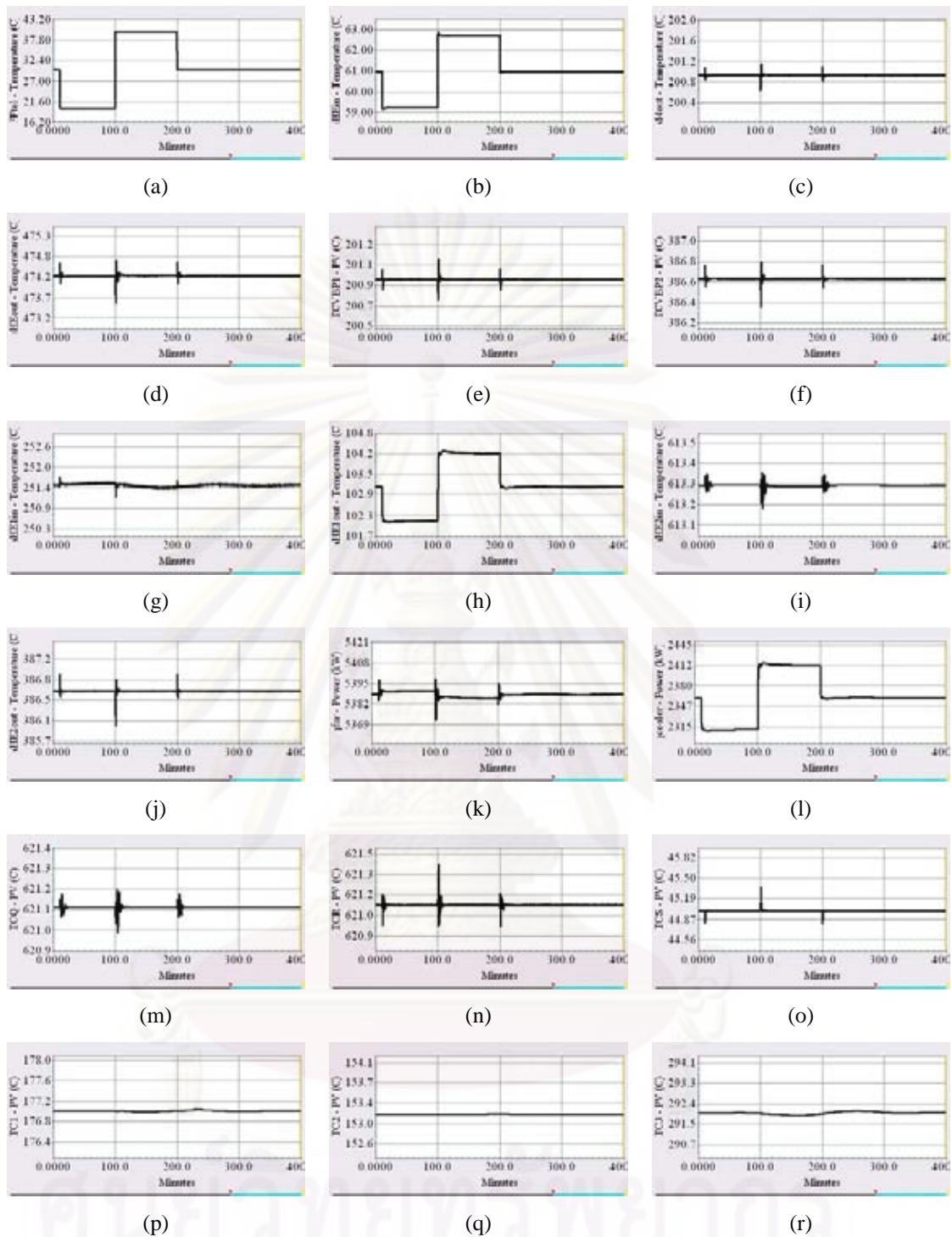

Figure 6.63 Dynamic responses of the HDA process HIP5.2 to a change in the heat load disturbance of cold stream (reactor feed stream): CS1, where: (a) fresh feed toluene temperature, (b) FEHE1 cold inlet temperature, (c) FEHE2 cold inlet temperature, (d) FEHE2 cold outlet temperature, (e) FEHE1 bypass stream, (f) FEHE2 bypass stream, (g) FEHE1 hot inlet temperature, (h) FEHE1 hot outlet temperature, (i) FEHE2 hot inlet temperature, (j) FEHE2 hot outlet temperature, (k) furnace duty, (l) cooler duty, (m) quench temperature, (n) reactor inlet temperature, (o) separator temperature, (p) stabilizer column tray temperature, (q) product column tray temperature (r) recycle column tray temperature

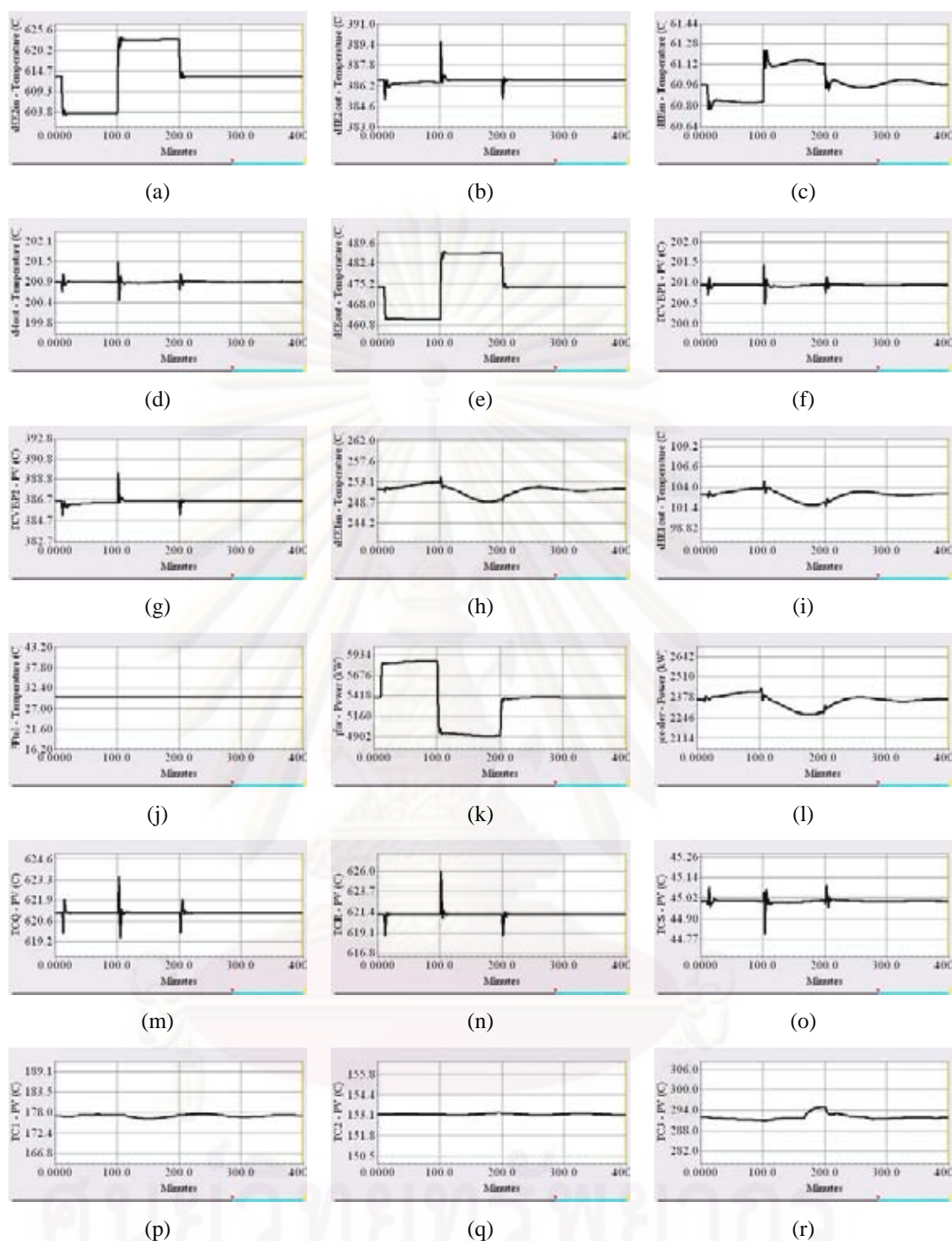

Figure 6.64 Dynamic responses of the HDA process HIP5.2 to a change in the heat load disturbance of hot stream (reactor product stream): CS1, where: (a) FEHE2 hot inlet temperature, (b) FEHE2 hot outlet temperature, (c) FEHE1 cold inlet temperature, (d) FEHE2 cold inlet temperature, (e) FEHE2 cold outlet temperature, (f) FEHE1 bypass stream, (g) FEHE2 bypass stream, (h) FEHE1 hot inlet temperature, (i) FEHE1 hot outlet temperature, (j) fresh feed toluene temperature (k) furnace duty, (l) cooler duty, (m) quench temperature, (n) reactor inlet temperature, (o) separator temperature, (p) stabilizer column tray temperature, (q) product column tray temperature (r) recycle column tray temperature

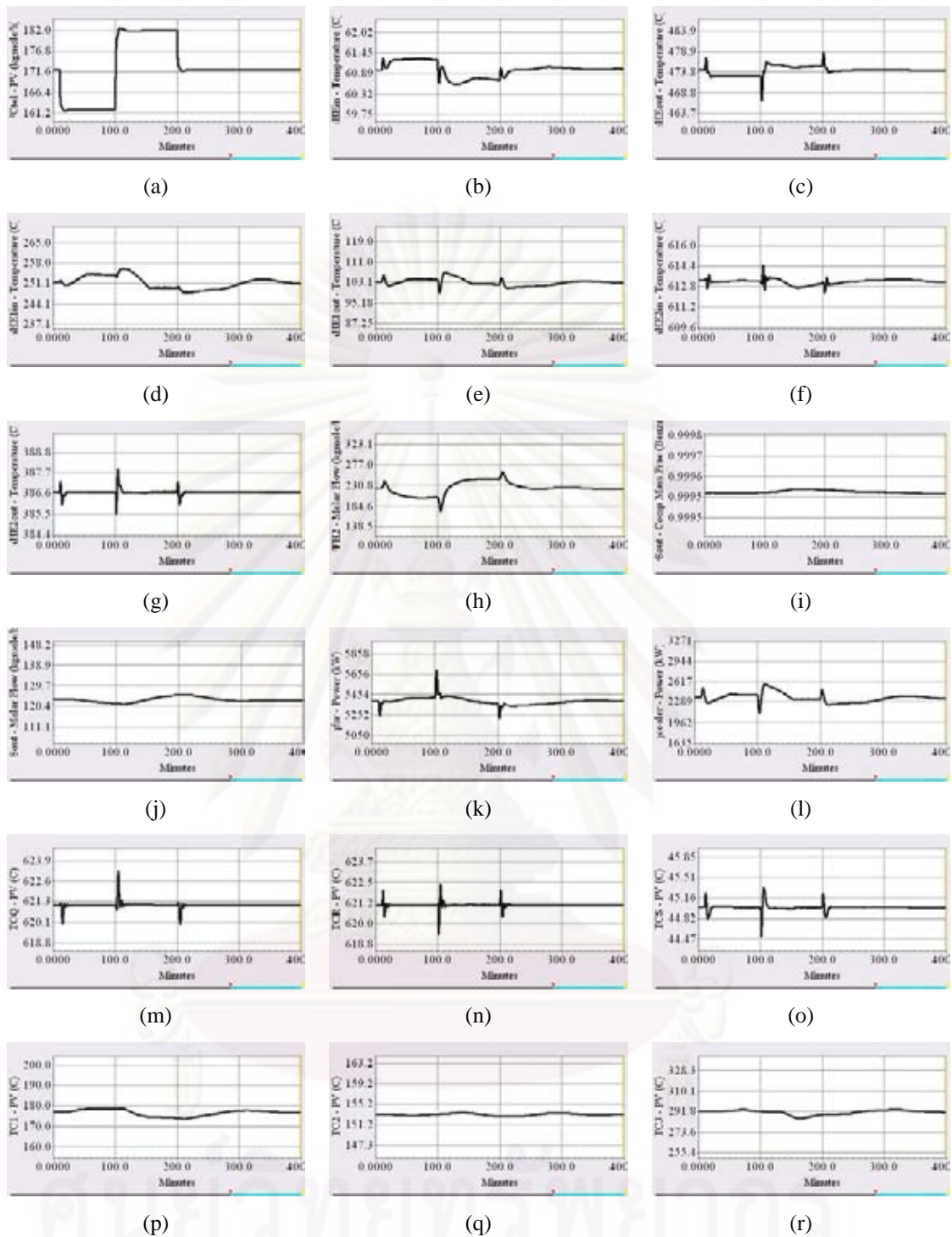

Figure 6.65 Dynamic responses of the HDA process HIP5.2 to a change in the total toluene feed flowrates: CS1, where: (a) total toluene feed flowrates, (b) FEHE1 cold inlet temperature, (c) FEHE2 cold outlet temperature, (d) FEHE1 hot inlet temperature, (e) FEHE1 hot outlet temperature, (f) FEHE2 hot inlet temperature, (g) FEHE2 hot outlet temperature, (h) fresh feed hydrogen flowrates, (i) benzene purity, (j) benzene flowrate (k) furnace duty, (l) cooler duty, (m) quench temperature, (n) reactor inlet temperature, (o) separator temperature, (p) stabilizer column tray temperature, (q) product column tray temperature (r) recycle column tray temperature

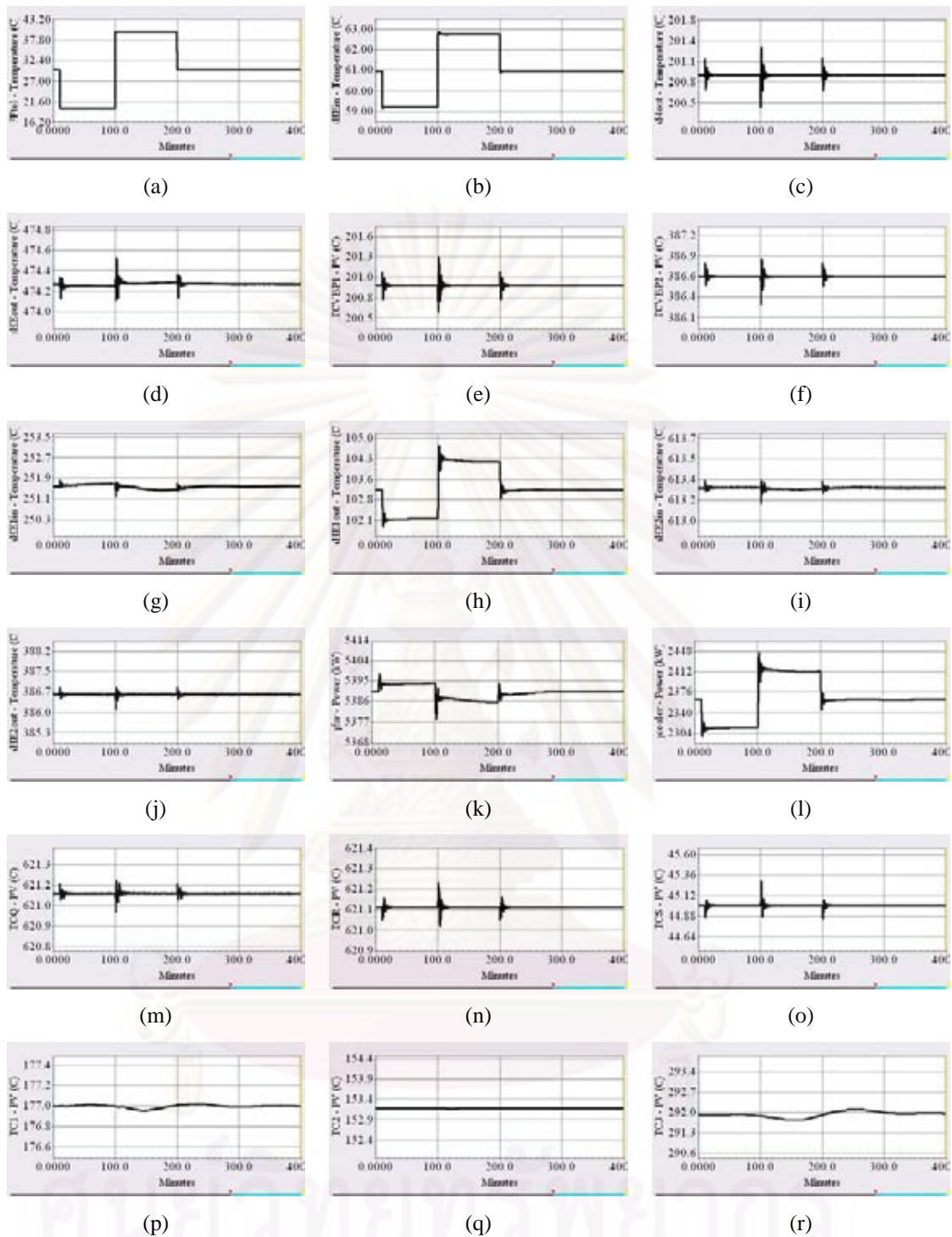

Figure 6.66 Dynamic responses of the HDA process HIP5.2 to a change in the heat load disturbance of cold stream (reactor feed stream): CS2, where: (a) fresh feed toluene temperature, (b) FEHE1 cold inlet temperature, (c) FEHE2 cold inlet temperature, (d) FEHE2 cold outlet temperature, (e) FEHE1 bypass stream, (f) FEHE2 bypass stream, (g) FEHE1 hot inlet temperature, (h) FEHE1 hot outlet temperature, (i) FEHE2 hot inlet temperature, (j) FEHE2 hot outlet temperature, (k) furnace duty, (l) cooler duty, (m) quench temperature, (n) reactor inlet temperature, (o) separator temperature, (p) stabilizer column tray temperature, (q) product column tray temperature (r) recycle column tray temperature

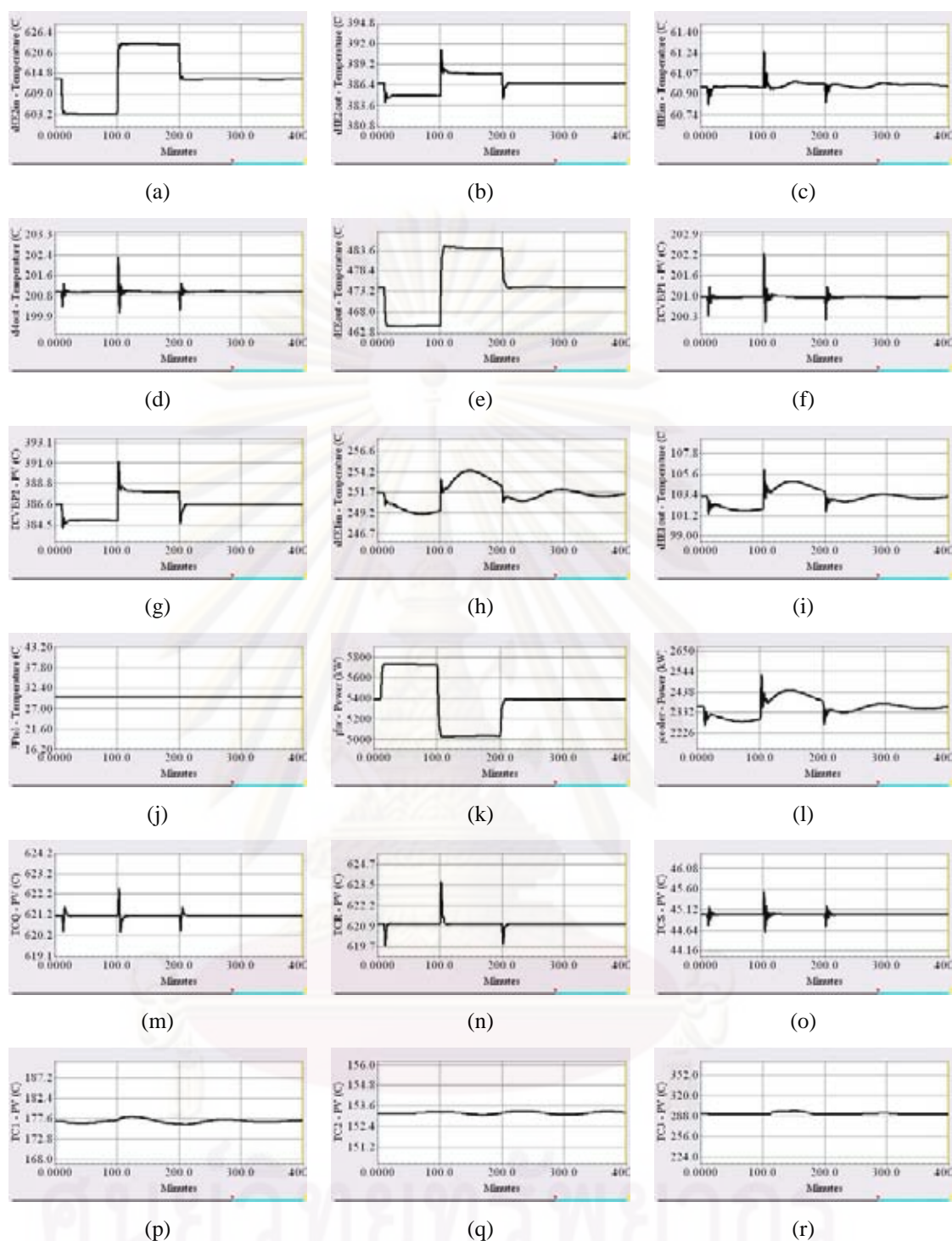

Figure 6.67 Dynamic responses of the HDA process HIP5.2 to a change in the heat load disturbance of hot stream (reactor product stream): CS₂, where: (a) FEHE2 hot inlet temperature, (b) FEHE2 hot outlet temperature, (c) FEHE1 cold inlet temperature, (d) FEHE2 cold inlet temperature, (e) FEHE2 cold outlet temperature, (f) FEHE1 bypass stream, (g) FEHE2 bypass stream, (h) FEHE1 hot inlet temperature, (i) FEHE1 hot outlet temperature, (j) fresh feed toluene temperature (k) furnace duty, (l) cooler duty, (m) quench temperature, (n) reactor inlet temperature, (o) separator temperature, (p) stabilizer column tray temperature, (q) product column tray temperature (r) recycle column tray temperature

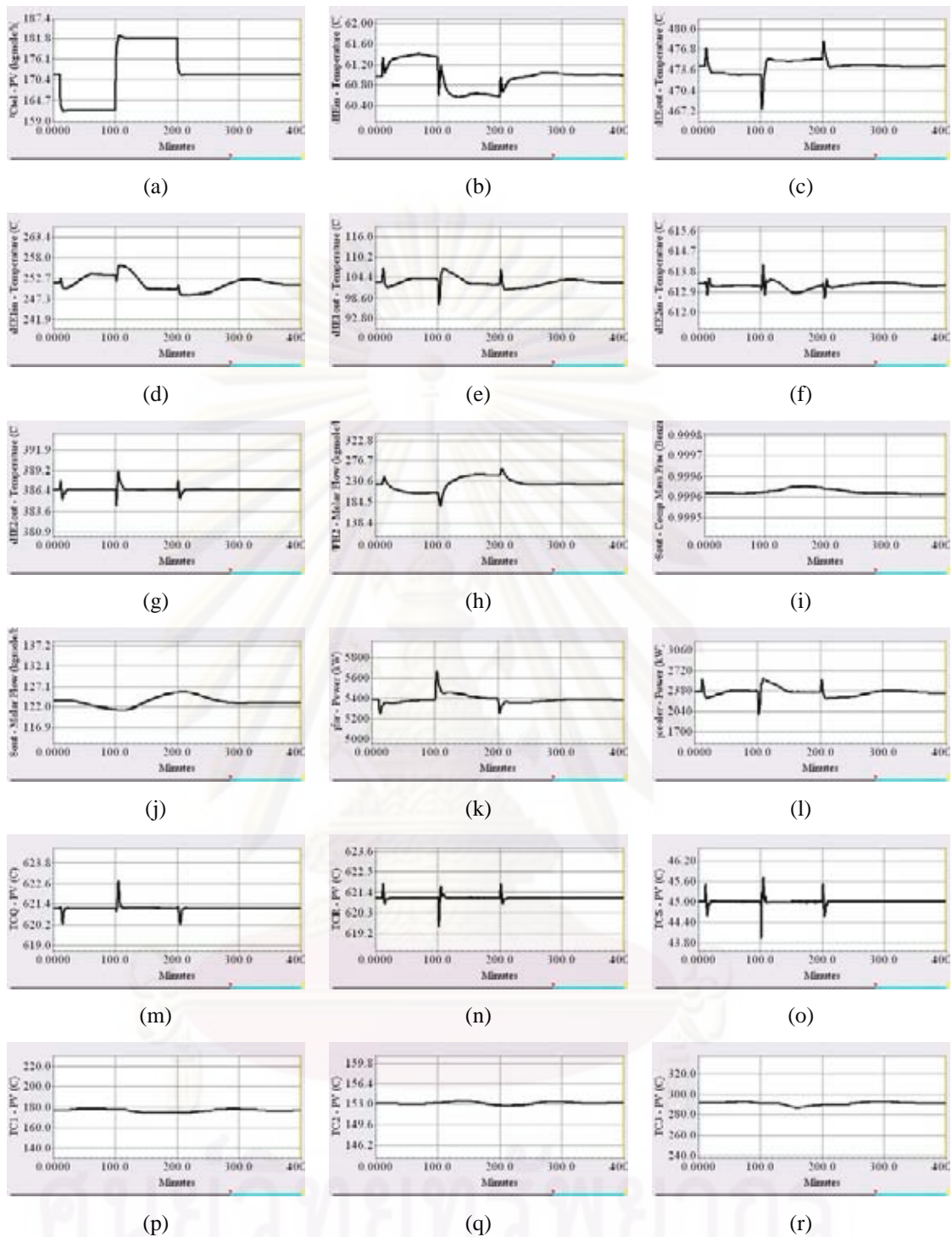

Figure 6.68 Dynamic responses of the HDA process HIP5.2 to a change in the total toluene feed flowrates: CS₂, where: (a) total toluene feed flowrates, (b) FEHE1 cold inlet temperature, (c) FEHE2 cold outlet temperature, (d) FEHE1 hot inlet temperature, (e) FEHE1 hot outlet temperature, (f) FEHE2 hot inlet temperature, (g) FEHE2 hot outlet temperature, (h) fresh feed hydrogen flowrates, (i) benzene purity, (j) benzene flowrate (k) furnace duty, (l) cooler duty, (m) quench temperature, (n) reactor inlet temperature, (o) separator temperature, (p) stabilizer column tray temperature, (q) product column tray temperature (r) recycle column tray temperature

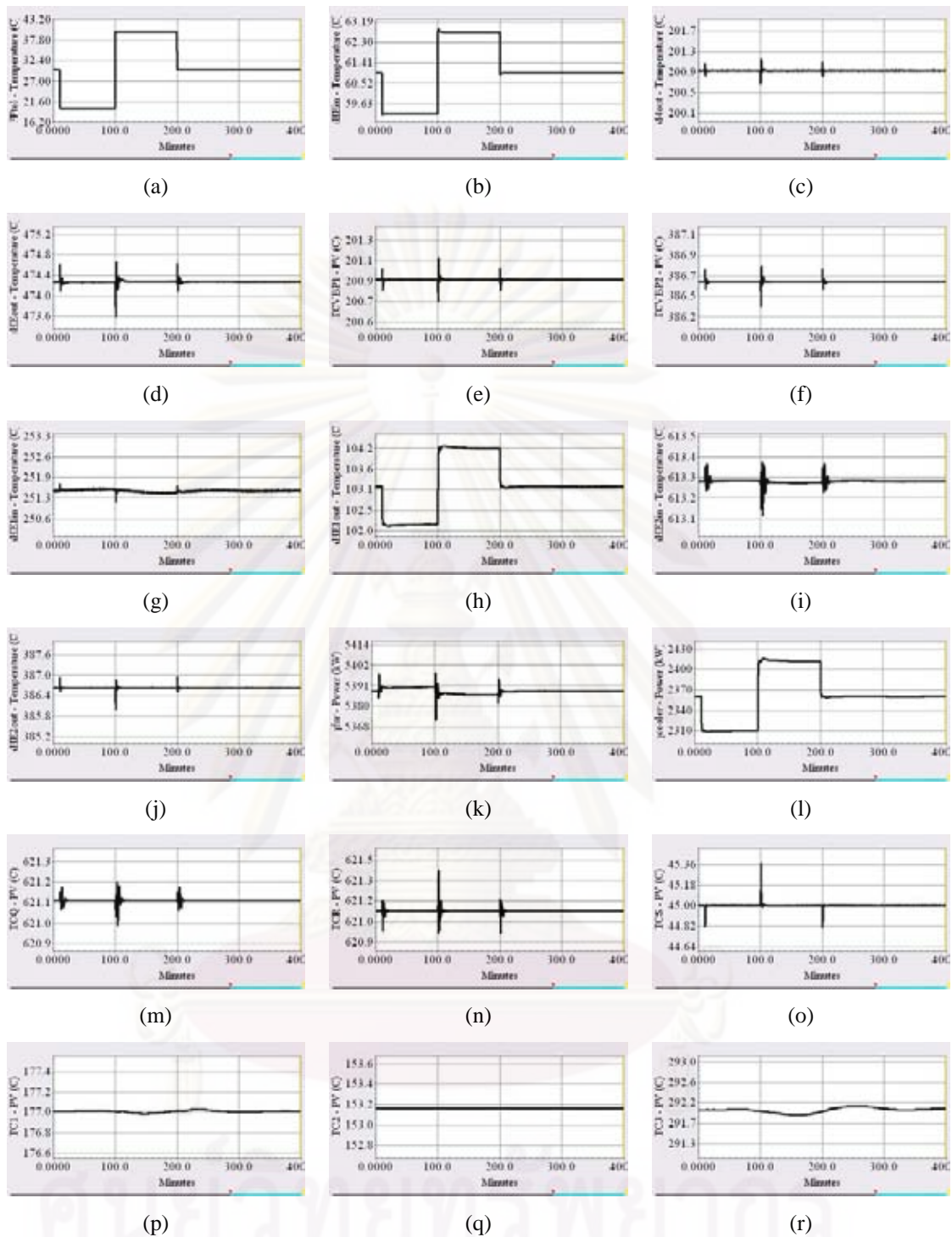

Figure 6.69 Dynamic responses of the HDA process HIP5.2 to a change in the heat load disturbance of cold stream (reactor feed stream): CS3, where: (a) fresh feed toluene temperature, (b) FEHE1 cold inlet temperature, (c) FEHE2 cold inlet temperature, (d) FEHE2 cold outlet temperature, (e) FEHE1 bypass stream, (f) FEHE2 bypass stream, (g) FEHE1 hot inlet temperature, (h) FEHE1 hot outlet temperature, (i) FEHE2 hot inlet temperature, (j) FEHE2 hot outlet temperature, (k) furnace duty, (l) cooler duty, (m) quench temperature, (n) reactor inlet temperature, (o) separator temperature, (p) stabilizer column tray temperature, (q) product column tray temperature (r) recycle column tray temperature

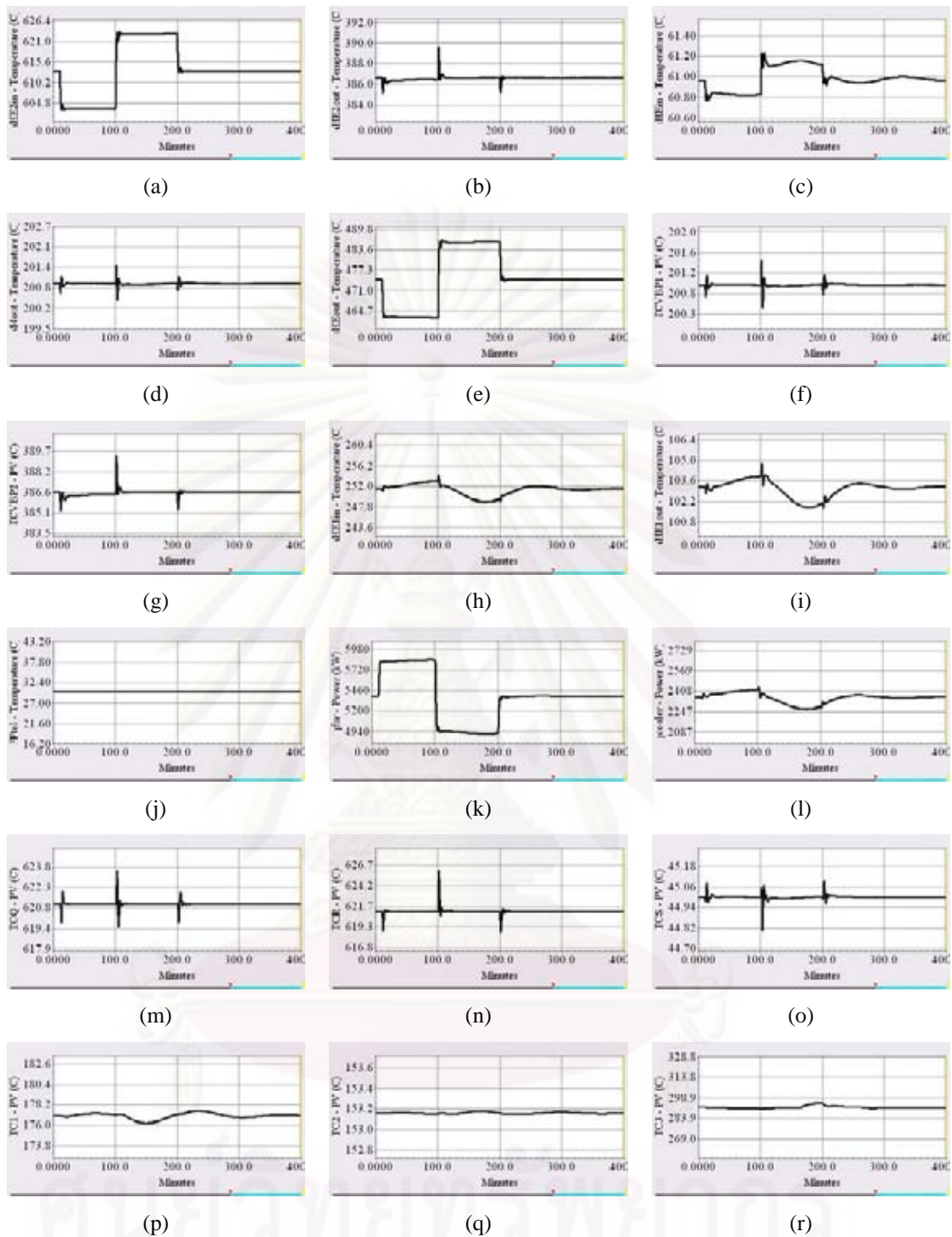

Figure 6.70 Dynamic responses of the HDA process HIP5.2 to a change in the heat load disturbance of hot stream (reactor product stream): CS3, where: (a) FEHE2 hot inlet temperature, (b) FEHE2 hot outlet temperature, (c) FEHE1 cold inlet temperature, (d) FEHE2 cold inlet temperature, (e) FEHE2 cold outlet temperature, (f) FEHE1 bypass stream, (g) FEHE2 bypass stream, (h) FEHE1 hot inlet temperature, (i) FEHE1 hot outlet temperature, (j) fresh feed toluene temperature (k) furnace duty, (l) cooler duty, (m) quench temperature, (n) reactor inlet temperature, (o) separator temperature, (p) stabilizer column tray temperature, (q) product column tray temperature (r) recycle column tray temperature

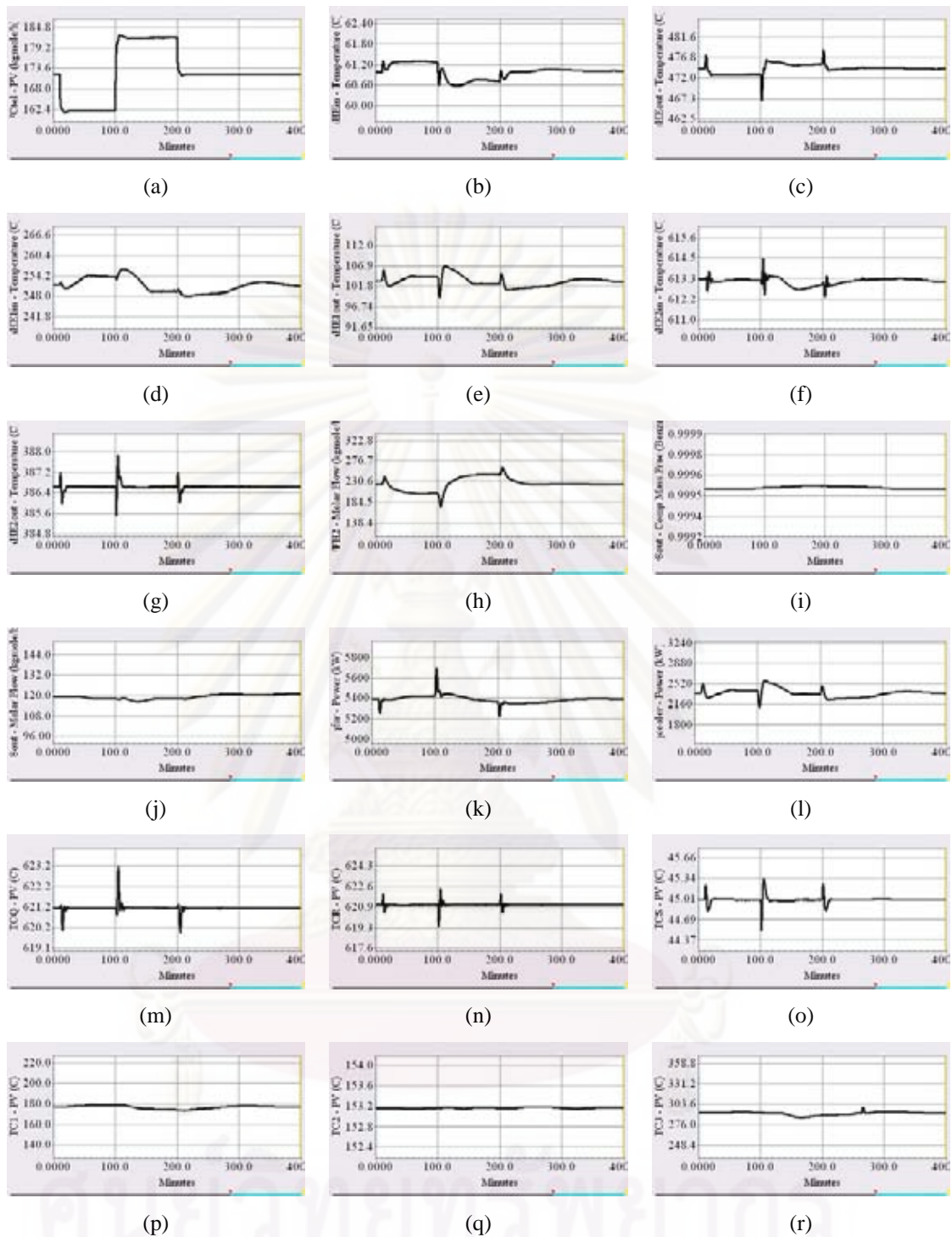

Figure 6.71 Dynamic responses of the HDA process HIP5.2 to a change in the total toluene feed flowrates: CS3, where: (a) total toluene feed flowrates, (b) FEHE1 cold inlet temperature, (c) FEHE2 cold outlet temperature, (d) FEHE1 hot inlet temperature, (e) FEHE1 hot outlet temperature, (f) FEHE2 hot inlet temperature, (g) FEHE2 hot outlet temperature, (h) fresh feed hydrogen flowrates, (i) benzene purity, (j) benzene flowrate (k) furnace duty, (l) cooler duty, (m) quench temperature, (n) reactor inlet temperature, (o) separator temperature, (p) stabilizer column tray temperature, (q) product column tray temperature (r) recycle column tray temperature

6.6.2 Dynamic Simulation Results of Complex Heat-Integrated HDA Process HIP6.1, HIP6.2 and HIP6.3

Three disturbance loads are used to evaluate the dynamic performance of the new control structure (CS1, CS2 and CS3) for HDA process HIP6.1, HIP6.2 and HIP6.3.

6.6.2.1 Change the Heat Load Disturbance of Cold Streams (Reactor Feed Stream)

The dynamic responses of the control system of the complex heat-integrated HDA process HIP6.1 are shown in Figure 6.72, 6.75 and 6.78, for HIP6.2 are shown in Figure 6.81, 6.84 and 6.87, and for HIP6.3 are shown in Figure 6.90, 6.93 and 6.96. In order to make this disturbance, first the fresh toluene feed temperature is decreased from 30 to 20°C at time equals 10 minutes, and the temperature is increased from 20 to 40°C at time equals 100 minutes, then its temperature is returned to its nominal value of 30°C at time equals 200 minutes (see Figure 6.72.a, 6.75.a, 6.78.a, 6.81.a, 6.84.a, 6.87.a, 6.90, 6.93 and 6.96).

The three new control structures (CS1, CS2 and CS3) give the same result for shifting the thermal disturbance load in cold steam (reactor feed stream) to heater or cooler as follows. First, the cold inlet temperature of FEHE is decreased and then both the cold and hot outlet temperatures of FEHE decrease suddenly. In order to the hot outlet temperature is decreased to a desired condition, the control action to control the cold outlet temperature of FEHE. As a result, the cold and hot outlet temperature of FEHE rapidly drops to a new steady state value and the cooler duty decreases (see Figure 6.72.l, 6.75.l, 6.78.l, 6.81.l, 6.84.l, 6.87.l, 6.90l, 6.93l and 6.96.l). When the cold inlet temperature of FEHE increases, both the cold and hot outlet temperatures of FEHE increase. In order to the hot outlet temperature is increased to a desired condition, the control action to control the cold outlet temperature of FEHE. As a result, the cold and hot outlet temperature of FEHE quickly increases to a new steady state value and the furnace duty decreases (see Figure 6.72.k, 6.75.k, 6.78.k, 6.81.k, 6.84.k, 6.87.k, 6.90.k, 6.93.k and 6.96.k).

As can be seen, this disturbance load has a little bit effect to the tray temperature in stabilizer column, product column and recycle columns however the three new control structures can control the tray temperature in three distillation columns slightly well. The reactor inlet temperature, the quench temperature, the separator temperature are slightly well controlled but the dynamic response of CS1 is smoother than CS2 and CS3.

6.6.2.2 Change the Heat Load Disturbance of Hot Streams (Reactor Product Stream)

The dynamic responses of the control system of the complex heat-integrated HDA process HIP6.1 are shown in Figure 6.73, 6.76 and 6.79, for HIP6.2 are shown in Figure 6.82, 6.85 and 6.88, and for HIP6.3 are shown in Figure 6.91, 6.94 and 6.97. This disturbance is made as follows: first the set point of FEHE-hot-inlet temperature controller (i.e. TCX1) is decreased from 621.1 to 611.1°C at time equals 10 minutes and the temperature is increased from 611.1 to 631.1°C at time equals 100 minutes, then its temperature is returned to its nominal value of 621.1°C at time equals 200 minutes (see Figure 6.73.a, 6.76.a, 6.79.a, 6.82.a, 6.85.a, 6.88.a, 6.91.a, 6.94.a and 6.97.a). As can be seen, this temperature response is very fast, the new steady state is reached quickly

Since the hot outlet temperature of FEHE is controlled to prevent the propagation of the thermal disturbance, both the positive and negative disturbance loads of the hot stream are shifted to the furnace utility. The cooler duty will be decreased in this case. Consider the case when the hot inlet temperature of FEHE increases, this is a desired condition to shift the disturbance load to the cold stream. Therefore, the cooler duty increases to a new steady state value.

For the tray temperatures in the stabilizer, product and recycle columns are slightly well controlled but CS2 is more oscillation than CS1 and CS3. The reactor inlet temperature, the quench temperature, the separator temperature are slightly well controlled but the dynamic response of CS1 is smoother than CS2 and CS3.

6.6.2.3 Change the Total Toluene Feed Flowrates

The dynamic responses of the control system of the complex heat-integrated HDA process HIP6.1 are shown in Figure 6.74, 6.77 and 6.80, for HIP6.2 are shown in Figure 6.83, 6.86 and 6.89, and for HIP6.3 are shown in Figure 6.92, 6.95 and 6.98. This disturbance is made by decreasing toluene flowrates from 172.3 to 162.3 kgmole/h at time equals 10 minutes, and the flowrates is increased from 162.3 to 182.3 kgmole/h at time equals 100 minutes, then its flowrates is returned to its nominal value of 172.3 kgmole/h at time equals 200 minutes (see Figure 6.74.a, 6.77.a, 6.80.a, 6.83.a, 6.86.a, 6.89.a, 6.92.a, 6.95.a and 6.98.a).

The dynamic result can be seen that the drop in total toluene feed flowrates reduces the reaction rate, so fresh feed hydrogen flowrates (see Figure 6.74.h, 6.77.h, 6.80.h, 6.83.h, 6.86.h, 6.89.h, 6.92.h, 6.95.h and 6.98.h), the benzene product flowrates drops (see Figure 6.74.j, 6.77.j, 6.80.j, 6.83.j, 6.86.j, 6.89.j, 6.92.j, 6.95.j and 6.98.j) and the benzene product quality is shown in Figure 6.74.i, 6.77.i, 6.80.i, 6.83.i, 6.86.i, 6.89.i, 6.92.i, 6.95.i and 6.98.i. Consider the case when the total toluene feed flowrates increase and the benzene product flowrates increase because of the reaction rate enlargement. The deviation of benzene product quality from nominal value in CS1, CS2 and CS3 are slightly similar when total toluene feed flowrates change.

As can be see, this disturbance has height effect to tray temperatures in the tray temperatures in the stabilizer, product and recycle columns however all control structure can the tray temperatures in the three columns slightly well.

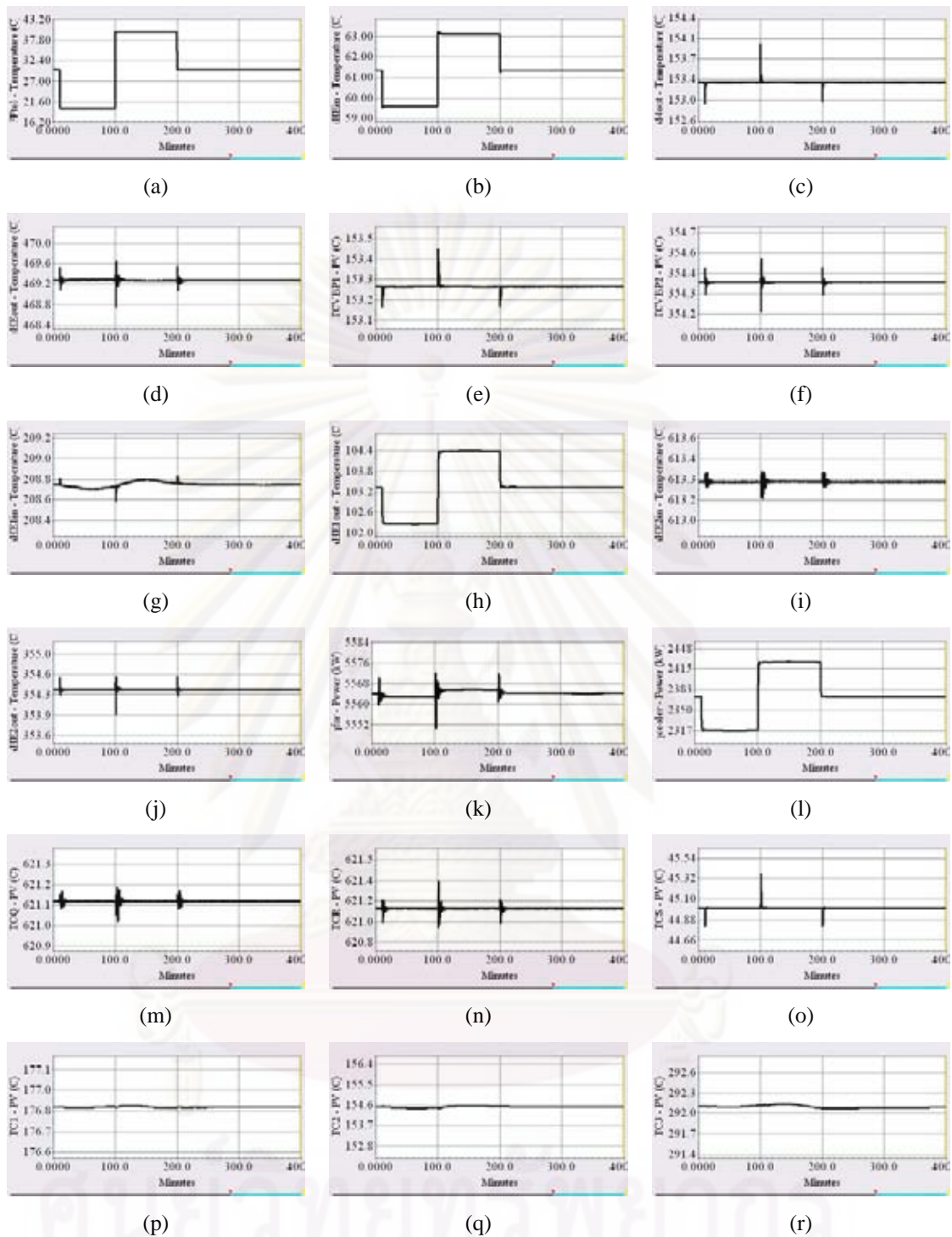

Figure 6.72 Dynamic responses of the HDA process HIP6.1 to a change in the heat load disturbance of cold stream (reactor feed stream): CS1, where: (a) fresh feed toluene temperature, (b) FEHE1 cold inlet temperature, (c) FEHE2 cold inlet temperature, (d) FEHE2 cold outlet temperature, (e) FEHE1 bypass stream, (f) FEHE2 bypass stream, (g) FEHE1 hot inlet temperature, (h) FEHE1 hot outlet temperature, (i) FEHE2 hot inlet temperature, (j) FEHE2 hot outlet temperature, (k) furnace duty, (l) cooler duty, (m) quench temperature, (n) reactor inlet temperature, (o) separator temperature, (p) stabilizer column tray temperature, (q) product column tray temperature (r) recycle column tray temperature

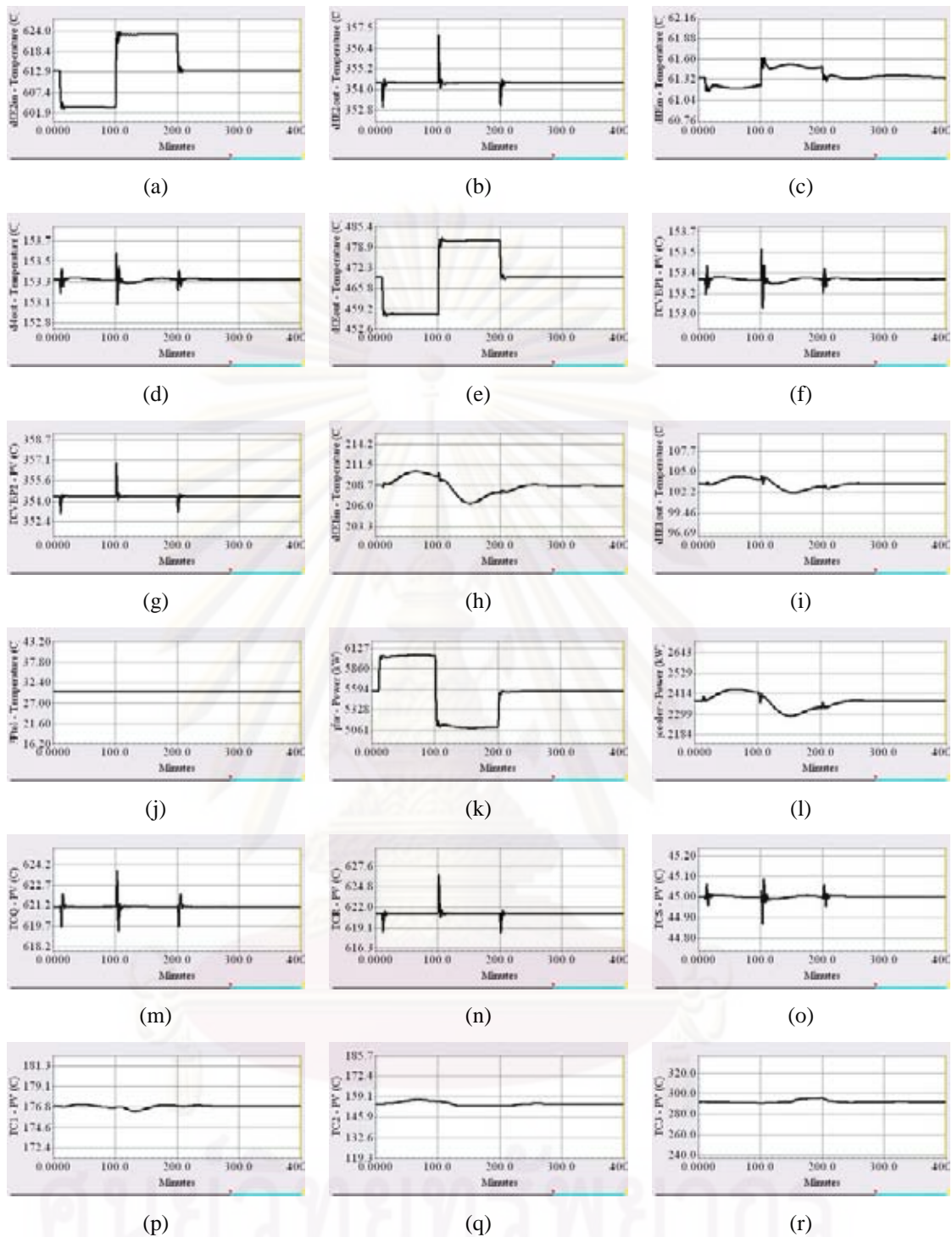

Figure 6.73 Dynamic responses of the HDA process HIP6.1 to a change in the heat load disturbance of hot stream (reactor product stream): CS1, where: (a) FEHE2 hot inlet temperature, (b) FEHE2 hot outlet temperature, (c) FEHE1 cold inlet temperature, (d) FEHE2 cold inlet temperature, (e) FEHE2 cold outlet temperature, (f) FEHE1 bypass stream, (g) FEHE2 bypass stream, (h) FEHE1 hot inlet temperature, (i) FEHE1 hot outlet temperature, (j) fresh feed toluene temperature (k) furnace duty, (l) cooler duty, (m) quench temperature, (n) reactor inlet temperature, (o) separator temperature, (p) stabilizer column tray temperature, (q) product column tray temperature (r) recycle column tray temperature

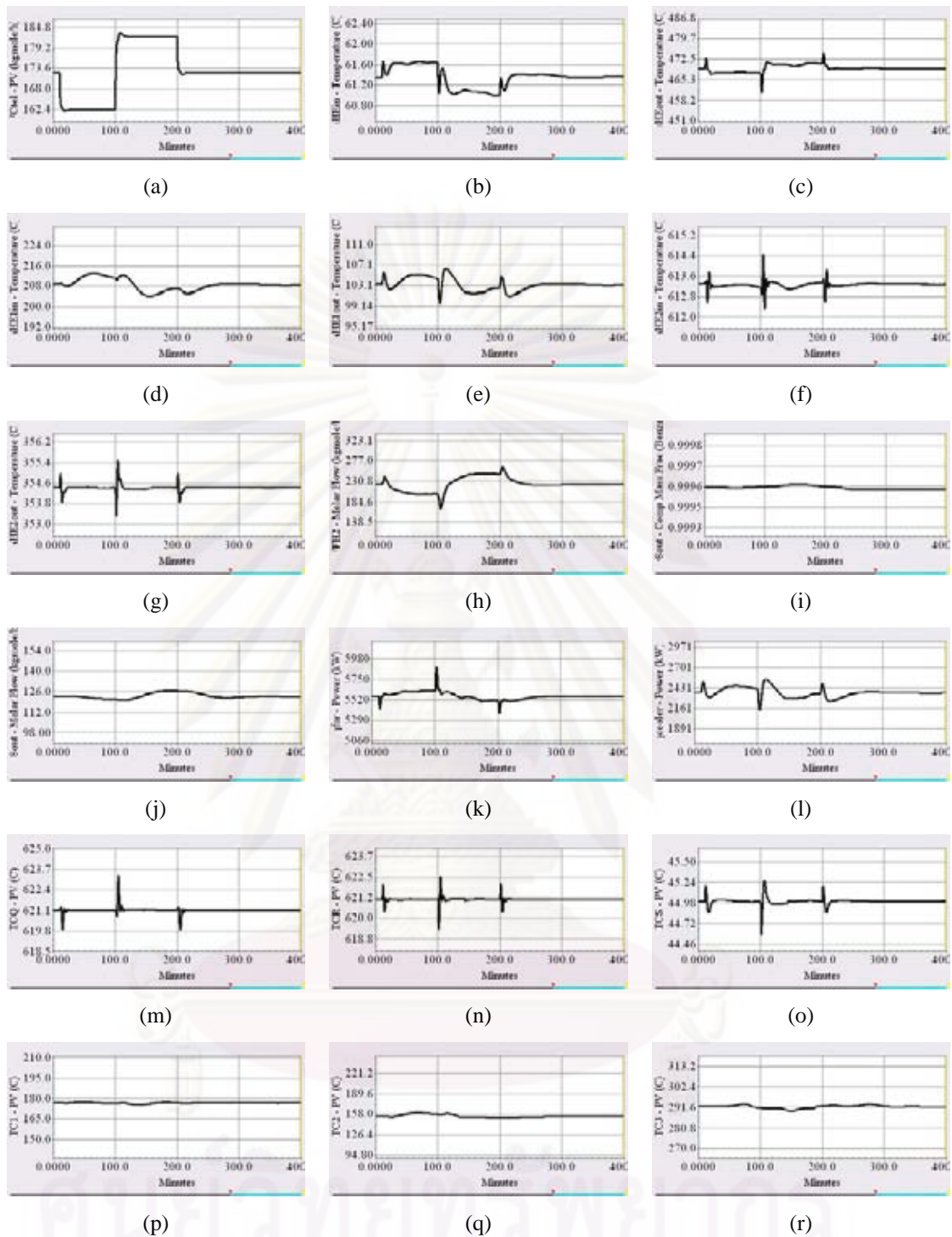

Figure 6.74 Dynamic responses of the HDA process HIP6.1 to a change in the total toluene feed flowrates: CS1, where: (a) total toluene feed flowrates, (b) FEHE1 cold inlet temperature, (c) FEHE2 cold outlet temperature, (d) FEHE1 hot inlet temperature, (e) FEHE1 hot outlet temperature, (f) FEHE2 hot inlet temperature, (g) FEHE2 hot outlet temperature, (h) fresh feed hydrogen flowrates, (i) benzene purity, (j) benzene flowrate (k) furnace duty, (l) cooler duty, (m) quench temperature, (n) reactor inlet temperature, (o) separator temperature, (p) stabilizer column tray temperature, (q) product column tray temperature (r) recycle column tray temperature

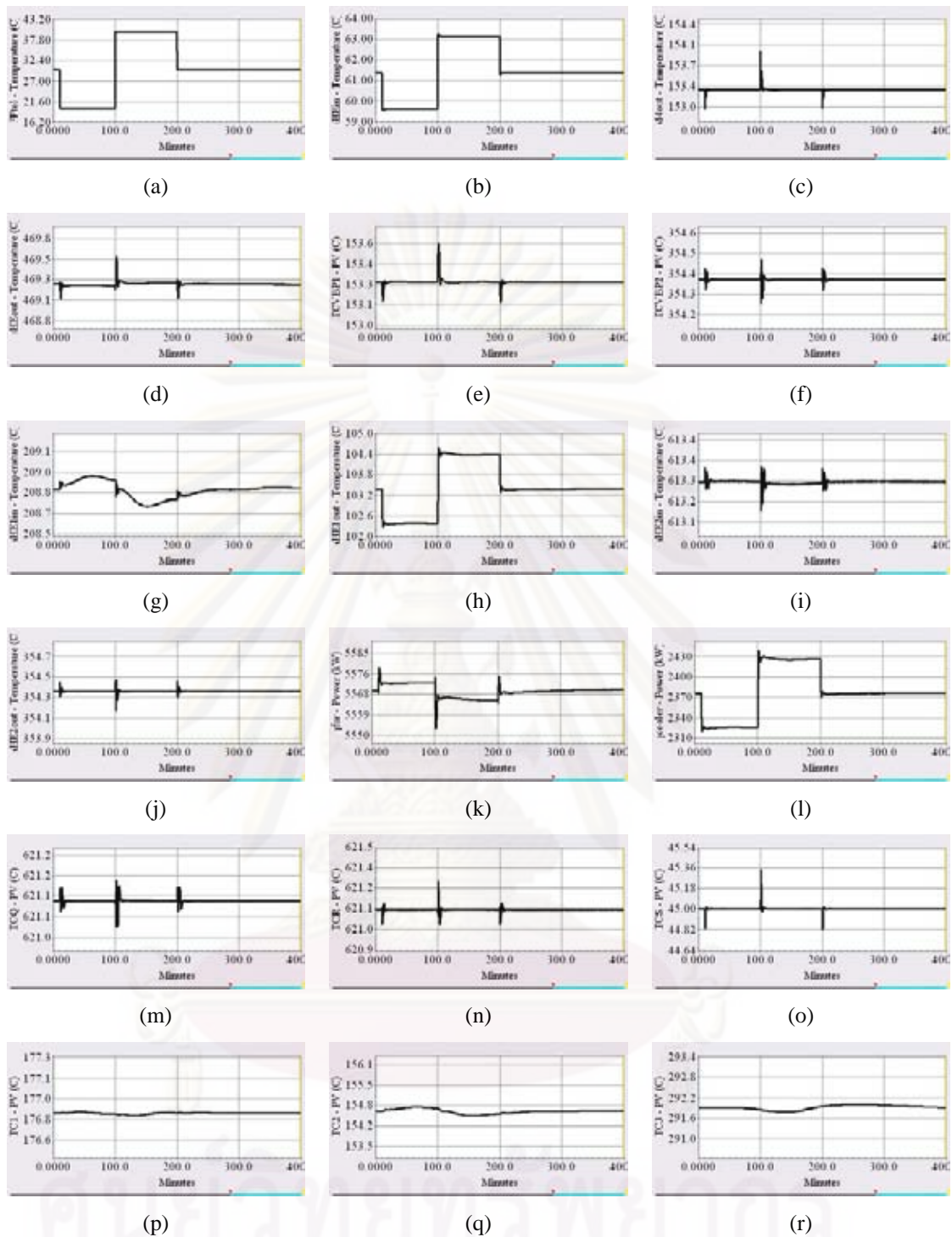

Figure 6.75 Dynamic responses of the HDA process HIP6.1 to a change in the heat load disturbance of cold stream (reactor feed stream): CS2, where: (a) fresh feed toluene temperature, (b) FEHE1 cold inlet temperature, (c) FEHE2 cold inlet temperature, (d) FEHE2 cold outlet temperature, (e) FEHE1 bypass stream, (f) FEHE2 bypass stream, (g) FEHE1 hot inlet temperature, (h) FEHE1 hot outlet temperature, (i) FEHE2 hot inlet temperature, (j) FEHE2 hot outlet temperature, (k) furnace duty, (l) cooler duty, (m) quench temperature, (n) reactor inlet temperature, (o) separator temperature, (p) stabilizer column tray temperature, (q) product column tray temperature (r) recycle column tray temperature

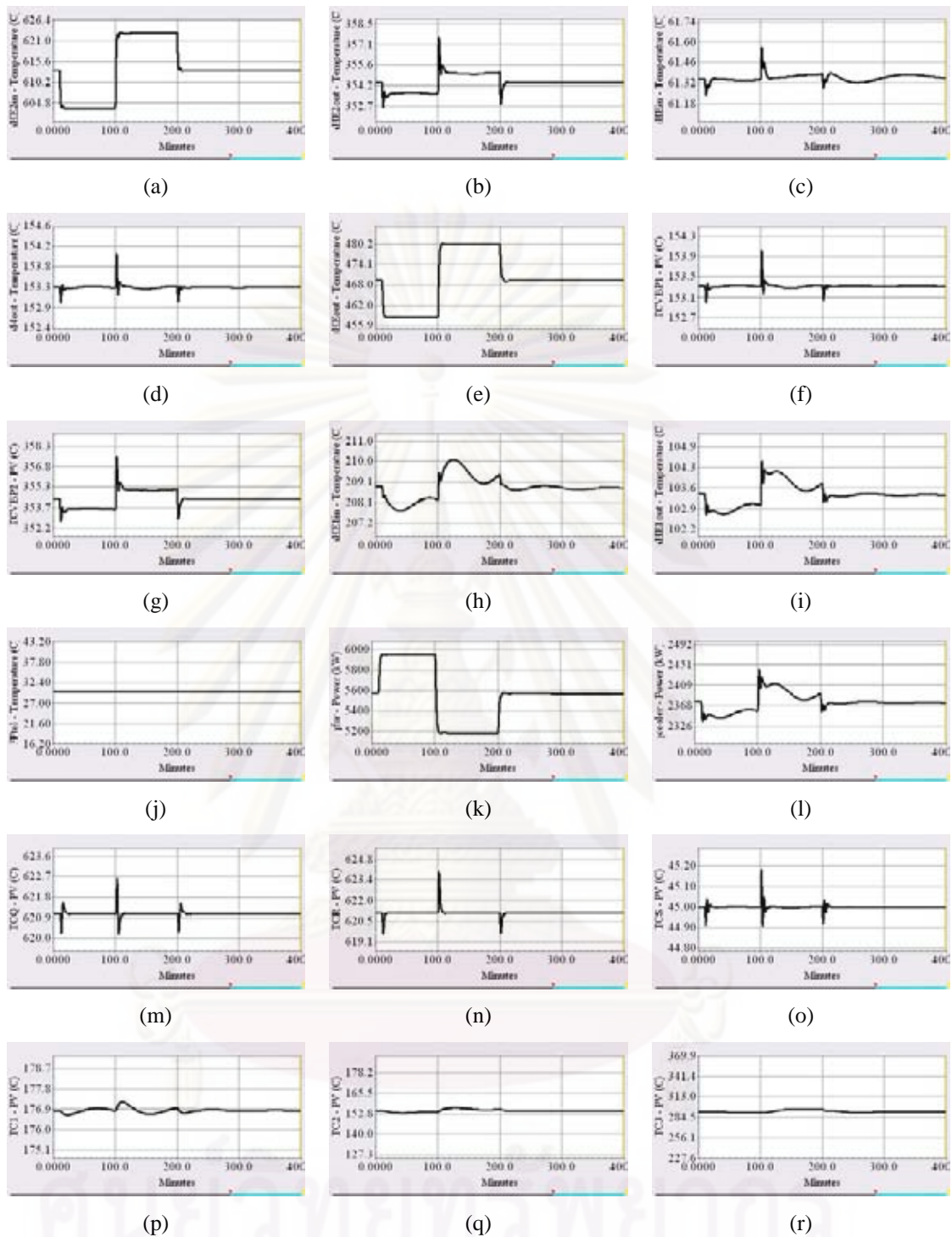

Figure 6.76 Dynamic responses of the HDA process HIP6.1 to a change in the heat load disturbance of hot stream (reactor product stream): CS₂, where: (a) FEHE2 hot inlet temperature, (b) FEHE2 hot outlet temperature, (c) FEHE1 cold inlet temperature, (d) FEHE2 cold inlet temperature, (e) FEHE2 cold outlet temperature, (f) FEHE1 bypass stream, (g) FEHE2 bypass stream, (h) FEHE1 hot inlet temperature, (i) FEHE1 hot outlet temperature, (j) fresh feed toluene temperature (k) furnace duty, (l) cooler duty, (m) quench temperature, (n) reactor inlet temperature, (o) separator temperature, (p) stabilizer column tray temperature, (q) product column tray temperature (r) recycle column tray temperature

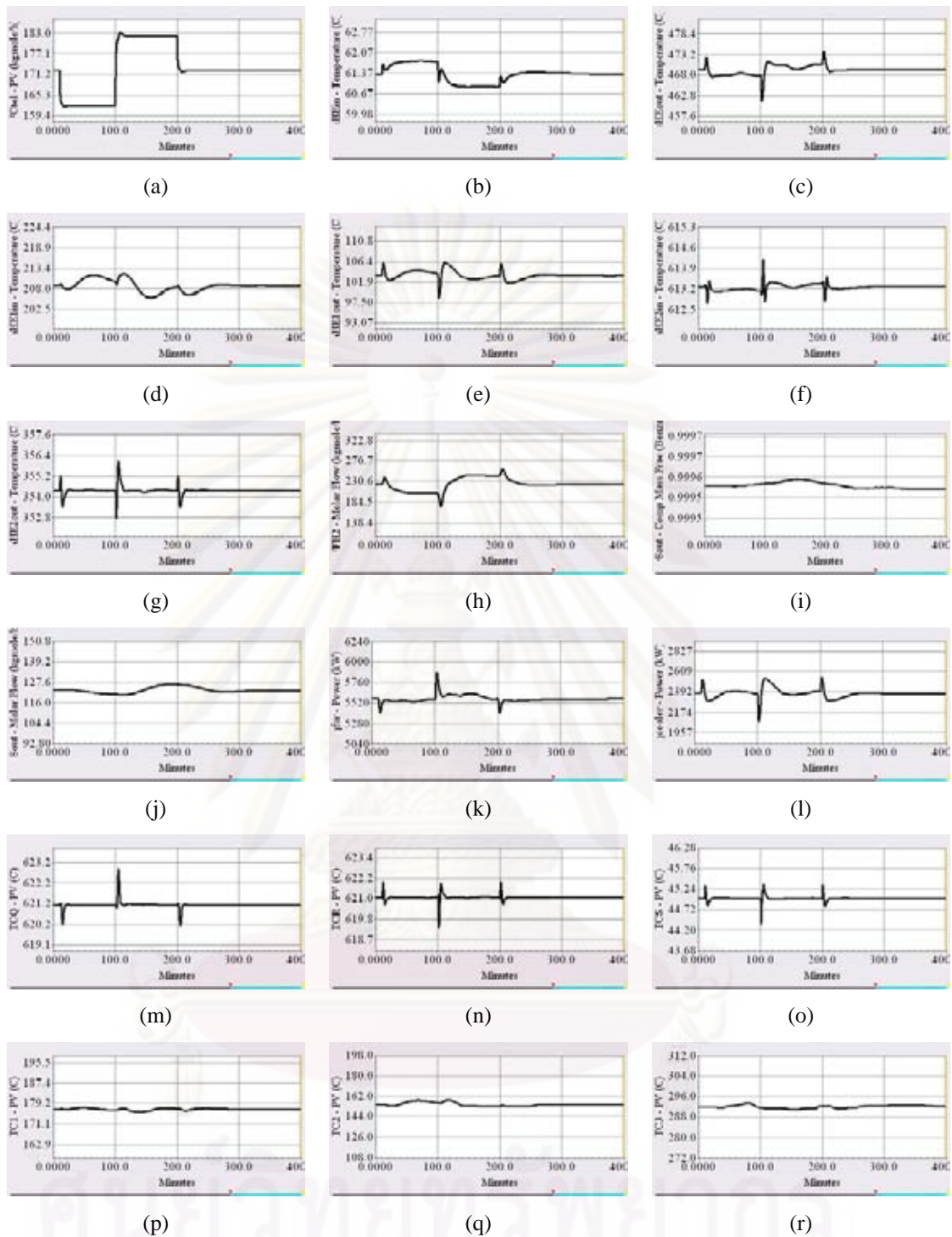

Figure 6.77 Dynamic responses of the HDA process HIP6.1 to a change in the total toluene feed flowrates: CS₂, where: (a) total toluene feed flowrates, (b) FEHE1 cold inlet temperature, (c) FEHE2 cold outlet temperature, (d) FEHE1 hot inlet temperature, (e) FEHE1 hot outlet temperature, (f) FEHE2 hot inlet temperature, (g) FEHE2 hot outlet temperature, (h) fresh feed hydrogen flowrates, (i) benzene purity, (j) benzene flowrate (k) furnace duty, (l) cooler duty, (m) quench temperature, (n) reactor inlet temperature, (o) separator temperature, (p) stabilizer column tray temperature, (q) product column tray temperature (r) recycle column tray temperature

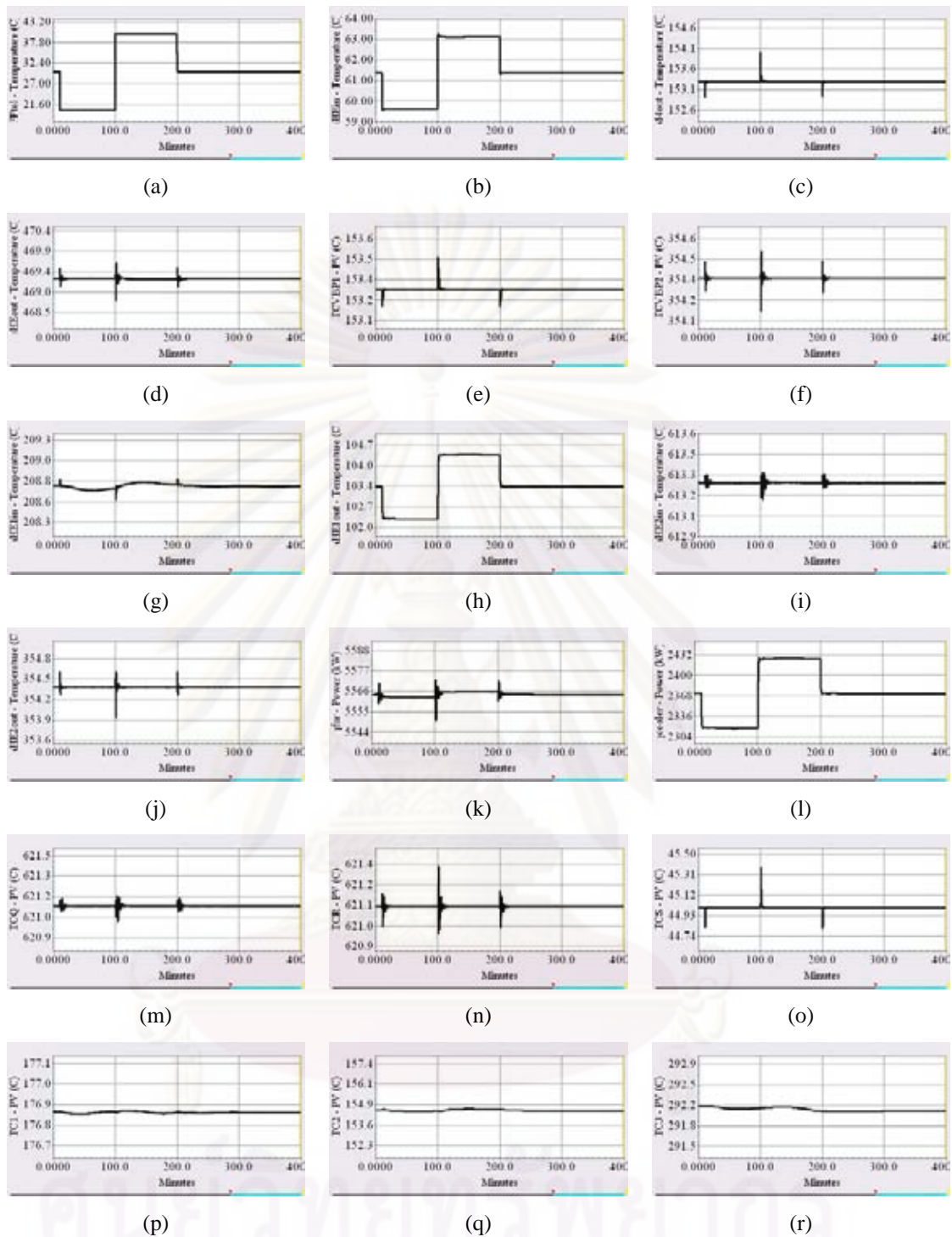

Figure 6.78 Dynamic responses of the HDA process HIP6.1 to a change in the heat load disturbance of cold stream (reactor feed stream): CS3, where: (a) fresh feed toluene temperature, (b) FEHE1 cold inlet temperature, (c) FEHE2 cold inlet temperature, (d) FEHE2 cold outlet temperature, (e) FEHE1 bypass stream, (f) FEHE2 bypass stream, (g) FEHE1 hot inlet temperature, (h) FEHE1 hot outlet temperature, (i) FEHE2 hot inlet temperature, (j) FEHE2 hot outlet temperature, (k) furnace duty, (l) cooler duty, (m) quench temperature, (n) reactor inlet temperature, (o) separator temperature, (p) stabilizer column tray temperature, (q) product column tray temperature (r) recycle column tray temperature

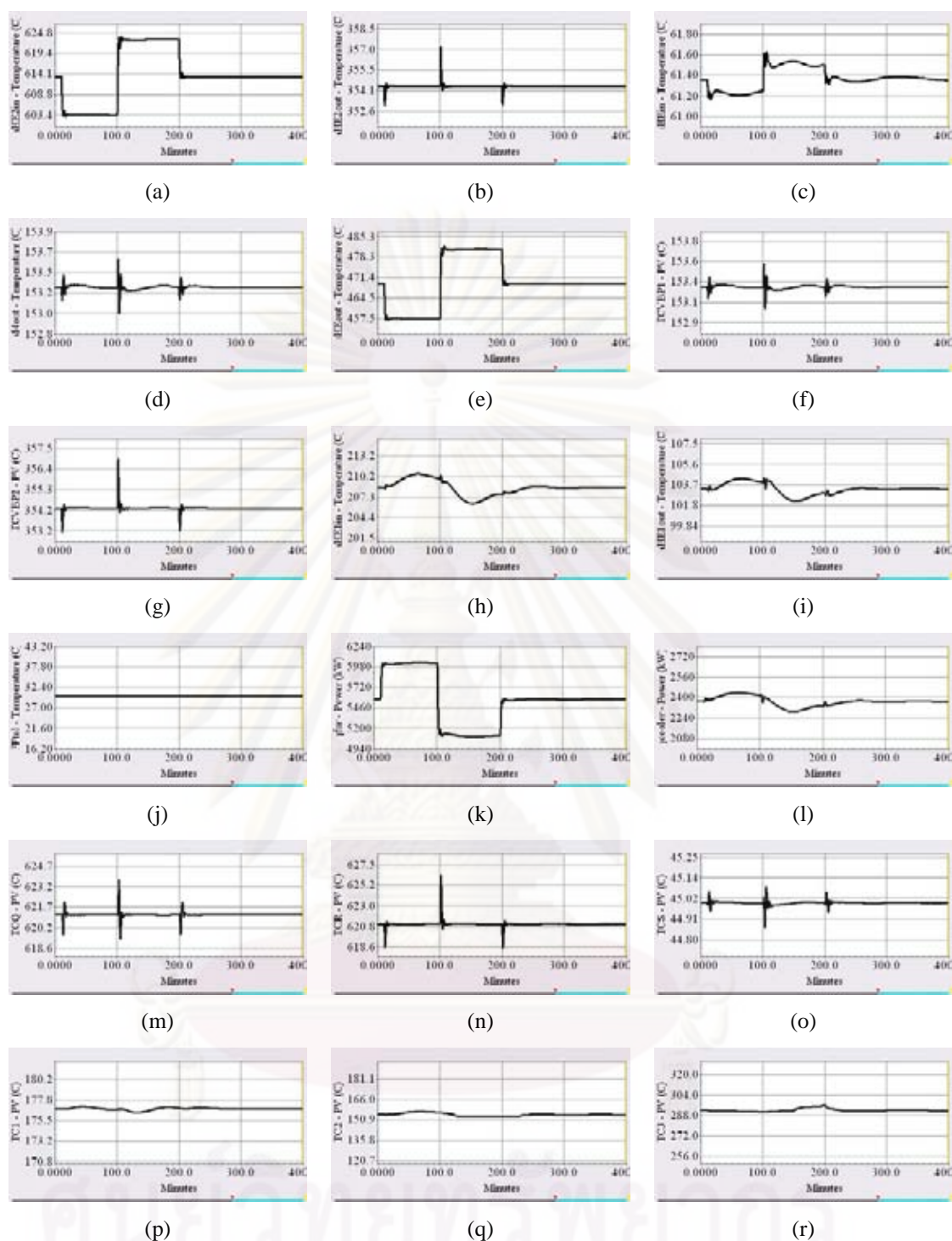

Figure 6.79 Dynamic responses of the HDA process HIP6.1 to a change in the heat load disturbance of hot stream (reactor product stream): CS3, where: (a) FEHE2 hot inlet temperature, (b) FEHE2 hot outlet temperature, (c) FEHE1 cold inlet temperature, (d) FEHE2 cold inlet temperature, (e) FEHE2 cold outlet temperature, (f) FEHE1 bypass stream, (g) FEHE2 bypass stream, (h) FEHE1 hot inlet temperature, (i) FEHE1 hot outlet temperature, (j) fresh feed toluene temperature (k) furnace duty, (l) cooler duty, (m) quench temperature, (n) reactor inlet temperature, (o) separator temperature, (p) stabilizer column tray temperature, (q) product column tray temperature (r) recycle column tray temperature

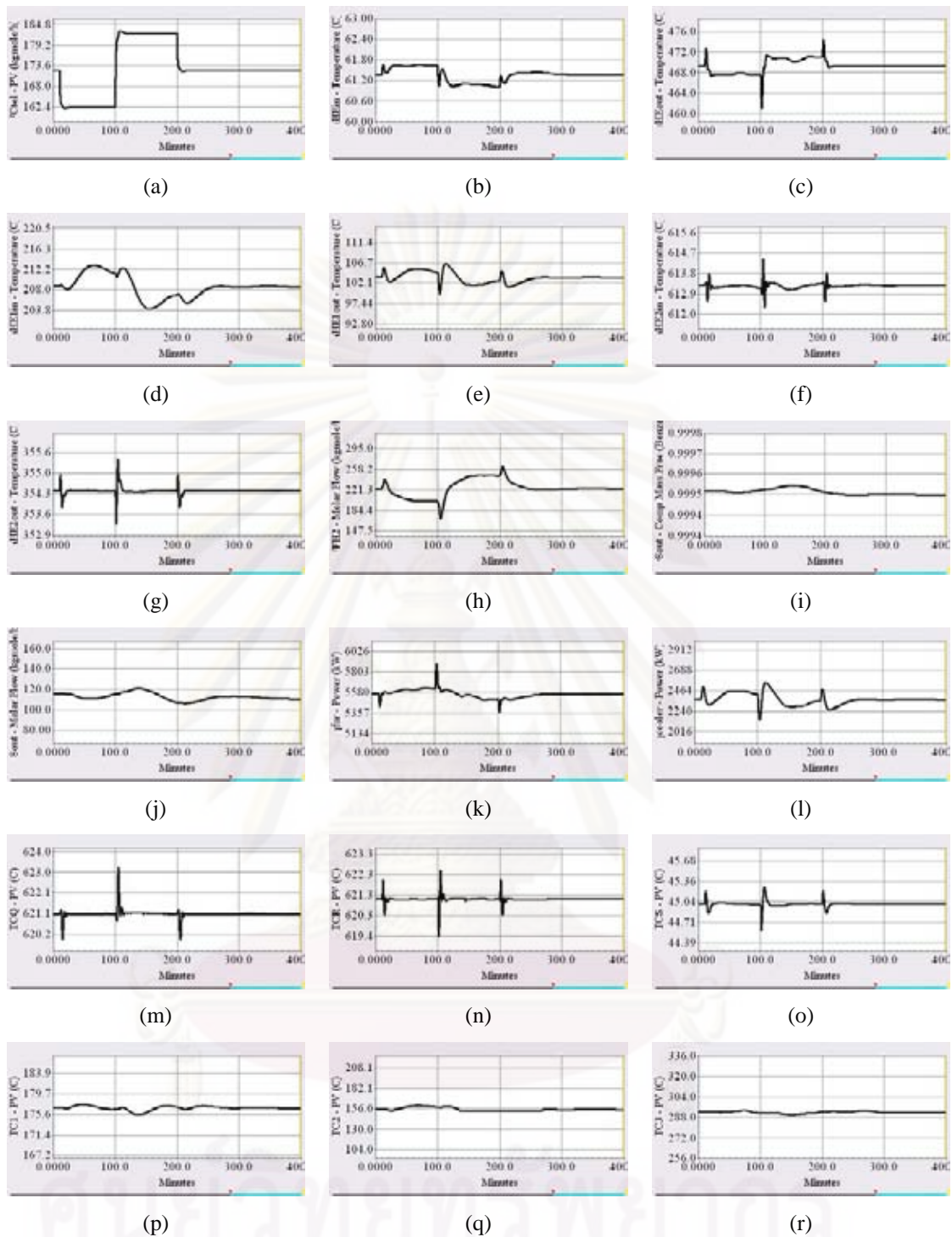

Figure 6.80 Dynamic responses of the HDA process HIP6.1 to a change in the total toluene feed flowrates: CS3, where: (a) total toluene feed flowrates, (b) FEHE1 cold inlet temperature, (c) FEHE2 cold outlet temperature, (d) FEHE1 hot inlet temperature, (e) FEHE1 hot outlet temperature, (f) FEHE2 hot inlet temperature, (g) FEHE2 hot outlet temperature, (h) fresh feed hydrogen flowrates, (i) benzene purity, (j) benzene flowrate (k) furnace duty, (l) cooler duty, (m) quench temperature, (n) reactor inlet temperature, (o) separator temperature, (p) stabilizer column tray temperature, (q) product column tray temperature (r) recycle column tray temperature

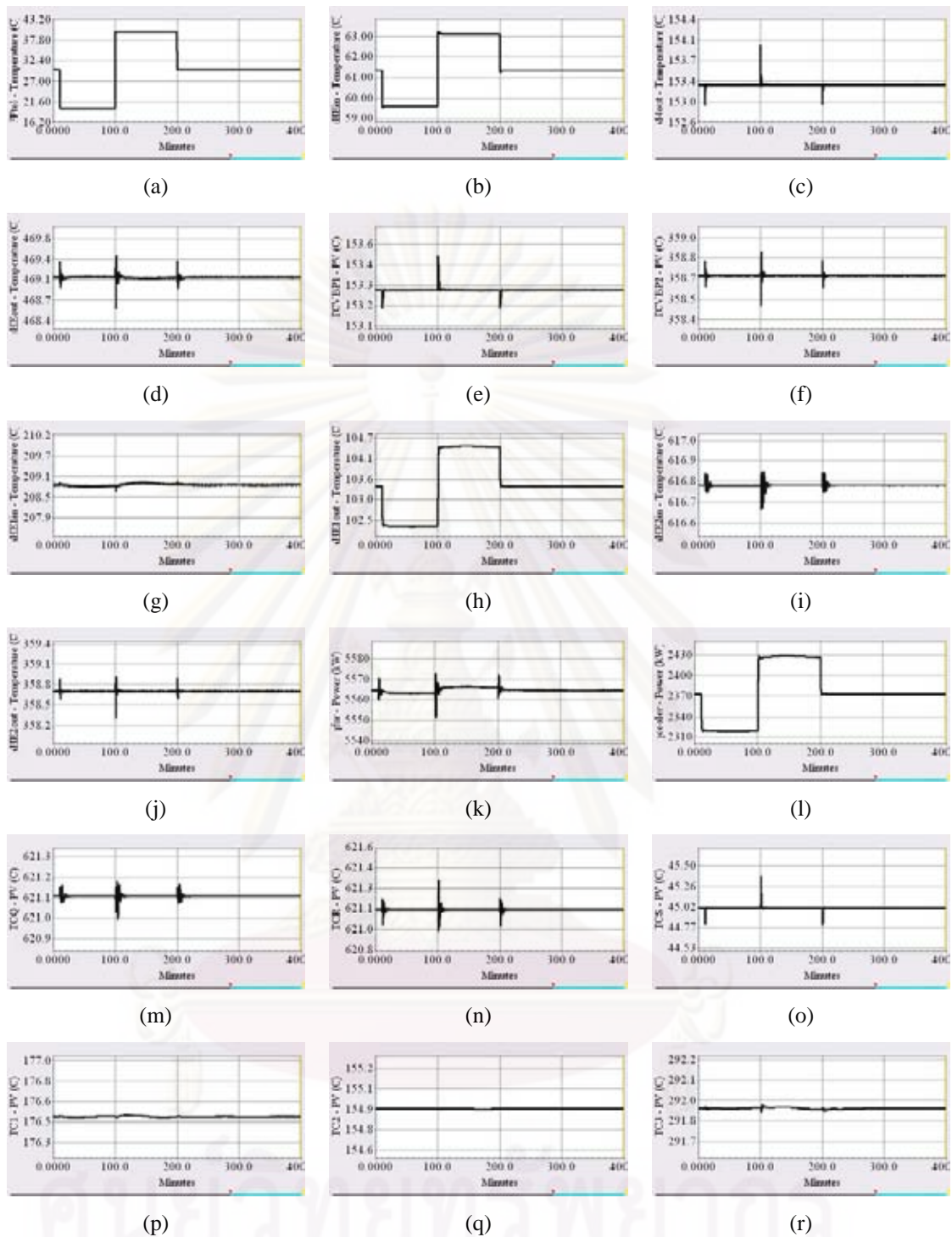

Figure 6.81 Dynamic responses of the HDA process HIP6.2 to a change in the heat load disturbance of cold stream (reactor feed stream): CS1, where: (a) fresh feed toluene temperature, (b) FEHE1 cold inlet temperature, (c) FEHE2 cold inlet temperature, (d) FEHE2 cold outlet temperature, (e) FEHE1 bypass stream, (f) FEHE2 bypass stream, (g) FEHE1 hot inlet temperature, (h) FEHE1 hot outlet temperature, (i) FEHE2 hot inlet temperature, (j) FEHE2 hot outlet temperature, (k) furnace duty, (l) cooler duty, (m) quench temperature, (n) reactor inlet temperature, (o) separator temperature, (p) stabilizer column tray temperature, (q) product column tray temperature (r) recycle column tray temperature

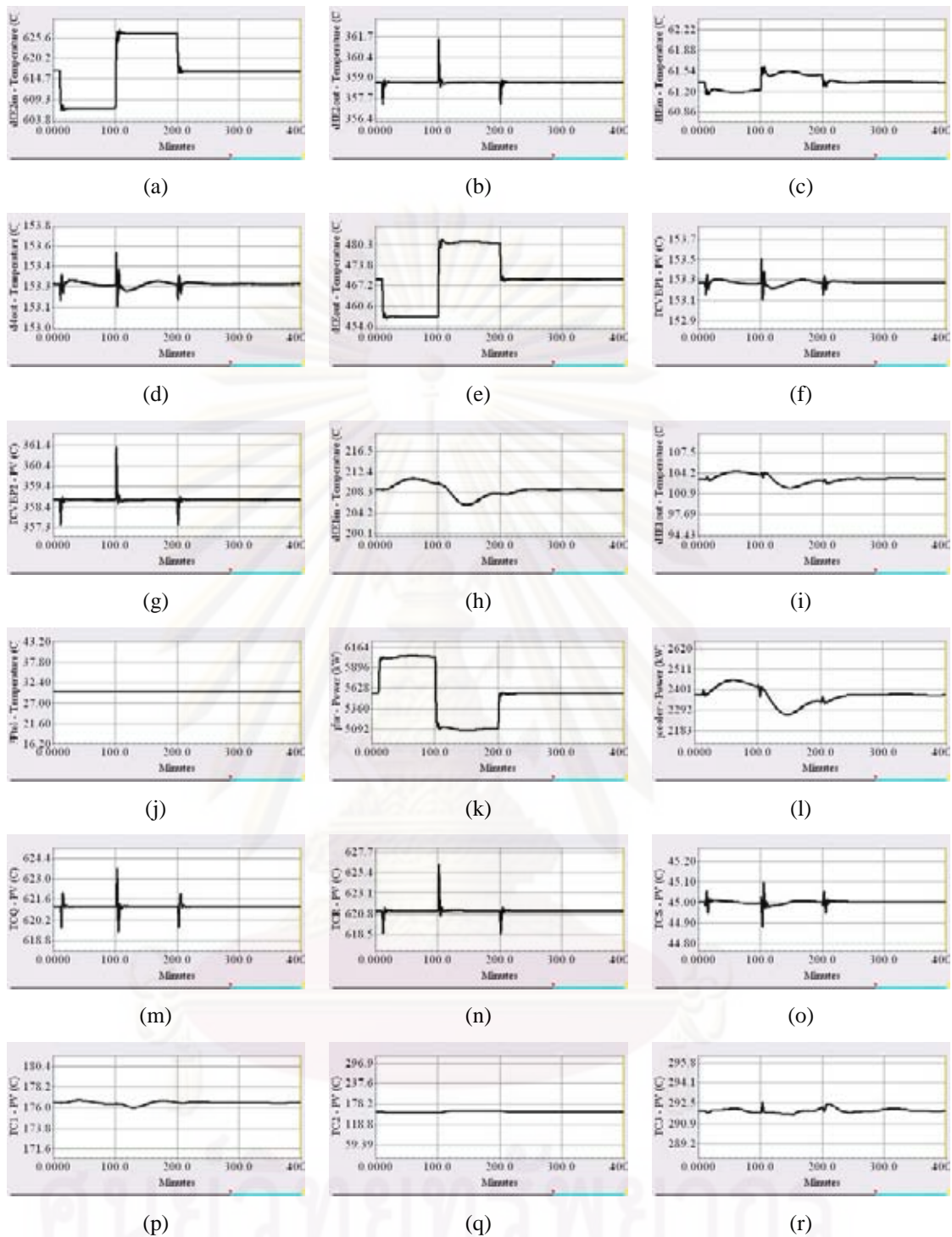

Figure 6.82 Dynamic responses of the HDA process HIP6.2 to a change in the heat load disturbance of hot stream (reactor product stream): CS1, where: (a) FEHE2 hot inlet temperature, (b) FEHE2 hot outlet temperature, (c) FEHE1 cold inlet temperature, (d) FEHE2 cold inlet temperature, (e) FEHE2 cold outlet temperature, (f) FEHE1 bypass stream, (g) FEHE2 bypass stream, (h) FEHE1 hot inlet temperature, (i) FEHE1 hot outlet temperature, (j) fresh feed toluene temperature (k) furnace duty, (l) cooler duty, (m) quench temperature, (n) reactor inlet temperature, (o) separator temperature, (p) stabilizer column tray temperature, (q) product column tray temperature (r) recycle column tray temperature

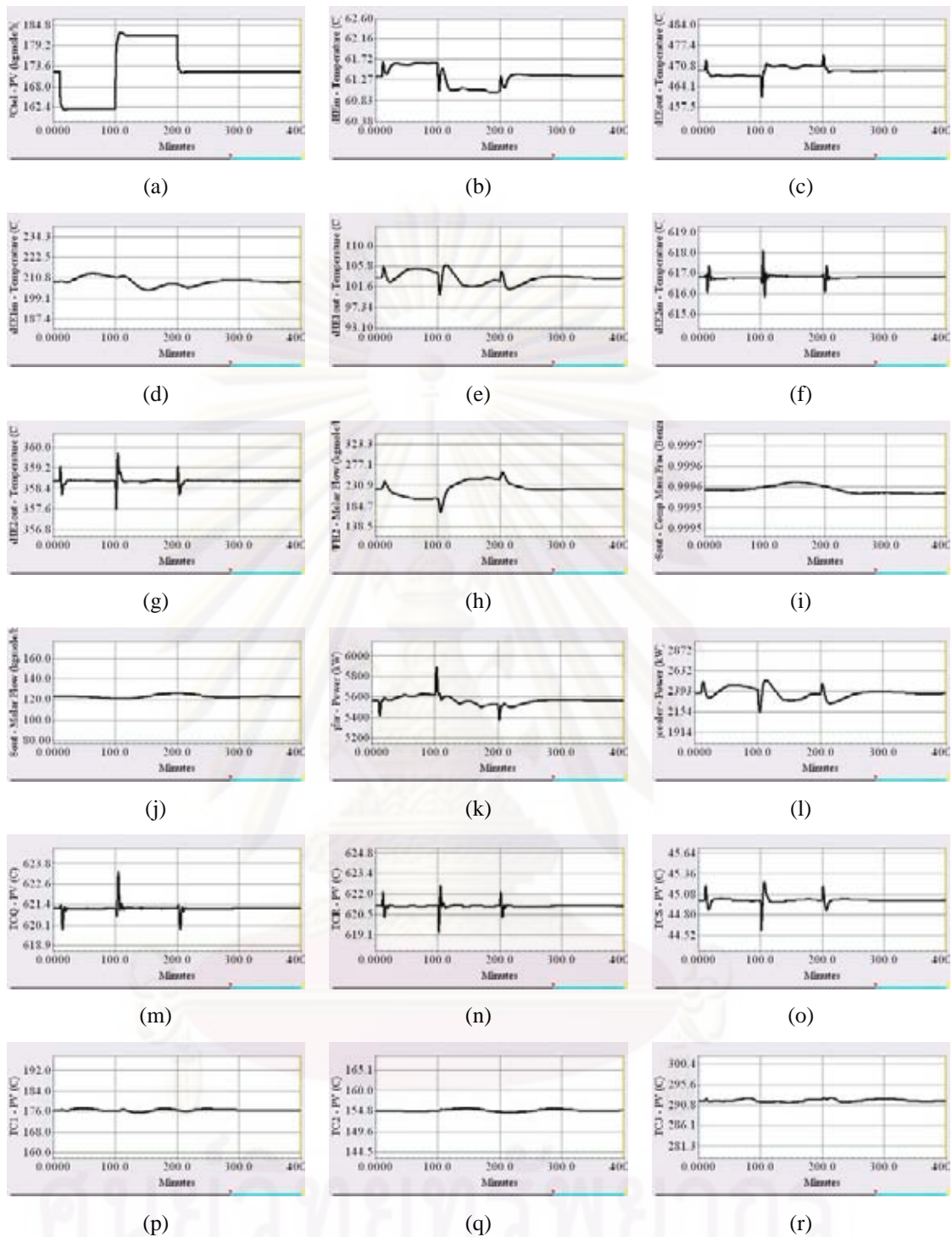

Figure 6.83 Dynamic responses of the HDA process HIP6.2 to a change in the total toluene feed flowrates: CS1, where: (a) total toluene feed flowrates, (b) FEHE1 cold inlet temperature, (c) FEHE2 cold outlet temperature, (d) FEHE1 hot inlet temperature, (e) FEHE1 hot outlet temperature, (f) FEHE2 hot inlet temperature, (g) FEHE2 hot outlet temperature, (h) fresh feed hydrogen flowrates, (i) benzene purity, (j) benzene flowrate (k) furnace duty, (l) cooler duty, (m) quench temperature, (n) reactor inlet temperature, (o) separator temperature, (p) stabilizer column tray temperature, (q) product column tray temperature (r) recycle column tray temperature

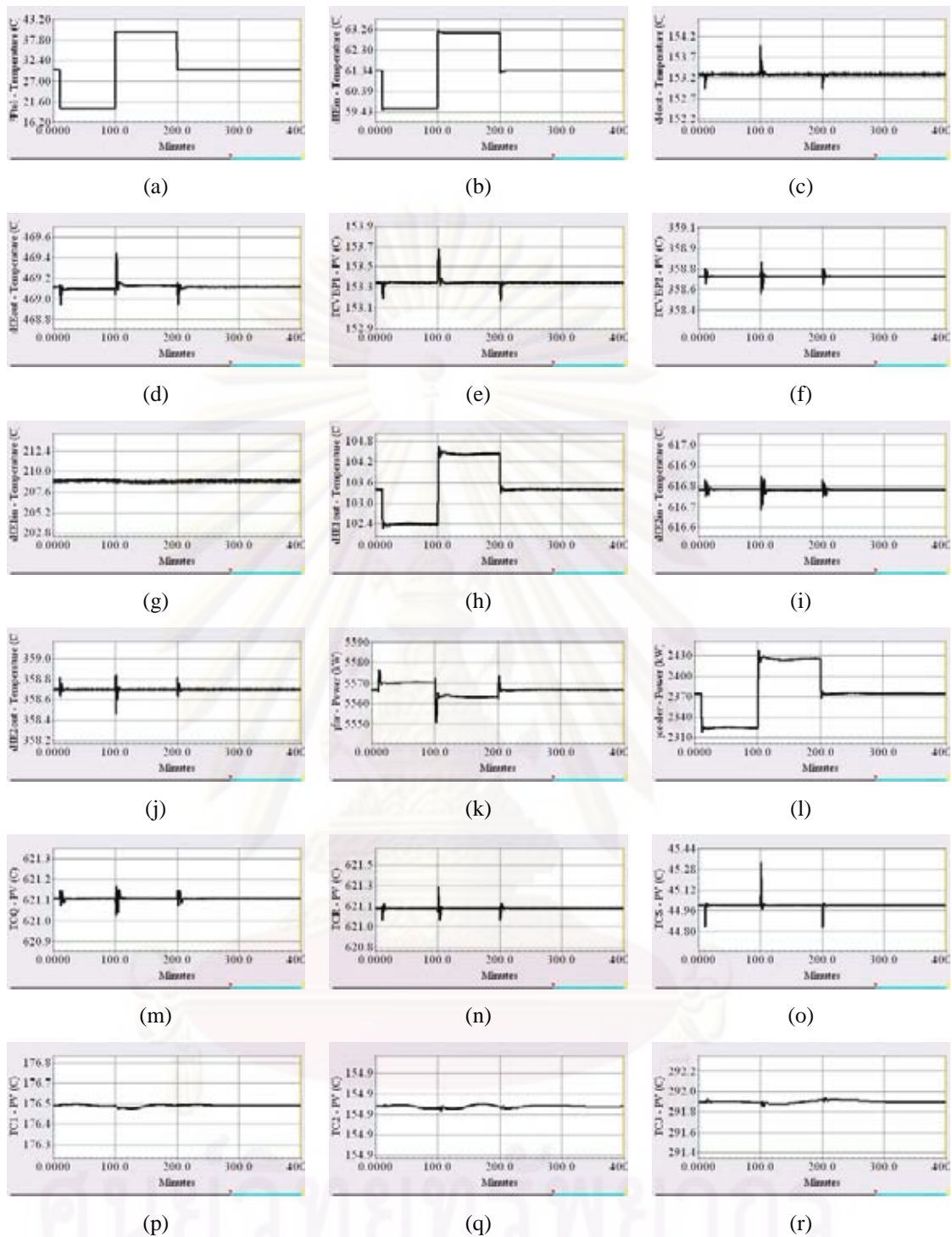

Figure 6.84 Dynamic responses of the HDA process HIP6.2 to a change in the heat load disturbance of cold stream (reactor feed stream): CS2, where: (a) fresh feed toluene temperature, (b) FEHE1 cold inlet temperature, (c) FEHE2 cold inlet temperature, (d) FEHE2 cold outlet temperature, (e) FEHE1 bypass stream, (f) FEHE2 bypass stream, (g) FEHE1 hot inlet temperature, (h) FEHE1 hot outlet temperature, (i) FEHE2 hot inlet temperature, (j) FEHE2 hot outlet temperature, (k) furnace duty, (l) cooler duty, (m) quench temperature, (n) reactor inlet temperature, (o) separator temperature, (p) stabilizer column tray temperature, (q) product column tray temperature (r) recycle column tray temperature

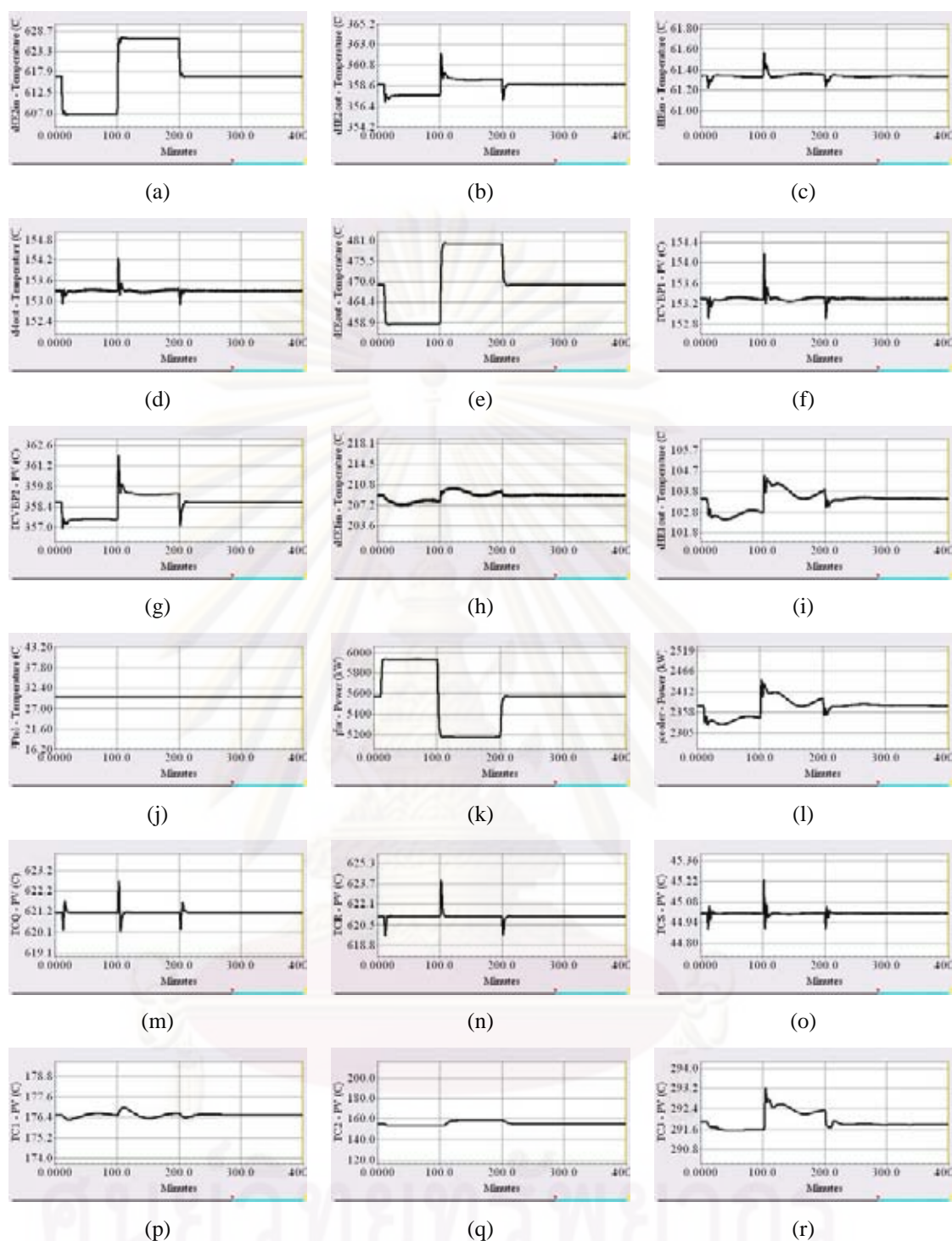

Figure 6.85 Dynamic responses of the HDA process HIP6.2 to a change in the heat load disturbance of hot stream (reactor product stream): CS₂, where: (a) FEHE2 hot inlet temperature, (b) FEHE2 hot outlet temperature, (c) FEHE1 cold inlet temperature, (d) FEHE2 cold inlet temperature, (e) FEHE2 cold outlet temperature, (f) FEHE1 bypass stream, (g) FEHE2 bypass stream, (h) FEHE1 hot inlet temperature, (i) FEHE1 hot outlet temperature, (j) fresh feed toluene temperature (k) furnace duty, (l) cooler duty, (m) quench temperature, (n) reactor inlet temperature, (o) separator temperature, (p) stabilizer column tray temperature, (q) product column tray temperature (r) recycle column tray temperature

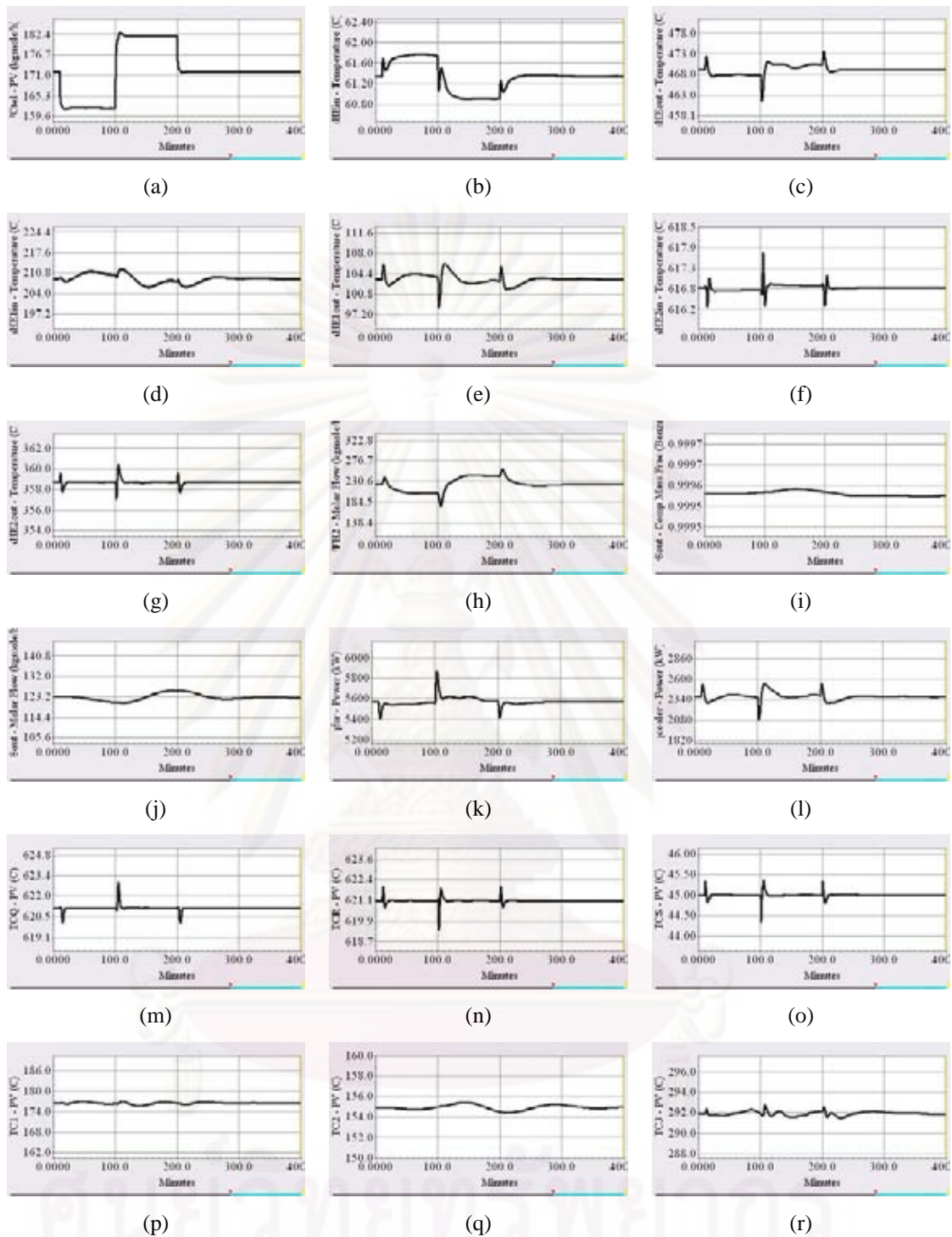

Figure 6.86 Dynamic responses of the HDA process HIP6.2 to a change in the total toluene feed flowrates: CS₂, where: (a) total toluene feed flowrates, (b) FEHE1 cold inlet temperature, (c) FEHE2 cold outlet temperature, (d) FEHE1 hot inlet temperature, (e) FEHE1 hot outlet temperature, (f) FEHE2 hot inlet temperature, (g) FEHE2 hot outlet temperature, (h) fresh feed hydrogen flowrates, (i) benzene purity, (j) benzene flowrate (k) furnace duty, (l) cooler duty, (m) quench temperature, (n) reactor inlet temperature, (o) separator temperature, (p) stabilizer column tray temperature, (q) product column tray temperature (r) recycle column tray temperature

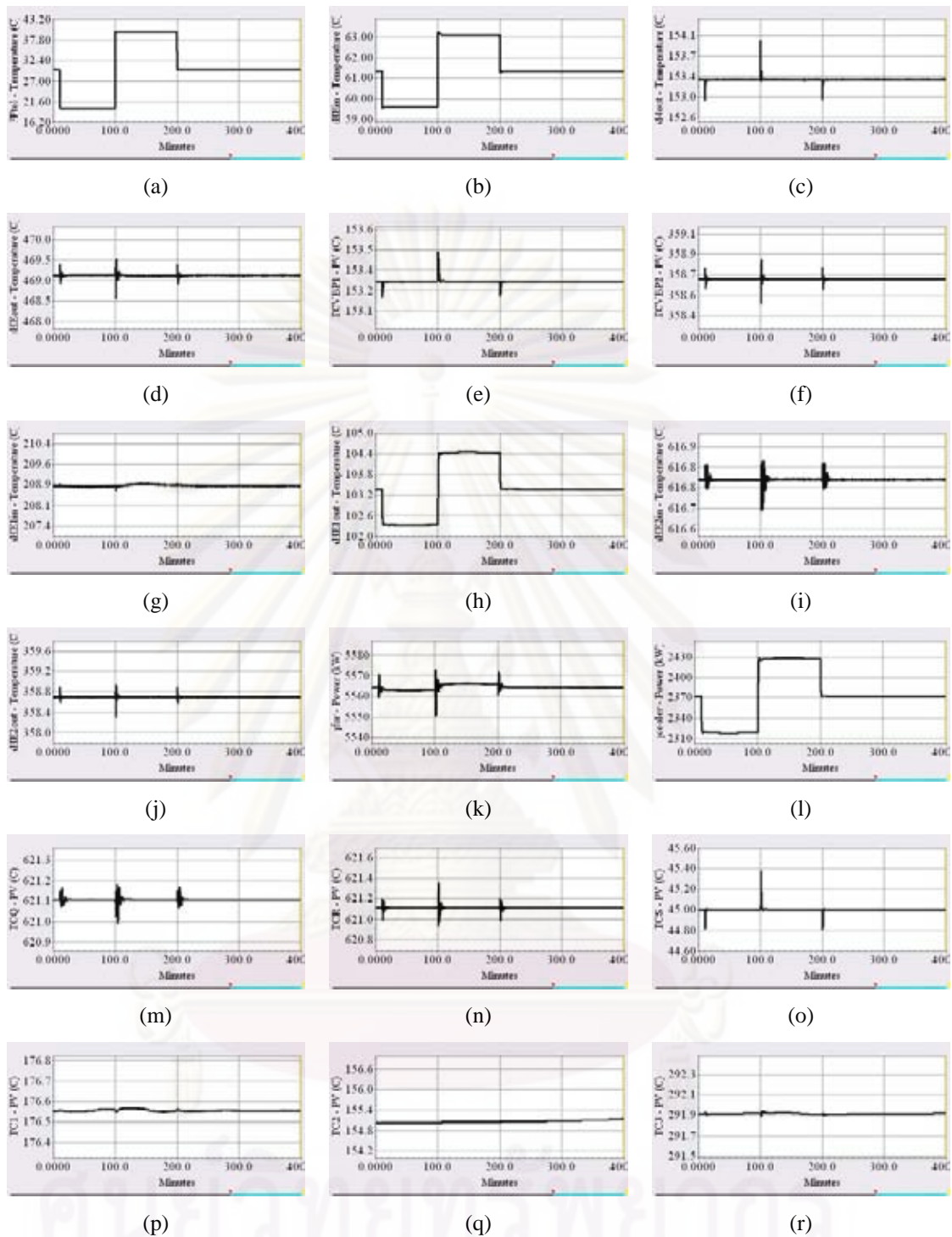

Figure 6.87 Dynamic responses of the HDA process HIP6.2 to a change in the heat load disturbance of cold stream (reactor feed stream): CS3, where: (a) fresh feed toluene temperature, (b) FEHE1 cold inlet temperature, (c) FEHE2 cold inlet temperature, (d) FEHE2 cold outlet temperature, (e) FEHE1 bypass stream, (f) FEHE2 bypass stream, (g) FEHE1 hot inlet temperature, (h) FEHE1 hot outlet temperature, (i) FEHE2 hot inlet temperature, (j) FEHE2 hot outlet temperature, (k) furnace duty, (l) cooler duty, (m) quench temperature, (n) reactor inlet temperature, (o) separator temperature, (p) stabilizer column tray temperature, (q) product column tray temperature (r) recycle column tray temperature

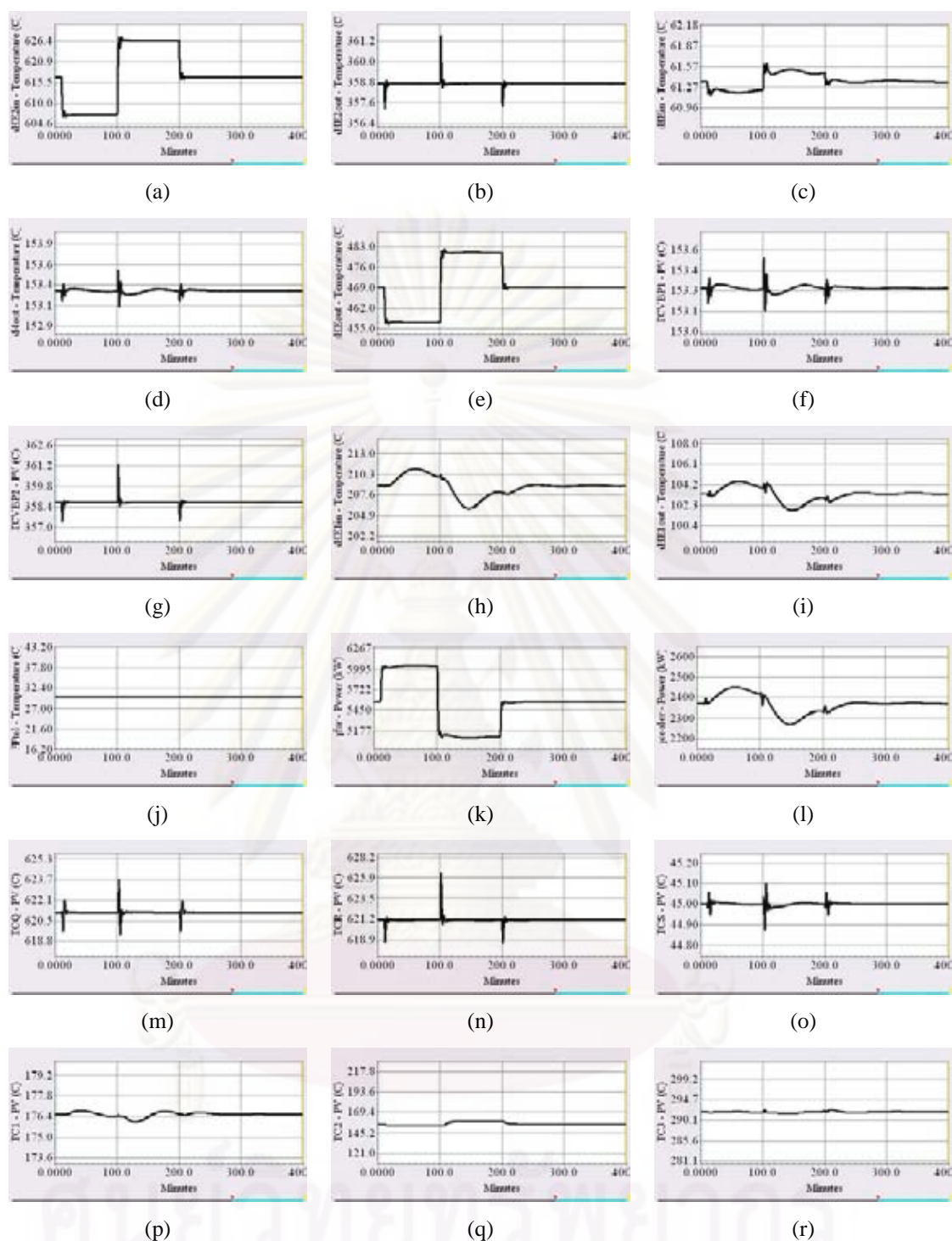

Figure 6.88 Dynamic responses of the HDA process HIP6.2 to a change in the heat load disturbance of hot stream (reactor product stream): CS3, where: (a) FEHE2 hot inlet temperature, (b) FEHE2 hot outlet temperature, (c) FEHE1 cold inlet temperature, (d) FEHE2 cold inlet temperature, (e) FEHE2 cold outlet temperature, (f) FEHE1 bypass stream, (g) FEHE2 bypass stream, (h) FEHE1 hot inlet temperature, (i) FEHE1 hot outlet temperature, (j) fresh feed toluene temperature (k) furnace duty, (l) cooler duty, (m) quench temperature, (n) reactor inlet temperature, (o) separator temperature, (p) stabilizer column tray temperature, (q) product column tray temperature (r) recycle column tray temperature

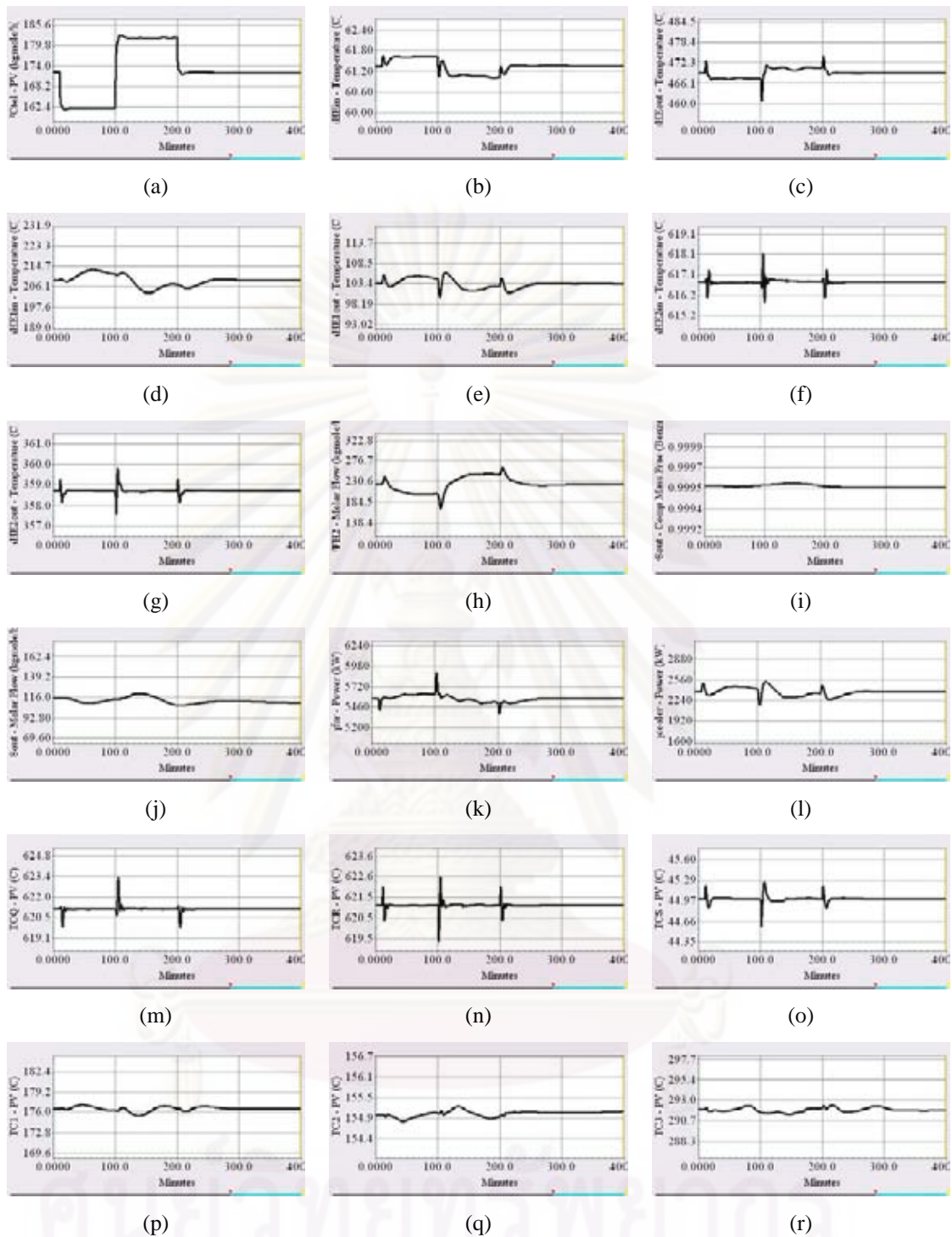

Figure 6.89 Dynamic responses of the HDA process HIP6.2 to a change in the total toluene feed flowrates: CS3, where: (a) total toluene feed flowrates, (b) FEHE1 cold inlet temperature, (c) FEHE2 cold outlet temperature, (d) FEHE1 hot inlet temperature, (e) FEHE1 hot outlet temperature, (f) FEHE2 hot inlet temperature, (g) FEHE2 hot outlet temperature, (h) fresh feed hydrogen flowrates, (i) benzene purity, (j) benzene flowrate (k) furnace duty, (l) cooler duty, (m) quench temperature, (n) reactor inlet temperature, (o) separator temperature, (p) stabilizer column tray temperature, (q) product column tray temperature (r) recycle column tray temperature

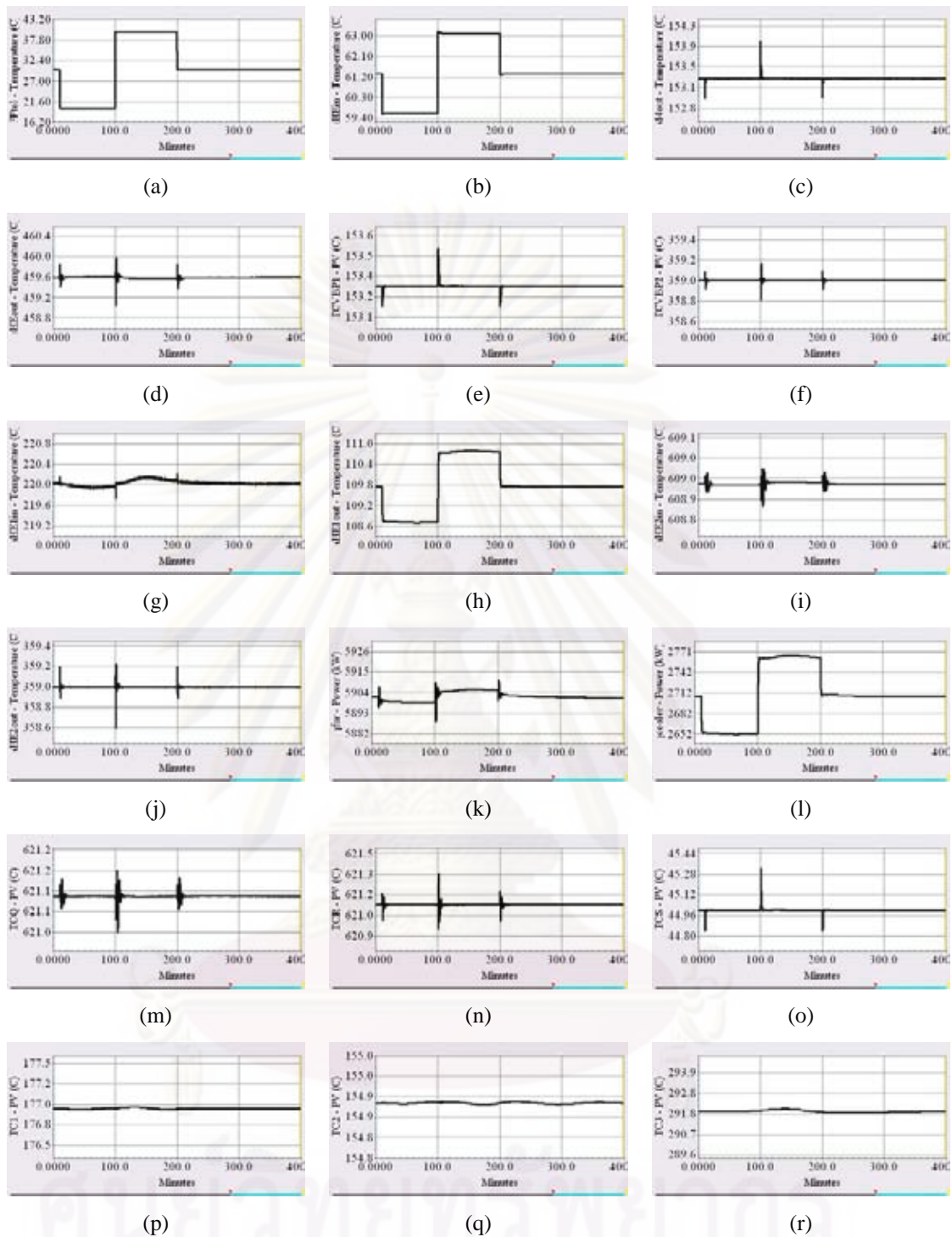

Figure 6.90 Dynamic responses of the HDA process HIP6.3 to a change in the heat load disturbance of cold stream (reactor feed stream): CS1, where: (a) fresh feed toluene temperature, (b) FEHE1 cold inlet temperature, (c) FEHE2 cold inlet temperature, (d) FEHE2 cold outlet temperature, (e) FEHE1 bypass stream, (f) FEHE2 bypass stream, (g) FEHE1 hot inlet temperature, (h) FEHE1 hot outlet temperature, (i) FEHE2 hot inlet temperature, (j) FEHE2 hot outlet temperature, (k) furnace duty, (l) cooler duty, (m) quench temperature, (n) reactor inlet temperature, (o) separator temperature, (p) stabilizer column tray temperature, (q) product column tray temperature (r) recycle column tray temperature

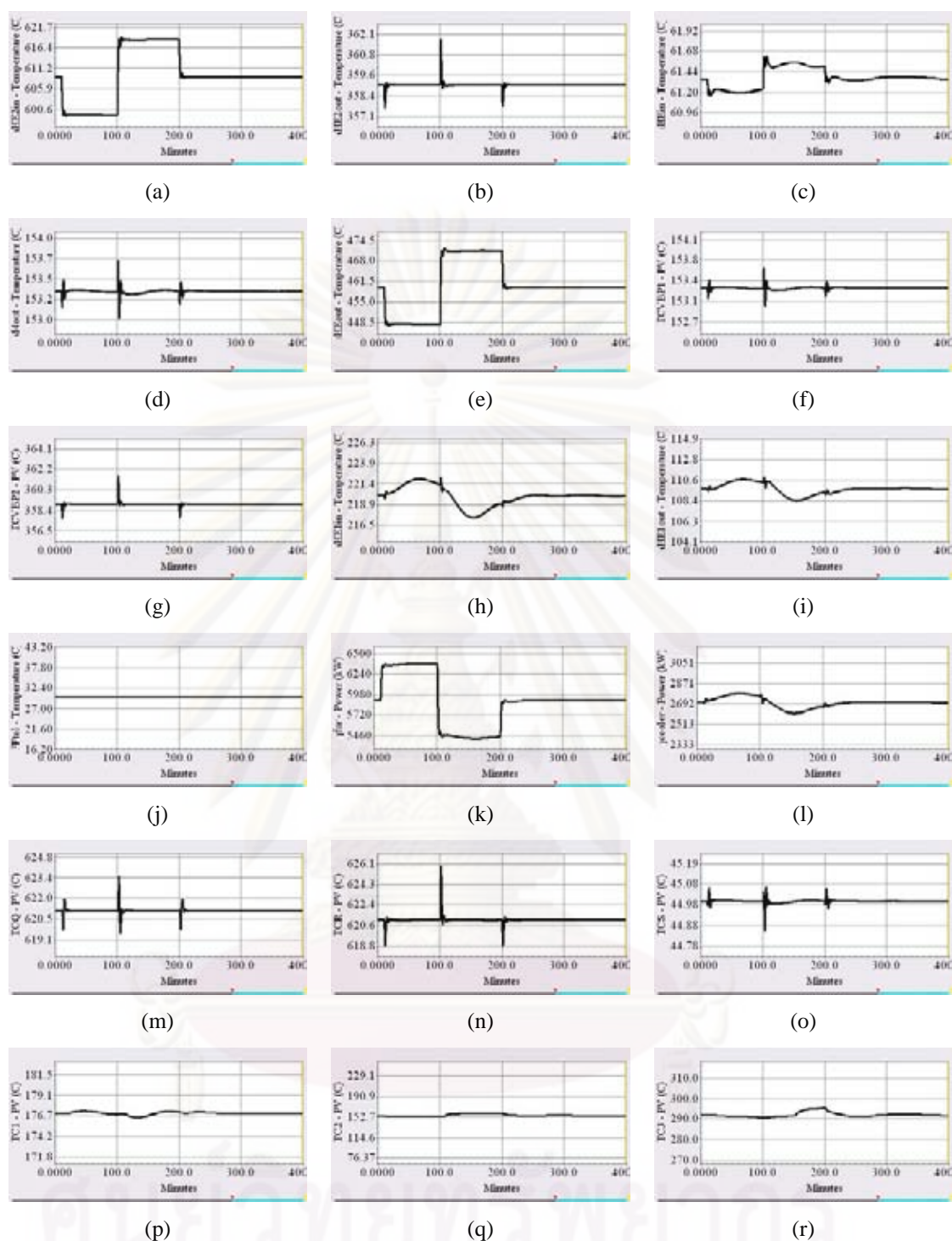

Figure 6.91 Dynamic responses of the HDA process HIP6.3 to a change in the heat load disturbance of hot stream (reactor product stream): CS1, where: (a) FEHE2 hot inlet temperature, (b) FEHE2 hot outlet temperature, (c) FEHE1 cold inlet temperature, (d) FEHE2 cold inlet temperature, (e) FEHE2 cold outlet temperature, (f) FEHE1 bypass stream, (g) FEHE2 bypass stream, (h) FEHE1 hot inlet temperature, (i) FEHE1 hot outlet temperature, (j) fresh feed toluene temperature (k) furnace duty, (l) cooler duty, (m) quench temperature, (n) reactor inlet temperature, (o) separator temperature, (p) stabilizer column tray temperature, (q) product column tray temperature (r) recycle column tray temperature

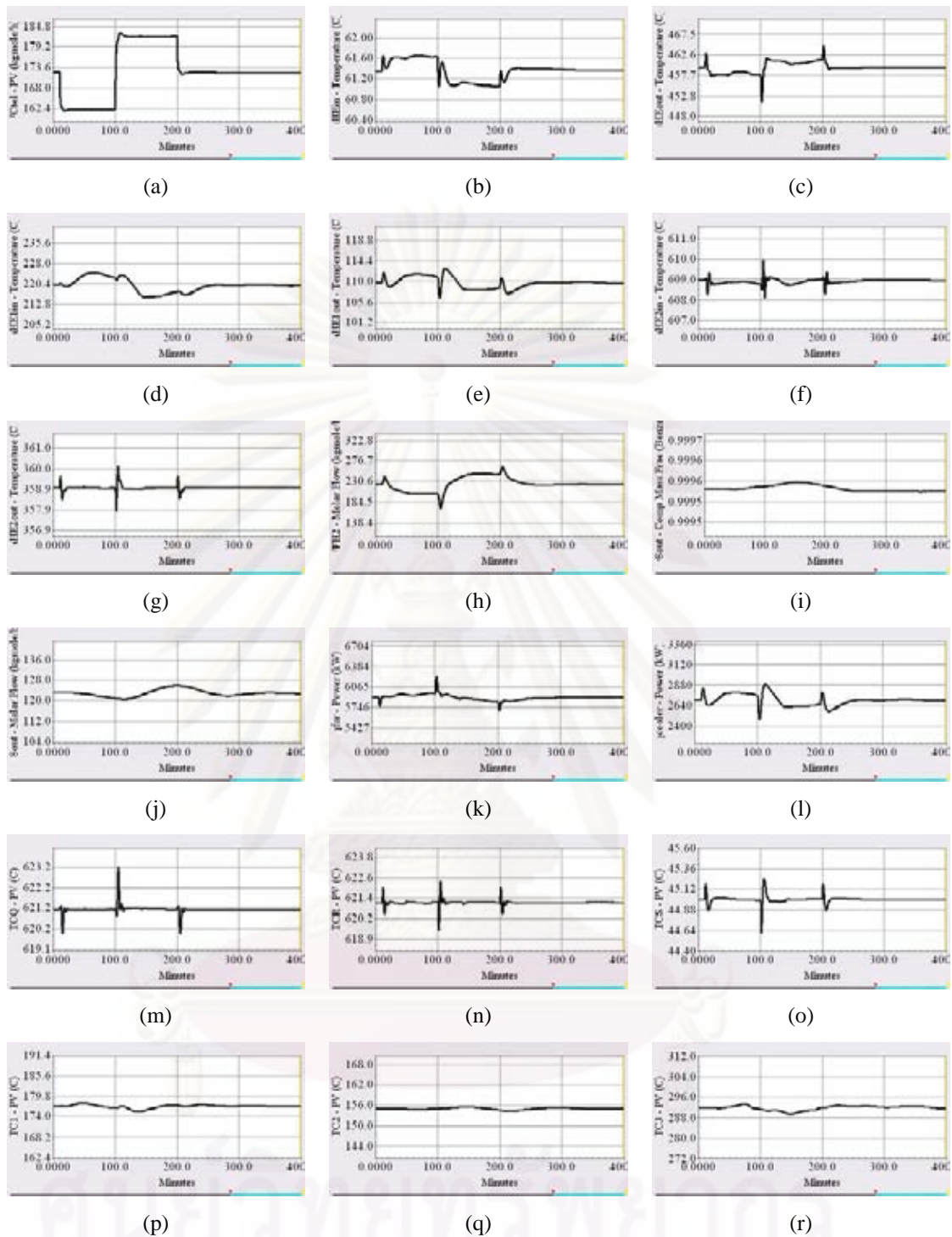

Figure 6.92 Dynamic responses of the HDA process HIP6.3 to a change in the total toluene feed flowrates: CS1, where: (a) total toluene feed flowrates, (b) FEHE1 cold inlet temperature, (c) FEHE2 cold outlet temperature, (d) FEHE1 hot inlet temperature, (e) FEHE1 hot outlet temperature, (f) FEHE2 hot inlet temperature, (g) FEHE2 hot outlet temperature, (h) fresh feed hydrogen flowrates, (i) benzene purity, (j) benzene flowrate (k) furnace duty, (l) cooler duty, (m) quench temperature, (n) reactor inlet temperature, (o) separator temperature, (p) stabilizer column tray temperature, (q) product column tray temperature (r) recycle column tray temperature

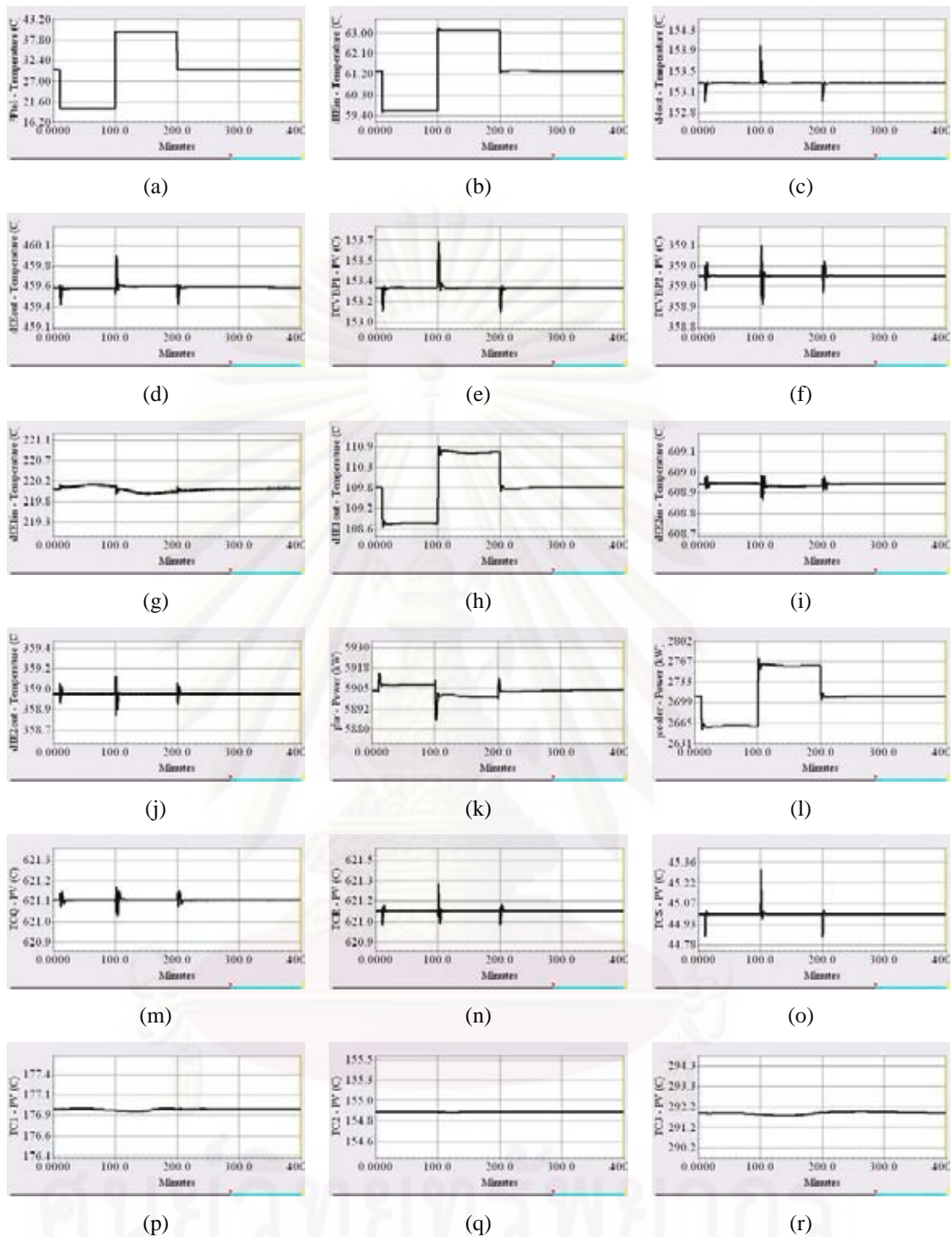

Figure 6.93 Dynamic responses of the HDA process HIP6.3 to a change in the heat load disturbance of cold stream (reactor feed stream): CS₂, where: (a) fresh feed toluene temperature, (b) FEHE1 cold inlet temperature, (c) FEHE2 cold inlet temperature, (d) FEHE2 cold outlet temperature, (e) FEHE1 bypass stream, (f) FEHE2 bypass stream, (g) FEHE1 hot inlet temperature, (h) FEHE1 hot outlet temperature, (i) FEHE2 hot inlet temperature, (j) FEHE2 hot outlet temperature, (k) furnace duty, (l) cooler duty, (m) quench temperature, (n) reactor inlet temperature, (o) separator temperature, (p) stabilizer column tray temperature, (q) product column tray temperature (r) recycle column tray temperature

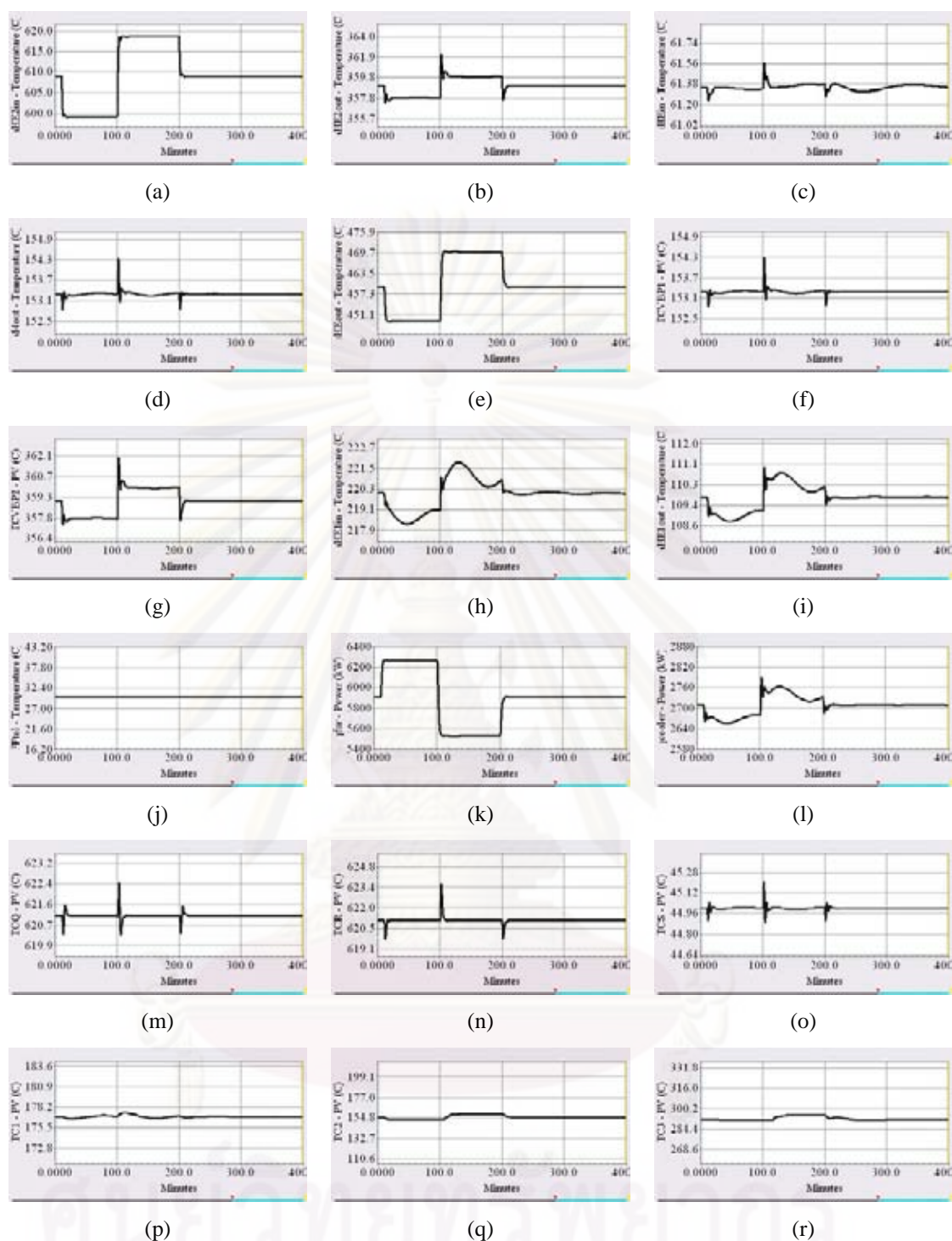

Figure 6.94 Dynamic responses of the HDA process HIP6.3 to a change in the heat load disturbance of hot stream (reactor product stream): CS2, where: (a) FEHE2 hot inlet temperature, (b) FEHE2 hot outlet temperature, (c) FEHE1 cold inlet temperature, (d) FEHE2 cold inlet temperature, (e) FEHE2 cold outlet temperature, (f) FEHE1 bypass stream, (g) FEHE2 bypass stream, (h) FEHE1 hot inlet temperature, (i) FEHE1 hot outlet temperature, (j) fresh feed toluene temperature (k) furnace duty, (l) cooler duty, (m) quench temperature, (n) reactor inlet temperature, (o) separator temperature, (p) stabilizer column tray temperature, (q) product column tray temperature (r) recycle column tray temperature

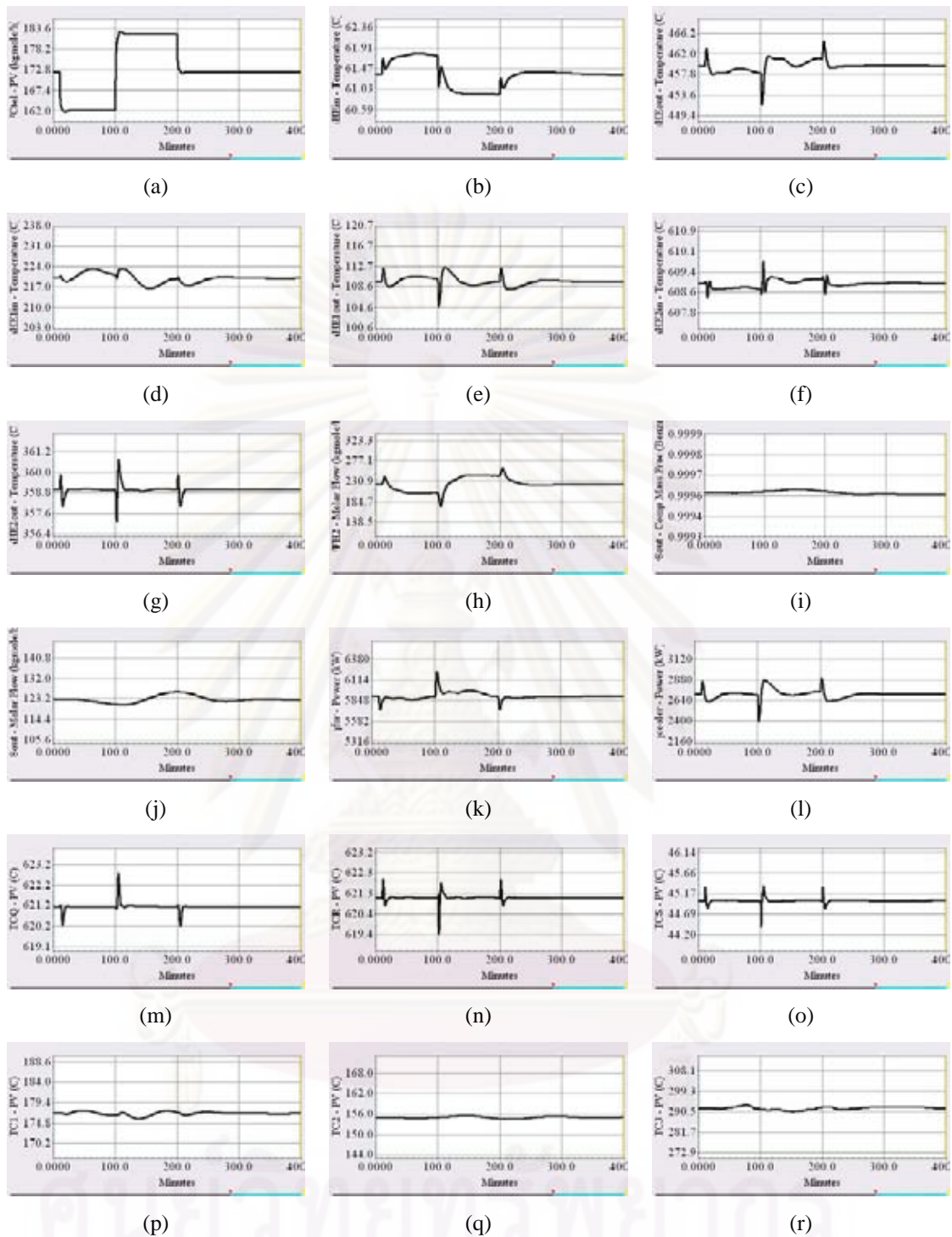

Figure 6.95 Dynamic responses of the HDA process HIP6.3 to a change in the total toluene feed flowrates: CS₂, where: (a) total toluene feed flowrates, (b) FEHE1 cold inlet temperature, (c) FEHE2 cold outlet temperature, (d) FEHE1 hot inlet temperature, (e) FEHE1 hot outlet temperature, (f) FEHE2 hot inlet temperature, (g) FEHE2 hot outlet temperature, (h) fresh feed hydrogen flowrates, (i) benzene purity, (j) benzene flowrate (k) furnace duty, (l) cooler duty, (m) quench temperature, (n) reactor inlet temperature, (o) separator temperature, (p) stabilizer column tray temperature, (q) product column tray temperature (r) recycle column tray temperature

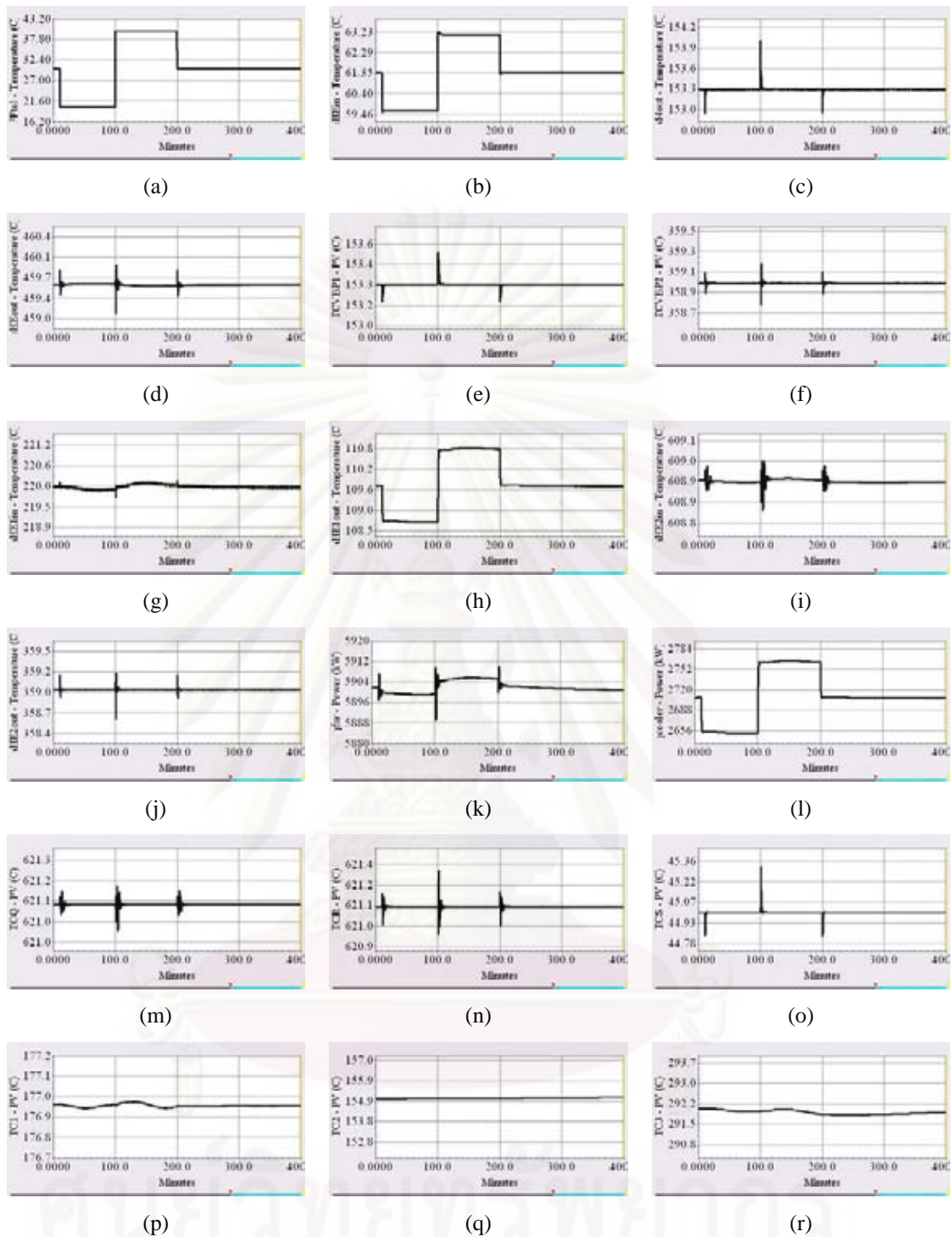

Figure 6.96 Dynamic responses of the HDA process HIP6.3 to a change in the heat load disturbance of cold stream (reactor feed stream): CS3, where: (a) fresh feed toluene temperature, (b) FEHE1 cold inlet temperature, (c) FEHE2 cold inlet temperature, (d) FEHE2 cold outlet temperature, (e) FEHE1 bypass stream, (f) FEHE2 bypass stream, (g) FEHE1 hot inlet temperature, (h) FEHE1 hot outlet temperature, (i) FEHE2 hot inlet temperature, (j) FEHE2 hot outlet temperature, (k) furnace duty, (l) cooler duty, (m) quench temperature, (n) reactor inlet temperature, (o) separator temperature, (p) stabilizer column tray temperature, (q) product column tray temperature (r) recycle column tray temperature

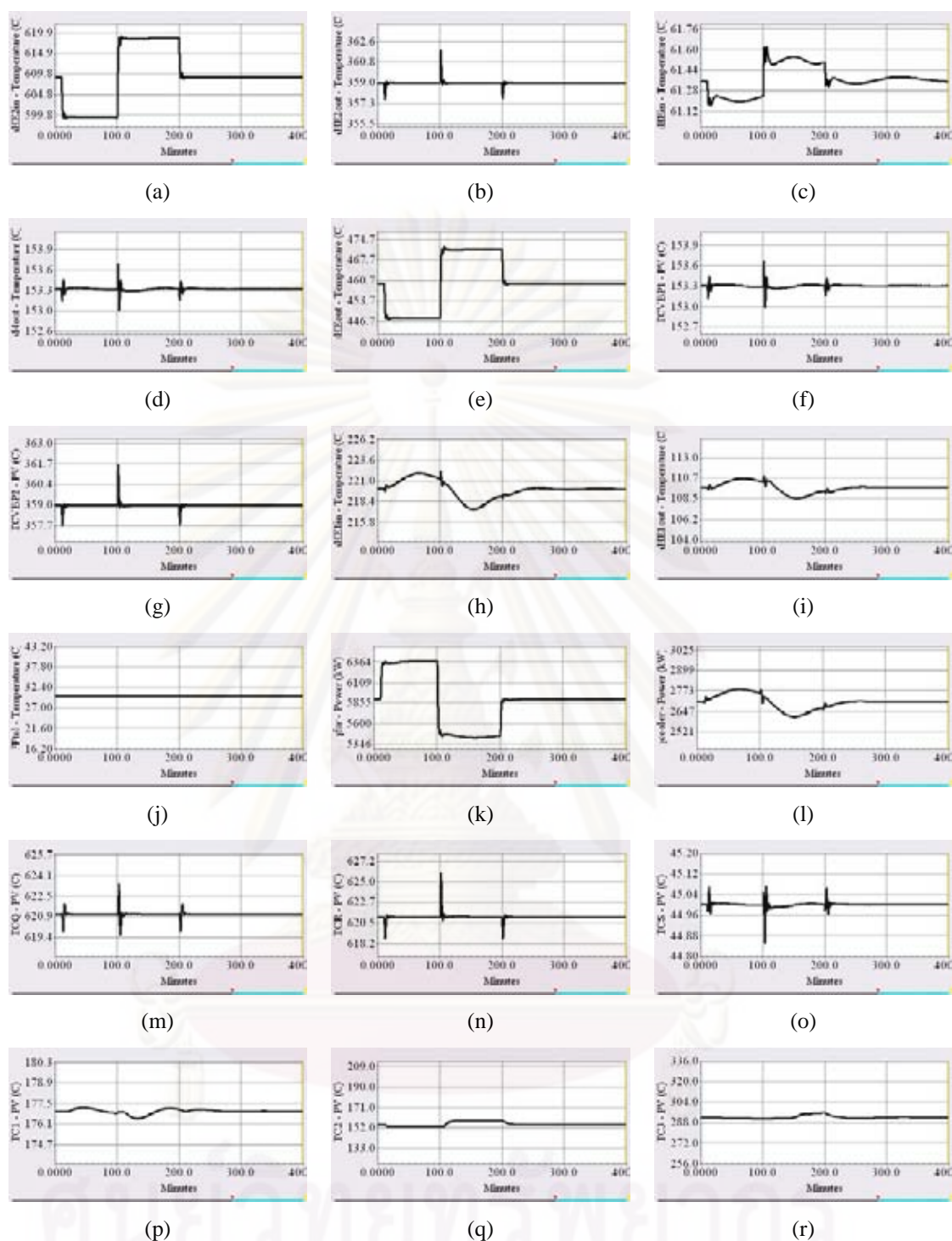

Figure 6.97 Dynamic responses of the HDA process HIP6.3 to a change in the heat load disturbance of hot stream (reactor product stream): CS3, where: (a) FEHE2 hot inlet temperature, (b) FEHE2 hot outlet temperature, (c) FEHE1 cold inlet temperature, (d) FEHE2 cold inlet temperature, (e) FEHE2 cold outlet temperature, (f) FEHE1 bypass stream, (g) FEHE2 bypass stream, (h) FEHE1 hot inlet temperature, (i) FEHE1 hot outlet temperature, (j) fresh feed toluene temperature (k) furnace duty, (l) cooler duty, (m) quench temperature, (n) reactor inlet temperature, (o) separator temperature, (p) stabilizer column tray temperature, (q) product column tray temperature (r) recycle column tray temperature

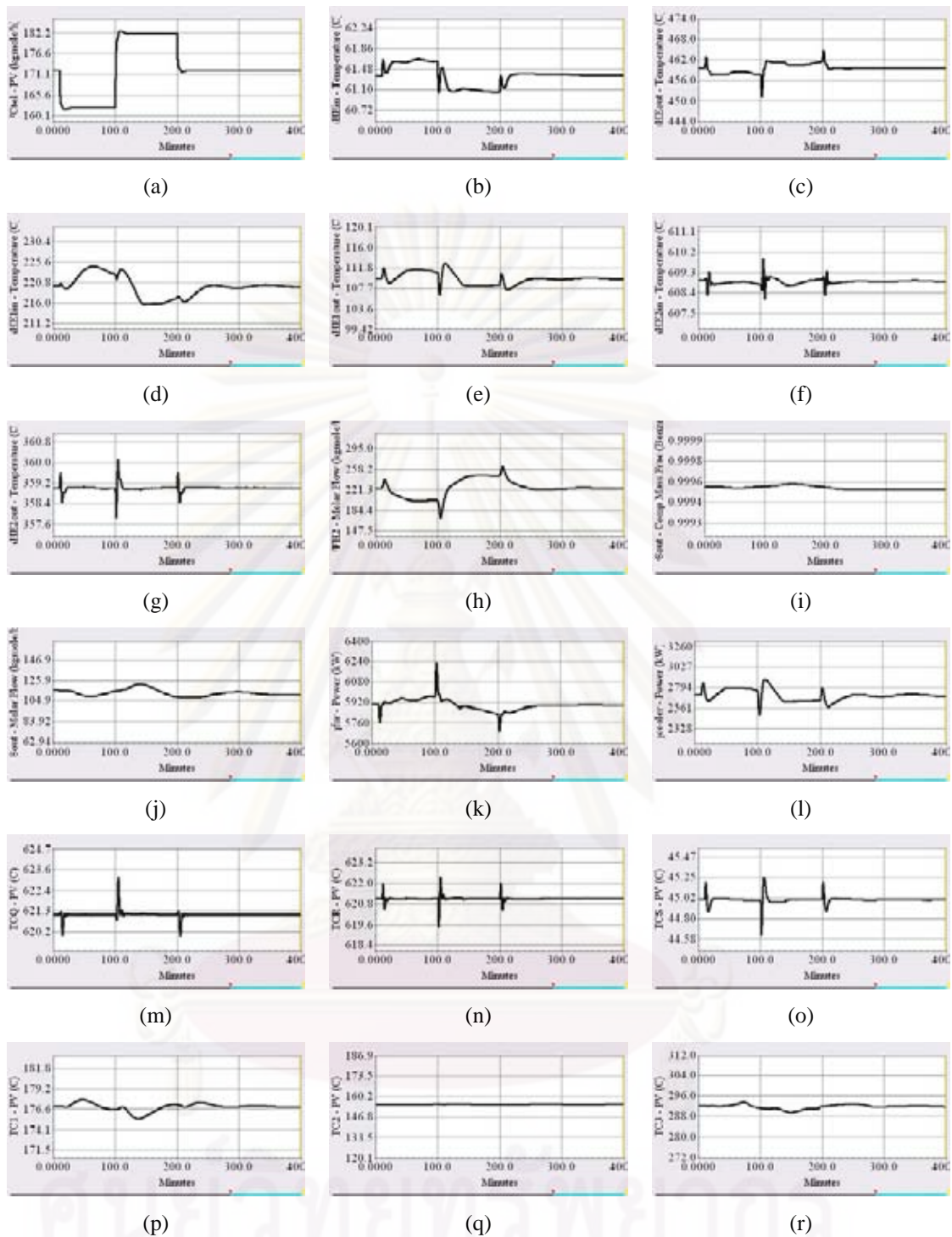

Figure 6.98 Dynamic responses of the HDA process HIP6.3 to a change in the total toluene feed flowrates: CS3, where: (a) total toluene feed flowrates, (b) FEHE1 cold inlet temperature, (c) FEHE2 cold outlet temperature, (d) FEHE1 hot inlet temperature, (e) FEHE1 hot outlet temperature, (f) FEHE2 hot inlet temperature, (g) FEHE2 hot outlet temperature, (h) fresh feed hydrogen flowrates, (i) benzene purity, (j) benzene flowrate (k) furnace duty, (l) cooler duty, (m) quench temperature, (n) reactor inlet temperature, (o) separator temperature, (p) stabilizer column tray temperature, (q) product column tray temperature (r) recycle column tray temperature

6.7 Evaluation of the Dynamic Performance

The dynamic performance index is focused on time related characteristics of the controller's response to setpoint changes or deterministic disturbances. There exist several candidate performance measures such as settling time and integral absolute error (IAE). Integral absolute error is well known and widely used. For the formulation of a dynamic performance as written below:

$$\text{IAE} = \int |\varepsilon(t)| dt$$

Note that $\varepsilon(t) = y_{sp}(t) - y(t)$ is the deviation (error) of the response from the desired setpoint.

In this work, IAE values are used to evaluate the dynamic performance of the designed control systems. Table 6.5 (a, b and c) are shown the IAE results of the complex heat-integrated typical HDA process. For the IAE results of the complex heat-integrated HDA process are shown in Table 6.6 (a, b and c).

The IAE results for the change in the disturbance loads of the cold stream, hot stream and total toluene feed flowrates of the complex heat-integrated typical HDA process and complex heat-integrated HDA process, the value of IAE in control structure (CS1) is smaller than another. The IAE of CS1 close to the IAE of CS3, and IAE of CS2 to high because CS2 exhibited very slow dynamics and is more sensitive to the disturbances. So, CS1 is the best control structure for handle disturbances due to it gives better control performances than CS3 and CS2 respectively.

Table 6.5a The IAE values of the complex heat-integrated typical HDA process alternative 5 (HIP5.0) and complex heat-integrated HDA process HIP5 (Both HIP5.1 and 5.2) to a change in the disturbance load of cold streams (reactor feed stream)

Controller	Integral Absolute Error (IAE)								
	CS1			CS2			CS3		
	HIP5.0	HIP5.1	HIP5.2	HIP5.0	HIP5.1	HIP5.2	HIP5.0	HIP5.1	HIP5.2
TC1	0.5128	0.3880	0.3308	0.5120	0.4793	0.4418	0.5126	0.2067	0.2401
TC2	0.0066	0.0247	0.0178	0.0506	0.0322	0.0328	0.0062	0.0066	0.1007
TC3	0.3779	0.3744	0.4734	0.4408	0.3593	0.3570	0.4528	0.4213	0.4206
TCVBP1	0.0113	0.0641	0.0575	0.0367	0.0413	0.0495	0.0109	0.1182	0.1111
TCVBP2	0.0069	0.0452	0.0318	0.0521	0.0461	0.0547	0.0058	0.1306	0.1147
TCQ	0.0173	0.0106	0.0227	0.0188	0.2099	0.2009	0.0170	0.0195	0.0033
TCR	0.0118	0.0628	0.0308	0.0158	0.0061	0.0235	0.0106	0.0897	0.0036
TCS	0.0041	0.0149	0.0242	0.0060	0.0105	0.0158	0.0062	0.0228	0.0230
Total	0.9487	0.9847	0.9890	1.1328	1.1847	1.1760	1.0221	1.0154	1.0171

Table 6.5b The IAE values of the complex heat-integrated typical HDA process alternative 5 (HIP5.0) and complex heat-integrated HDA process HIP5 (Both HIP5.1 and 5.2) to a change in the disturbance load of hot streams (reactor product stream)

Controller	Integral Absolute Error (IAE)								
	CS1			CS2			CS3		
	HIP5.0	HIP5.1	HIP5.2	HIP5.0	HIP5.1	HIP5.2	HIP5.0	HIP5.1	HIP5.2
TC1	0.5125	0.4533	0.4288	0.5119	0.4840	0.5157	0.5121	0.4342	0.4620
TC2	0.0346	0.0154	0.0146	0.0576	0.0175	0.0248	0.1090	0.0167	0.0171
TC3	0.5465	0.6117	0.6781	0.4697	0.6501	0.6748	0.4698	0.6738	0.6352
TCVBP1	0.0200	0.0138	0.0216	0.1486	0.0158	0.0115	0.0145	0.0141	0.0211
TCVBP2	0.0048	0.0505	0.0156	0.0418	0.0398	0.0223	0.0032	0.0271	0.0343
TCQ	0.0386	0.0063	0.0168	0.0368	0.0299	0.0268	0.0559	0.0108	0.0143
TCR	0.0457	0.0220	0.0154	0.0339	0.0398	0.0162	0.0468	0.0222	0.0147
TCS	0.0204	0.0212	0.0092	0.0199	0.0168	0.0042	0.0205	0.0026	0.0125
Total	1.2231	1.1942	1.2001	1.3202	1.2937	1.2963	1.2318	1.2015	1.2112

Table 6.5c The IAE values of the complex heat-integrated typical HDA process alternative 5 (HIP5.0) and complex heat-integrated HDA process HIP5 (Both HIP5.1 and 5.2) to a change in the disturbance load of total toluene feed flowrates

Controller	Integral Absolute Error (IAE)								
	CS1			CS2			CS3		
	HIP5.0	HIP5.1	HIP5.2	HIP5.0	HIP5.1	HIP5.2	HIP5.0	HIP5.1	HIP5.2
TC1	0.5128	0.3462	0.3687	0.5119	0.3016	0.3417	0.5128	0.3263	0.3312
TC2	0.0041	0.0154	0.0146	0.0132	0.0146	0.0163	0.0058	0.0167	0.0165
TC3	0.7995	0.7271	0.5923	0.8246	0.8842	0.8509	0.7975	0.7991	0.7639
TCVBP1	0.0038	0.0267	0.0345	0.0372	0.0332	0.0316	0.0090	0.0195	0.0218
TCVBP2	0.0036	0.0276	0.1320	0.0133	0.0158	0.0236	0.0025	0.0508	0.0103
TCQ	0.0052	0.0230	0.0218	0.0087	0.0487	0.0243	0.0066	0.0103	0.0231
TCR	0.0220	0.0433	0.0271	0.0021	0.0599	0.0133	0.0024	0.0267	0.0246
TCS	0.0040	0.0410	0.0211	0.0034	0.0159	0.0130	0.0023	0.0101	0.0230
Total	1.3550	1.2503	1.2121	1.4144	1.3739	1.3147	1.3389	1.2595	1.2144

Table 6.6a The IAE values of the complex heat-integrated typical HDA process alternative 6 (HIP6.0) and complex heat-integrated HDA process HIP6 (HIP6.1, 6.2 and 6.3) to a change in the disturbance load of cold streams (reactor feed stream)

Controller	Integral Absolute Error (IAE)											
	CS1				CS2				CS3			
	HIP6.0	HIP6.1	HIP6.2	HIP6.3	HIP6.0	HIP6.1	HIP6.2	HIP6.3	HIP6.0	HIP6.1	HIP6.2	HIP6.3
TC1	0.4742	0.1279	0.1670	0.1339	0.4738	0.0771	0.0907	0.2200	0.4742	0.2785	0.3674	0.2115
TC2	0.0059	0.2021	0.0388	0.0388	0.0156	0.0288	0.0383	0.0375	0.0129	0.0431	0.0364	0.0458
TC3	0.5396	0.5067	0.5330	0.5760	0.6013	0.6863	0.5530	0.4861	0.5552	0.5785	0.3723	0.4172
TCVBP1	0.0096	0.0320	0.1066	0.0123	0.0296	0.1261	0.1534	0.1846	0.0128	0.0365	0.0706	0.1133
TCVBP2	0.0020	0.0238	0.1026	0.0728	0.0043	0.0235	0.0294	0.0155	0.0042	0.0278	0.0818	0.0331
TCQ	0.0067	0.1097	0.0120	0.1712	0.0098	0.1212	0.0688	0.1246	0.0078	0.0536	0.0300	0.1794
TCR	0.0044	0.0098	0.0561	0.0109	0.0053	0.0144	0.1155	0.0123	0.0043	0.0153	0.0524	0.0264
TCS	0.0013	0.0194	0.0209	0.0198	0.0018	0.0406	0.0701	0.0310	0.0015	0.0194	0.0315	0.0288
Total	1.0437	1.0314	1.0370	1.0357	1.1415	1.1180	1.1192	1.1116	1.0729	1.0527	1.0424	1.0555

Table 6.6b The IAE values of the complex heat-integrated typical HDA process alternative 6 (HIP6.0) and complex heat-integrated HDA process HIP6 (HIP6.1, 6.2 and 6.3) to a change in the disturbance load of hot streams (reactor product stream)

Controller	Integral Absolute Error (IAE)											
	CS1				CS2				CS3			
	HIP6.0	HIP6.1	HIP6.2	HIP6.3	HIP6.0	HIP6.1	HIP6.2	HIP6.3	HIP6.0	HIP6.1	HIP6.2	HIP6.3
TC1	0.4706	0.4247	0.4004	0.4006	0.4738	0.3533	0.4160	0.3073	0.4700	0.4232	0.4202	0.4669
TC2	0.0256	0.0404	0.0388	0.0385	0.1096	0.0577	0.0383	0.0388	0.0351	0.0431	0.0230	0.0285
TC3	0.7108	0.6650	0.6605	0.6255	0.6558	0.6033	0.6739	0.5858	0.6684	0.6230	0.6473	0.6519
TCVBP1	0.0130	0.0105	0.0137	0.0203	0.0307	0.1437	0.0345	0.1296	0.0236	0.0342	0.0225	0.0069
TCVBP2	0.0162	0.0113	0.0453	0.0035	0.0414	0.0111	0.0323	0.0048	0.0278	0.0177	0.0454	0.0222
TCQ	0.0059	0.0203	0.0077	0.0513	0.0057	0.1086	0.0363	0.1723	0.0035	0.0182	0.0199	0.0218
TCR	0.0075	0.0338	0.0409	0.0296	0.0272	0.0045	0.0415	0.0573	0.0540	0.0511	0.0301	0.0156
TCS	0.0014	0.0050	0.0020	0.0330	0.0047	0.0107	0.0147	0.0139	0.0049	0.0066	0.0046	0.0154
Total	1.2510	1.2110	1.2093	1.2023	1.3489	1.2929	1.2875	1.3098	1.2873	1.2171	1.2130	1.2292

Table 6.6c The IAE values of the complex heat-integrated typical HDA process alternative 6 (HIP6.0) and complex heat-integrated HDA process HIP6 (HIP6.1, 6.2 and 6.3) to a change in the disturbance load of total toluene feed flowrates

Controller	Integral Absolute Error (IAE)											
	CS1				CS2				CS3			
	HIP6.0	HIP6.1	HIP6.2	HIP6.3	HIP6.0	HIP6.1	HIP6.2	HIP6.3	HIP6.0	HIP6.1	HIP6.2	HIP6.3
TC1	0.4740	0.3765	0.3723	0.3944	0.4738	0.4761	0.4777	0.4668	0.4740	0.4329	0.3826	0.3768
TC2	0.0083	0.0404	0.0441	0.0388	0.0083	0.0577	0.0543	0.1137	0.0027	0.0431	0.0423	0.0352
TC3	0.8008	0.7125	0.7008	0.6969	0.8193	0.7332	0.7408	0.7230	0.8021	0.6972	0.7052	0.6993
TCVBP1	0.0238	0.0378	0.0204	0.0232	0.0521	0.0212	0.0145	0.0084	0.0261	0.0354	0.0206	0.0207
TCVBP2	0.0016	0.0413	0.0309	0.0044	0.0123	0.0146	0.0139	0.0041	0.0279	0.0145	0.0339	0.0164
TCQ	0.0123	0.0233	0.0590	0.0388	0.0237	0.0177	0.0208	0.0309	0.0017	0.0152	0.0546	0.0463
TCR	0.0034	0.0031	0.0065	0.0351	0.0092	0.0253	0.0298	0.0068	0.0129	0.0122	0.0113	0.0588
TCS	0.0238	0.0014	0.0033	0.0065	0.0085	0.0156	0.0151	0.0117	0.0132	0.0069	0.0016	0.0043
Total	1.3480	1.2363	1.2373	1.2381	1.4072	1.3614	1.3669	1.3654	1.3606	1.2574	1.2521	1.2578

CHAPTER VII

CONCLUSIONS AND RECOMMENDATIONS

7.1 Conclusions

The new sequence of separation section in hydrodealkylation (HDA) process has been studied by Pronpitakthum (2008). He studied the HDA process alternative 1 to 4 which are non-highly heat integrated process. He found that the HDA process alternative 1 to 4 which are consists of the new sequence of separation section can save the energy usage 5.7-20.4 percent from the alternative 1. In this thesis, the new sequence of separation section for HDA process alternative 5 and 6 which are complex heat-integrated process are considered. They can save the energy usage approximate 21 percent from the alternative 1. So, the energy usage of hot and cold utilities in the complex heat-integrated HDA process alternative 5 and 6 are less than the HDA process alternative 1 to 4 which was studied by Pronpitakthum (2008).

In addition we design the three plantwide control structures (CS1, CS2 and CS3) for the complex heat-integrated HDA process alternative 5 and 6. The CS1, temperature at feed effluent heat exchanger (FEHE) is controlled by the bypass of cold stream. For the CS2, temperature at FEHE is controlled by the bypass of hot stream and the CS3, the temperature in product distillation column is controlled two points as the bottom stage and tray 2 of product column. The plantwide control structures are designed by using the disturbance load propagation method, the resilient heat exchanger network (HEN) synthesis method by Wongsri (1990) and the heat pathway heuristics (HPH) by Wongsri and Hermawan (2005). The thermal and material disturbances are used to test the three plantwide control structures. The performances of the plantwide control structures are evaluated by the integral absolute error (IAE). In our work, the IAE of CS1 close to the IAE of CS3, and the IAE of CS2 is highest because CS2 is more sensitive to the disturbances. Hence, the control performance of CS1 is better than CS2 and CS3, respectively.

7.2 Recommendations

Study and design the control structure of complex heat-exchanger networks (HENs) and heat-integrated plants (HIPs) of the other process in plantwide control point of view.



ศูนย์วิจัยทรัพยากร
จุฬาลงกรณ์มหาวิทยาลัย

REFERENCES

- B.G. Rong, A Kraslawski, L. Nystrom., Design and synthesis of multicomponent thermally coupled distillation flowsheets, Comp and Chem. Eng. 25 (2001): 807-820.
- Calandranis, J. and Stephanopoulos, G.A Structural Approach to the Design of Control Systems in Heat Exchanger Networks. Comput. Chem. Eng. 12 (1988): 651-669.
- Douglas, J.M. Conceptual Design of Chemical Process. New York: McGraw-Hill, 1988.
- Guthrie, K.M. Data and Techniques for preliminary Capital Cost Estimating. Chem.Eng. (1969): 114-142.
- Handogo, R., and Luyben W.L. Design and Control of a Heat-Integrated Reactor/Column Process. Ind. Eng. Chem. Res. 26 (1987): 531-538.
- Handogo, R., and Luyben, W. L. (1987). Design and Control of a Heat-Integrated Reactor/Column Process. Ind. Eng. Chem. Res. 26, 531-538.
- Kietawarin, S. Control Structure Design Applied to Hydrodealkylation Process Plantwide Control Problem. M. Eng., Chemical Engineering, Chulalongkorn University, 2002.
- Kunlawaniteewat, J. Heat Exchanger Network Control Structure Design. M. Eng., Chemical Engineering, Chulalongkorn University, 2001.
- Leonardo, L., Giovanini and Jacinto L. Marchetti. Low-level flexible-structure control applied to heat exchanger networks. Comput. Chem. Eng. 27 (2003): 1129-1142.
- Lin, S. W., Yu, C. C., Design and control for recycle plants with heat-integrated separators, Chem. Eng. Sci. 59, 53 (2004).
- Luyben, M.L., Bjorn, D., Tyreus, and Luyben, W.L. Plantwide Process Control. New York: McGraw-Hill, 1999.
- Luyben, M.L., Tyreus, B.D. and Luyben, W.L. Design Plantwide Control Procedure. AIChE Journal 43 (1997): 3161-3174.
- Luyben, W.L. Control of Outlet Temperature in Adiabatic Tubular Reactor. Ind. Eng. Chem. Res. 39 (2000): 1271-1278.

- Luyben, W.L. Design and Control of Gas-Phase Reactor/Recycle Process with Reversible Exothermic Reactions. Ind. Eng. Chem. Res. 39 (2000)
- Luyben, W.L. Plantwide Dynamic Simulations in Chemical Processing and Control. New York: Marcel Dekker, 2002.
- N.V.S.N.M. Konda and G.P.Rangaiah, Performance Assessment of Plantwide Control Systems of Industrial Processes. Ind.Eng.Chem. Res., 46 (2007): 1220-1231.
- Pilavachi, P. A., Schenk, M., Bek-Pederson, E., Gani, R., Design and analysis of separation by distillation: role of property models, Trans. IChemE 78, 217 (2000).
- Ploypaisangsang, A. Resilient Heat Exchanger Network Design of Hydrodealkylation Process. M. Eng., Chemical Engineering, Chulalongkorn University, 2003.
- Qiu, Q.F., Rangaiah, G.P. and Krishnaswamy, P.R. Application of a plant-wide control design to the HDA process. Computers and Chemical Engineering journal 27 (2003): 73-94.
- Saboo, A. K. and Morari, M. (1984), Design of Resilient Processing Plants-IV: Some New Result on Heat Exchanger Network Synthesis, Chem. Eng. Sci., 39(3)
- Seborg, D.E., Edgar, T.F. and Mellichamp, D.A. Process Dynamic and Control. New York: John Wiley & Sons, 1989.
- Skogestad, S. Control structure design for complete chemical plants. Computers and Chemical Engineering journal 28 (2004): 219-234.
- Terrill, D.L. and Douglas, J.M. A T-H Method for Heat Exchanger Network Synthesis. Ind. Eng. Chem. Res. 26 (1987): 175-179.
- Thaicharoen, C. Design of Control Structure for Energy-Integrated Hydrodealkylation Process. M. Eng., Chemical Engineering, Chulalongkorn University, 2004.
- Ulrich, G. D. A Guide to Chemical Engineering Process Design and Economics. New York: Wiley, (1984).
- Wang, P., McAvoy, T. J., Synthesis of plantwide control systems using dynamic model and optimization, Ind. Eng. Chem. Res., 40 (2001): 5732.
- Wongsri, M. and Hermawan, Y. D. Heat Pathway Management for Complex Energy Integrated Plant: Dynamic Simulation of HDA Plant. J. Chin. Inst. Chem. Engrs. 36 (2005): 1-27.
- Wongsri, M. Resilient of Heat Exchanger Network Design, D. Sc. Dissertation Sever Institute of Technology Washington University, 1990.



APPENDICES

ศูนย์วิทยทรัพยากร
จุฬาลงกรณ์มหาวิทยาลัย

APPENDIX A

PROCESS STREAM DATA OF COMPLEX HEAT-INTEGRATED HDA PLANT

Table A.1 Process stream data for complex heat-integrated HDA plant HIP5

Stream name	FFH2	FFtol	v1out	v2out	Rtol	toltot
Temperature [C]	30.0000	30.0000	29.9944	30.1915	140.2060	58.3100
Pressure [psia]	625.0000	625.0000	575.0000	575.0000	575.0000	575.0000
Molar flow [kgmole/hr]	222.4349	131.9332	222.4349	131.9332	39.6619	171.5951
H ₂ mole fraction	0.9700	0.0000	0.9700	0.0000	0.0000	0.0000
CH ₄	0.0300	0.0000	0.0300	0.0000	0.0000	0.0000
C ₆ H ₆	0.0000	0.0000	0.0000	0.0000	0.0017	0.0004
C ₇ H ₈	0.0000	1.0000	0.0000	1.0000	0.9982	0.9996
C ₁₂ H ₁₀	0.0000	0.0000	0.0000	0.0000	0.0000	0.0000

Stream name	Rgas	cHE1in	cHE2in	hHE1in	hHE1out	cHE2out
Temperature [C]	65.4530	60.8841	201.3417	214.0038	78.1300	506.4415
Pressure [psia]	575.0000	575.0000	545.0000	478.0000	476.0000	515.0000
Molar flow [kgmole/hr]	1610.6998	2004.7299	2004.7299	2054.4499	2054.4499	2004.7299
H ₂ mole fraction	0.3983	0.4276	0.4276	0.3548	0.3548	0.4276
CH ₄	0.5905	0.4778	0.4778	0.5312	0.5312	0.4778
C ₆ H ₆	0.0100	0.0081	0.0081	0.0862	0.0862	0.0081
C ₇ H ₈	0.0012	0.0865	0.0865	0.0260	0.0260	0.0865
C ₁₂ H ₁₀	0.0000	0.0000	0.0000	0.0018	0.0018	0.0000

Stream name	hHE2in	hCR3in	Rin	Rout	quen	tot
Temperature [C]	620.9969	363.2400	621.1111	665.7695	45.3299	620.9966
Pressure [psia]	486.0000	484.0000	503.0000	486.0000	486.0000	486.0000
Molar flow [kgmole/hr]	2054.4499	2054.4499	2004.7299	2004.7299	49.7200	2054.4499
H ₂ mole fraction	0.3548	0.3548	0.4276	0.3635	0.0046	0.3548
CH ₄	0.5312	0.5312	0.4778	0.5433	0.0449	0.5312
C ₆ H ₆	0.0862	0.0862	0.0081	0.0708	0.7067	0.0862
C ₇ H ₈	0.0260	0.0260	0.0865	0.0210	0.2277	0.0260
C ₁₂ H ₁₀	0.0018	0.0018	0.0000	0.0014	0.0161	0.0018

Table A.1 Continued

Stream name	hCR1in	hCR1out	boil1	d3	p4out	v3out
Temperature [C]	353.8793	214.0038	239.4000	137.5752	140.1136	140.2035
Pressure [psia]	481.0000	478.0000	102.2500	29.9938	625.0000	575.0000
Molar flow [kgmole/hr]	2054.4499	2054.4499	445.1500	39.7615	39.7615	39.7615
H ₂ mole fraction	0.3548	0.3548	0.0000	0.0000	0.0000	0.0000
CH ₄	0.5312	0.5312	0.0000	0.0000	0.0000	0.0000
C ₆ H ₆	0.0862	0.0862	0.0019	0.0018	0.0018	0.0018
C ₇ H ₈	0.0260	0.0260	0.9317	0.9982	0.9982	0.9982
C ₁₂ H ₁₀	0.0018	0.0018	0.0664	0.0000	0.0000	0.0000

Stream name	c3out	p3out	b3	v14in	v13out	cCR3in
Temperature [C]	290.5141	290.5805	290.5805	290.5805	258.3424	290.5879
Pressure [psia]	30.5739	55.4300	55.4300	55.4300	15.7400	44.8200
Molar flow [kgmole/hr]	27.6338	27.6338	2.8368	24.7970	2.8368	24.7970
H ₂ mole fraction	0.0000	0.0000	0.0000	0.0000	0.0000	0.0000
CH ₄	0.0000	0.0000	0.0000	0.0000	0.0000	0.0000
C ₆ H ₆	0.0000	0.0000	0.0000	0.0000	0.0000	0.0000
C ₇ H ₈	0.0026	0.0026	0.0026	0.0026	0.0026	0.0026
C ₁₂ H ₁₀	0.9974	0.9974	0.9974	0.9974	0.9974	0.9974

Stream name	cCR3out	hCR3in	boil3	v5out
Temperature [C]	291.9000	363.2400	291.9000	45.6936
Pressure [psia]	30.4500	484.0000	30.4500	100.6000
Molar flow [kgmole/hr]	24.7970	2054.4499	24.7970	174.9897
H ₂ mole fraction	0.0000	0.3548	0.0000	0.0046
CH ₄	0.0000	0.5312	0.0000	0.0449
C ₆ H ₆	0.0000	0.0862	0.0000	0.7066
C ₇ H ₈	0.0026	0.0260	0.0025	0.2278
C ₁₂ H ₁₀	0.9974	0.0018	0.9975	0.0160

ศูนย์วิทยทรัพยากร
จุฬาลงกรณ์มหาวิทยาลัย

Table A.2 Process stream data for complex heat-integrated HDA plant HIP6

Stream name	FFH2	FFtol	v1out	v2out	Rtol	toltot
Temperature [C]	30.0000	30.0000	29.9944	30.1915	140.2155	58.5893
Pressure [psia]	625.0000	625.0000	575.0000	575.0000	575.0000	575.0000
Molar flow [kgmole/hr]	222.4349	131.9332	222.4349	131.9332	40.1882	172.1214
H ₂ mole fraction	0.9700	0.0000	0.9700	0.0000	0.0000	0.0000
CH ₄	0.0300	0.0000	0.0300	0.0000	0.0000	0.0000
C ₆ H ₆	0.0000	0.0000	0.0000	0.0000	0.0015	0.0004
C ₇ H ₈	0.0000	1.0000	0.0000	1.0000	0.9984	0.9996
C ₁₂ H ₁₀	0.0000	0.0000	0.0000	0.0000	0.0000	0.0000

Stream name	Rgas	cHE1in	cHE2in	hHE1in	hHE1out	cHE2out
Temperature [C]	66.1202	61.3225	197.6417	208.6253	77.0300	503.5268
Pressure [psia]	575.0000	575.0000	545.0000	475.0000	473.0000	515.0000
Molar flow [kgmole/hr]	1610.7152	2005.2716	2005.2716	2054.9816	2054.9816	2005.2716
H ₂ mole fraction	0.3956	0.4254	0.4254	0.3525	0.3525	0.4254
CH ₄	0.5931	0.4797	0.4797	0.5332	0.5332	0.4797
C ₆ H ₆	0.0101	0.0081	0.0081	0.0863	0.0863	0.0081
C ₇ H ₈	0.0012	0.0868	0.0868	0.0262	0.0262	0.0868
C ₁₂ H ₁₀	0.0000	0.0000	0.0000	0.0018	0.0018	0.0000

Stream name	hHE2in	hCR3in	Rin	Rout	quench	tot
Temperature [C]	613.2205	363.2400	621.1111	665.7188	45.3400	621.0367
Pressure [psia]	483.0000	484.0000	503.0000	486.0000	486.0000	486.0000
Molar flow [kgmole/hr]	2054.9816	2054.4499	2005.2716	2005.2716	49.7100	2054.9816
H ₂ mole fraction	0.3525	0.3548	0.4254	0.3612	0.0046	0.3525
CH ₄	0.5332	0.5312	0.4797	0.5453	0.0449	0.5332
C ₆ H ₆	0.0863	0.0862	0.0081	0.0709	0.7055	0.0863
C ₇ H ₈	0.0262	0.0260	0.0868	0.0212	0.2291	0.0262
C ₁₂ H ₁₀	0.0018	0.0018	0.0000	0.0014	0.0161	0.0018

Stream name	coolout	liq	gas	purge	v4out	grecycle
Temperature [C]	45.0000	45.0000	45.0000	45.0000	43.6108	45.0000
Pressure [psia]	471.0000	471.0000	471.0000	471.0000	371.0000	471.0000
Molar flow [kgmole/hr]	2054.9816	225.2213	1829.7603	218.1257	218.1257	1611.6346
H ₂ mole fraction	0.3525	0.0046	0.3954	0.3954	0.3954	0.3954
CH ₄	0.5332	0.0448	0.5933	0.5933	0.5933	0.5933
C ₆ H ₆	0.0863	0.7053	0.0101	0.0101	0.0101	0.0101
C ₇ H ₈	0.0262	0.2292	0.0012	0.0012	0.0012	0.0012
C ₁₂ H ₁₀	0.0018	0.0160	0.0000	0.0000	0.0000	0.0000

Table A.2 Continued

Stream name	dischg	p1out	toquench	toC1	v17out	d1
Temperature [C]	66.1190	45.1998	45.1998	45.1998	45.3400	154.6320
Pressure [psia]	575.0000	530.0000	530.0000	530.0000	486.0000	99.2058
Molar flow [kgmole/hr]	1611.6346	225.2213	49.7100	175.5113	49.7100	132.4104
H ₂ mole fraction	0.3954	0.0046	0.0046	0.0046	0.0046	0.0060
CH ₄	0.5933	0.0448	0.0448	0.0448	0.0448	0.0594
C ₆ H ₆	0.0101	0.7053	0.7053	0.7053	0.7053	0.9342
C ₇ H ₈	0.0012	0.2292	0.2292	0.2292	0.2292	0.0003
C ₁₂ H ₁₀	0.0000	0.0160	0.0160	0.0160	0.0160	0.0000
Stream name	v6out	d2	v7out	b2	p3out	v9in
Temperature [C]	153.5665	55.5611	53.8299	153.2194	153.5008	153.5008
Pressure [psia]	89.0700	89.0677	39.0677	89.3577	138.8400	138.8400
Molar flow [kgmole/hr]	132.4104	9.4222	9.4222	146.9382	146.9382	122.9882
H ₂ mole fraction	0.0060	0.0849	0.0849	0.0000	0.0000	0.0000
CH ₄	0.0594	0.8351	0.8351	0.0000	0.0000	0.0000
C ₆ H ₆	0.9342	0.0800	0.0800	0.9996	0.9996	0.9996
C ₇ H ₈	0.0003	0.0000	0.0000	0.0004	0.0004	0.0004
C ₁₂ H ₁₀	0.0000	0.0000	0.0000	0.0000	0.0000	0.0000
Stream name	v10in	v9out	b1	p2out	v12in	v13in
Temperature [C]	153.5008	90.6625	200.4386	200.9370	200.9370	200.9370
Pressure [psia]	138.8400	20.0000	102.2516	190.5000	190.5000	190.5000
Molar flow [kgmole/hr]	23.9500	122.9882	488.2509	488.2509	43.1009	445.1500
H ₂ mole fraction	0.0000	0.0000	0.0000	0.0000	0.0000	0.0000
CH ₄	0.0000	0.0000	0.0000	0.0000	0.0000	0.0000
C ₆ H ₆	0.9996	0.9996	0.0015	0.0015	0.0015	0.0015
C ₇ H ₈	0.0004	0.0004	0.9336	0.9336	0.9336	0.9336
C ₁₂ H ₁₀	0.0000	0.0000	0.0649	0.0649	0.0649	0.0649
Stream name	v12out	cCR1in	cCR1out	hCR1in	hCR2in	boil1
Temperature [C]	142.8172	200.9251	239.4000	354.0000	214.6033	239.4000
Pressure [psia]	30.2800	137.6800	102.2500	481.0000	478.0000	102.2500
Molar flow [kgmole/hr]	43.1009	445.1500	445.1500	2054.9816	2054.9816	445.1500
H ₂ mole fraction	0.0000	0.0000	0.0000	0.3525	0.3525	0.0000
CH ₄	0.0000	0.0000	0.0000	0.5332	0.5332	0.0000
C ₆ H ₆	0.0015	0.0015	0.0015	0.0863	0.0863	0.0014
C ₇ H ₈	0.9336	0.9336	0.9336	0.0262	0.0262	0.9337
C ₁₂ H ₁₀	0.0649	0.0649	0.0649	0.0018	0.0018	0.0649

Table A.2 Continued

Stream name	cCR2in	cCR2out	hCR2out	d3	p4out	v3out
Temperature [C]	153.5086	155.0000	208.6253	137.5844	140.1228	140.2127
Pressure [psia]	108.6400	89.3580	475.0000	29.9938	625.0000	575.0000
Molar flow [kgmole/hr]	23.9500	23.9500	2054.9816	40.2961	40.2961	40.2961
H ₂ mole fraction	0.0000	0.0000	0.3525	0.0000	0.0000	0.0000
CH ₄	0.0000	0.0000	0.5332	0.0000	0.0000	0.0000
C ₆ H ₆	0.9996	0.9996	0.0863	0.0016	0.0016	0.0016
C ₇ H ₈	0.0004	0.0004	0.0262	0.9984	0.9984	0.9984
C ₁₂ H ₁₀	0.0000	0.0000	0.0018	0.0000	0.0000	0.0000

Stream name	b3	p5out	v15in	v16in	v15out	boil3
Temperature [C]	290.3913	290.5412	290.5412	290.5412	271.0681	291.9000
Pressure [psia]	30.5739	86.7800	86.7800	86.7800	20.5700	30.4480
Molar flow [kgmole/hr]	27.6018	27.6018	2.8048	24.7970	2.8048	24.7970
H ₂ mole fraction	0.0000	0.0000	0.0000	0.0000	0.0000	0.0000
CH ₄	0.0000	0.0000	0.0000	0.0000	0.0000	0.0000
C ₆ H ₆	0.0000	0.0000	0.0000	0.0000	0.0000	0.0000
C ₇ H ₈	0.0028	0.0028	0.0028	0.0028	0.0028	0.0028
C ₁₂ H ₁₀	0.9972	0.9972	0.9972	0.9972	0.9972	0.9972

Stream name	cCR3in	cCR3out	hCR3out
Temperature [C]	290.5513	291.9000	613.2173
Pressure [psia]	72.3900	30.4480	483.0000
Molar flow [kgmole/hr]	24.7970	24.7970	2054.9816
H ₂ mole fraction	0.0000	0.0000	0.3525
CH ₄	0.0000	0.0000	0.5332
C ₆ H ₆	0.0000	0.0000	0.0863
C ₇ H ₈	0.0028	0.0028	0.0262
C ₁₂ H ₁₀	0.9972	0.9972	0.0018

ศูนย์วิทยทรัพยากร
จุฬาลงกรณ์มหาวิทยาลัย

APPENDIX B

EQUIPMENT AND DATA SPECIFICATION OF COMPLEX HEAT- INTEGRATED HDA PLANT

Table B.1 Equipment data and specifications of complex heat-integrated HDA plant

Equipments	Specifications	Complex heat-integrated HDA plant	
		HIP5	HIP6
Reactor	Length (m)	17.374	17.374
	Diameter (m)	2.905	2.905
	Number of tube	1	1
Furnace	Tube volumn (m ³)	8.5	8.5
Cooler	Tube volumn (m ³)	8.5	8.5
Separator	Liquid volumn (m ³)	1.13	1.13
	Shell volumn (m ³)	14.16	14.16
	Tube volumn (m ³)	14.16	14.16
FEHE1	UA (kJ/C-h)	4.415 x 10 ⁵	3.079 x 10 ⁵
	Shell volumn (m ³)	14.16	14.16
	Tube volumn (m ³)	14.16	14.16
FEHE2	UA (kJ/C-h)	1.899 x 10 ⁵	2.160 x 10 ⁵
	Shell volumn (m ³)	14.16	14.16
	Tube volumn (m ³)	14.16	14.16
Reboiler Column 1 (CR1)	UA (kJ/C-h)	1.887 x 10 ⁵	4.253 x 10 ⁵
	Shell volumn (m ³)	14.16	14.16
	Tube volumn (m ³)	14.16	14.16
Reboiler Column 2 (CR2)	Shell volumn (m ³)	-	14.16
	Tube volumn (m ³)	-	14.16
	UA (kJ/C-h)	-	1.104 x 10 ⁴
Reboiler Column 3 (CR3)	Shell volumn (m ³)	14.16	14.16
	Tube volumn (m ³)	14.16	14.16
	UA (kJ/C-h)	1.150 x 10 ⁴	3538.88
Tank Bottom C1 (tank1)	Vessel volumn (m ³)	5.6145	5.6179
Tank Bottom C2 (tank2)	Vessel volumn (m ³)	-	1.3295
Tank Bottom C3 (tank3)	Vessel volumn (m ³)	0.4431	0.4425

VITA

Miss. Sumalee Hemnithi was born in Samutprakarn, Thailand on December 16, 1983. She graduated Bachelor Degree in department of Chemical Science from Srinakharintharawiroth University in 2005. After that she entered the Graduate School of Chulalongkorn University to pursue the Master of Engineering in Chemical Engineering and completed in 2009.



ศูนย์วิทยทรัพยากร
จุฬาลงกรณ์มหาวิทยาลัย