

การเลียนแบบตราสารสิทธิและกลยุทธ์การซื้อขายแบบแสวงหากำไร  
ที่มีต้นทุนด้านสภาพคล่องและต้นทุนจากการทำธุรกรรม

นางสาวกรกนก อติสุธาโกชน์

ศูนย์วิทยพัทธพยากร  
วิทยานิพนธ์นี้เป็นส่วนหนึ่งของการศึกษาตามหลักสูตรปริญญาวิทยาศาสตรมหาบัณฑิต  
สาขาวิชาการเงิน ภาควิชาการธนาคารและการเงิน  
คณะพาณิชยศาสตร์และการบัญชี จุฬาลงกรณ์มหาวิทยาลัย  
ปีการศึกษา 2552  
ลิขสิทธิ์ของจุฬาลงกรณ์มหาวิทยาลัย

**OPTION REPLICATION AND ARBITRAGE TRADING STRATEGY  
WITH LIQUIDITY AND TRANSACTION COSTS**

**MISS KORNKANOK ATISUTAPOTE**

**A Thesis Submitted in Partial Fulfillment of Requirements**

**for the Degree of Master of Science Program in Finance**

**Department of Banking and Finance**

**Faculty of Commerce and Accountancy**

**Chulalongkorn University**

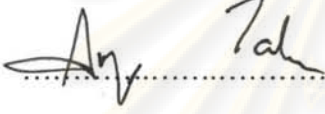
**Academic Year 2009**

**Copyright of Chulalongkorn University**

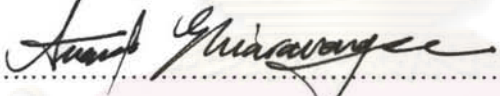
Thesis Title            OPTION REPLICATION AND ARBITRAGE TRADING  
                              STRATEGY WITH LIQUIDITY AND TRANSACTION COSTS  
By                         Miss Kornkanok Atisutapote  
Field of Study         Finance  
Thesis Advisor        Thaisiri Watewai, Ph.D.


---


Accepted by the Faculty of Commerce and Accountancy, Chulalongkorn  
University in Partial Fulfillment of the Requirements for the Master's degree

..... Dean of the Faculty of  
Commerce and Accountancy  
(Associate Professor Annop Tanlamai, Ph.D.)

THESIS COMMITTEE

..... Chairman  
(Anant Chiarawongse, Ph.D.)

..... Thesis Advisor  
(Thaisiri Watewai, Ph.D.)

..... External Examiner  
(Poomjai Nacaskul, Ph.D.)

กรรณก อติสุธา โภชน์ : การเลียนแบบตราสารสิทธิและกลยุทธ์การซื้อขายแบบแสวงหากำไรที่มีต้นทุนด้านสภาพคล่องและต้นทุนจากการทำธุรกรรม (OPTION REPLICATION AND ARBITRAGE TRADING STRATEGY WITH LIQUIDITY AND TRANSACTION COSTS) อ.ที่ปริกษาวิทยานิพนธ์หลัก: อ.ดร.ไทยศิริ เวทไว, 95 หน้า.

วิทยานิพนธ์ฉบับนี้ ทำการศึกษาราคาของตราสารสิทธิโดยการใช้กลยุทธ์แบบออฟติมอล ซึ่งเป็นการสร้างพอร์ตโฟลิโอเพื่อเลียนแบบมูลค่าของตราสารสิทธิโดยที่สินทรัพย์อ้างอิงมีความเสี่ยงด้านสภาพคล่องและต้นทุนการซื้อขาย กลยุทธ์นี้มีข้อดีคือ สามารถยืนยันได้ว่า มูลค่าของพอร์ตโฟลิโอนั้นจะไม่น้อยกว่าผลตอบแทนของตราสารสิทธิ ณ วันสุดท้าย โดยในการศึกษาใช้ข้อมูลราคาตราสารสิทธิจากตลาดอนุพันธ์แห่งประเทศไทย เนื่องจากการซื้อขายแบบต่อเนื่องไม่สามารถทำได้จริงในทางปฏิบัติ ดังนั้น ในการศึกษาจึงใช้กลยุทธ์การซื้อขายแบบแยกช่วงเวลา จากผลการศึกษาพบว่า ตัวแปรด้านสภาพคล่องนั้นมีค่าเป็นบวกและมีนัยสำคัญทางสถิติ ซึ่งสามารถตีความได้ว่า เส้นอุปทานนั้นมีลักษณะลาดเอียงขึ้นจากซ้ายไปขวา เส้นอุปทานนี้สอดคล้องกับทฤษฎีด้านเศรษฐศาสตร์จุลภาคและถูกสร้างขึ้นโดยที่ ราคาของสินทรัพย์อ้างอิงขึ้นอยู่กับประเภทของคำสั่งซื้อขายและขนาดของการซื้อขาย การศึกษาพบว่า ต้นทุนด้านสภาพคล่องมีผลกระทบต่อราคาของตราสารสิทธิมากกว่าต้นทุนจากการทำธุรกรรมในตลาดทุนไทย นอกจากนี้ ความแตกต่างของราคา ระหว่างราคาที่ได้จากการใช้แบบจำลองที่คำนึงถึงความเสี่ยงด้านสภาพคล่องและต้นทุนการซื้อขาย กับราคาตลาดของตราสารสิทธิในแต่ละสัญญาสามารถใช้แสวงหากำไรได้เมื่อราคาจากแบบจำลองต่ำกว่าราคาตลาด กลยุทธ์การซื้อขายแบบซื้อหุ้นและขายตราสารสิทธิถูกนำมาใช้ในตลาดของประเทศไทย จากผลการศึกษาแสดงถึง ผลกำไรที่มีค่าเป็นบวก ซึ่งหมายความว่า กลยุทธ์การซื้อขายนี้ประสบความสำเร็จ

ภาควิชา..... การธนาคารและการเงิน..... ลายมือชื่อนิสิต..... กระถาน ก

สาขาวิชา..... การเงิน..... ลายมือชื่ออ.ที่ปริกษาวิทยานิพนธ์หลัก..... (นพ) (น)

ปีการศึกษา 2552.....

# # 5182054926 : MAJOR FINANCE

KEYWORDS : Option Pricing/ Replicating Portfolio/ Trading Strategy / Liquidity Cost/  
Transaction Cost.

KORNKANOK ATISUTAPOTE : OPTION REPLICATION AND ARBITRAGE  
TRADING STRATEGY WITH LIQUIDITY AND TRANSACTION COSTS.  
THESIS ADVISOR : THAISIRI WATEWAI, Ph.D., 95 pp.

This study investigates the pricing of option by using the optimal hedging strategy for super-replicating an option in which the underlying asset is not perfectly liquid and there are transaction costs. The theoretical analysis and empirical evidence are conducted in the Thai option market. Since the continuous trading is impossible to implement in practice, discrete trading strategies are defined in this study. The optimal hedging strategy provides an advantage of assuring that the value of the replicating portfolio is not less than the option's liability at maturity. The empirical results reveal the significant positivity of the liquidity parameter which implies the upward-sloping of the supply curve. This supply curve is consistent with the market microstructure literature and assumes that the underlying security prices depend on trading volume and direction. This study finds that the liquidity cost has a bigger impact on the option prices than the transaction cost in the Thai market. Moreover, the difference between model prices (with liquidity and transaction costs included) and actual market prices in each option series will allow us to implement an arbitrage trading strategy when the model prices are lower than the market prices. The trading strategy of buying stock and selling the option will be exploited in the Thai market. The results show some positive profits which means that this arbitrage trading strategy succeeds.

Department : Banking and Finance

Student's Signature Kornkanok

Field of Study : Finance

Advisor's Signature Thaisiri Watwani

Academic Year : 2009

## ACKNOWLEDGEMENTS

This work was supported by the Faculty of Commerce and Accountancy, Chulalongkorn University. Firstly, I would like to express profound gratitude to my advisor, Dr. Thaisiri Watwai, for his invaluable support, supervision, encouragement and useful suggestions throughout this study. I appreciate his assistance in choosing topic, getting started on thesis, writing reports, and correcting the MATLAB code. His continuous support and guidance enabled me to complete my work successfully. Furthermore, I would like to thank my committees, Dr. Anant Chiarawongse, and Dr. Poomjai Nacaskul for their useful comments and suggestions. I am also highly thankful to Mr. Teerachai Kriangsakpong and Ms. Maythisa Teerawajee for assisting me with the MATLAB coding. Moreover, I like to express gratitude to my parent and my sister for their love and support throughout my life. Lastly, I would like to thank all my friends who shared many experiences and helped me overcome my doubts. Without all these people's care and consideration, this paper would not be completed.



ศูนย์วิทยทรัพยากร  
จุฬาลงกรณ์มหาวิทยาลัย

# CONTENTS

	PAGE
Abstract in Thai.....	iv
Abstract in English.....	v
Acknowledgements.....	vi
Contents.....	vii
List of Tables .....	ix
List of Figures .....	x
Chapter I : Introduction.....	1
Chapter II : Literature review.....	3
Chapter III : Data and methodology.....	9
Data.....	9
Methodology.....	10
Self-financing trading strategy .....	10
Supply curve estimation.....	10
Transaction cost estimation.....	16
The multi-period binomial tree construction.....	16
Optimal discrete option hedging strategies.....	18
Chapter IV : Results.....	24
Empirical results.....	24
Liquidity parameter.....	24
Call option price.....	25
Chapter V : Arbitrage trading strategy.....	32
Strategy.....	32
Model prices vs. market prices.....	33
Findings.....	45
Chapter VI : Conclusion.....	55
References.....	56

	PAGE
Appendices.....	60
Appendix A .....	61
Appendix B .....	65
Appendix C .....	68
Appendix D .....	70
Appendix E .....	76
Appendix F .....	79
Appendix G .....	85
Appendix H .....	88
Biography.....	95



ศูนย์วิทยทรัพยากร  
จุฬาลงกรณ์มหาวิทยาลัย



## LIST OF TABLES

	<b>PAGE</b>
Table 1: Descriptive statistics of the daily return of SET50 and TDEX .....	13
Table 2: Descriptive statistics of SET50 and TDEX value .....	14
Table 3: Statistical data of the CRR model.....	18
Table 4: Summary statistics of alpha and mu.....	24
Table 5: Summary of percentage change in prices.....	31
Table 6: Summary statistics of monthly returns of SET50.....	39
Table 7: Summary of Profit/Loss in December, March and June .....	46
Table 8: Summary of average transaction cost, liquidity cost and diff.....	51
Table 9: The terms of SET50 index .....	61
Table 10: Summary of SET50 index options contract specifications.....	62
Table 11: Summary of ThaiDex SET50 ETF information .....	63
Table 12: Estimated option price of December 2008 series .....	65
Table 13: Estimated option price of March 2009 series .....	66
Table 14: Estimated option price of June 2009 series .....	67
Table 15: Expected profit of portfolio replication in December 2008 .....	70
Table 16: Expected profit of portfolio replication in March 2009 .....	71
Table 17: Expected profit of portfolio replication in June 2009 .....	72
Table 18: Profit/Loss of portfolio replication in December 2008 .....	73
Table 19: Profit/Loss of portfolio replication in March 2009 .....	74
Table 20: Profit/Loss of portfolio replication in June 2009 .....	75
Table 21: The difference between real and expected profit in December 2008 .....	76
Table 22: The difference between real and expected profit in March 2009 .....	77
Table 23: The difference between real and expected profit in June 2009 .....	78
Table 24: Total transaction costs in December trading .....	79
Table 25: Total transaction costs in March trading .....	80
Table 26: Total transaction costs in June trading .....	81
Table 27: Total liquidity costs in December .....	82
Table 28: Total liquidity costs in March .....	83
Table 29: Total liquidity costs in June .....	84

## LIST OF FIGURES

	<b>PAGE</b>
Figure 1: Example of TDEX tick data.....	12
Figure 2: The daily return between SET50 index and TDEX.....	13
Figure 3: Value of SET50 index and TDEX.....	14
Figure 4: Daily returns between SET50 index and TDEX.....	15
Figure 5: Number of each transaction size of TDEX.....	15
Figure 6: Frequency of stock price process in one day (N=5).....	17
Figure 7: The binomial tree diagram of stock price process.....	20
Figure 8: The number of stock holding and money account in each scenario.....	20
Figure 9: Plot of estimated alpha parameter.....	25
Figure 10: Comparing at-the-money call option prices in December series.....	26
Figure 11: Comparing at-the-money call option prices in March series.....	26
Figure 12: Comparing at-the-money call option prices in June series.....	27
Figure 13: Comparing in-the-money call option prices in December series.....	28
Figure 14: Comparing in-the-money call option prices in March series.....	28
Figure 15: Comparing in-the-money call option prices in June series.....	29
Figure 16: Comparing out-of-the-money call option prices in December series.....	29
Figure 17: Comparing out-of-the-money call option prices in March series.....	30
Figure 18: Comparing out-of-the-money call option prices in June series.....	30
Figure 19: The price matching in the multi-period binomial tree diagram.....	33
Figure 20: Prices of at-the-money call option in December series.....	34
Figure 21: Prices of at-the-money call option in March series.....	34
Figure 22: Prices of at-the-money call option in June series.....	35
Figure 23: Prices of in-the-money call option in December series.....	35
Figure 24: Prices of in-the-money call option in March series.....	36
Figure 25: Prices of in-the-money call option in June series.....	36
Figure 26: Prices of out-of-the-money call option in December series.....	37
Figure 27: Prices of out-of-the-money call option in March series.....	37
Figure 28: Prices of out-of-the-money call option in June series.....	38
Figure 29: The percentage change of one-month SET50 index.....	39
Figure 30: Prices of at-the-money call option in December series ( $\sigma=0.1$ ).....	40

Figure 31: Prices of at-the-money call option in March series ( $\sigma=0.1$ ).....	40
Figure 32: Prices of at-the-money call option in June series ( $\sigma=0.1$ ).....	41
Figure 33: Prices of in-the-money call option in December series ( $\sigma=0.1$ ).....	41
Figure 34: Prices of in-the-money call option in March series ( $\sigma=0.1$ ).....	42
Figure 35: Prices of in-the-money call option in June series ( $\sigma=0.1$ ).....	42
Figure 36: Prices of out-of-the-money call option in December series ( $\sigma=0.1$ ).....	43
Figure 37: Prices of out-of-the-money call option in March series ( $\sigma=0.1$ ).....	43
Figure 38: Prices of out-of-the-money call option in June series ( $\sigma=0.1$ ).....	44
Figure 39: Profit/loss comparing with and without DIFF in December.....	47
Figure 40: Profit/loss comparing with and without DIFF in March.....	47
Figure 41: Profit/loss comparing with and without DIFF in June.....	48
Figure 42: Profit/Loss decomposition of 1-month trading in December.....	49
Figure 43: Profit/Loss decomposition of 1-month trading in March.....	49
Figure 44: Profit/Loss decomposition of 1-month trading in June.....	50
Figure 45: Total transaction costs of daily-rebalancing portfolio during December.....	51
Figure 46: Total transaction costs of daily-rebalancing portfolio during March.....	52
Figure 47: Total transaction costs of daily-rebalancing portfolio during June .....	52
Figure 48: Total liquidity costs of daily-rebalancing portfolio during December...	53
Figure 49: Total liquidity costs of daily-rebalancing portfolio during March.....	53
Figure 50: Total liquidity costs of daily-rebalancing portfolio during June.....	54
Figure 51: The amount of Profit/ Loss decomposition in December.....	68
Figure 52: The amount of Profit/ Loss decomposition in March.....	68
Figure 53: The amount of Profit/ Loss decomposition in June.....	69
Figure 54: Total transaction costs in December with strike price=310.....	85
Figure 55: Total transaction costs in March with strike price=330.....	85
Figure 56: Total transaction costs in June with strike price=460.....	86
Figure 57: Total liquidity costs in December with strike price=310.....	86
Figure 58: Total liquidity costs in March with strike price=330.....	87
Figure 59: Total liquidity costs in June with strike price=460.....	87

# CHAPTER I

## INTRODUCTION

Traditional option pricing theories assume perfectly liquid and frictionless markets for underlying assets. In reality, however, markets substantially diverge from these unrealistic assumptions because there are bid-ask spreads and transaction fees for trading underlying assets. Many theoretical and empirical studies support that liquidity and transaction costs significantly affect option values. For example, Çetin, Jarrow, Protter, and Warachka (2006) conclude that liquidity costs for trading the underlying assets are a significant component of the option price and increase quadratically in the number of options being hedged, and Loeb (1983) documents that the costs of trading is significant. The impact of liquidity and transaction costs on option prices is especially large for emerging markets where the underlying assets are typically not highly liquid.

In this study, we will introduce liquidity and transaction costs into an option pricing model. In particular, the binomial option pricing model with liquidity and transaction costs is developed to obtain the replicating portfolio whose value is the option fair price. This portfolio is constructed by super-replicating the payoff of the option at maturity. This “super-replication” strategy has an advantage of assuring that the replicating portfolio is not worth less than the option’s liability at maturity. The dynamic programming and backward recursion will be used to solve for the optimal replicating portfolio. The liquidity cost is incorporated via a stochastic supply curve. This supply curve provides the relationship between the trade size and the stock price, which is assumed to follow a geometric Brownian motion. The proportional transaction fee is also included in the model.

Moreover, this paper will implement the model to take the benefit from the existing arbitrage opportunities. The developed model with liquidity and transaction costs will be used to determine the option fair price. Then by comparing the model price with the market price, the trading strategy will be executed if the model price is less than the market price by shorting the overpriced option and super-replicating its payoff. Afterward, the replicating portfolio is constructed and rebalanced every day. On the last day of trade, which is the option’s maturity date, we check whether the arbitrage trading strategy works by looking at the portfolio value compared to the option’s payoff.

In this study, we focus on European call options in the Thai market whose underlying asset is the SET50 index (more details about SET50 index and options on SET50 index are available in Appendix A). This differs from many other works that study related issues in developed markets. In addition, our study, to the best of our knowledge, is the first study that includes both liquidity and transaction costs in the option pricing model for the Thai market. This allows us to try an arbitrage trading strategy in the option and stock markets.



ศูนย์วิจัยทรัพยากร  
จุฬาลงกรณ์มหาวิทยาลัย

## **CHAPTER II**

### **LITERATURE REVIEW**

The traditional Binomial and Black-Scholes pricing models are widely used in option valuation. These models price options based on the replicating portfolio approach. In particular, a portfolio which replicates the payoff of the option contract at maturity is constructed using a combination of underlying assets and a risk-free bond. This portfolio requires dynamic rebalancing to perfectly replicate the option's payoff and assumes that the changes in the asset price follow a geometric Brownian motion. There are many alternative models that are built on other processes. For instance, the constant elasticity of variance (CEV) model which assumes a different diffusion process instead of the geometric Brownian motion; a mixed jump-diffusion model (Merton (1976)) which combines the continuous asset price changes with jumps; and a pure jump model called Variance-Gamma model (Carr, Chang, and Madan (1998)). These models are formulated under two primary assumptions: the market for underlying assets is frictionless and the continuous trades are possible. However, in the real world, the markets are imperfect and continuous trading is impossible. That is, there are bid-ask spreads and transaction fees for trading underlying assets. In order to relax the standard assumptions and make them more realistic, this study will introduce the liquidity and transaction costs for the underlying security market into the model and develop a discrete trading strategy. We will investigate the option prices with the presence of liquidity and transaction costs and then use the developed model to check the existence of arbitrage opportunities in the Thai option market.

There are many literatures studying the arbitrage pricing theory with transaction costs. The importance of trading costs is illustrated in Loeb (1983). His study considers the trading costs in actual market using a sample of Wilshire 5000 in the U.S. equity market. A typical transaction of this stock causes an overall transaction cost approximately 4%. He found that the components of the trading costs, which are bid-ask spread, price concession and brokerage fee, are highly correlated. The transaction cost is not only important in the magnitude in actual data but it is also a significant factor in the portfolio selection (Constantinides (1986), Grennotte and Jung (1994) and Grossman and Laroque (1990)). Moreover, the article of Vayanos (1998) also reveals that transaction

costs have large effects on investors' trading strategy and turnover but very small effects on stock prices. As a result, we can conclude that the transaction cost is a major cost of investors that cannot be ignored.

The issues of option pricing with transaction costs for the underlying assets have been discussed by many works in the literature. The problem of hedging call and put options in the presence of proportional transaction costs is considered by Leland (1985) and Boyle and Vorst (1992). Leland (1985) develops the Black-Scholes model with a modified option replicating strategy. This strategy depends on the size of transaction costs and the frequency of trading revision. On the other hand, the study of Boyle and Vorst (1992) has extended the Cox-Ross-Rubinstein binomial option pricing model by introducing the proportional transaction costs. Our approach is quite coherent with Boyle and Vorst (1992) in the context of employing the binomial option pricing model but the details of stock price process and other limitations are generally different.

Other related papers in the context of transaction costs are the studies of Edirisinghe, Naik and Uppal (1993), Bensaid, Lesne, Pagès and Scheinkman (1992) and Figlewski (1989). These studies, which are similar to our model, exploit the arbitrage option pricing approach which is independent of preferences and probability beliefs of each individual investor. Moreover, these papers conclude that the transaction cost significantly affects the option valuation. In particular, Edirisinghe, Naik and Uppal (1993) find the least cost strategies that manufacture a payoff that is at least as large as the desired one when there are fixed and variable transaction costs and lot size constraints on trading. They show that in the presence of trading frictions, it is no longer optimal to revise one's portfolio in each period. In the study of Bensaid, Lesne, Pagès and Scheinkman (1992), they consider the discrete time approach to address the problem of finding the optimal strategy in derivative asset pricing with the proportional transactions costs. They construct an alternative dynamic programming to obtain the cost-minimizing trading strategy. The price interval is derived by setting up the upper and lower bounds. The upper bound is the minimum amount of an initial investment which, at least, is equal to the value of the derivative asset. The lower bound is the maximum amount of an initial borrowing. However, because trading is costly, investor may pay to weigh the benefits of replication against the savings on transaction costs. They show that in the presence of transaction costs, the replicating strategy is no longer the cheapest way to hedge the call option.

Figlewski (1989) tries to apply the arbitrage option valuation model to the actual imperfect market. He simulates the price data to examine the performance of options hedging strategies and applies Monte Carlo simulations to determine the effect of some of the market imperfections: uncertain volatility, transaction costs, indivisibilities, and rebalancing at the discrete time intervals. The empirical results show that using the standard arbitrage trading strategy (based on the Black-Scholes model), transactions costs are large even being done by a market maker. Moreover, the less-frequency trading strategies do not help much to reduce the transactions costs and the daily hedging also has a considerable impact on its risk. However, Dumas and Luciano (1991) have argued the work of Figlewski (1989) that, in the presence of transactions costs, the using of a replicating argument in Figlewski (1989) would not provide the right option price. Instead, they propose that it would be more appropriate to analyze the trading strategy of an investor who acts as a trader in the asset market and as a dealer in the option market.

In the context of liquidity cost, this cost has recently been incorporated into the arbitrage pricing theory. The early arbitrage pricing theory introduces the liquidity risk by using the convenience yield approach. In Jarrow and Turnbull (1997), they provide the approach to pricing and hedging London Inter-bank Offer Rate (LIBOR) derivatives. This approach incorporates the liquidity premium for estimating recovery rate and default probabilities inherent in debt and equity market prices. The liquidity risk is combined into the arbitrage pricing theory using the notion of convenience yield. The convenience yield is an implication of adding short sale constraints on Treasury securities. It has a long history in the context of commodity pricing. However, this convenience yield approach has a significant limitation that it does not explicitly capture the impact of different trade sizes on the price, whereas all markets experiences the price inelasticities and bid/ask spreads. Jarrow (2001) applies the approach in Jarrow and Turnbull (1997) to develop the model for pricing and hedging of derivatives on the Eurodollar term structure. Nevertheless, the validity of the model awaits empirical testing.

However, Cetin, Jarrow and Protter (2004) provide the liquidity risk model that overcomes the limitation of the convenience yield approach. They extend the classical approach of arbitrage pricing theory by taking into account the liquidity risk. This inclusion of liquidity risk model incorporates the impact of differing trade sizes on the security's price. In this approach, a stochastic supply curve for stock prices will be introduced as a function of trade size (number of shares) and direction (buy or sell) of a



transaction. The stock price follows a geometric Brownian motion which similar to the work of Cheridito (2003) that constructs a model of arbitrage trading strategies whose discounted price follows a fractional Brownian motion with drift. In the context of continuous trading strategy, the necessary and sufficient conditions on the evolution of supply curve are specified to ensure that there are no arbitrage opportunities in the economy. In the conclusion, they state that there is no liquidity cost when replicating an option's payoff using a continuous trading strategy of finite variation. As a result, the option price will be equal to the arbitrage-free price in the classical economy which assumes an infinitely liquid market. Chen, Stanzl and Watanabe (2001) also examine the impact of illiquidity on the subsequent transaction prices by using the coherent mathematical model but they do not consider the price impact of trade.

Furthermore, Cetin, Jarrow, Protter and Warachka (2006) model the liquidity risk as a stochastic supply curve which assumes that the transaction price is a function of the trade size. They continue the work of Cetin, Jarrow and Protter (2004) and develop the formula used to estimate the liquidity cost when the discrete trading strategy is performed. For comparative purpose, they implement two methodologies: the optimal discrete hedging strategy and non-optimal discrete Black-Scholes hedging strategy. The empirical results demonstrate that the optimal hedging strategy often has lower liquidity cost as comparing to Black-Scholes strategy. A significant liquidity cost intrinsic to every option, even under the optimal hedging strategy. Our study mainly follows the procedures developed by this article in the notion of liquidity; however, we introduce the additional transaction cost limitation to the model and the multi-period binomial pricing approach will be employed.

Other related papers which present some interesting evidences are the studies of Bank and Baum (2004) and Liu and Yong (2005). Both of these studies introduce the assumption that traders can affect the underlying price when the market is illiquid. The study of Bank and Baum (2004) considers the hedging strategies in financial markets with a large trader. They provide the real wealth dynamics process using the Itô-Wentzell formula to prove the absence of arbitrage for the large investor. A general continuous time model for an illiquid financial market is introduced and market prices can be changed by a single trade of large trader. This approach reveals that a large investor should use the continuous trading strategies of bounded variation to avoid transactions costs caused by illiquidity. A large investor model applies many properties of traditional

small investor model because these assumptions are also suitable and approximately attainable in the large investor setting. Hence, it allows the large investor to obtain the same utility as the small investor does. This result also supports the approximation finding in Levental and Skorohod (1997). However, we do not include such large traders in our analysis.

Liu and Yong (2005) propose that an option trader, who is trading in the underlying asset for replicating the option's payoff, can affect the underlying asset price when the market is imperfectly liquid. They examine how this imperfect liquidity affects the replication of European call option. To compute a replicating cost of European option, a nonlinear Black-Scholes model is derived. They show that in the presence of adverse price impact, the replicating costs increase. Unlike the presence of transaction cost, the cost of super-replication is higher than the exact option replication. As a result, compared to the Black-Scholes model, a trader will buy (sell) more stocks to replicate a call (put) option and the excess replicating cost is approximately quadratic in the number of unit of option being replicated. This article is similar to our study that allows the price of the underlying asset to move when there is a trade in the underlying asset.

There are studies investigating these issues in other markets instead of the renowned U.S. market. For instance, Brenner, Eldor and Hauser (2001) examine the effect of illiquidity on the value of currency options in the Israeli currency market. They find that the non-tradable options are discounted in price about 21 percent, on average, less than the exchange-traded options. This discount is a function of the cost of replicating the illiquid option. Furthermore, the liquidity risk is also investigated by using other procedures such as a fuzzy measure theory. This method is introduced by Cherubini and Lungu (2001). They try to incorporate the liquidity risk into the corporate claim evaluation using the fuzzy measure theory. The corporate claim represents a derivative asset whose underlying is the value of the asset of the firm. The fuzzy measure can be easily used to extend the available asset pricing model, in the case of an illiquid market. Using this technique, they show that the credit risk and liquidity risk are positively correlated. This finding conforms to the study of Ericsson and Renault (2001) which develops a simple binomial model of liquidity and credit risk on the yield spreads of corporate bond. They show that the liquidity spreads are an increasing function of the volatility of the firm's assets and leverage, which in accordance with the study of Amihud and Mendelson (1991). In addition, there are several articles taking into account the

liquidity in their studies in many issues such as the studies of Chordia, Roll and Subrahmanyam (2002), Acharya and Pedersen (2005) and Roger and Zane (1998).

Chordia, Roll and Subrahmanyam (2002) study the determinants and properties of order imbalance and the relations of the imbalance between buyer-initiated and seller-initiated orders on liquidity and market returns over a long sample period of NYSE stocks. The study shows that the quoted spreads (liquidity) is higher if the order is more imbalanced. Liquidity is predictable by using the market returns. That is, when market declines in this period, liquidity falls in the next period and vice versa.

Acharya and Pedersen (2005) introduce a liquidity-adjusted capital asset pricing model (CAPM) and provide how several channels of liquidity risk can affect asset prices. They decompose and estimate the effect of liquidity risk into three kinds of risk: cohesion in liquidity with the market liquidity, return sensitivity to market liquidity and liquidity sensitivity to market returns. The model shows that liquidity moves in the same direction with returns and can predict future returns.

Roger and Zane (1998) establish the simple expansion for the optimal solution with two different liquidity-constrained investment decisions. The investor who may invest in a riskless bank account and a share is considered and allowed to readjust his portfolio between the two assets at the times of a Poisson process. The two investment problems are different due to the different assumptions of fixed and variable consumption rate of an agent who is trying to maximize the expected utility of consumption. This study can infer that the cost of liquidity is inversely proportional to the intensity of the Poisson process.

In brief, our paper extends the classical approach by formulating a new model that takes into account the liquidity and transaction costs constraints. Specifically, we study the multi-period binomial option pricing model of a European call option on a stock index by using the portfolio replication technique. The dynamic programming and backward recursion will be used to solve for the optimal replicating portfolio. This paper is also trying to implement an arbitrage trading strategy in the Thai option market whose data is available to us. To the best of our knowledge, there are no any literatures studying the topic of pricing options with both transaction and liquidity costs for the Thai market before.

## CHAPTER III

### DATA AND METHODOLOGY

#### A. Data

The main purposes in this study are to investigate the liquidity and transaction costs incurred when constructing the replicating portfolio with discrete trading strategies and to provide an example of implementing an arbitrage trading strategy to the real trading process in the Thai market. Since the SET50 index which is the underlying asset in our study is a non-tradable index, we use the TDEX SET50 Index ETF which tries to replicate the return of the SET50 Index as a proxy to obtain the liquidity of the underlying asset.

We collect TDEX SET50 Index ETF by tick data including prices and trading volumes during August 1, 2008 to November 28, 2008 with 21,354 samples to estimate daily liquidity parameter ( $\alpha$ ). The average liquidity estimation is conducted over the four-month period with 84 trading days. All data in this study is obtained from the Reuters application.

We use both daily historical and implied volatilities to construct binomial trees in this study. In particular, the average daily historical volatility during August 1, 2008 to November 28, 2008 and the average daily implied volatility with less than 1-month maturity over September 1 to 30, 2008 are used as the volatility of the underlying asset.

The contracts of SET 50 index call options in this study are considered in three maturities: December 2008, March 2009 and June 2009. All the options data is collected from the TFEX website. The daily prices of the options are collected for one month before their maturities: for options maturing in December 2008, we collect the daily option price for each strike price during December 1 to 29, 2008; for options maturing in March and June 2009, we collect the data during March 2 to 30, 2009 and June 1 to 29, 2009 respectively.

The daily closing prices of SET50 are collected from December 1, 2008 to June 30, 2009 for constructing a tree diagram. The daily bid-ask prices of TDEX are used during December 2008, March and June 2009 to investigate an arbitrage trading strategy in the market.

## B. Methodology

### 1. Self-financing Trading Strategy

The trading strategy is the one defined by Cetin, Jarrow and Protter (2004) and will be used in the subsequent analysis. The trading strategy is summarized as  $(X_t, Y_t : t \in [0, T], \tau)$  where  $X_t$  represents the trader's aggregate stock holding at time  $t$  (units of the stock),  $Y_t$  represents the trader's aggregate money market account position at time  $t$  (units of money market account),  $T$  represents the maturity date, and  $\tau$  represents the liquidation time of the stock position in the replicating portfolio. The trading strategy is subject to certain restrictions.

Firstly, the trading strategy must be a predictable process that starts with zero units of both the stock and money market account and returns to zero units of the stock at time  $T$ . This predictability condition insures that the trader cannot look ahead in time to construct his stock position. The accumulated success or failure of trading strategy can be noticed in the magnitude of  $Y_T$ . Secondly, the stock position can be liquidated prior to time  $T$ . This will ensure that the round-trip liquidity costs are incurred. By construction, this particular self-financing trading strategy generates no cash flows for all time  $t \in [0, T]$ . That is, the purchase (sales) of the stock must be obtained via borrowing (investing) in the money market account.

### 2. Supply Curve Estimation

In Cetin, Jarrow and Protter (2004), the existence of a stochastic supply curve is hypothesized as a function of trade size. Specifically, the size and direction of a transaction is used to determine the price of stock. The liquidity cost is a critical factor that affects the shape of the supply curve. The greater an asset's liquidity, the more horizontal its supply curve. To value a European call option in the presence of illiquid economy, we assume the stock's supply curve satisfies

$$S(t, x) = e^{\alpha x} S(t, 0) \text{ with } \alpha > 0 \quad (1)$$

where

$$S(t, 0) \equiv \frac{S_t}{e^{rt}} = \frac{S_0 e^{\mu t + \sigma W_t}}{e^{rt}} \quad (2)$$

for constant drift  $\mu$  and volatility  $\sigma$ , with  $W_t$  denoting a standard Brownian motion,  $S_t$  denotes stock price at time  $t$ ,  $S(t, x)$  represents the transaction price, per share, at time  $t \in$

$[0, T]$  that a trader pays/receives for order flow  $x$  normalized by the value of a money market account where a positive order ( $x > 0$ ) represents a buy, a negative order ( $x < 0$ ) represents a sale and  $x=0$  corresponds to the marginal trade,  $\alpha$  is the liquidity cost parameter, and  $r$  represents the spot rate of interest.

Equation (2) states that the marginal stock price  $S(t, 0)$  follows a geometric Brownian motion, while the extended Black-Scholes economy's supply curve is given in equation (1). It is important to emphasize that the supply curve given in expression (1) is stochastic. After a trade is executed, a new supply curve  $S(t, x)$  is generated for subsequent trades.

A simple regression methodology is employed to estimate the liquidity parameter  $\alpha$  in equation (1). Let  $\tau_i$  denote the time index with corresponding order flow  $x_{\tau_i}$  and stock price  $S(\tau_i, x_{\tau_i})$  for every transaction  $i = 1, \dots, N$  in a given day. Thus, we are led to the following regression specification

$$\ln\left(\frac{S(\tau_{i+1}, x_{\tau_{i+1}})}{S(\tau_i, x_{\tau_i})}\right) = \alpha(x_{\tau_{i+1}} - x_{\tau_i}) + \mu(\tau_{i+1} - \tau_i) + \sigma\mathcal{E}_{\tau_{i+1}, \tau_i} \quad (3)$$

where the error  $\mathcal{E}_{\tau_{i+1}, \tau_i}$  can be written as  $\varepsilon\sqrt{\tau_{i+1} - \tau_i}$  with  $\varepsilon$  being distributed  $N(0, 1)$ . Observe that the left side of equation (3) is the log-return between two consecutive trades and this expression reduces to a standard geometric Brownian motion when  $\alpha$  is identically zero.

To determine whether a given transaction is completed by a buy or sell order, we follow the algorithm proposed in Lee and Ready (1991). Specifically, we suppose that the order flow  $x_{\tau_{i+1}}$  is positive (buy) if  $S_{\tau_{i+1}} > S_{\tau_i}$ , and the order flow  $x_{\tau_{i+1}}$  is negative (sell) if  $S_{\tau_{i+1}} < S_{\tau_i}$ . If  $S_{\tau_{i+1}} = S_{\tau_i}$ , we assume that  $x_{\tau_{i+1}}$  has the same sign as  $x_{\tau_i}$ . Figure 1 below illustrates some raw data used in the regression (3).

RAW DATA				REVISED DATA				
Date (GMT)	Time ( $\tau_{i+1}$ )	price ( $S(\tau_{i+1}, x_{\tau_{i+1}})$ )	Volume	Buy/sell	$x_{\tau_{i+1}}$	$\ln\left(\frac{S(\tau_{i+1}, x_{\tau_{i+1}})}{S(\tau_i, x_{\tau_i})}\right)$	$x_{\tau_{i+1}} - x_{\tau_i}$	Time interval ( $\tau_{i+1} - \tau_i$ ) (seconds)
3/11/2008	2:56:30	3.1200	500	Buy	500	0.0064	-3765	21
3/11/2008	2:57:20	3.1100	50	Sell	-50	-0.0032	-550	50
3/11/2008	2:58:04	3.1100	950	Sell	-950	0.0000	-900	44
3/11/2008	2:58:26	3.1100	30	Sell	-30	0.0000	920	22
3/11/2008	2:59:09	3.1100	20	Sell	-20	0.0000	10	43
3/11/2008	2:59:14	3.1100	70	Sell	-70	0.0000	-50	5
3/11/2008	2:59:25	3.1200	250	Buy	250	0.0032	320	11
3/11/2008	2:59:35	3.1100	903	Sell	-903	-0.0032	-1153	10
3/11/2008	3:00:08	3.1100	198	Sell	-198	0.0000	705	33
3/11/2008	3:01:10	3.1100	80	Sell	-80	0.0000	118	63
3/11/2008	3:01:33	3.1100	10	Sell	-10	0.0000	70	23
3/11/2008	3:01:38	3.1100	30	Sell	-30	0.0000	-20	5
3/11/2008	3:01:59	3.1100	5	Sell	-5	0.0000	25	21

**Figure 1: Example of TDEX tick data**

For any discrete trading strategy, the liquidity cost equals

$$L_T = \sum_{j=0}^N [x_{\tau_{j+1}} - x_{\tau_j}] \times [S(\tau_j, x_{\tau_{j+1}}) - S(\tau_j, 0)] \quad (4)$$

It is important to emphasize that the liquidity cost of a transaction depends on both  $\alpha$  and the marginal stock price  $S(\cdot, 0)$ . To make it easier to implement, this study approximates liquidity cost for a small  $\alpha$  by using a Taylor series expansion of  $\exp\{\alpha(x_{\tau_{j+1}} - x_{\tau_j})\}$ . This implies that the terms in the summation in equation (4) are approximated by

$$[x_{\tau_{j+1}} - x_{\tau_j}] S(\tau_j, 0) [\exp\{\alpha(x_{\tau_{j+1}} - x_{\tau_j})\} - 1] \approx \alpha S(\tau_j, 0) [x_{\tau_{j+1}} - x_{\tau_j}]^2 \quad (5)$$

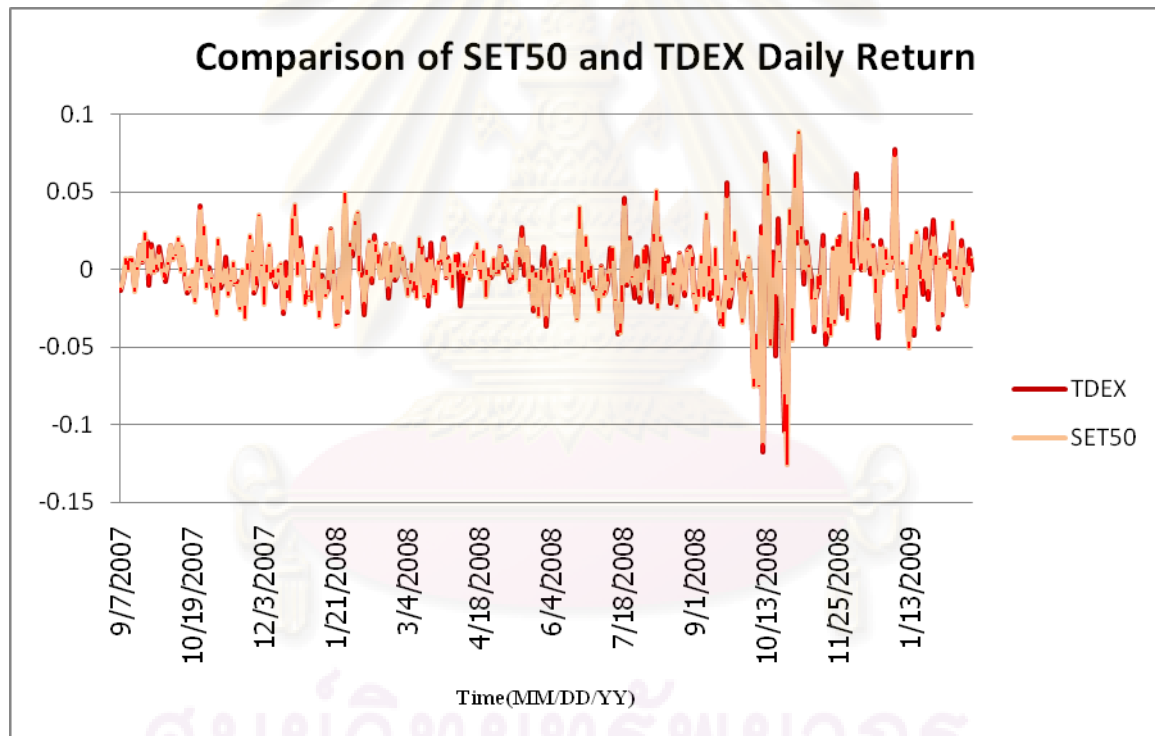
Note that one could estimate  $\alpha$  directly from the approximation given by equation (5). However, this would require marginal stock price  $S(t, 0)$  and the liquidity cost for each transaction which are difficult to obtain.

Since the SET50 index is a non-tradable security, this study uses TDEX as a proxy. TDEX is an exchange-traded fund established in Thailand. The objective of this fund is to achieve a price and yield performance similarly to that of the SET50 index. TDEX has provided the returns that very close to the return of SET50 index since the first launch on September 2007. The table and figure below show the daily return of SET50 index and TDEX. The average value of the absolute differences between SET50 index

and TDEX daily return is 0.4926%. The correlation between these two securities is 0.96 which means that they are highly correlated.

**Table 1:** Descriptive statistics of the daily return of SET50 and TDEX

	SET50	TDEX
Mean	-0.0018	-0.0018
Median	-0.0015	0.0000
Maximum Daily Return	0.0892	0.0876
Minimum Daily Return	-0.1256	-0.1178
Std. Dev.	0.0227	0.0225
Average value of the differences between SET50 index and TDEX daily return		0.0049
Correlation		0.9554



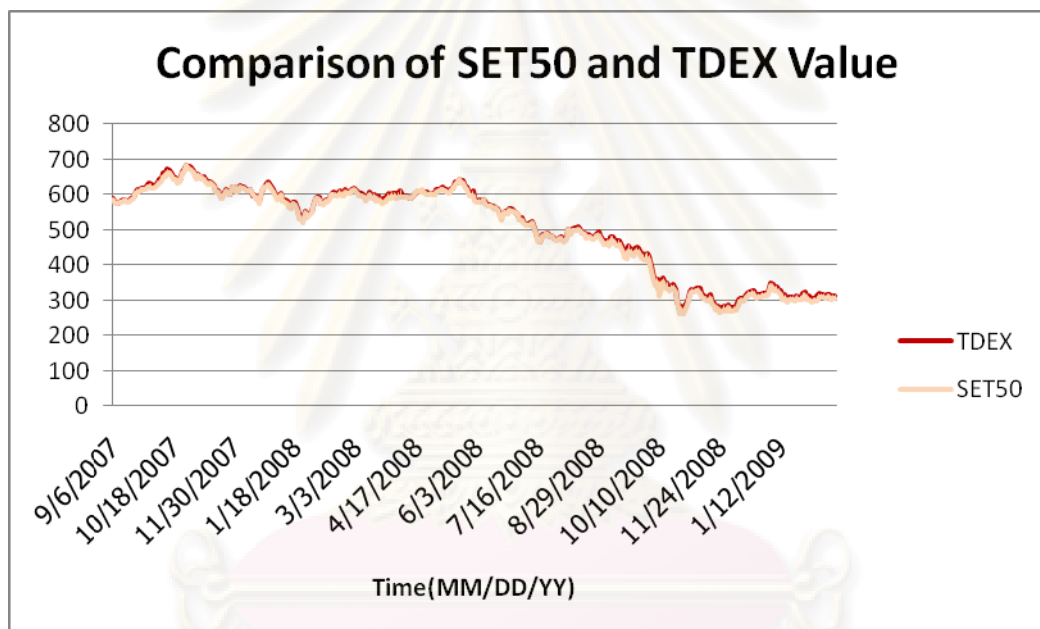
**Figure 2:** The daily return between SET50 index and TDEX

Table 2 and Figure 3 present the price level of SET50 index and TDEX. In this figure, the prices of TDEX are very close to the levels of SET50 index. The average value of the absolute differences between SET50 index and TDEX is approximately 6.35 points and the correlation between these two securities is almost 1. Since the tracking error of TDEX is very small, TDEX can be used as a good proxy for SET50 index.

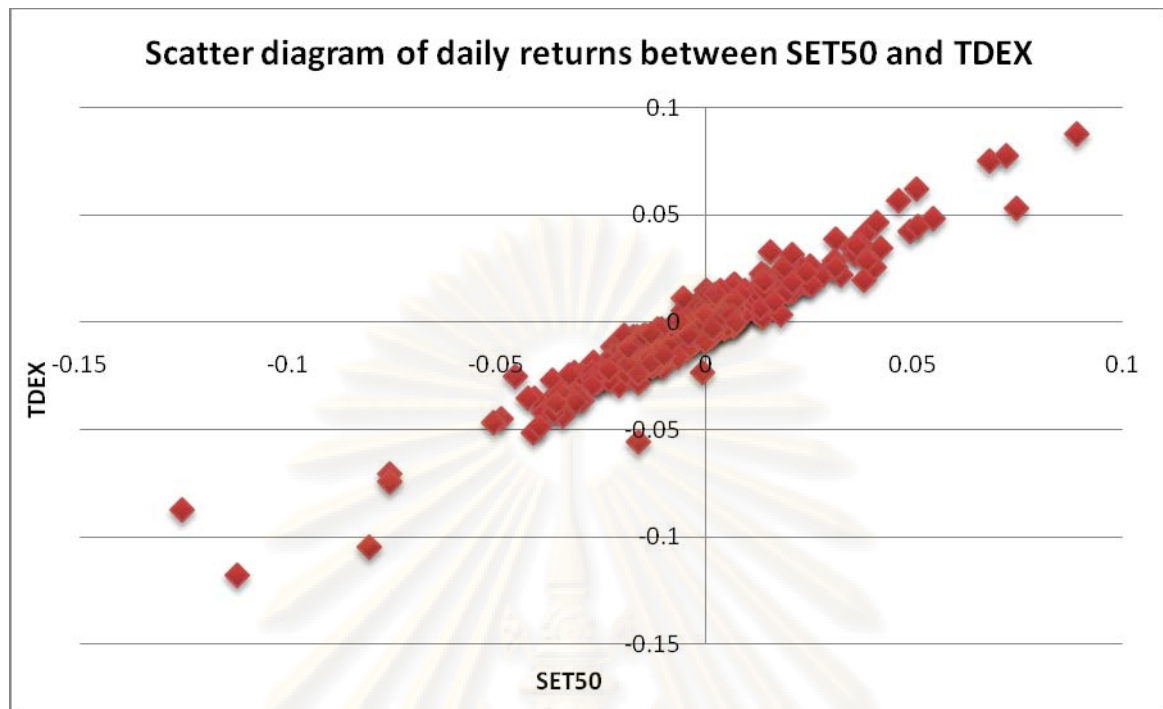


**Table 2: Descriptive statistics of SET50 and TDEX value**

	SET50	TDEX
Mean	501.0717	507.3492
Median	562.9850	567.0000
Maximum Value	681.8200	685.0000
Minimum Value	261.3000	274.0000
Standard Deviation	127.1331	125.4399
Average value of the differences between SET50 index and TDEX value		6.3466
Correlation		0.9997

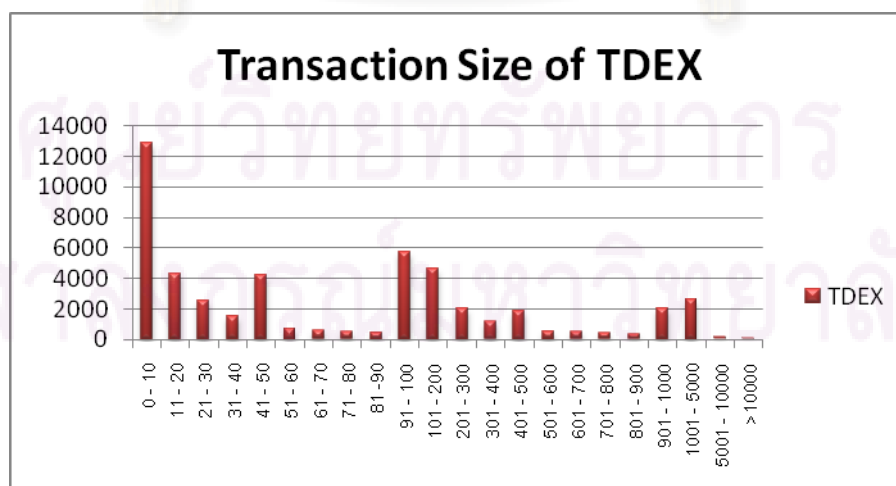
**Figure 3: Value of SET50 index and TDEX**

In Figure 4, the scatter plot of daily returns between SET50 and TDEX illustrates the positive relationship which almost follows the 45-degree line.



**Figure 4:** Daily returns between SET50 index and TDEX

The plot of the number of transaction for each range of transaction size (number of units per transaction) over the sample periods shows some interesting evidences. Precisely, TDEX has mostly been traded in small quantity i.e. less than 100 unit per trade. Note that 100 units of TDEX equal only 1 unit of SET50. The number of transactions with less than 10 units per transaction over the sample period is 12,897 which accounts for approximately 25.89%.



**Figure 5:** Number of each transaction size of TDEX

### 3. Transaction cost estimation

The trading cost will be charged on the change in the net stock position, whether buying or selling stocks. In Edirisinghe, Naik and Uppal (1993), the transaction cost can be divided into two types: variable cost and fixed cost. Let

$$R_T = \sum_{j=0}^M \left[ |x_{\tau_{j+1}} - x_{\tau_j}| \theta S(t, x) + \eta I(t, j) \right] \quad (6)$$

denote the total transaction cost where  $M$  is the number of periods considered,  $\eta$  denotes a fixed component to the trading costs and  $\theta$  is the variable component.  $I(t, j) = 0$  if  $x_{\tau_{j+1}} = x_{\tau_j}$ , and 1 otherwise. The investor who buys one share of stock when the stock price is  $S(t, x)$  pays  $S(t, x)(1+\theta) + \eta$ . On the other hand, when establishing a short position, the investor receives  $S(t, x)(1-\theta) - \eta$ .

However, this paper only concerns the variable costs because the rebalancing of replicating portfolio is based on the internet trading which has no fixed cost. The transaction costs of internet trading are defined by the stock exchange of Thailand (SET) as composed of two components. The first component is the commission fee given by  $(0.1\%)*(\text{number of share traded})*(\text{stock price per share})$ . The second component is 7% tax of the commission fee. Thus the value of  $\theta$  is equal to 0.00107. Moreover, there is no lot size effect because the  $\theta$  is constant for all transactions.

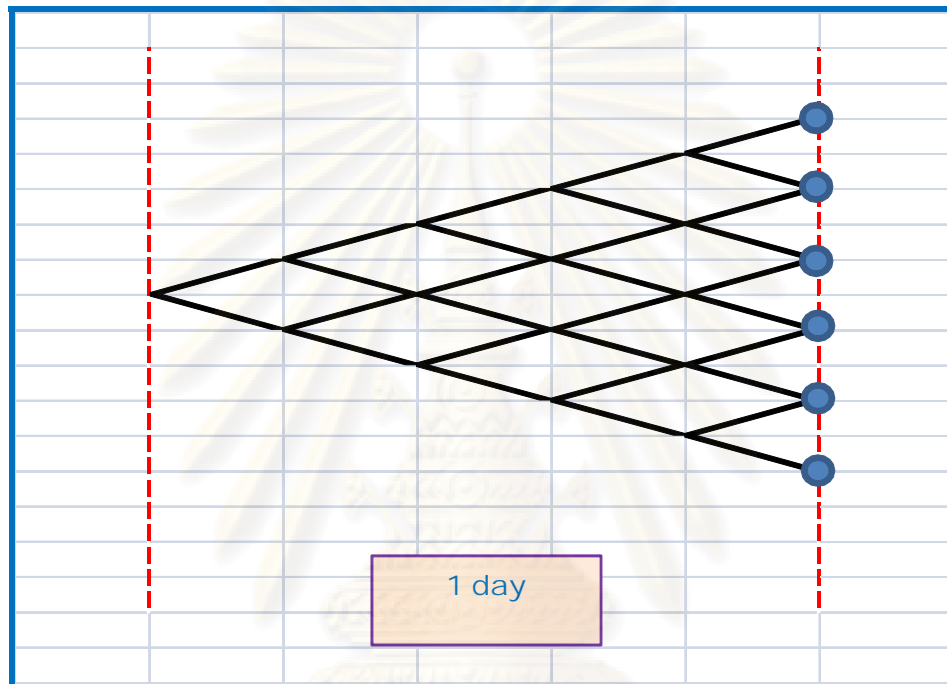
### 4. The multi-period binomial tree construction

The following offers a brief summary of the steps required to implement the dynamic programming procedure using a binomial stock price process. Consider a three-period binomial tree with an initial stock price at time 0 denoted by  $S$ , and  $U$  and  $D$  are the up and down factors (see Figure 4 below). At time 1, the stock price is either  $SU$  or  $SD$ . At time 2, the stock price could be any of  $SUU$ ,  $SUD$  or  $SDD$ . At time 3, which is the option's maturity date, the stock price has 4 possible scenarios:  $SUUU$ ,  $SUDU$ ,  $SUDD$  and  $SDDD$ . Note that the binomial tree in this study is a recombining tree. In the framework of the binomial tree of Cox, Ross and Rubinstien (1979), thereafter CRR, the up and down factors are as follow:

$$U = e^{\sigma \sqrt{\left(\frac{\Delta t}{N}\right)}}$$

$$D = e^{-\sigma \sqrt{\left(\frac{\Delta t}{N}\right)}}$$

where  $\sigma$  is the volatility and  $\Delta t$  is equal to 1 day. In this study, we allow price to move  $N$  times per day. For example, if we suppose that the price will go up or down for 5 times in one day,  $N$  is equals to 5 and the binomial tree will be constructed by more than two possible events in one day. This diagram can be shown in Figure 6 below:



**Figure 6:** Frequency of stock price process in one day ( $N=5$ )

The tree has many possible closing prices at each day which makes it more flexible and consistent with the real price changes, so the trading strategy will be chosen more accurately once the closing price is known.

For sigma parameter, we introduce the historical volatility (obtained from the regression) and implied volatility into the CRR model for comparison purposes. The following table illustrates the empirical evidence when we employ the CRR model with each different sigma to construct the binomial tree for 20 trading days.

**Table 3: Statistical data of the CRR model**

	Historical Vol	Implied Vol
$\sigma$	0.0352	0.0215
U	1.0158	1.0096
D	0.9844	0.9905
<i>for 20 trading days (100 periods)</i>		
initial stock price	stock will go up to	
100	481.7566	261.0392

Equation (3) is employed to estimate the historical volatility by using simple regression method (the detail is given in Chapter IV). When exploit the CRR model to our historical data during August to November 2008, the prices increase from 100 to 481.76 if the stock price keeps going up for the next 100 periods. For comparison, the implied volatility of SET50 index is used for representing  $\sigma$  over the same sample period. However, since this study investigates the pricing of option within 1-month maturity, we collect the implied volatility of SET50 index over September 2008 period (with maturity less than 1 month). The results show that SET50 index increases from 100 to 261.04 when the index keeps going up for the next 100 periods. The percentage change is approximately 161.04 %. As a result, in this study, the implied volatility will be employed to construct the binomial tree since it provides a more realistic price process than the historical volatility and it is widely used in practice.

##### 5. Optimal discrete option hedging strategies

This section derives optimal discrete time hedging strategies for replicating an option. This differs from the strategies of Cetin, Jarrow, Protter and Warachka (2006) in that we add the transaction cost into the dynamic programming.

A replication is often invoked in the incomplete markets literature due to its independence from investor preferences and probability beliefs. The portfolio value ( $Z$ ) equals the amount of money in the bank account plus the value of stock holding. In particular, let  $Z_t = X_t S(t, 0) + Y_t$  denote the time  $t$  marked-to-market value of the replicating portfolio where  $X_t$  represents the trader's aggregate holding of stock at time  $t$  and  $Y_t$  is the aggregate position in the money market account at time  $t$ . To find the least-

cost of a replicating portfolio, which will represent the option price, the following optimization problem is solved:

$$\min_{(x,y)} Z_0$$

subject to

$$Z_T \geq C_T = \max\{S(T,0) - Ke^{-rT}, 0\} \quad (7)$$

$$Z_T = y_0 + x_0 S(0,0) + \sum_{j=0}^{N-1} x_{\tau_{j+1}} [S(\tau_{j+1},0) - S(\tau_j,0)] - L_T - R_T \quad (8)$$

where  $x_0$  is the initial stock holding at the beginning of trade,  $y_0$  represents initial position in the money market account,  $S(0,0)$  represents an initial stock price, and  $C_T$  denotes the option payoff at time  $T$ , normalized by the value of the money market account, with a strike price  $K$  and maturity  $T$ .

The dynamic programming technique is used to solve for the optimal replicating portfolio value. This is done by starting from the last day and going backward one day at a time until we reach the first day. In particular, at time  $t$ , we solve for the following minimization problem

$$\min_{(x_j, y_j)} Z_t^j$$

subject to

$$y_j + x_j S_j U \geq \alpha [x_j^U - x_j]^2 S_j U + \theta |x_j^U - x_j| S_j U + \max(S_j U - K, 0) I(t) \quad (9)$$

$$y_j + x_j S_j D \geq \alpha [x_j^D - x_j]^2 S_j D + \theta |x_j^D - x_j| S_j D + \max(S_j D - K, 0) I(t) \quad (10)$$

where  $I(t) = 0$  if  $t < T-1$  and  $I(t) = 1$  if  $t = T-1$ .  $Z_t^j$  is the portfolio value at time  $t$  at node  $j$ ,  $y_j$  is the money market account, and  $x_j$  is the number of stock holding at time  $t$  after rebalancing at node  $j$ . The condition in inequality (9) states that the value of the portfolio at time  $t+1$  when the stock goes up must be no less than the cost of rebalancing the portfolio to the target holding  $x_j^U$  plus the option obligation if  $t+1$  is the expiration date. Similarly, condition in inequality (10) is for the case when the stock goes down.

For instance, consider a problem with term to maturity equal to three days (see Figure 7 and 8 below). At the maturity date (time 3), all shares will be liquidated to obtain the cash value of the portfolio on the last day of trade. As a result, the problem will begin at time 2 and then is solved backward to time 1 and time 0, respectively. Since we will consider only a short trading horizon, we will assume that  $r = 0$ . The minimization problem in each stage will be described as follows:

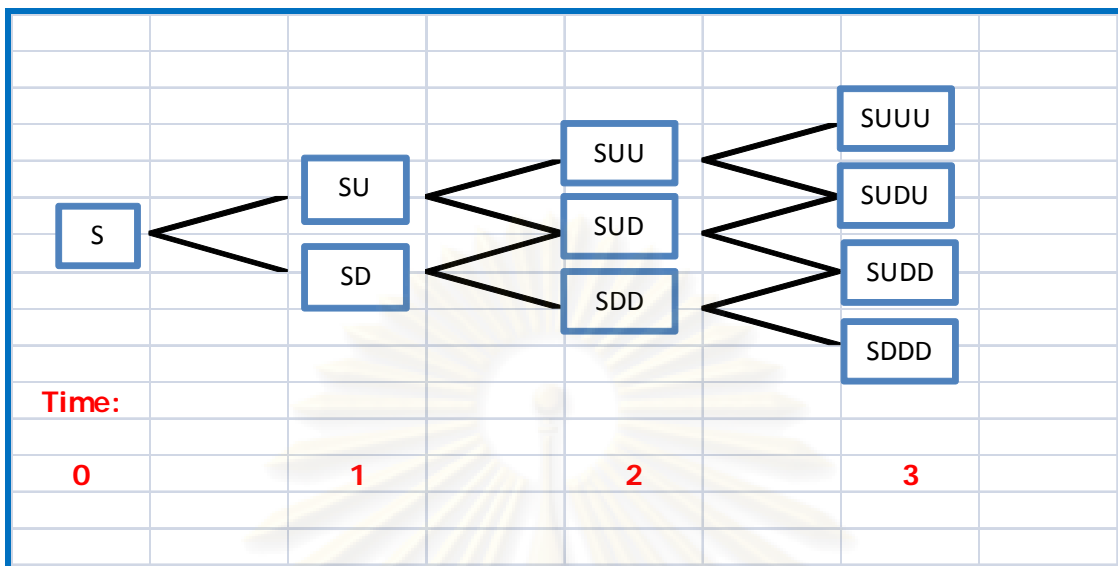


Figure 7: The binomial tree diagram of stock price process

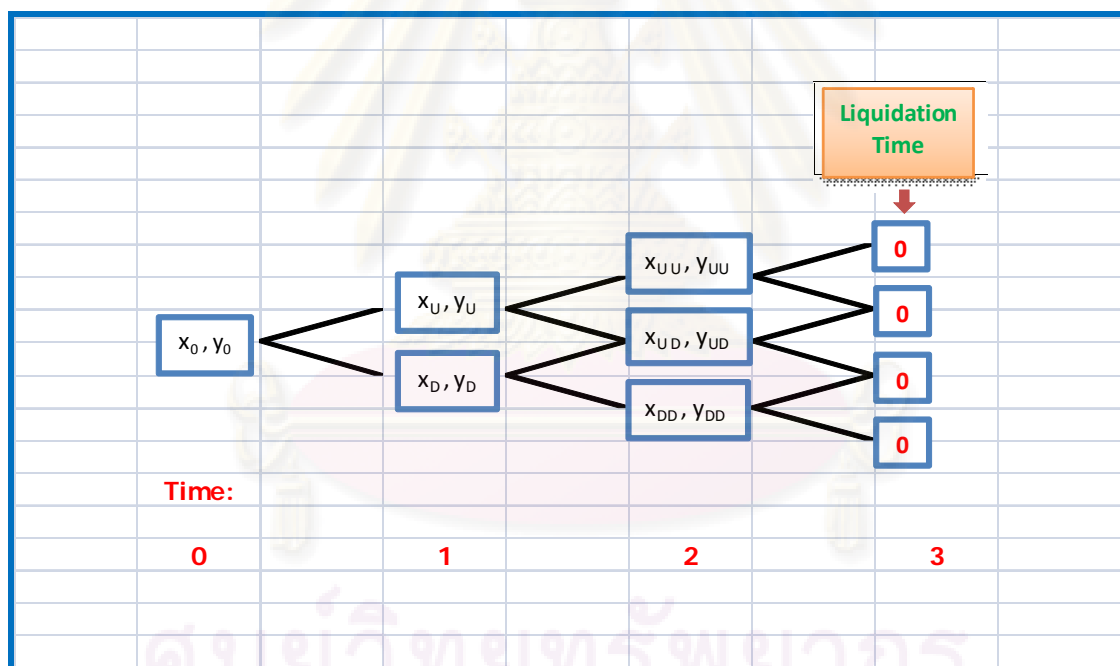


Figure 8: The number of stock holding and money account in each scenario

At time 2

- In the up state (UU) at the time before maturity (time 2), our objective is to solve for  $y_{UU}$  and  $x_{UU}$ . The stocks holding will then be liquidated at the end (time 3). The following minimization problem is solved for  $y_{UU}$  and  $x_{UU}$  by

$$\min Z_2^{UU} = y_{UU} + x_{UU}SUU \quad (11)$$

subject to

$$y_{UU} + x_{UU}SUUU \geq \max(SUUU - K, 0) + \alpha[0 - x_{UU}]^2 SUUU + \theta|0 - x_{UU}|SUUU$$

$$y_{UU} + x_{UU}SUUD \geq \max(SUUD - K, 0) + \alpha[0 - x_{UU}]^2 SUUD + \theta|0 - x_{UU}|SUUD$$

where  $y_{UU}$  represents the amount of money in the bank account before maturity and  $x_{UU}$  is the number of stock holding before liquidating at maturity.  $SUUU$  is the stock price after the stock keeps going up for 3 periods. To find the least cost of replicating portfolio, the objective function is to minimize the portfolio value subject to those constraints. Each of the equations above is one of the two possible stock price paths from time 2 to time 3. In particular, the left side displays the portfolio value after the change in stock price, while the right side is the option payoff at either the up or down node plus the associated liquidity and transaction cost for liquidating the portfolio at time 3.

- In the up-down node (UD), the following minimization problem is solved for  $y_{UD}$  and  $x_{UD}$

$$\min Z_2^{UD} = y_{UD} + x_{UD}SUD \quad (12)$$

subject to

$$y_{UD} + x_{UD}SUUD \geq \max(SUUD - K, 0) + \alpha[0 - x_{UD}]^2 SUUD + \theta|0 - x_{UD}|SUUD$$

$$y_{UD} + x_{UD}SUDD \geq \max(SUDD - K, 0) + \alpha[0 - x_{UD}]^2 SUDD + \theta|0 - x_{UD}|SUDD$$

where  $y_{UD}$  represents the amount of money in the bank account before maturity and  $x_{UD}$  is the number of stock holding before liquidating at maturity. The  $SUDU$  is the stock price which goes up, down and up in period 1 to period 3, respectively. While  $SUDD$  is the price of stock after the stock goes up in the first period and then goes down in the next 2 periods.

- In the down node (DD), the following minimization problem is solved for  $y_{DD}$  and  $x_{DD}$

$$\min Z_2^{DD} = y_{DD} + x_{DD}SDD \quad (13)$$

subject to

$$y_{DD} + x_{DD}SUDD \geq \max(SUDD - K, 0) + \alpha[0 - x_{DD}]^2 SUDD + \theta|0 - x_{DD}|SUDD$$

$$y_{DD} + x_{DD}SDDD \geq \max(SDDD - K, 0) + \alpha[0 - x_{DD}]^2 SDDD + \theta|0 - x_{DD}|SDDD$$



where  $y_{DD}$  represents the amount of money in the bank account before maturity and  $x_{DD}$  is the number of stock holding before liquidating at maturity.  $S_{DD}$  is the stock price after the stock goes down for 3 periods.

At time 1

- In the up state (U), the following minimization problem is solved for  $y_U$  and  $x_U$ .

$$\min Z_1^U = y_U + x_U S_U \quad (14)$$

subject to

$$y_U + x_U S_{UU} \geq \alpha [x_{UU} - x_U]^2 S_{UU} + \theta |x_{UU} - x_U| S_{UU}$$

$$y_U + x_U S_{UD} \geq \alpha [x_{UD} - x_U]^2 S_{UD} + \theta |x_{UD} - x_U| S_{UD}$$

where  $y_U$  represents the amount of money in the bank account in the up stage at time 1 and  $x_U$  is the number of stock holding in the up stage at time 1.  $x_{UU}$  and  $x_{UD}$  is the optimal number of stock holding in the UU and UD stages, respectively, obtained from the previous steps.  $S_{UU}$  is the price of stock after the stock keeps going up for 2 periods and  $S_{UD}$  is the stock price after the stock goes up in the first period and then goes down in the period after.

- Similarly, in the down node (D), the quantities  $y_D$  and  $x_D$  are obtained as the solution to this following minimization problem

$$\min Z_1^D = y_D + x_D S_D$$

subject to

$$y_D + x_D S_{UD} \geq \alpha [x_{UD} - x_D]^2 S_{UD} + \theta |x_{UD} - x_D| S_{UD} \quad (15)$$

$$y_D + x_D S_{DD} \geq \alpha [x_{DD} - x_D]^2 S_{DD} + \theta |x_{DD} - x_D| S_{DD}$$

where  $y_D$  represents the amount of money in the bank account in the down stage at time 1 and  $x_D$  is the number of stock holding in the down stage at time 1, and  $S_{DD}$  is the stock price after the stock keeps going down for 2 periods.

At time 0

- At time 0, the minimization problem is

$$\min Z_0 = x_0 S + y_0 + \alpha x_0^2 S + \theta |x_0| S$$

subject to

$$\begin{aligned}
 y_0 + x_0(SU) &\geq y_U + x_U SU + \alpha[x_U - x_0]^2 SU + \theta|x_U - x_0|SU \\
 y_0 + x_0(SD) &\geq y_D + x_D SD + \alpha[x_D - x_0]^2 SD + \theta|x_D - x_0|SD
 \end{aligned}
 \tag{16}$$

where  $y_0$  represents the initial amount of money in the bank account and  $x_0$  is the initial number of stock holding. From the optimal  $x_0$  and  $y_0$  values, the price of the call option equals  $x_0 S + y_0 + \alpha(x_0)^2 S + \theta|x_0|S$ , which consists of the value of the initial portfolio ( $x_0 S + y_0$ ) and the liquidity and transaction costs of constructing the initial portfolio ( $\alpha(x_0)^2 S + \theta|x_0|S$ ).



ศูนย์วิทยทรัพยากร  
จุฬาลงกรณ์มหาวิทยาลัย

## CHAPTER IV RESULTS

### A. Empirical Results

#### 1. Liquidity parameter

To estimate the liquidity parameter ( $\alpha$ ), a simple regression methodology is employed by using the equation (3). A series of TDEX tick data including prices, trading volumes and time of trading transactions is used for daily estimation of  $\alpha$  and  $\mu$ . We use the data from August 2008 to November 2008 with a total of 21,354 samples over the 84 trading days. Table 4 summarizes the regression results.

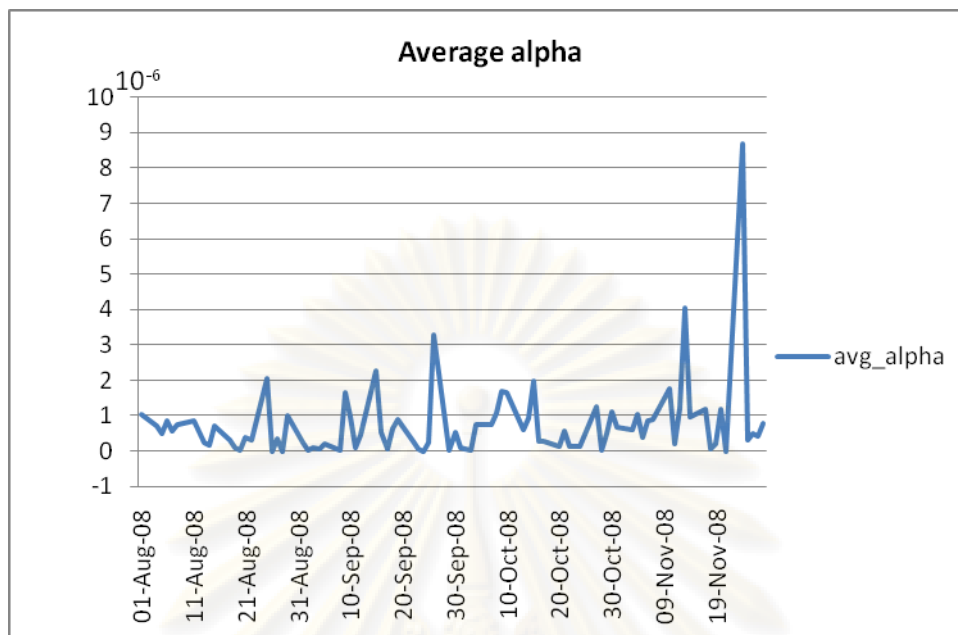
*Table 4: Summary statistics of alpha and mu*

	Average	Median	Minimum	Maximum	1% Level (Days)	5% Level (Days)
$\alpha \times 10^{-7}$	7.5417	4.9850	-0.2700	86.9000	54	59
$\mu$	0.0365	0.0334	-0.6350	1.3478	0	5

\* Total of 84 days in sample

The estimated daily  $\alpha$ 's are positively statistically significant at the 5% level for 59 days out of 84 days while  $\mu$ 's are significantly different from 0 for only 5 days. The positivity of  $\alpha$  assures that the supply curve is upward sloping.

The plot of daily estimated  $\alpha$ 's during the sample period is shown in Figure 9. The average of these  $\alpha$ 's equals  $7.5417 \times 10^{-7}$  which will be used as the liquidity parameter in the dynamic programming of the subsequent studies. The average of estimated  $\alpha$ 's implies that if the net stock position is changed by 100 shares, the log return will change by  $7.5417 \times 10^{-5}$  when holding other parameters constant.

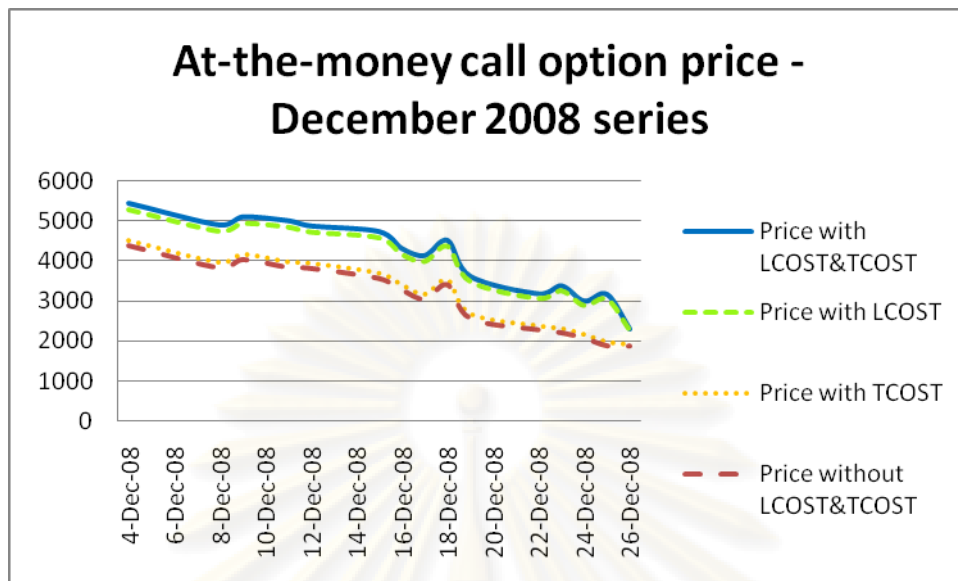


**Figure 9:** Plot of estimated alpha parameter

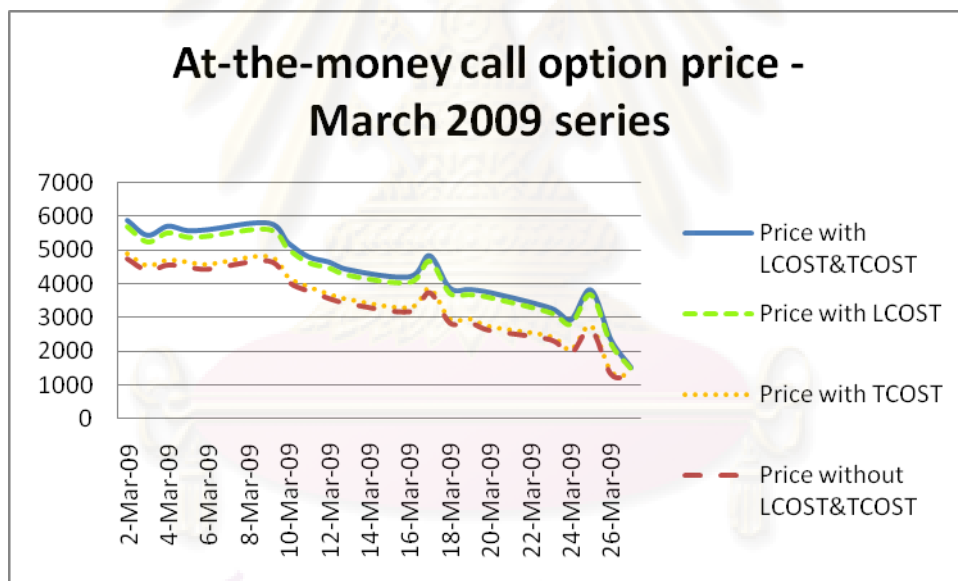
## 2. Call option prices

To investigate the impact of liquidity and transaction costs on the option prices, our study introduces the four different specifications on option valuation: pricing option without liquidity and transaction costs, pricing option with only liquidity cost, pricing option with only transaction cost and pricing option with both liquidity and transaction costs. These options are European call options maturing in December 2008, March 2009 and June 2009 with various moneyness; at-the-money, in-the-money and out-of-the-money. The option prices are illustrated in the figures below.

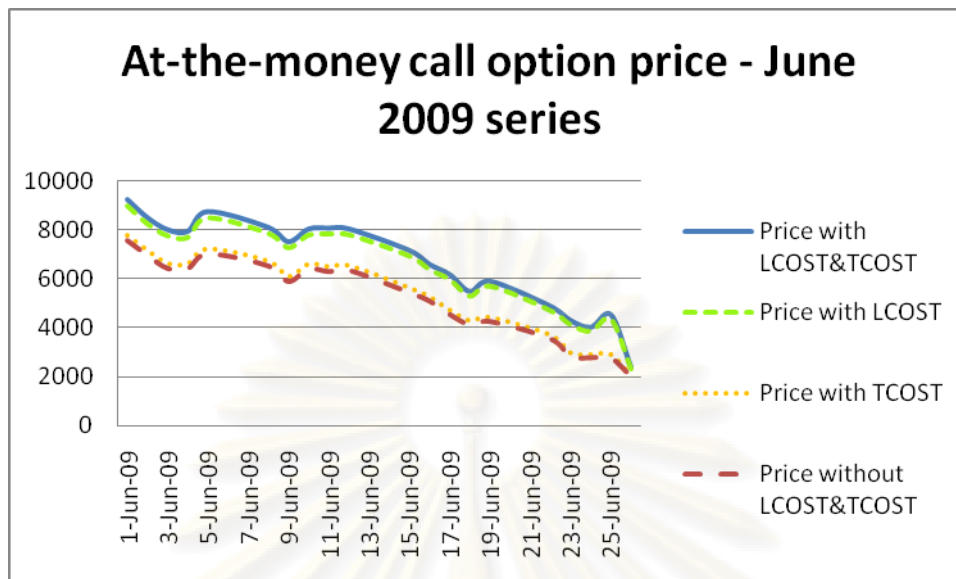
ศูนย์วิทยทรัพยากร  
จุฬาลงกรณ์มหาวิทยาลัย



**Figure 10:** Comparing at-the-money call option prices in December series

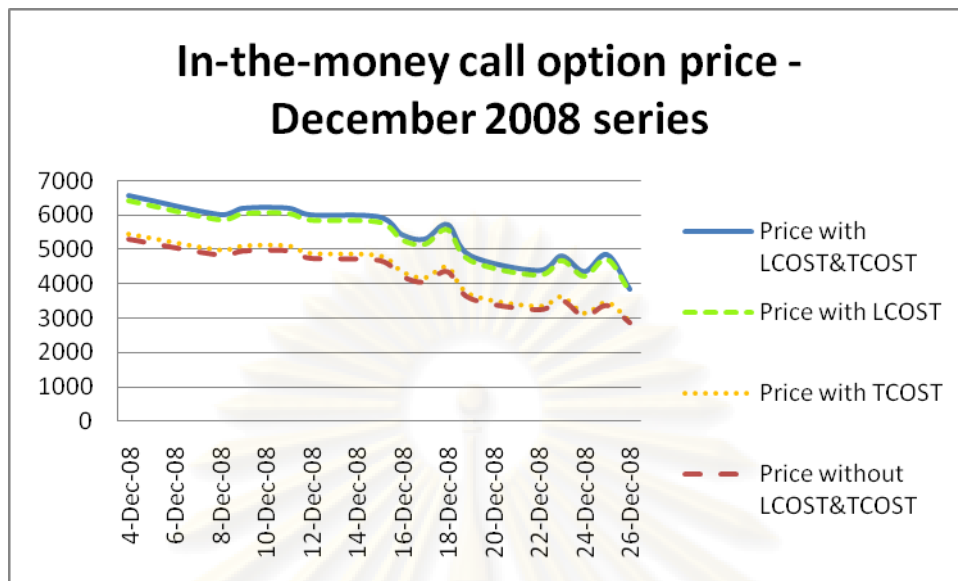


**Figure 11:** Comparing at-the-money call option prices in March series

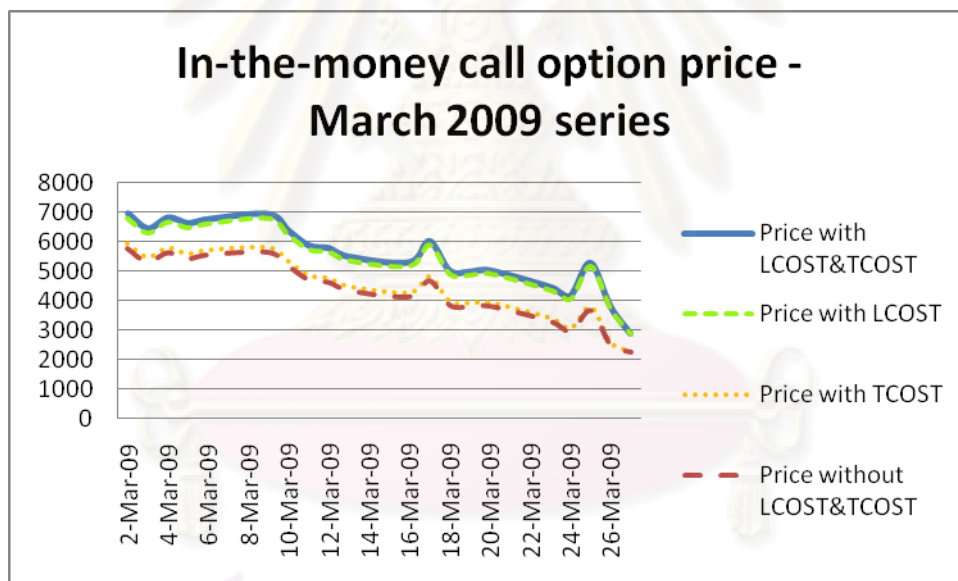


**Figure 12:** Comparing at-the-money call option prices in June series

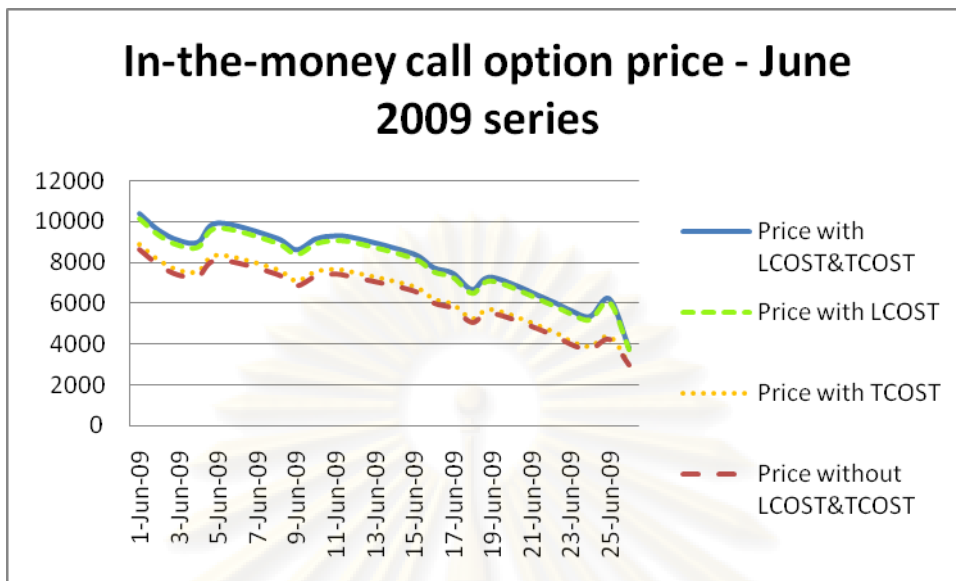
For at-the-money call option, as expected, the option prices with liquidity and transaction costs are highest while the option prices with no liquidity and transaction costs are lowest. The prices with liquidity cost move along with the price with liquidity and transaction costs whereas prices with transaction cost move along with the prices without liquidity and transaction costs. As we can see, the liquidity cost component is much larger than the transaction cost component. When time approaches maturity, the trading activity in the replicating portfolio is expected to be low, and hence the liquidity and transaction cost components become smaller.



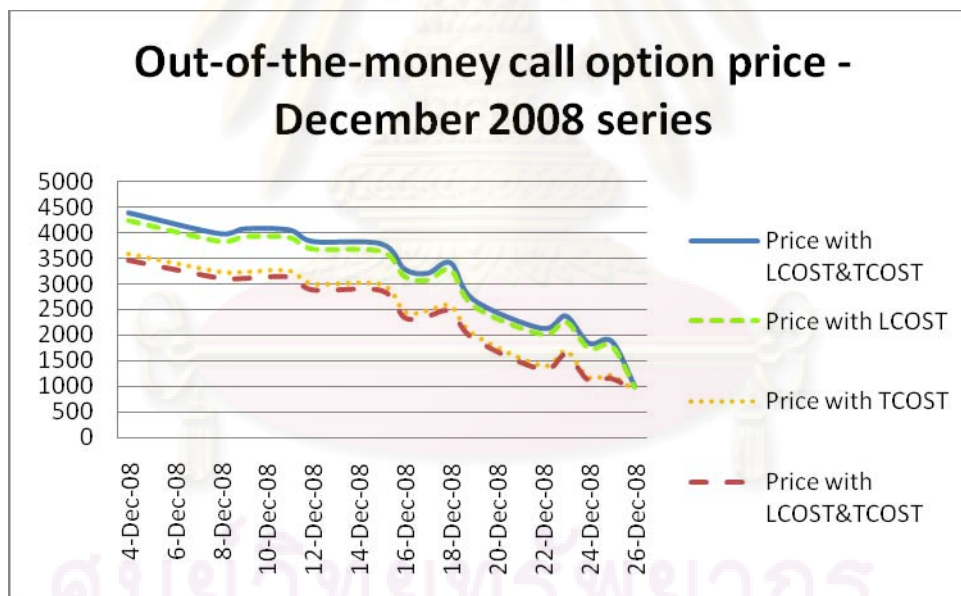
**Figure 13:** Comparing in-the-money call option prices in December series



**Figure 14:** Comparing in-the-money call option prices in March series



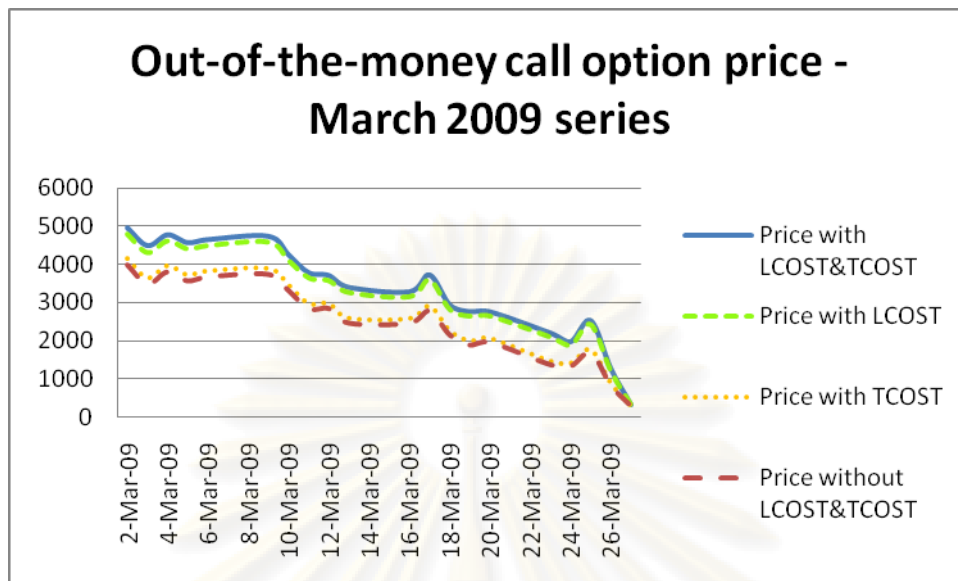
*Figure 15: Comparing in-the-money call option prices in June series*



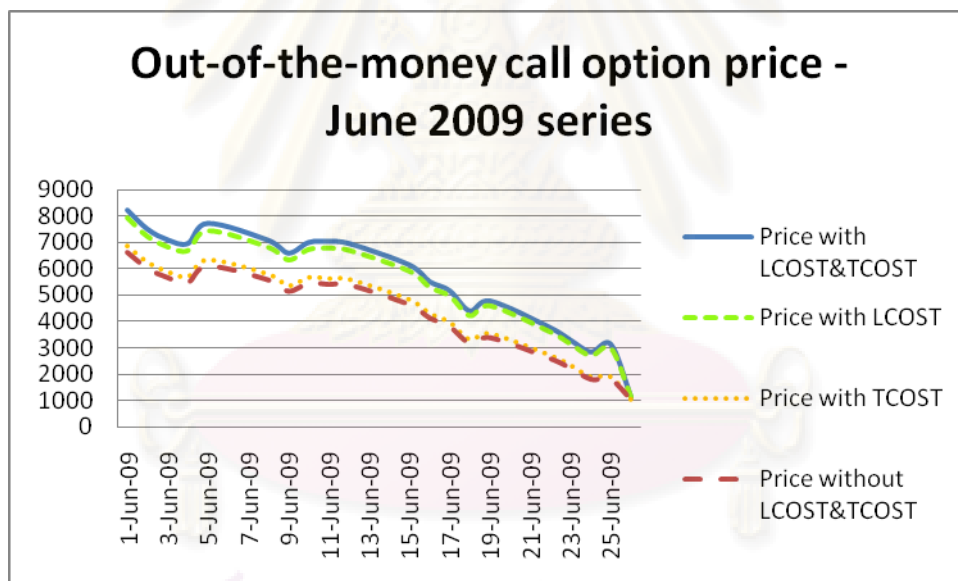
*Figure 16: Comparing out-of-the-money call option prices in December series*

จุฬาลงกรณ์มหาวิทยาลัย





**Figure 17:** Comparing out-of-the-money call option prices in March series



**Figure 18:** Comparing out-of-the-money call option prices in June series

The results are the same for in-the-money and out-of-the-money call options of December, March and June series. Note, however, that the values of the out-of-the-money options under the four specifications become almost the same when the time to maturity approaches zero.

Table 5 below illustrates the impact of the cost components as a percentage of the option price when there are no liquidity and transaction costs. Observe that the transaction cost component increases the option price by approximately only 3-5% while the liquidity

cost component increases the option price by approximately 25-33%. Moreover, we can see that the sum of the impact from the transaction cost and the impact from the liquidity cost is less than the total impact when both transaction and liquidity costs are present.

**Table 5: Summary of percentage change in prices**

		CRR Model (%)		
		December	March	June
<b>In-the-money</b>	<i>Price(TCOST)</i>	3.3916	3.3473	3.3751
	<i>Price(LCOST)</i>	27.9754	25.9194	25.3607
	<i>Price(LCOST&amp;TCOST)</i>	31.5220	29.3946	28.8741
<b>At-the-money</b>	<i>Price(TCOST)</i>	4.2467	4.1404	3.9474
	<i>Price(LCOST)</i>	31.4494	28.5320	27.8235
	<i>Price(LCOST&amp;TCOST)</i>	36.0250	32.9163	32.0100
<b>Out-of-the-money</b>	<i>Price(TCOST)</i>	5.0147	4.4223	4.4027
	<i>Price(LCOST)</i>	32.7514	26.4303	28.7420
	<i>Price(LCOST&amp;TCOST)</i>	38.3442	31.2518	33.5143

ศูนย์วิทยพัทยากร  
จุฬาลงกรณ์มหาวิทยาลัย

## CHAPTER V

### ARBITRAGE TRADING STRATEGY

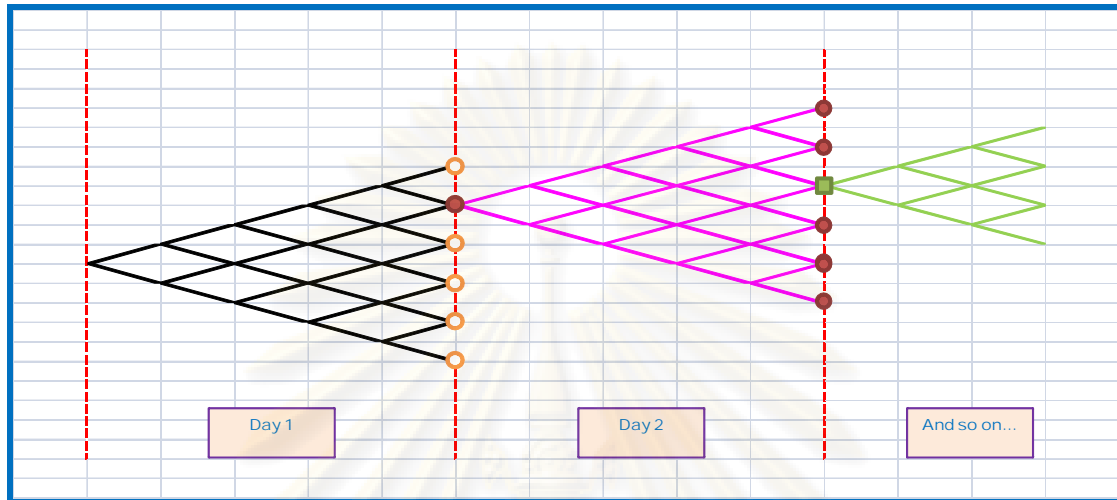
#### A. Strategy

This chapter provides an example of an arbitrage trading strategy in the real trading process by applying the dynamic programming. A portfolio of both stock and money market account will be constructed to replicate the call option payoff. The idea is to determine whether it is possible to construct the portfolio which has terminal value (after deducting all liquidity and transaction costs) higher than the payoff of the options with a cost lower than the option price. If the answer is YES, it is likely that there might be an arbitrage opportunity obtained by issuing a call option and then using the obtained option premium to construct a portfolio which finally generates higher terminal value (covering the payback of the options).

Generally, people decide to trade if the terminal value of the portfolio is higher than the option payoff because they can earn the profit. But if the terminal value of the portfolio is less than payoff of the options, they will short stock and long the option instead.

The trading strategy of shorting options and buying stocks will be introduced to examine an arbitrage opportunity when the option price from the model is less than the market option price. In each day, the portfolio will be rebalanced only at the end of the day by matching the market closing price of the stock to the stock price from the binomial tree. From the model, each node of the binomial tree is associated with different price and different number of stock needed to hold. By matching the model price from the tree with the market price of the underlying asset, the number of stock holding is known. However, if the market price of stock falls between any two nodes of the tree, the closest node will be chosen. Then the number of stock to be traded will be known. If the anticipated number of stock holding is greater than the stock holding from the last day, we have to long more stock and need more money. Thus money market account ( $y$ ) will decrease. On the other hand, if the anticipated amount of stock holding is less than the stock holding from the previous day, we have to short more stock and the money market account will increase. Moreover, we have to subtract the transaction costs of buying or selling the

stocks from the money market account to update their value in each trading day. In the next day, the same step will be exploited until the last trading day.

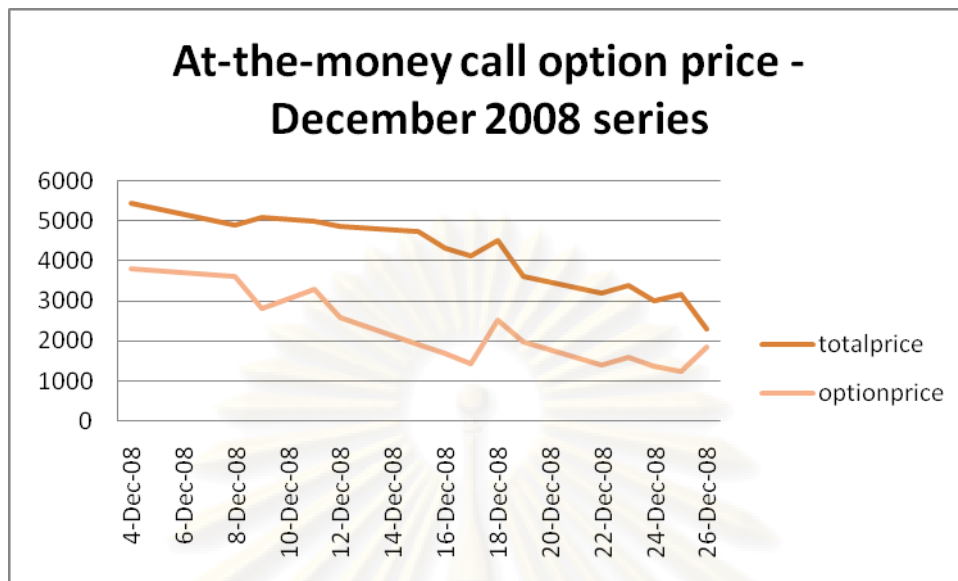


*Figure 19: The price matching in the multi-period binomial tree diagram*

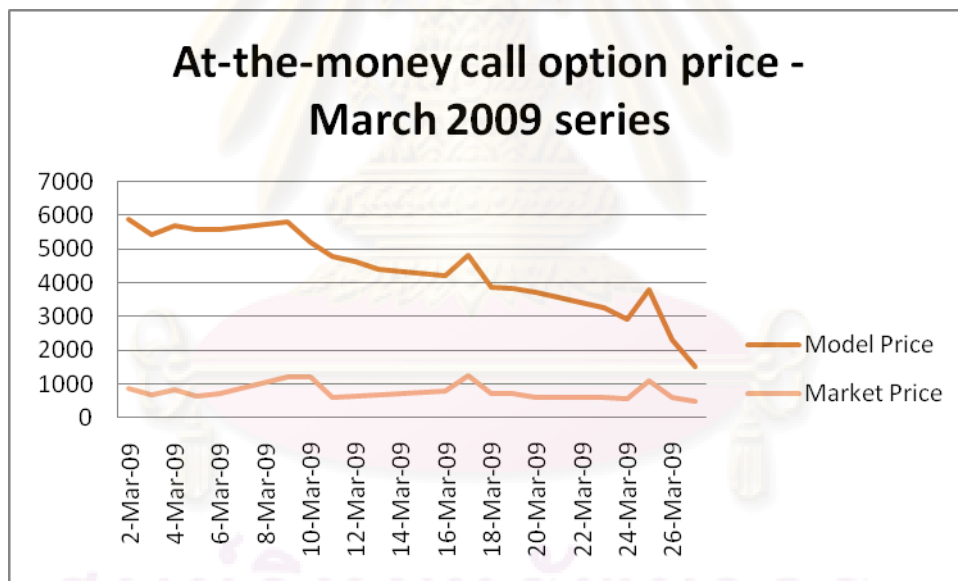
At the last day of trade, the amount of stock holding will be liquidated. Thus if the value of the liquidated portfolio is greater than the option payoff, this means that our arbitrage trading strategy succeeds. But if the value of the liquidated portfolio is less than the option payoff, this means that the trading strategy fails. The cost of trading the option will also be taken into account. Finally, we note that our methodology accounts for only liquidity and transaction costs and a discrete trading method in determining the arbitrage opportunities. However in real world, there might be other factors affecting option prices and consequently the profit generated from our trading strategy might not guarantee the existence of a real arbitrage opportunity. We leave this issue for the future research.

## **B. Model Prices VS. Market Prices**

The call option prices from the model with liquidity and transaction costs and the actual market option prices maturing in December 2008, March 2009 and June 2009 are shown in the figure below.

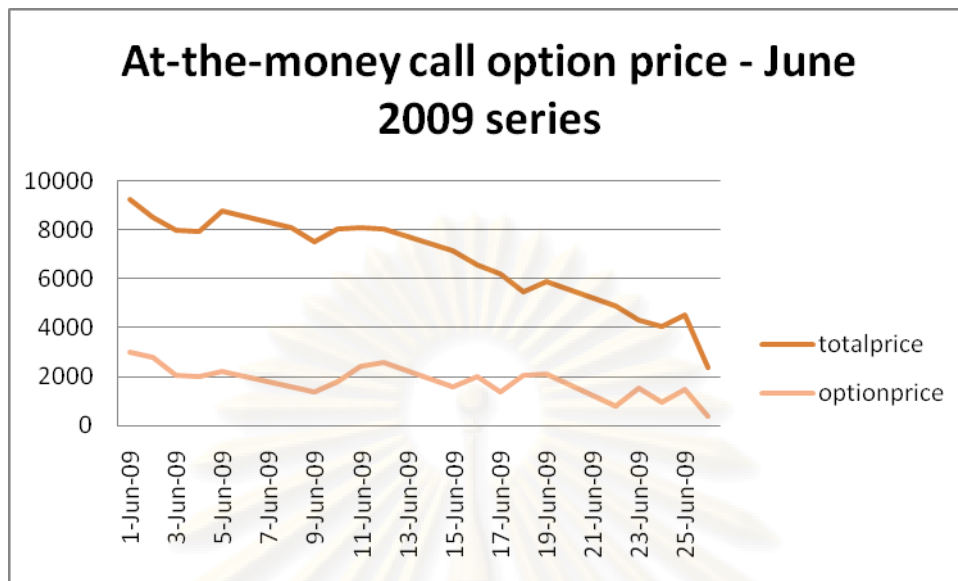


*Figure 20: Prices of at-the-money call option in December series*

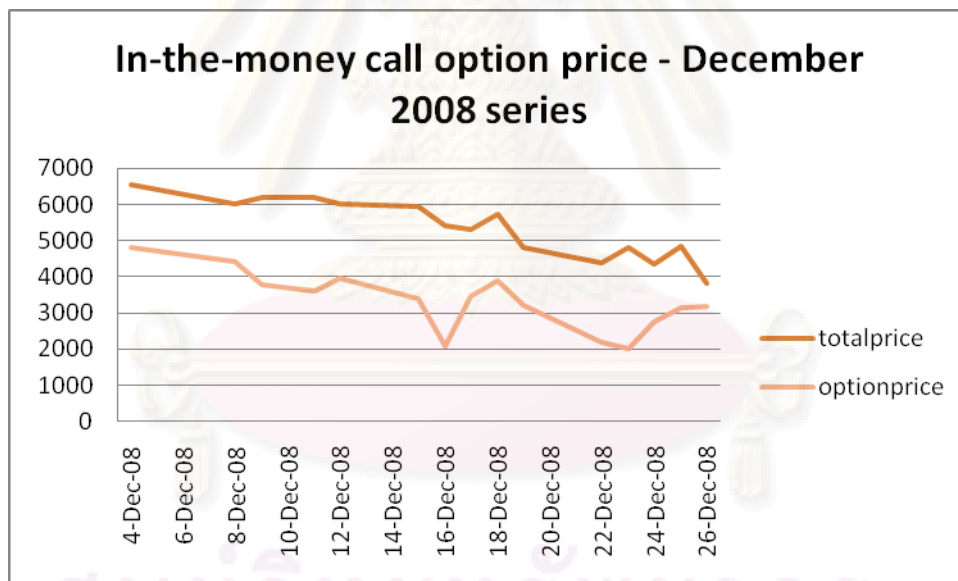


*Figure 21: Prices of at-the-money call option in March series*

จุฬาลงกรณ์มหาวิทยาลัย

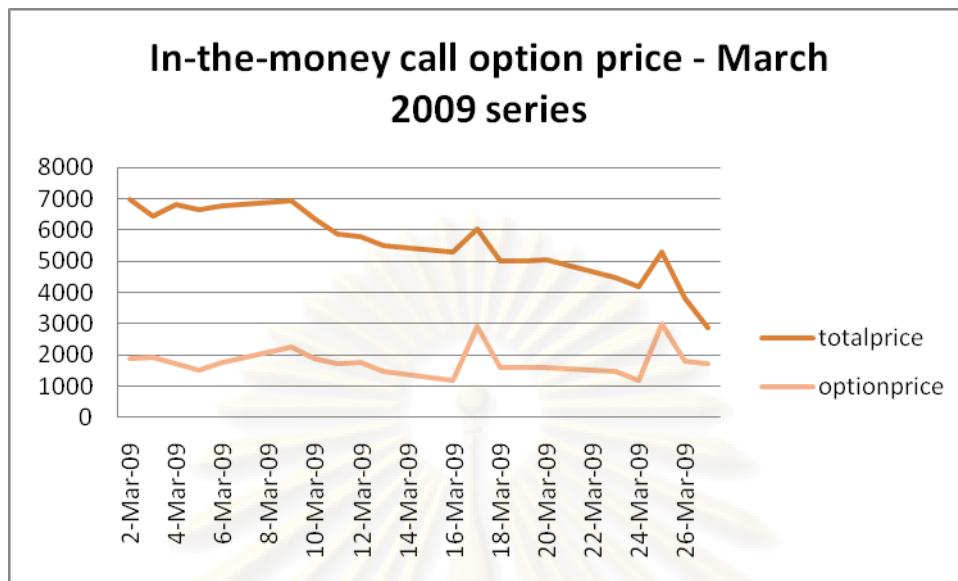


*Figure 22: Prices of at-the-money call option in June series*

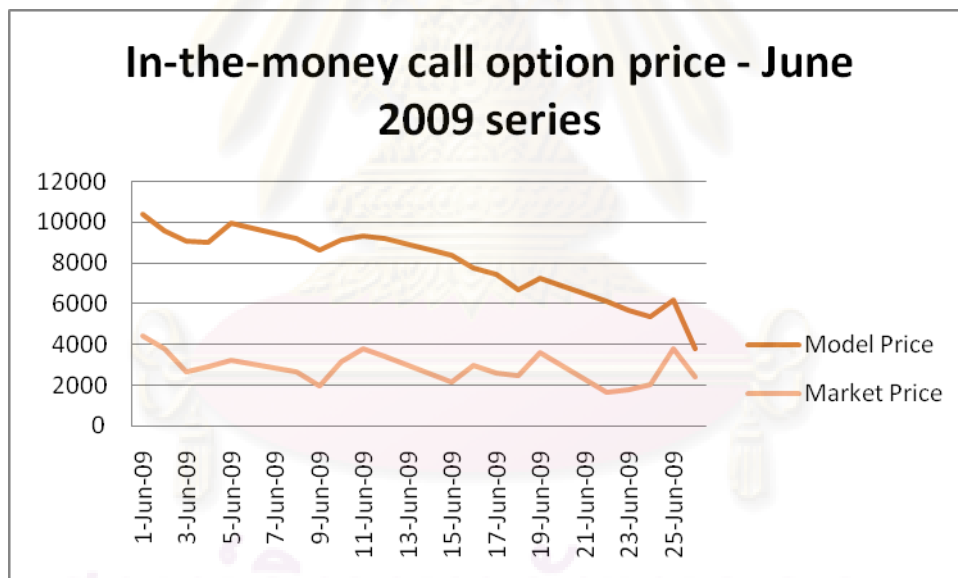


*Figure 23: Prices of in-the-money call option in December series*

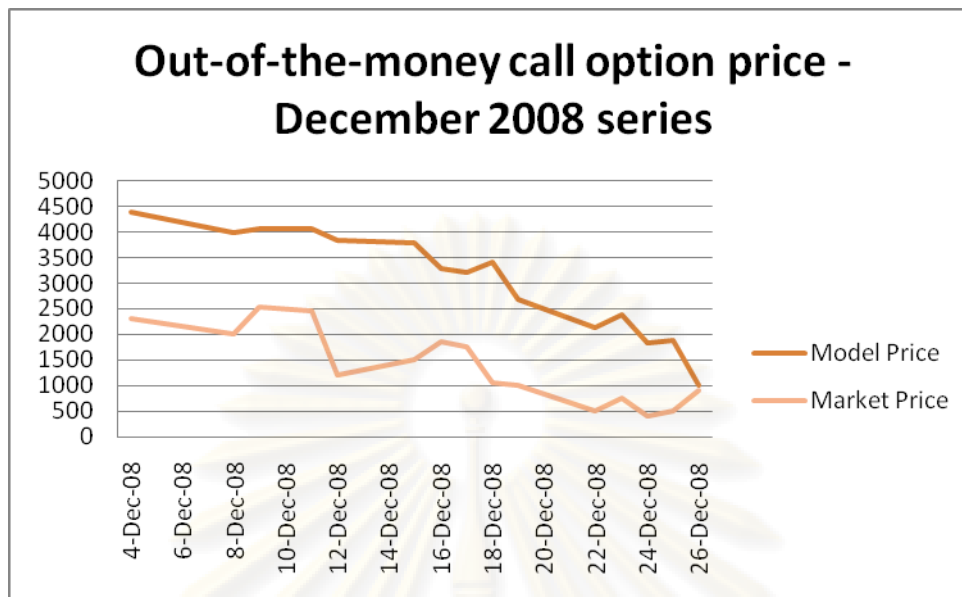
จุฬาลงกรณ์มหาวิทยาลัย



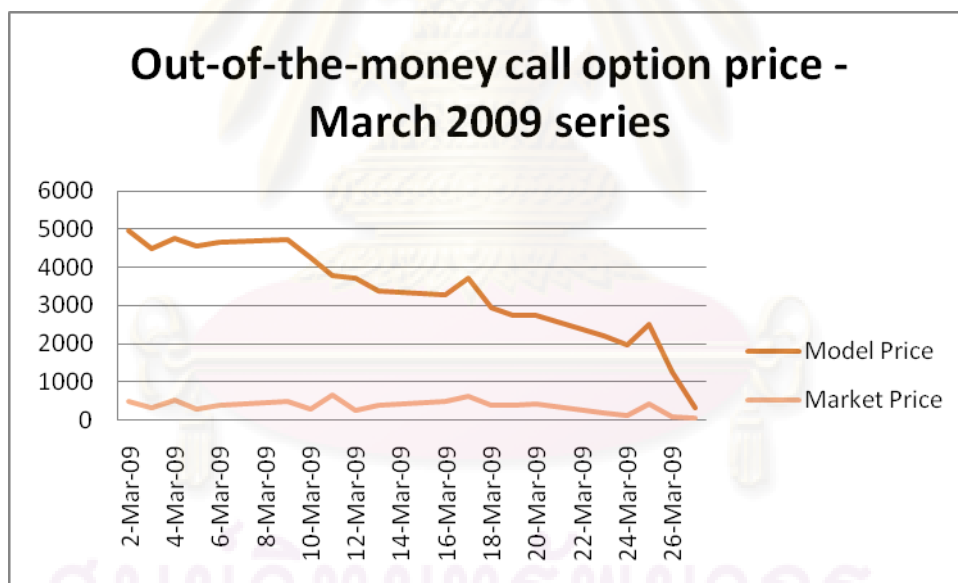
*Figure 24: Prices of in-the-money call option in March series*



*Figure 25: Prices of in-the-money call option in June series*



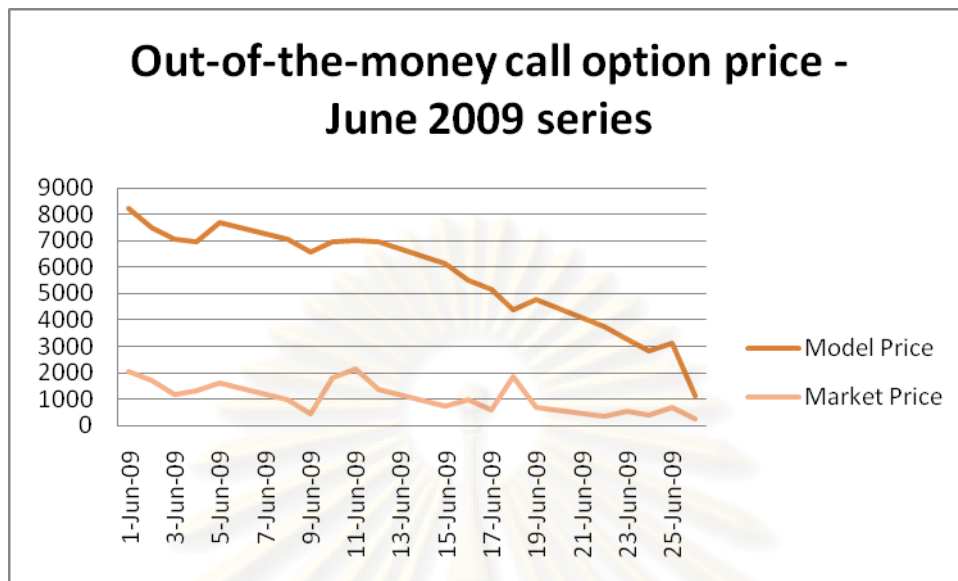
*Figure 26: Prices of out-of-the-money call option in December series*



*Figure 27: Prices of out-of-the-money call option in March series*

จุฬาลงกรณ์มหาวิทยาลัย





**Figure 28:** Prices of out-of-the-money call option in June series

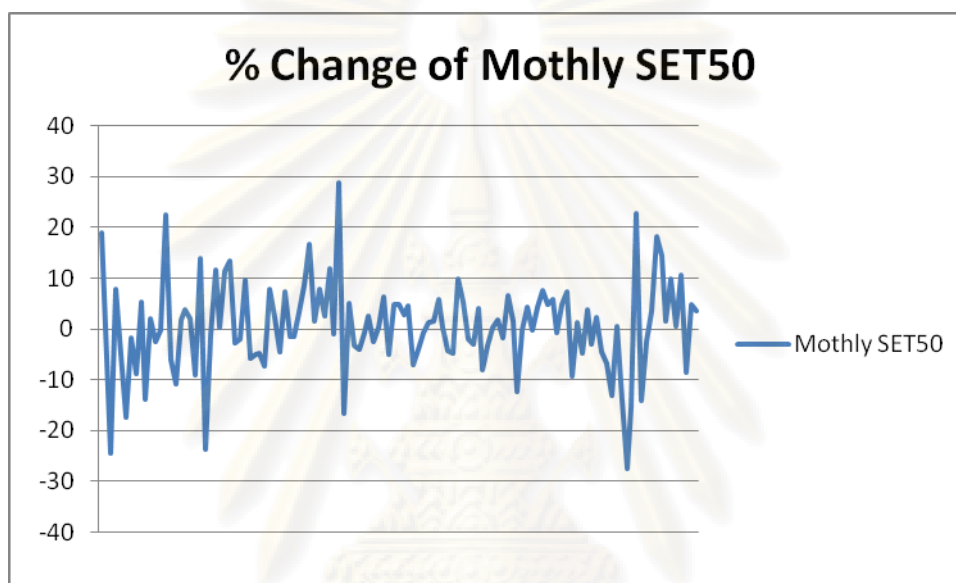
Each figure shows that the option fair prices obtained from the model are quite high. Specifically, the option prices obtained from this model with liquidity and transaction costs are always higher than the actual market prices of option. Consequently, it does not seem to present us with an arbitrage opportunity by using our proposed model with liquidity and transaction costs.

Hence, in order to demonstrate how one would exploit an arbitrage opportunity should it existed, we shall assume an arbitrary figure of 10% annual. This will enable us to explore a dynamic programming based trading methodology. However, from now on, we will demonstrate how to exploit the arbitrage opportunity if it existed assuming the annualized implied volatility to 10% per year. This new implied volatility will allow the call option price change approximately 31.96% in one month. This percentage price change is quite consistent with the historical price data of SET50 Index between 2000 and 2010 in which the index levels have changed with no more than 30% in any one-month period, even in the bad economic condition.

จุฬาลงกรณ์มหาวิทยาลัย

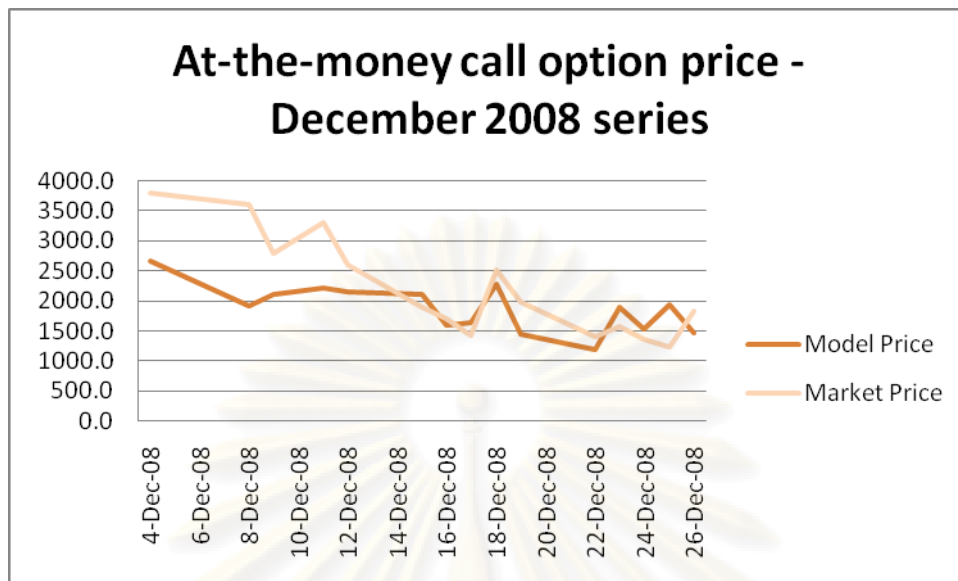
**Table 6:** Summary statistics of monthly returns of SET50

	Monthly-SET50
Average Value (in absolute)	13.9561
Maximum Value	28.7179
Minimum Value	-27.4000
Standard Deviation	9.0725

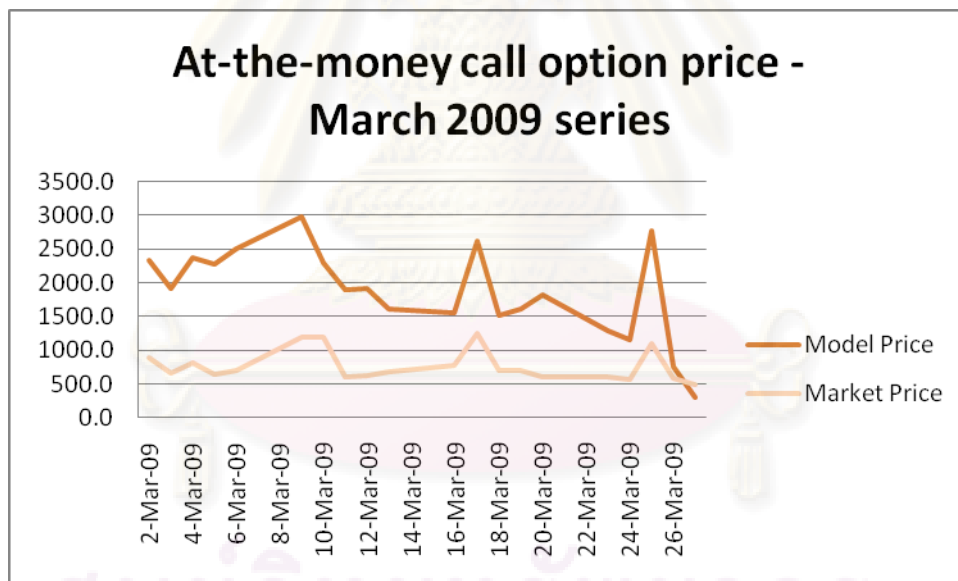
**Figure 29:** The percentage change of one-month SET50 index

With the 10% implied volatility, the call option prices in each maturity are presented as follow.

ศูนย์วิทยทรัพยากร  
จุฬาลงกรณ์มหาวิทยาลัย

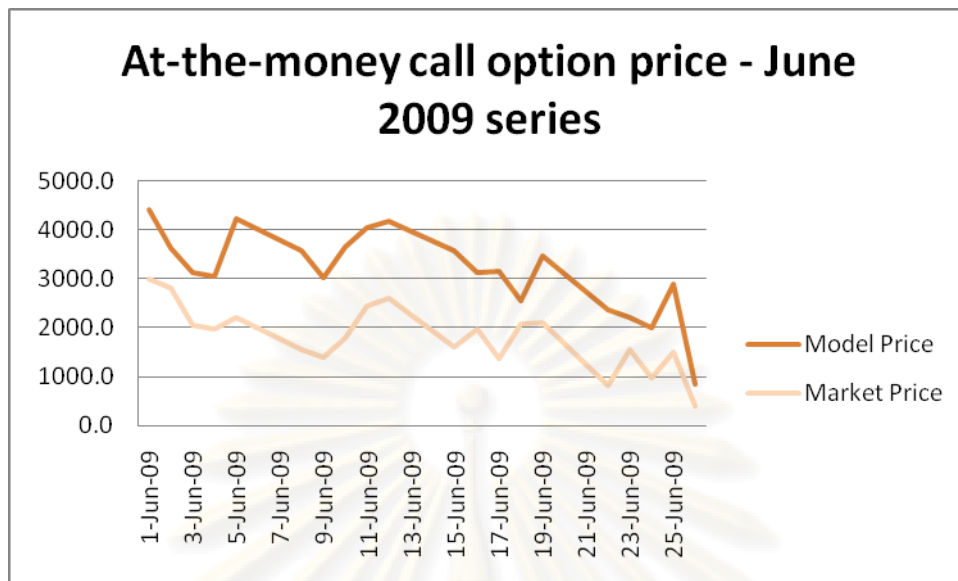


**Figure 30:** Prices of at-the-money call option in December series ( $\sigma=0.1$ )



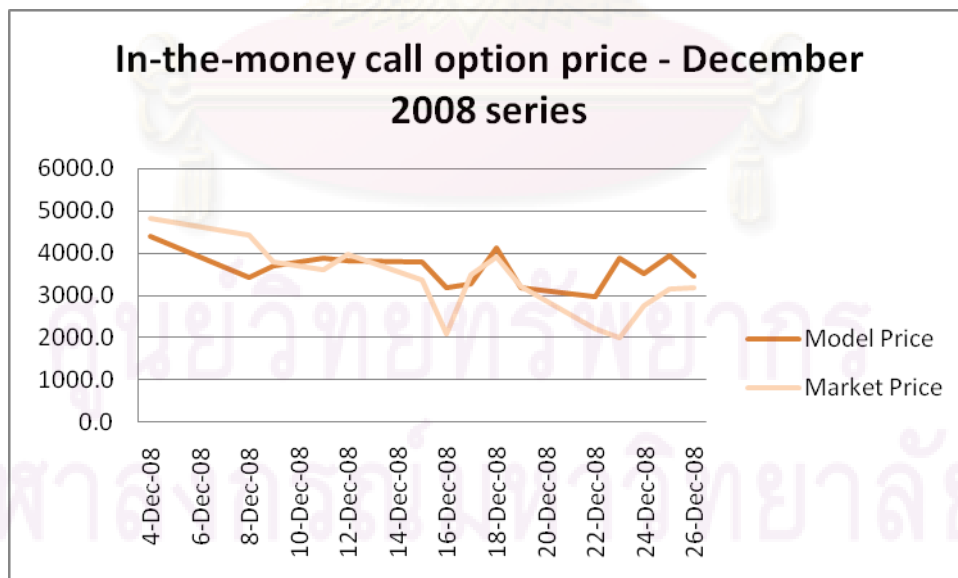
**Figure 31:** Prices of at-the-money call option in March series ( $\sigma=0.1$ )

จุฬาลงกรณ์มหาวิทยาลัย

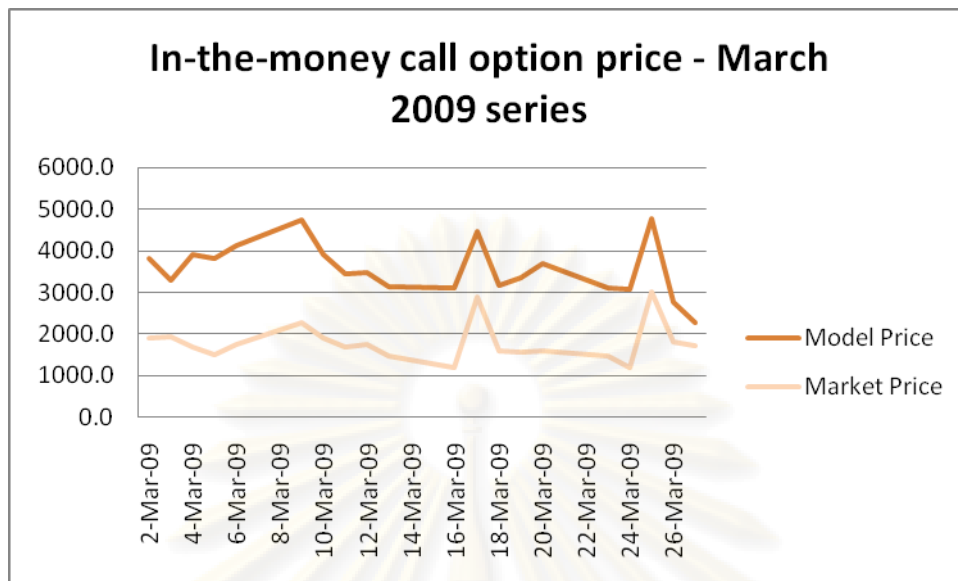


**Figure 32:** Prices of at-the-money call option in June series ( $\sigma=0.1$ )

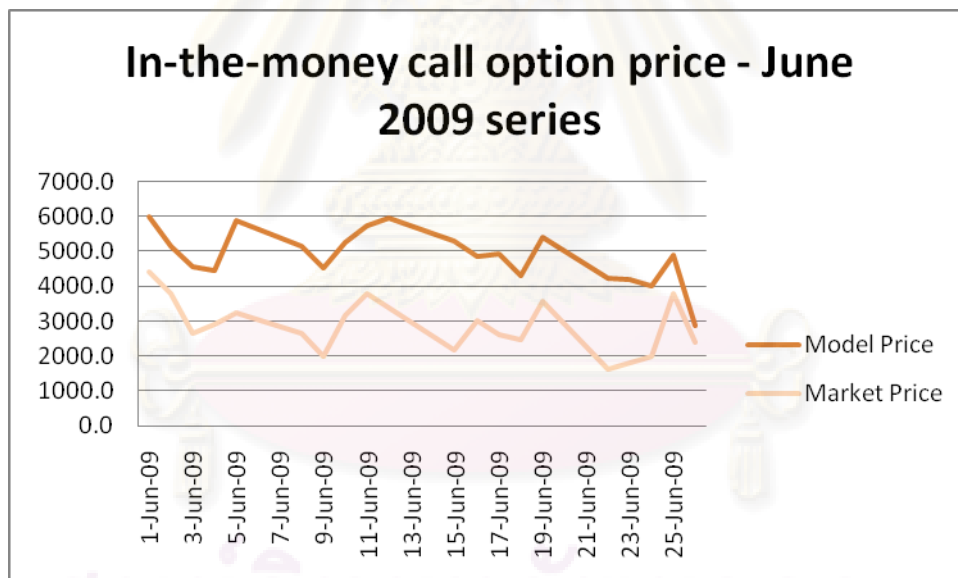
For at-the-money call option of December 2008 series, the prices from the model with liquidity and transaction costs are lower than the market prices in the first period and then they are fluctuated until maturity date. For the call option of March and June 2009 series, the model prices are generally higher than the market prices except for the last trading day in March series where the model price is lower than the market price.



**Figure 33:** Prices of in-the-money call option in December series ( $\sigma=0.1$ )

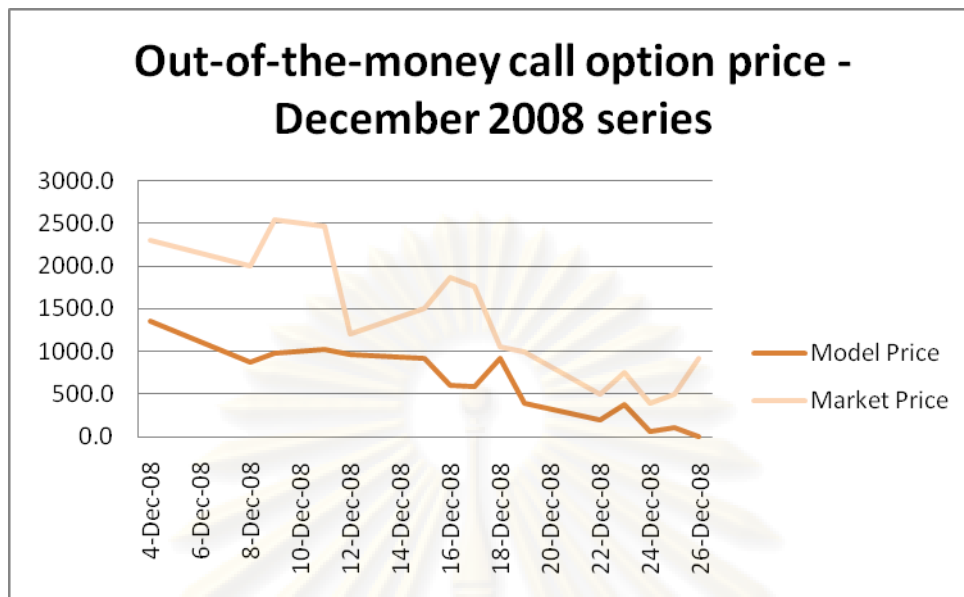


**Figure 34:** Prices of in-the-money call option in March series ( $\sigma=0.1$ )

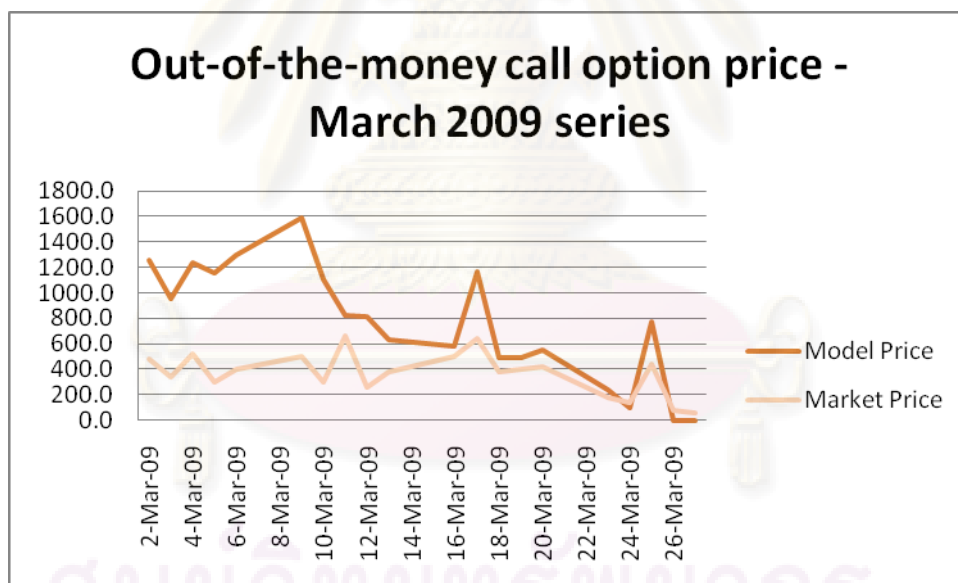


**Figure 35:** Prices of in-the-money call option in June series ( $\sigma=0.1$ )

For in-the-money call option of December 2008 series, the model prices are lower than the market prices in the first period and then they are quite higher than the market prices in some periods until maturity date. For the call option of March and June 2009 series, the model prices are higher than the market prices for these whole periods.

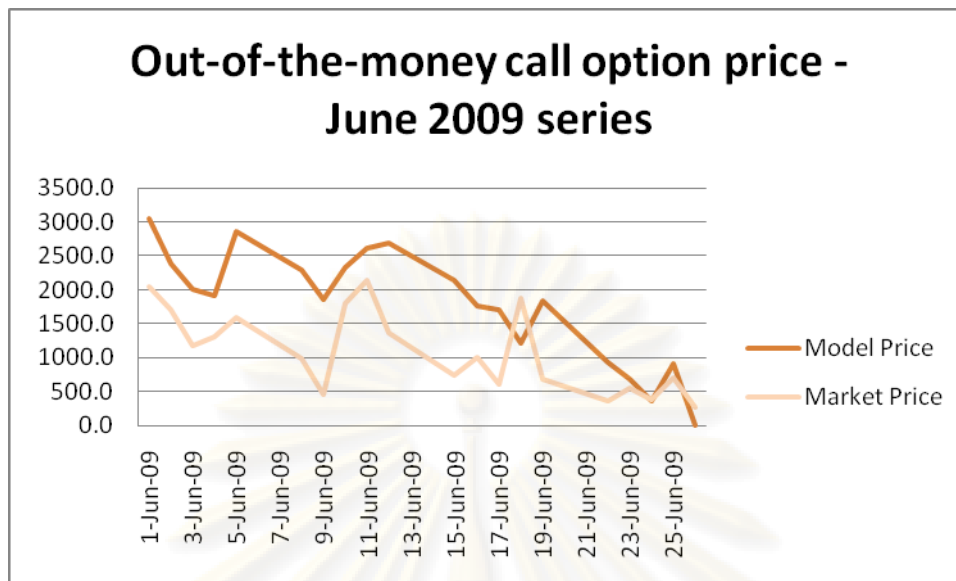


**Figure 36:** Prices of out-of-the-money call option in December series ( $\sigma=0.1$ )



**Figure 37:** Prices of out-of-the-money call option in March series ( $\sigma=0.1$ )

จุฬาลงกรณ์มหาวิทยาลัย



**Figure 38:** Prices of out-of-the-money call option in June series (sigma=0.1)

For out-of-the-money call option of December 2008 series, the model prices are lower than the market prices for the whole period. However, in March 2009 series, the model prices are higher than the market prices and then they are turned to be lower in the last period. In June 2009 series, the model prices are generally higher than the market prices more than the first-half of this month. Then they are fluctuated and turned to be lower in the last period.

In brief, these graphs illustrate that there are approximately half of the time that the model prices are less than the market prices in December series. For at-the-money, in-the-money and out-of-the-money of March and June 2009 series, however, the model prices are generally higher than the market prices. This is because the volatility in stock price process assumed in the binomial tree is quite high. Specifically, we set the implied volatility to 10% which allows the price change to 31.96% in one month. However, the one-month percentage change in price of December, March and June series are 14.99%, 6.84% and 3.5%, respectively. As a result, the model prices are mostly higher than the market prices. However, this relatively high value of the implied volatility will make our arbitrage trading strategy more conservative.

Since the model prices are frequently higher than the market prices for out-of-the-money call option series, we are able to examine the arbitrage trading strategy in the next section.

### C. Findings

The trading strategy of shorting options and buying underlying stocks will be established to examine an arbitrage opportunity if the option price from the model is less than the market option price (option is overpriced). A one-month (before the option's maturity) sample period is considered for each of the three maturities: December, March and June. A portfolio will be constructed to replicate the option payoff at maturity and will be rebalanced every day. By using our model with liquidity and transaction costs, the positive profit after deducting the trading costs can be pre-identified based on an arbitrage opportunity by selling the option and replicating its payoffs. However, we note that the trading costs are the transaction cost and the cost of buying/selling the option which is approximately 90.95 baht per one option contract. Since the fixed cost of trading an option is 90.95 baht, we will not trade if the pre-identified profit is less than that cost. Moreover, SET50 index is untradeable hence we will trade the TDEX instead. We will buy the TDEX at its ask price and sell at its bid price.

For the tables in Appendix D, each row of each table represents the beginning trading day and each column characterizes the strike price. For example, in Table 18, if date = 4, strike price = 280, then maturity = 15. The first trading day starts on December 4, 2008 and the replicating portfolio will be rebalanced every day until maturity. The profit of selling option and replicating portfolio equals to 381.67 baht. The profit in each row and column is the total profit earned at the liquidating date (Maturity). In the December and March trading periods, our trading strategy generates positive profit for most cases. On the other hand, there is one more negative earning than positive earnings in June.

We make profits for 95 times of out 99 times that we decided to trade in December. When we make a profit, the average profit is 652.09 baht, while when we lose, the average loss is 281.49 baht. In March, our strategy still creates average profit about 216.93 baht for 24 days out of 28 days. However, for June period, an average profit is only 231.51 baht for 10 days out of 23 days while average loss is 402.46 baht for 13 days. The net profit of December and March is 614.37 baht and 178.71 baht, respectively. In contrast, the net loss in June is 126.82 baht. Table 7 summarizes these results.

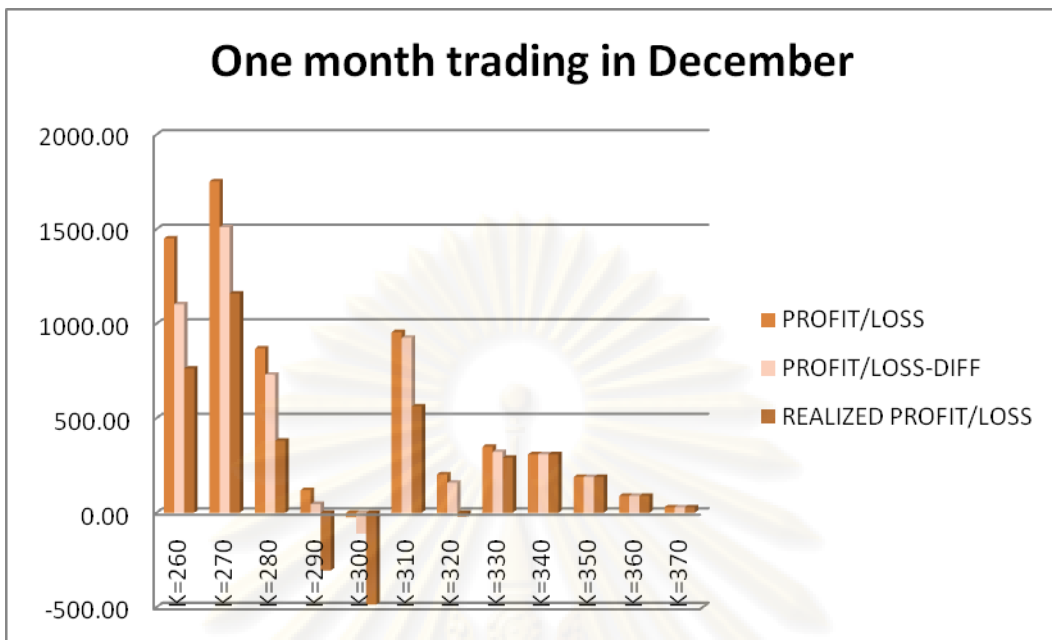


**Table 7: Summary of Profit/Loss in December, March and June**

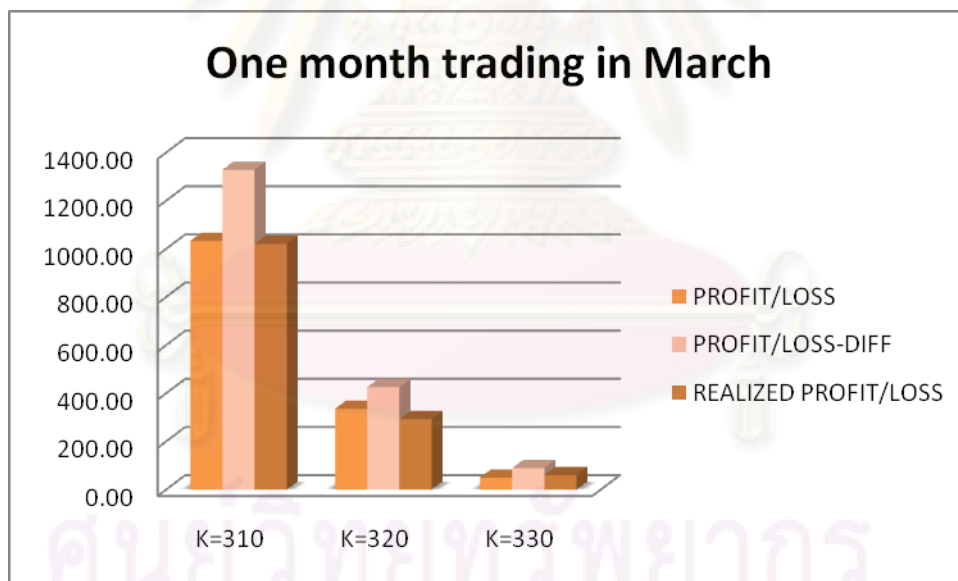
	PROFIT					LOSS					NET PROFIT
	AVERAGE	MAX	MIN	%	DAYS	AVERAGE	MAX	MIN	%	DAYS	
DECEMBER	652.09	2481.48	9.05	95.96	95	-281.49	-486.09	-20.23	4.04	4	614.37
MARCH	216.93	1020.98	20.66	14.29	24	-50.61	-178.89	-2.13	14.29	4	178.71
JUNE	231.51	690.17	3.59	43.48	10	-402.46	-1111.10	-31.02	56.52	13	-126.82

The profit and loss can be decomposed into 4 parts. The first one is transaction cost (TCOST). This cost always has a negative sign and will be deducted from the earnings. The second is the liquidity cost (LCOST). This cost is similar to TCOST and its value is negative. The third part is the DIFF which is the sum of differences between TDEX and SET50 multiplied by the number of stock bought/sold. If the TDEX is greater than SET50, this means that we will buy (sell) TDEX at a high price which is bad (good) for us and DIFF is positive (negative). On the other hand, if TDEX is less than SET50, we will buy (sell) stock at a low price which is good (bad) for us and DIFF is negative (positive). Note that this parameter is an uncontrolled factor and will affect the profit of our trading strategy.

Figure 39, 40 and 41 exhibit the effect of DIFF on profit and loss of one month trading in December, March and June. PROFIT/LOSS is the gross profit before deducting any costs while PROFIT/LOSS – DIFF is the gross profit after deducting only DIFF. This will present the effect of DIFF factor on our profit and loss. REALIZED P/L is the net profit/loss after concerning all costs: DIFF, TCOST and LCOST. In December, DIFF is typically bad and thus reduces (increases) the profit (loss). At  $K=290$ , though the profit after deducting DIFF is positive, the realized profit is negative because of high TCOST and LCOST. In March, DIFF is good for us, thus this factor increase our profit. After deducting all costs, the realized profit is still positive. However, in June, LOSS – DIFF is more negative because DIFF is bad for us and thus pushes the loss up (more loss). Consequently, the realized loss is greater because it have to include all negative costs incurred.

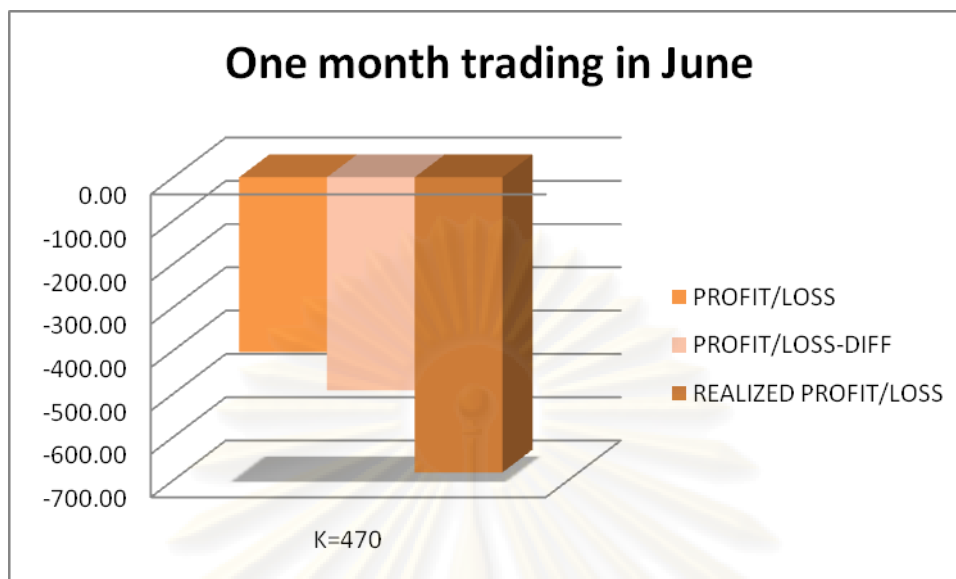


**Figure 39:** Profit/loss comparing with and without DIFF in December



**Figure 40:** Profit/loss comparing with and without DIFF in March

ศูนย์วิจัยทรัพยากร  
จุฬาลงกรณ์มหาวิทยาลัย

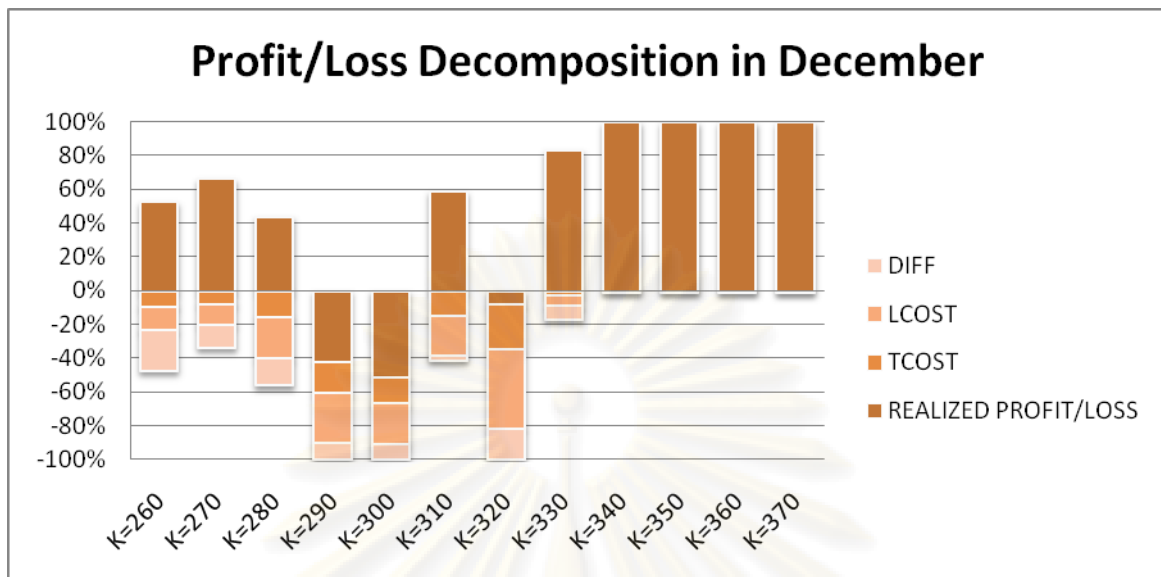


**Figure 41:** Profit/loss comparing with and without DIFF in June

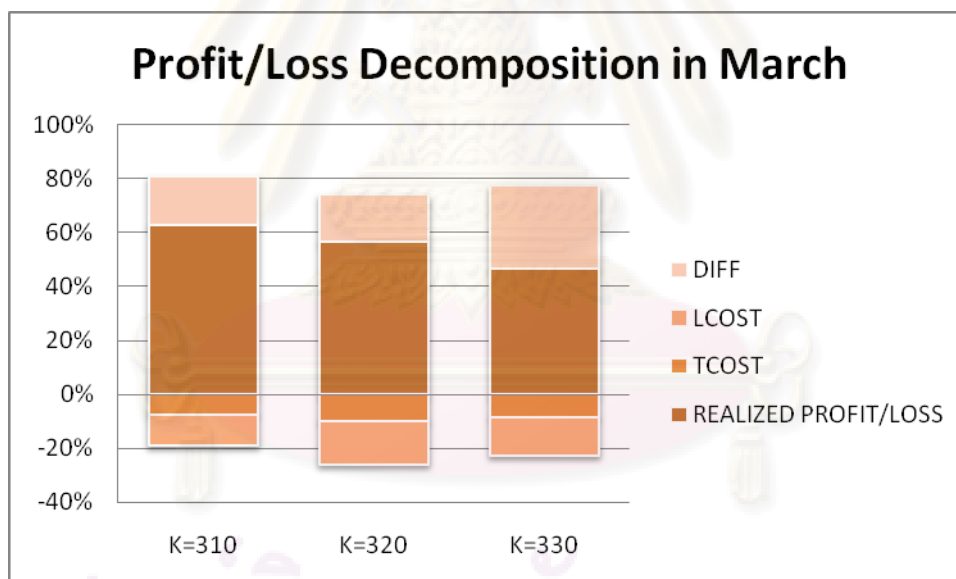
The following figures illustrate the profit and loss decomposition of one month trading in December, March and June. The full bar represents the gross profit/loss. This profit can be decomposed into TCOST, LCOST, DIFF and realized profit. The LCOST is typically greater than the TCOST in all three trading periods. The DIFF can be negative or positive value depending on TDEX, SET50 and trading direction (buying or selling stock). The last component is the realized profit (loss) which is the real profit (loss) by using our trading strategy after eliminating the liquidity cost, transaction cost and the uncontrolled factor (DIFF). In brief, we can include this relationship into the following equation:

$$\text{REALIZED P/L} = \text{PROFIT/LOSS} - \text{TCOT} - \text{LCOST} - \text{DIFF} \quad (17)$$

ศูนย์วิทยทรัพยากร  
จุฬาลงกรณ์มหาวิทยาลัย

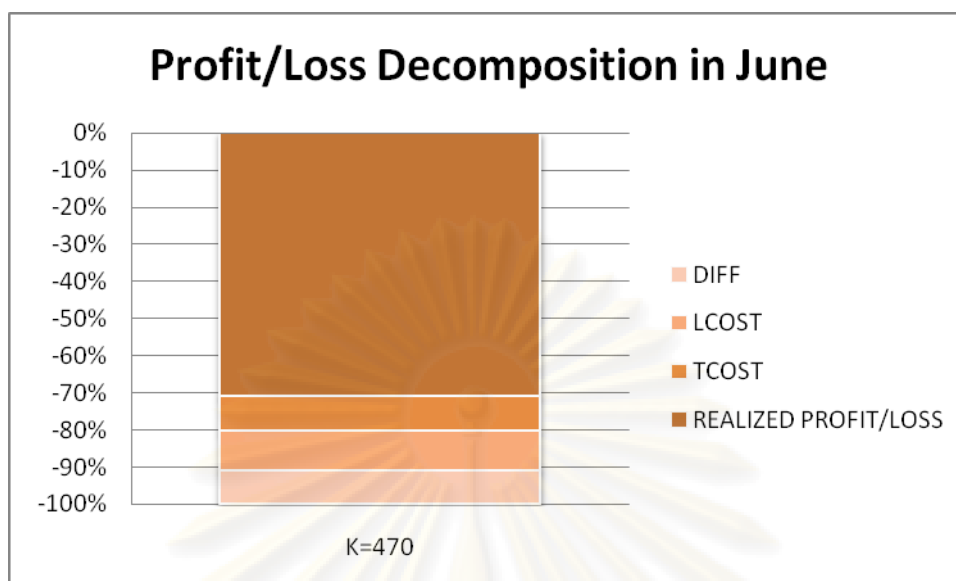


**Figure 42:** Profit/Loss decomposition of 1-month trading in December



**Figure 43:** Profit/Loss decomposition of 1-month trading in March

จุฬาลงกรณ์มหาวิทยาลัย



**Figure 44:** Profit/Loss decomposition of 1-month trading in June

The expected profits are calculated and demonstrated in Appendix D. Note that the expected profit is the different between the model price and the market price. The difference between the real and expected profit is in Appendix E. In December and June, the real profit is less than expected. As a result, most of the errors have negative values. This is different from the March period where real earnings are higher than expected.

The liquidity and transaction costs are shown in Appendix F. Normally, the transaction costs depend on the trading volume. If the trading size is large, the transaction costs will be high. Our results demonstrate that the transaction costs of the options with longer time to maturity are often greater than that of the options with shorter time to maturity (comparing at a similar strike price). The liquidity cost can be computed by multiplying the trading units with the half of the difference between the bid price and ask price of TDEX. The liquidity cost is fluctuated and generally lowest as time to maturity is shortest.

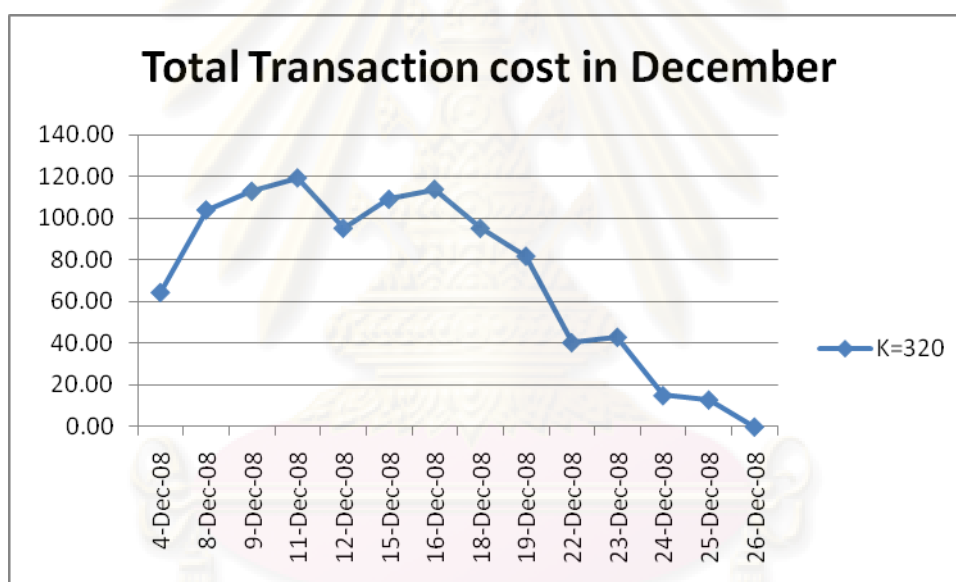
Table 8 below summarizes the average value of TCOST, LCOST and DIFF in each trading period. The average transaction cost is highest in December and lowest in March. An average liquidity cost is similar to transaction cost which has the highest value in December, but its lowest value is in June. For DIFF parameter, there are more negative DIFF ( $TDEX < SET50$ ) in December and March but less in June. However, on average, DIFF is positive in December and June but negative in March. Figure 45 to 50 exhibit the liquidity and transaction costs incurred by exploiting the trading strategy in December,

March and June with different strike prices in each month. In Appendix G, provides more examples.

**Table 8:** Summary of average transaction cost, liquidity cost and diff

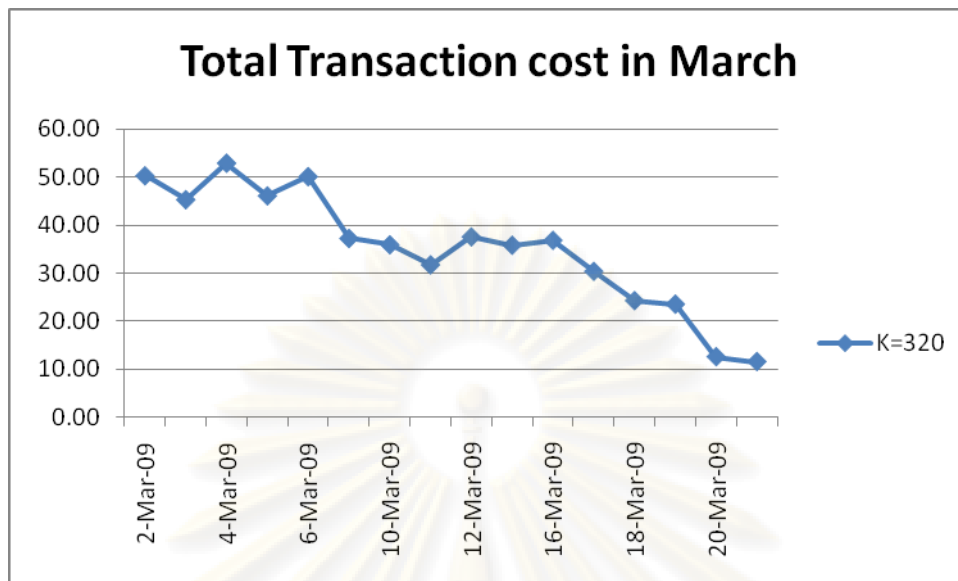
	DECEMBER	MARCH	JUNE
AVERAGE TCOST	48.61	45.59	45.85
AVERAGE LCOST	82.51	76.85	51.04
AVERAGE DIFF	16.53	-33.07	15.48
AVERAGE DIFF (+)	75.99 (44)	33.06 (9)	48.50 (14)
AVERAGE DIFF (-)	-31.60 (54)	-64.39 (19)	-35.87 (9)

\* (·) is the number of days

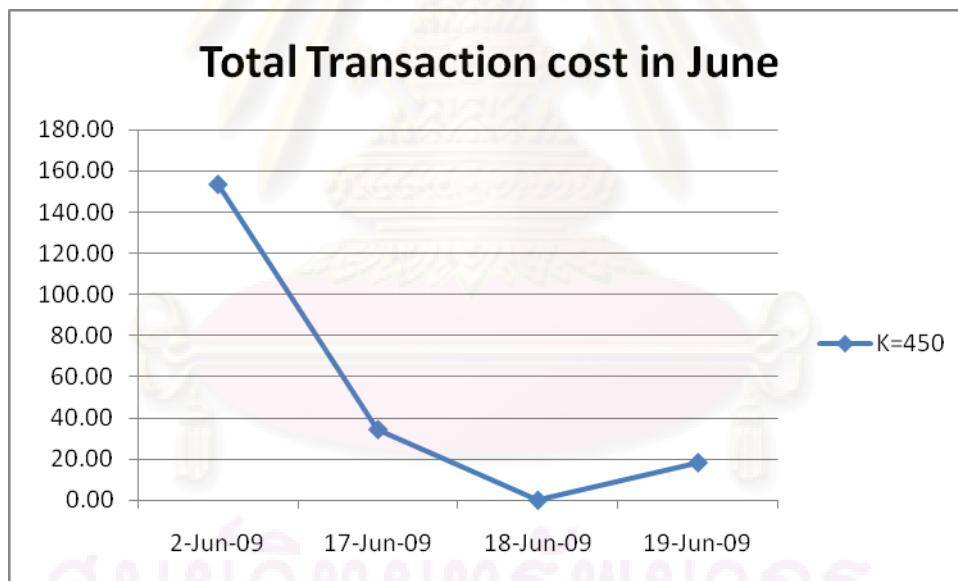


**Figure 45:** Total transaction costs of daily-rebalancing portfolio during December

ศูนย์วิทยทรัพยากร  
จุฬาลงกรณ์มหาวิทยาลัย

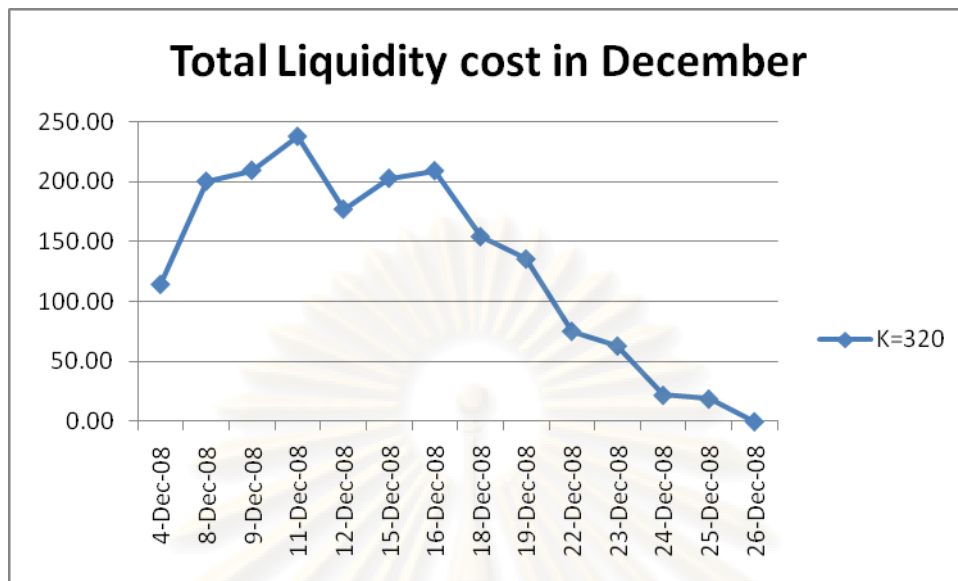


**Figure 46:** Total transaction costs of daily-rebalancing portfolio during March

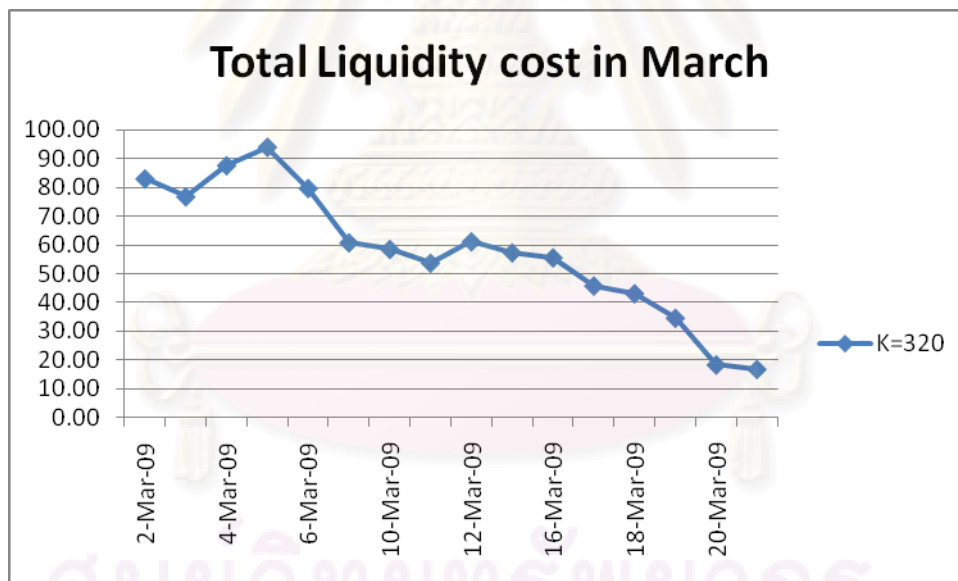


**Figure 47:** Total transaction costs of daily-rebalancing portfolio during June

จุฬาลงกรณ์มหาวิทยาลัย



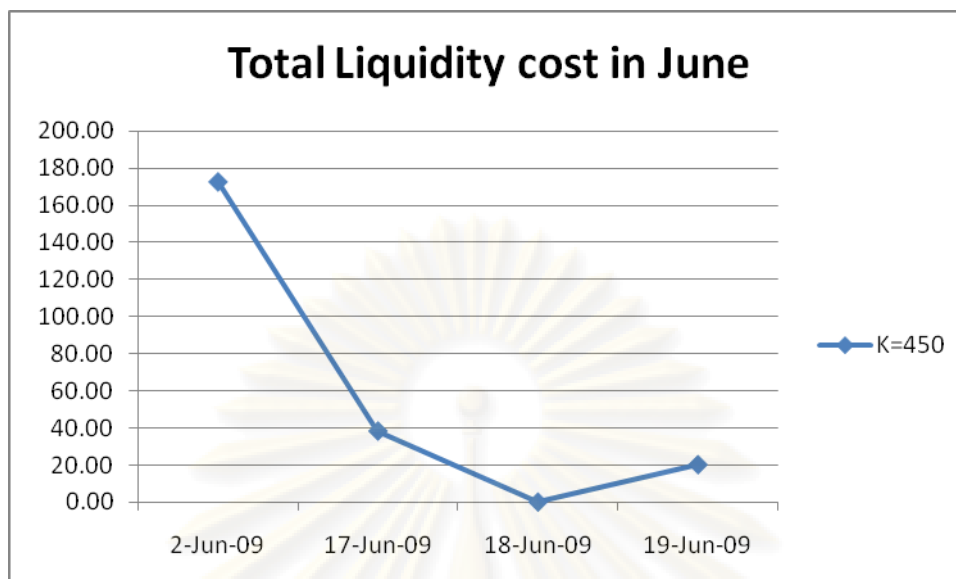
**Figure 48:** Total liquidity costs of daily-rebalancing portfolio during December



**Figure 49:** Total liquidity costs of daily-rebalancing portfolio during March

จุฬาลงกรณ์มหาวิทยาลัย





**Figure 50:** Total liquidity costs of daily-rebalancing portfolio during June

All in all, the trading strategy of buying stocks and selling overpriced options mostly succeeds to generate positive profits in the Thai market. However, this study only accounts for the liquidity and transaction costs. In the real world, there are other factors affecting the option prices such as the difference between SET 50 index and TDEX. As a result, the profitability of our arbitrage trading strategy might not imply the existence of real arbitrage opportunities. This issue is left for future studies.

## CHAPTER VI

### CONCLUSION

This study develops the option valuation model with liquidity and transaction costs in the underlying security market. A discrete trading strategy is employed to investigate the option prices. This analysis is conducted using the data of European call options from the Thai option market. We only consider the proportional transaction fee which is consistent with the fee structure of the market. The liquidity cost is incorporated into the model in the form of a stochastic supply curve, assuming that the underlying prices depend on trading directions and transaction sizes. The results show that the estimated liquidity parameters are significantly positive and very small. This positivity of this parameter confirms that the supply curve is upward sloping. We found that option prices obtained from the model deviate from market prices in many cases. An arbitrage trading strategy of buying stock and selling (overpriced) option is demonstrated by introducing the annualized implied volatility of 10%. With daily rebalancing of the replicating portfolio, the trading strategy typically produces the positive profits (after deducting all the liquidity and transaction costs) in the Thai market. However, we note that this finding does not suggest the existence of arbitrage opportunities, especially as in the real world, there are other factors affecting the option prices.

ศูนย์วิทยพัชกร  
จุฬาลงกรณ์มหาวิทยาลัย

## REFERENCES

- Acharya, V., and L. Pedersen. 2005. Asset Pricing with Liquidity Risk. Journal of Financial Economics 77 (August 2005): 375-410.
- Amihud, Y. and Mendelson, H. 1991. Liquidity, Maturity, and the Yields on US. Treasury Securities. Journal of Finance 46 (September 1991): 1411-1425.
- Bank, P. and Baum, D. 2004. Hedging and Portfolio Optimization in Financial Markets with a Large Trader. Mathematical Finance 14 (January 2004): 1-18.
- Bensaid, B., J. Lesne, H. Pages, and J. Scheinkman. 1992. Derivative Asset Pricing with Transaction Costs. Mathematical Finance 2, 2 (April 1992): 63-86.
- Boyle, P., and T. Vorst. 1992. Option Replication in Discrete Time with Transaction Costs. Journal of Financial 47, 1 (March 1992): 271–293.
- Brenner, M., R. Eldor, S. Hauser. 2001. The Price of Options Illiquidity. Journal of Finance 56, 2 (April 2001): 789-805.
- Carr, P. P., E. C. Chang, and D. B. Madan. 1998. The Variance-Gamma Process and Option Pricing. European Finance Review 2, 1: 79-105.
- Çetin, U., R. Jarrow, and P. Protter. 2004. Liquidity Risk and Arbitrage Pricing Theory. Finance and Stochastics 8, 3: 311–341.
- Cetin, U., R. Jarrow, P. Protter, M. Warachka. 2006. Pricing options in an extended Black-Sholes economy with illiquidity: theory and empirical evidence. The Review of Financial Studies 19 (2006): 493-529.
- Chen, Z., W. Stanzl, and M. Watanabe. 2001. Price Impact Costs and the Limit of Arbitrage. Working Paper, Yale School of Management. February 2001.

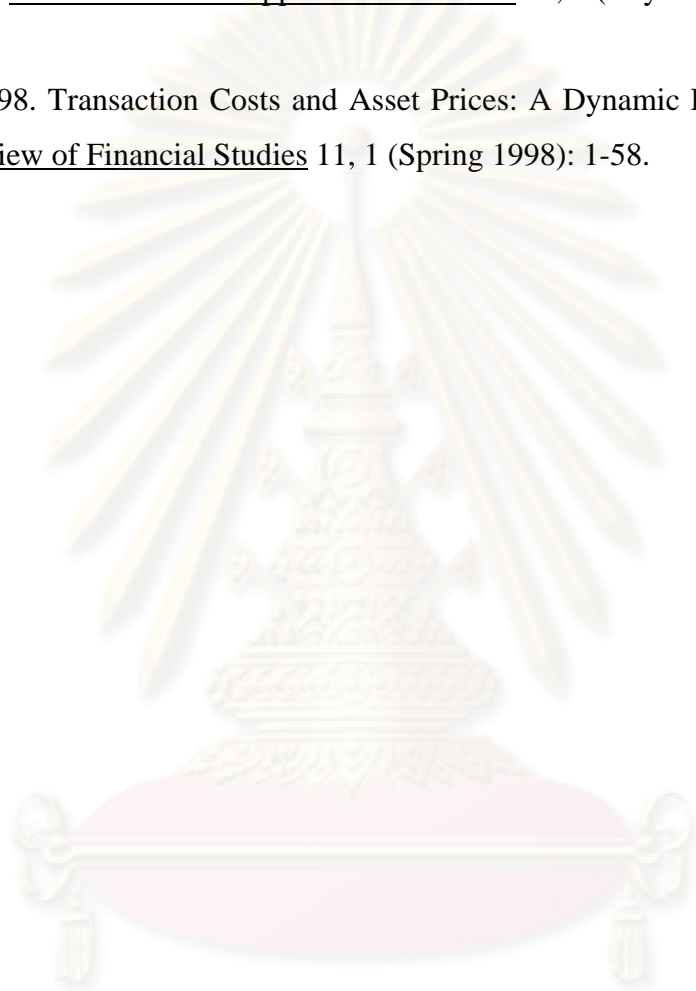
- Cheridito, P. 2003. Arbitrage in Fractional Brownian Motion Models. Finance and Stochastics 7, 4: 533–553.
- Cherubini, U., and G. D. Lunga. 2001. Liquidity and Credit Risk. Applied Mathematical Finance 8, 2: 79-95.
- Chordia, T., R. Roll, and A. Subrahmanyam. 2002. Order imbalance, Liquidity and Market Returns. Journal of Financial Economics 65, 1 (July 2002): 111-130.
- Constantinides, G. 1986. Capital Market Equilibrium with Transactions Costs. Journal of Political Economy 94, 4 (August 1986): 842-862.
- Cox, J. C, S. Ross, and M. Rubinstein. 1979. Option Pricing: A Simplified Approach. Journal of Financial Economics 7, 3 (September 1979): 229-263.
- Dumas, B., and E. Luciano. 1991. An Exact Solution to a Dynamic Portfolio Choice Problem under Transactions Costs. Journal of Finance 46, 2 (June 1991): 577-595.
- Edirisinghe, C., V. Naik, and R. Uppal. 1993. Optimal Replication of Options with Transactions Costs and Trading Restrictions. Journal of Financial and Quantitative Analysis 28, 1 (March 1993): 117-138.
- Ericsson, J., and Renault, O. 2001. Liquidity and credit risk. Working paper, McGill University and Universite Catholique de Louvain.
- Figlewski, S. 1989. Options Arbitrage in Imperfect Markets. Journal of Finance 44, 5 (December 1989): 1289- 1311.
- Frey, R. 1998. Perfect Option Hedging for a Large Trader. Finance and Stochastics 2, 2: 115–141.
- Gennotte, G., and A. Jung. 1994. Investment Strategies under Transactions Costs: The Finite Horizon Case. Management Science 40, 3 (March 1994): 385-404.

- Grossman, S., and G. Laroque. 1990. Asset Pricing and Optimal Portfolio Choice in the Presence of Illiquid Durable Consumption Goods. Econometrica 58, 1 (January 1990): 25-51
- Jarrow, R. 2001. Default Parameter Estimation Using Market Prices. Financial Analysts Journal 57, 5 (September-October 2001): 75-92.
- Jarrow, R. and S. Turnbull. 1997. An Integrated Approach to the Hedging and Pricing of Eurodollar Derivatives. Journal of Risk and Insurance 64, 2 (June 1997): 271-299.
- Lee, C. M. C., and M. J. Ready. 1991. Inferring Trade Direction from Intraday Data. Journal of Finance 46, 2: 733-746.
- Leland, H. 1985. Option Pricing and Replication with Transaction Costs. Journal of Finance 49, 5 (December 1985): 1283-1301.
- Levental, S. and Skorohod, A. V. 1997. On the possibility of hedging options in the presence of transaction costs. The Annals of Applied Probability 7, 2: 410-443.
- Liu, H. and J. Yong. 2005. Option Pricing with an Illiquid Underlying Asset Market. Journal of Economic Dynamics and Control 29, 12 (December 2005): 2125-2156.
- Loeb, T. F. 1983. Trading Cost: The Critical Link between Investment Information and Results. Financial Analysts Journal 39 (May-June 1983): 39-44.
- Merton, R. C. 1976. Option Pricing When Underlying Stock Returns are Discontinuous. Journal of Finance Economics 3 (1976): 125-144.
- Platen, E., and M. Schweizer. 1998. On Feedback Effects from Hedging Derivatives. Mathematical Finance 8, 1 (January 1998): 67-84.

Rogers, C., and O. Zane. A simple model of liquidity [Online]. 1998. Available from:  
<http://www.statslab.cam.ac.uk/~chris/papers/lq2.pdf>

Schonbucher, P., and P. Wilmott. 2000. The Feedback Effect of Hedging in Illiquid Markets. SIAM Journal on Applied Mathematics 61, 1 (July 2000): 232–272.

Vayanos, D. 1998. Transaction Costs and Asset Prices: A Dynamic Equilibrium Model. The Review of Financial Studies 11, 1 (Spring 1998): 1-58.



ศูนย์วิทยทรัพยากร  
จุฬาลงกรณ์มหาวิทยาลัย



**APPENDICES**

ศูนย์วิทยทรัพยากร  
จุฬาลงกรณ์มหาวิทยาลัย

## APPENDIX A

**Table 9: The terms of SET50 Index**

Index code	SET50 Index
Index Type	Composite Index
Calculation Methodology	<p>The same as that used for the SET Index.</p> <ul style="list-style-type: none"> <li>• A market capitalization-weighted price index</li> <li>• Excluded are stocks that have been suspended for more than one year.</li> <li>• Calculated from the prices of 50 selected SET stocks.</li> </ul>
Base value adjustment	<p>The base market value is continually adjusted to correspond to changes in the values of securities that result from changes in the number of stocks. This number may change due to public offerings, exercised warrants, and conversions of preferred to common shares.</p>
Base value	1,000 points
Base date	August 16, 1995

Source: [www.set.or.th](http://www.set.or.th)

Note that SET50 Index was launched to provide a benchmark of investment in the Stock Exchange of Thailand and to accommodate the issuing of index futures and options in derivatives market. This index is calculated from the stock prices of the top 50 listed companies on SET. These companies are chosen in term of large market capitalization, high liquidity and compliance with requirements regarding the distribution of shares to minor shareholders. The component stocks of SET50 Index are reviewed every six months in order to adjust for any changes that have occurred in the stock market. After assessment, stocks that meet the necessary qualifications are selected to become parts of the SET50 Index and others are removed.



**Table 10: Summary of SET50 Index Options Contract Specifications**

<b>Heading</b>	<b>Individual Contract specification</b>
Underlying index	SET50 Index which is compiled, computed and disseminated by the Stock Exchange of Thailand
Contract Multiplier	200 Baht per index point
Contract Months	March, June, September, December up to 4 quarters
Minimum price fluctuations	0.10 index points
Price Limit	+/- 30% of the previous day's SET50 Index
Exercise style	European
Strike price interval	10 points (at least 5 in-the-money strikes, 5 out-of-the-money strikes and 1 at-the-money strike).
Trading Hours	Pre-open: 9:15 - 9:45 hrs. Morning session: 9:45 - 12:30 hrs. Pre-open: 14:00 - 14:30 hrs. Afternoon session: 14:30 - 16:55 hrs.
Speculative Position limit	Net 20,000 delta equivalent SET50 Index Futures contracts on one side of the market in any contract month or all contract months combined.
Final Trading Day	The business day immediately preceding the last business day of the contract month. Time at which trading ceases on Final Trading Day is 16:30 hrs.
Final Settlement Price	The final settlement price shall be the numerical value of the SET50 Index, rounded down to the nearest two decimal points as determined by the exchange, and shall be the average value of the SET50 Index taken during last 15 minutes plus the closing index value, after deleting the three highest and three lowest values.
Settlement Procedures	Cash Settlement
Exchange and clearing fee	THB 10 per contract per side
Brokerage commission	Freely negotiable

Source: [www.tfex.co.th](http://www.tfex.co.th)

Note that SET50 Index Options were launched on October 29, 2007 by Thailand Futures Exchange Pcl (TFEX) to complement the SET50 Index Futures. This new financial product offered investors an opportunity to limit the risks of undesirable market direction and take advantage on anticipated market movements. As a result, it will help protect the investors' equity portfolio value.

**Table 11: Summary of ThaiDex SET50 ETF Information**

Fund Code	<b>TDEX</b>
Fund Number	10070
Type of Fund	Open-Ended Equity Exchange Traded Fund
Registered Fund Size	Baht 10,000 Million
Inception Date	September 4, 2007
Listing Date on SET	September 6, 2007
Trustee	Citibank, N.A. Bangkok branch
Registrar	The Thailand Securities Depository Co., Ltd.
Fiscal Year	December 31 of each year (The first fiscal year will be December 31, 2008.)
Dividend Policy	The fund has a policy to pay dividend to unit holders from accumulated profit or net profit when the fund has accumulated profit or net profit in the interim accounting period to pay dividend and such dividend payment shall not cause the accumulated loss to increase in the interim accounting period to pay dividend. Such dividend payment shall not be more than 4 times per year at a rate of not more than 100 per cent of accumulated profit or net profit as the Management Company (ONEAM) deem appropriate.
Subscription	<p>1) Participating Dealers : Participating Dealers can order the purchase of investment units directly with the Management Company at a minimum order of 1 creation unit and increase in multiple of 1 creation unit, using the price of the trade date of the basket of securities as specified by the Management Company.</p> <p>2) Investors : After registering the asset pool of the fund as a mutual fund with the Office of the SEC, the Management Company will register the investment units of the fund as a listed security on the SET. Investors or participating dealers can purchase investment units of the fund on the SET by complying with the rules, regulations and practice of the SET and investors must have a securities trading account with a securities brokerage company.</p> <p>Investors can purchase investment units by means of delivering the basket of securities through the participating dealers according to steps and procedures specified by the participating dealers.</p>

## Redemption

1) Participating dealers : Participating Dealers can order the sale of investment directly with the Management Company at a minimum order of 1 creation unit and increase in multiple of 1 creation unit on every business day of the SET. The Management Company will pay in kind by the basket of securities according to the ratio and details of securities specified by the Management Company.

2) Investors : After registering the asset pool of the fund as a mutual fund with the Office of the SEC, the Management Company will register the investment units of the fund as a listed security on the SET. Investors or participating dealers can sell investment units of the fund on the SET by complying with the rules, regulations and practice of the SET and investors must have a securities trading account with a securities brokerage company.

Investors can sell investment units by means of paying in kind by the basket of securities through the participating dealers according to steps and procedures specified by the participating dealers.

Dealing Time	Every business day of the Stock Exchange of Thailand
Settlement Date	T+3

Source: [www.one-asset.com](http://www.one-asset.com)

Note that the benchmark index of ThaiDex SET50 ETF is SET50 Index. Therefore, this fund will mainly invest in the securities which are constituents of SET50 Index. Moreover, the objective of this fund is to replicate the return of SET50 Index by trying to maintain the tracking error between the return of the fund and the SET50 Index with no more than 1% per year.

ศูนย์วิทยทรัพยากร  
จุฬาลงกรณ์มหาวิทยาลัย

## APPENDIX B

**Table 12: Estimated option price of December 2008 series**

DATE	STRIKE PRICE(K)																
	210	220	230	240	250	260	270	280	290	300	310	320	330	340	350	360	370
4	14322.3	12320.5	10326.3	8320.0	6329.0	4395.7	2671.7	1353.7	557.9	172.9	35.1	4.6	0.3	0.0	0.0	0.0	0.0
8	17257.8	15251.5	13252.4	11253.3	9250.2	7254.2	5282.6	3440.3	1916.2	871.5	318.6	78.3	12.6	1.0	0.0	0.0	0.0
9	19554.0	17557.1	15556.6	13554.7	11556.3	9557.1	7555.9	5575.4	3702.0	2118.3	986.0	357.5	94.2	15.9	1.3	0.0	0.0
11	19774.2	17778.5	15782.3	13778.7	11776.7	9778.3	7778.2	5784.4	3875.4	2223.0	1029.7	366.3	91.4	13.5	0.7	0.0	0.0
12	19759.9	17757.2	15754.6	13757.7	11756.2	9754.6	7755.1	5761.5	3833.5	2160.3	963.2	315.0	65.2	6.4	0.0	0.0	0.0
15	21725.9	19724.0	17726.6	15726.6	13725.7	11722.7	9725.9	7726.5	5726.1	3792.9	2107.6	913.6	284.8	54.1	4.1	0.0	0.0
16	23067.6	21065.6	19069.7	17072.5	15068.8	13066.3	11069.4	9066.1	7065.2	5075.2	3175.8	1601.9	600.3	144.8	15.8	0.0	0.0
17	23212.7	21209.1	19212.9	17214.7	15211.3	13213.2	11208.8	9211.1	7208.6	5211.9	3271.3	1634.3	584.8	122.2	7.4	0.0	0.0
18	24134.6	22130.8	20134.3	18131.4	16139.3	14134.0	12135.6	10130.8	8135.5	6130.8	4138.8	2284.6	915.0	217.7	14.3	0.0	0.0
19	23157.0	21161.1	19156.7	17160.7	15159.3	13157.0	11157.4	9158.1	7159.0	5156.7	3175.7	1443.5	398.7	27.5	0.0	0.0	0.0
22	20970.7	18969.5	16973.4	14969.0	12969.0	10970.7	8973.2	6979.6	4970.0	2973.2	1193.1	199.7	0.0	0.0	0.0	0.0	0.0
23	21890.2	19895.7	17893.8	15890.2	13890.2	11890.2	9895.7	7895.7	5895.7	3890.2	1890.1	384.8	0.0	0.0	0.0	0.0	0.0
24	21529.1	19529.1	17529.1	15529.1	13529.1	11529.1	9529.1	7529.1	5529.1	3529.1	1529.1	70.7	0.0	0.0	0.0	0.0	0.0
25	21930.0	19930.0	17930.0	15930.0	13930.0	11930.0	9930.0	7930.0	5930.0	3930.0	1930.0	110.4	0.0	0.0	0.0	0.0	0.0
26	21464.2	19464.2	17464.2	15464.2	13464.2	11464.2	9464.2	7464.2	5464.2	3464.2	1464.2	0.0	0.0	0.0	0.0	0.0	0.0

**Table 13: Estimated option price of March 2009 series**

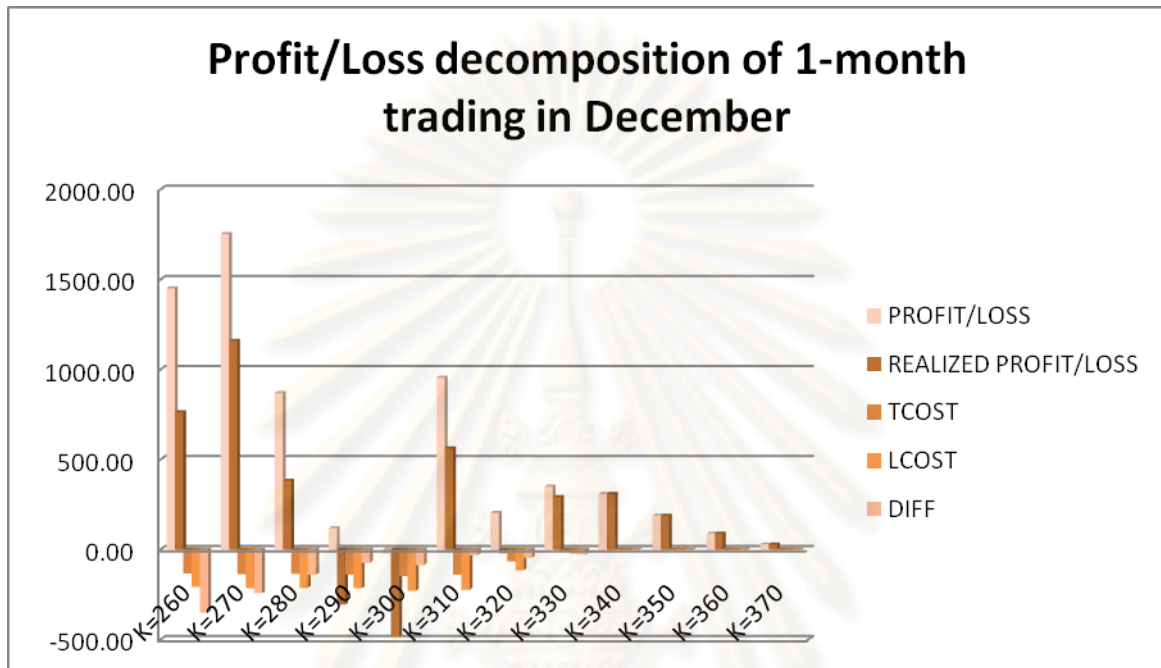
DATE	STRIKE PRICE(K)												
	230	240	250	260	270	280	290	300	310	320	330	340	350
2	13489.4	11487.4	9488.4	7503.8	5578.9	3806.2	2333.4	1258.2	577.9	225.0	71.7	18.1	3.4
3	12893.9	10892.7	8895.5	6912.7	5007.3	3298.4	1909.9	952.8	402.5	140.0	38.5	8.0	1.1
4	13652.6	11656.0	9653.4	7661.1	5708.0	3894.7	2366.2	1238.8	549.5	200.3	57.8	12.5	1.8
5	13578.2	11580.4	9579.6	7585.6	5629.4	3808.9	2279.8	1159.5	490.3	167.7	44.3	8.5	1.0
6	14867.0	11956.5	9954.3	7959.6	5982.3	4113.9	2501.4	1293.1	553.2	189.5	55.8	8.9	1.0
9	12665.5	10665.0	8664.5	6673.5	4732.3	2978.2	1591.0	695.6	238.7	59.8	9.7	0.8	0.0
10	13782.3	11785.2	9780.5	7779.8	5798.8	3910.3	2287.0	1105.0	425.0	122.8	23.9	2.6	0.1
11	13275.0	11274.8	9277.3	7275.7	5296.4	3435.5	1885.1	826.8	275.6	63.8	8.8	0.5	0.0
12	13359.3	11363.0	9360.5	7359.8	5371.5	3482.9	1903.5	810.7	255.2	51.9	4.9	0.0	0.0
13	14969.2	12972.2	10972.9	8971.1	6969.5	4987.5	3126.8	1605.7	633.0	175.5	28.8	1.8	0.0
16	14975.1	12978.9	10974.0	8971.9	6975.9	4983.2	3094.8	1551.5	578.6	139.4	15.4	0.0	0.0
17	14460.7	12459.6	10457.4	8457.3	6456.6	4467.4	2607.1	1165.1	358.3	59.4	2.0	0.0	0.0
18	15101.3	13105.0	11103.2	9100.9	7103.5	5101.9	3154.5	1509.4	492.8	83.5	1.3	0.0	0.0
19	15329.5	13328.4	11328.1	9330.6	7333.3	5334.0	3348.0	1607.6	494.2	65.0	0.0	0.0	0.0
20	15679.1	13682.8	11682.6	9679.1	7679.2	5680.1	3680.2	1816.9	547.2	55.9	0.0	0.0	0.0
23	17095.9	15099.1	13095.9	11099.1	9099.2	7095.9	5099.1	3095.0	1288.4	235.7	0.0	0.0	0.0
24	17066.0	15066.0	13066.0	11060.6	9066.0	7064.1	5065.5	3066.0	1143.8	95.1	0.0	0.0	0.0
25	16775.3	14775.3	12775.3	10775.3	8775.3	6775.3	4775.3	2775.3	773.0	0.0	0.0	0.0	0.0
26	16756.1	14756.1	12756.1	10756.1	8756.1	6756.1	4756.1	2756.1	756.1	0.0	0.0	0.0	0.0
27	16285.1	14285.1	12285.1	10285.1	8285.1	6285.1	4285.1	2285.1	307.7	0.0	0.0	0.0	0.0

**Table 14: Estimated option price of June 2009 series**

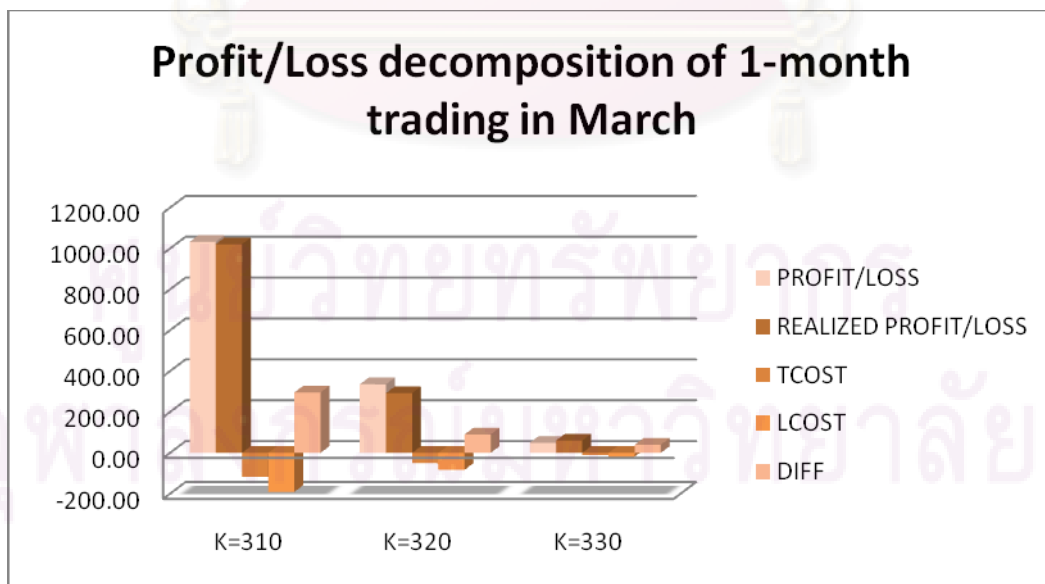
DATE	STRIKE PRICE(K)															
	350	360	370	380	390	400	410	420	430	440	450	460	470	480	490	500
1	15642.3	13639.1	11648.6	9687.3	7781.9	6003.5	4401.9	3042.3	1964.2	1182.6	659.5	339.6	158.8	66.3	24.4	8.3
2	14663.9	12658.7	10680.0	8726.8	6855.3	5133.2	3627.1	2389.7	1464.0	835.8	437.2	200.8	83.8	33.5	9.7	2.7
3	15964.2	13968.4	11972.5	9992.0	8058.5	6221.7	4558.2	3132.4	2004.5	1182.1	641.6	315.3	137.9	54.2	17.9	5.2
4	17841.4	15836.7	13837.9	11846.0	9867.4	7928.8	6097.5	4444.9	3033.0	1921.2	1121.5	594.8	287.6	122.3	46.1	14.5
5	19598.2	17604.5	15599.7	13597.3	11601.9	9622.1	7696.9	5875.2	4237.6	2851.1	1773.8	1010.7	525.3	244.7	99.2	34.2
8	18808.5	16812.9	14807.2	12809.7	10818.5	8845.1	6928.5	5144.6	3580.3	2296.8	1349.1	718.7	353.0	140.7	54.3	13.7
9	20075.0	18069.4	16068.7	14067.0	12074.1	10079.4	8113.9	6232.6	4503.7	3022.0	1854.1	1033.5	515.5	227.4	89.4	24.2
10	23001.0	21004.5	18997.5	17005.0	14998.4	12999.3	11006.0	9022.4	7087.9	5273.2	3656.7	2331.1	1348.3	704.8	320.9	123.6
11	23577.1	21574.1	19572.6	17571.4	15573.2	13575.2	11573.9	9574.7	7614.5	5737.5	4039.6	2610.7	1520.4	805.5	358.1	136.0
12	23836.0	21829.5	19829.1	17828.8	15835.1	13828.5	11830.0	9833.6	7855.1	5937.0	4180.1	2690.5	1553.7	788.7	339.3	117.9
15	21180.7	19181.2	17186.8	15186.2	13181.3	11179.0	9183.8	7200.7	5289.8	3563.8	2146.4	1128.6	497.5	173.1	45.3	7.0
16	18760.0	16759.9	14766.1	12764.4	10765.0	8760.5	6772.5	4854.3	3137.4	1758.2	830.1	310.6	84.1	12.8	0.0	0.0
17	16889.8	14889.6	12891.1	10891.4	8889.2	6893.2	4931.0	3145.7	1712.8	757.2	245.9	46.9	0.6	0.0	0.0	0.0
18	14264.8	12268.0	10264.4	8264.5	6264.5	4306.0	2547.4	1211.7	422.2	83.4	0.0	0.0	0.0	0.0	0.0	0.0
19	17401.4	15403.3	13397.8	11408.7	9396.3	7398.7	5405.2	3471.9	1828.1	714.4	162.1	1.1	0.0	0.0	0.0	0.0
22	16222.6	14225.5	12224.3	10222.0	8222.3	6225.5	4227.7	2351.9	937.8	187.2	0.0	0.0	0.0	0.0	0.0	0.0
23	14194.3	12201.5	10201.5	8199.0	6194.3	4200.8	2203.0	684.2	26.6	0.0	0.0	0.0	0.0	0.0	0.0	0.0
24	16002.3	14002.3	12002.3	10002.3	8002.3	6002.3	4002.3	2002.3	360.9	0.0	0.0	0.0	0.0	0.0	0.0	0.0
25	16898.1	14898.1	12898.1	10898.1	8898.1	6898.1	4898.1	2898.1	904.7	0.0	0.0	0.0	0.0	0.0	0.0	0.0
26	16852.4	14852.4	12852.4	10852.4	8852.4	6852.4	4852.4	2852.4	852.4	0.0	0.0	0.0	0.0	0.0	0.0	0.0

## APPENDIX C

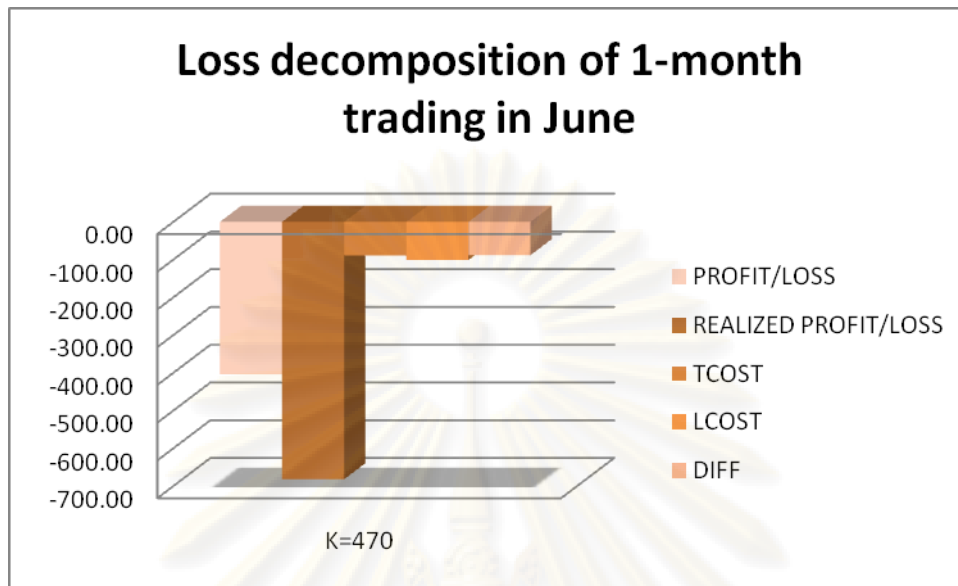
**Figure 51: The Amount of Profit/ Loss Decomposition in December**



**Figure 52: The Amount of Profit/ Loss Decomposition in March**



**Figure 53: The Amount of Profit/ Loss Decomposition in June**



ศูนย์วิทยทรัพยากร  
จุฬาลงกรณ์มหาวิทยาลัย



## APPENDIX D

**Table 15: Expected profit of portfolio replication in December 2008**

DATE	STRIKE PRICE(K)																
	210	220	230	240	250	260	270	280	290	300	310	320	330	340	350	360	370
4	0.00	0.00	0.00	0.00	0.00	424.33	1128.29	946.27	922.09	827.06	1124.87	695.38	579.73	400.00	280.00	180.00	120.00
8	0.00	0.00	0.00	0.00	0.00	0.00	0.00	979.66	1683.77	1128.50	1821.39	1021.67	1007.44	779.01	480.00	340.00	300.00
9	0.00	0.00	0.00	0.00	0.00	0.00	0.00	0.00	98.03	681.75	1554.01	942.48	1285.82	984.14	698.73	500.00	340.00
11	0.00	0.00	0.00	0.00	0.00	0.00	0.00	0.00	0.00	1077.05	1430.25	833.67	608.57	906.48	579.25	420.00	280.00
12	0.00	0.00	0.00	0.00	0.00	0.00	0.00	0.00	126.48	439.66	236.81	1385.05	174.85	833.56	560.00	380.00	240.00
15	0.00	0.00	0.00	0.00	0.00	0.00	0.00	0.00	0.00	0.00	0.00	586.41	1215.21	965.94	675.85	440.00	280.00
16	0.00	0.00	0.00	0.00	0.00	0.00	0.00	0.00	0.00	0.00	0.00	98.14	1259.70	615.16	844.19	560.00	260.00
17	0.00	0.00	0.00	0.00	0.00	0.00	0.00	0.00	0.00	0.00	208.66	0.00	1175.25	1057.82	772.61	500.00	300.00
18	0.00	0.00	0.00	0.00	0.00	0.00	0.00	0.00	0.00	0.00	0.00	235.38	145.04	382.31	865.66	560.00	340.00
19	0.00	0.00	0.00	0.00	0.00	0.00	0.00	0.00	0.00	0.00	24.35	536.48	601.32	472.52	600.00	360.00	200.00
22	0.00	0.00	0.00	0.00	0.00	0.00	0.00	0.00	0.00	0.00	206.90	300.33	600.00	200.00	140.00	0.00	0.00
23	0.00	0.00	0.00	0.00	0.00	0.00	0.00	0.00	0.00	0.00	0.00	375.18	500.00	340.00	160.00	0.00	0.00
24	0.00	0.00	0.00	0.00	0.00	0.00	0.00	0.00	0.00	0.00	0.00	329.35	300.00	220.00	100.00	0.00	0.00
25	0.00	0.00	0.00	0.00	0.00	0.00	0.00	0.00	0.00	0.00	0.00	389.59	200.00	220.00	0.00	0.00	0.00
26	0.00	0.00	0.00	0.00	0.00	0.00	0.00	0.00	0.00	0.00	375.80	920.00	400.00	140.00	0.00	0.00	0.00

**Table 16: Expected profit of portfolio replication in March 2009**

DATE	STRIKE PRICE(K)												
	230	240	250	260	270	280	290	300	310	320	330	340	350
2	0.00	0.00	0.00	0.00	0.00	0.00	0.00	0.00	102.08	134.98	108.35	0.00	0.00
3	0.00	0.00	0.00	0.00	0.00	0.00	0.00	0.00	0.00	219.98	81.52	0.00	0.00
4	0.00	0.00	0.00	0.00	0.00	0.00	0.00	0.00	70.47	119.66	102.21	0.00	0.00
5	0.00	0.00	0.00	0.00	0.00	0.00	0.00	0.00	89.73	112.26	95.75	0.00	0.00
6	0.00	0.00	0.00	0.00	0.00	0.00	0.00	0.00	0.00	130.51	84.24	0.00	0.00
9	0.00	0.00	0.00	0.00	0.00	0.00	0.00	0.00	41.26	60.16	0.00	0.00	0.00
10	0.00	0.00	0.00	0.00	0.00	0.00	0.00	0.00	0.00	37.18	0.00	0.00	0.00
11	0.00	0.00	0.00	0.00	0.00	0.00	0.00	0.00	24.35	56.17	0.00	0.00	0.00
12	0.00	0.00	0.00	0.00	0.00	0.00	0.00	0.00	24.82	48.08	0.00	0.00	0.00
13	0.00	0.00	0.00	0.00	0.00	0.00	0.00	0.00	0.00	44.49	0.00	0.00	0.00
16	0.00	0.00	0.00	0.00	0.00	0.00	0.00	0.00	0.00	20.57	0.00	0.00	0.00
17	0.00	0.00	0.00	0.00	0.00	0.00	0.00	0.00	0.00	40.63	0.00	0.00	0.00
18	0.00	0.00	0.00	0.00	0.00	0.00	0.00	0.00	0.00	36.46	0.00	0.00	0.00
19	0.00	0.00	0.00	0.00	0.00	0.00	0.00	0.00	0.00	55.03	0.00	0.00	0.00
20	0.00	0.00	0.00	0.00	0.00	0.00	0.00	0.00	0.00	64.07	0.00	0.00	0.00
23	0.00	0.00	0.00	0.00	0.00	0.00	0.00	0.00	0.00	0.00	0.00	0.00	0.00
24	0.00	0.00	0.00	0.00	0.00	0.00	0.00	0.00	0.00	44.92	0.00	0.00	0.00
25	0.00	0.00	0.00	0.00	0.00	0.00	0.00	0.00	0.00	0.00	0.00	0.00	0.00
26	0.00	0.00	0.00	0.00	0.00	0.00	0.00	0.00	0.00	0.00	0.00	0.00	0.00
27	0.00	0.00	0.00	0.00	0.00	0.00	0.00	0.00	172.27	0.00	0.00	0.00	0.00

**Table 17: Expected profit of portfolio replication in June 2009**

DATE	STRIKE PRICE(K)															
	350	360	370	380	390	400	410	420	430	440	450	460	470	480	490	500
<b>1</b>	0.00	0.00	0.00	0.00	0.00	0.00	0.00	0.00	0.00	0.00	0.00	0.00	1.25	0.00	0.00	0.00
<b>2</b>	0.00	0.00	0.00	0.00	0.00	0.00	0.00	0.00	0.00	0.00	162.83	99.24	16.17	0.00	0.00	0.00
<b>3</b>	0.00	0.00	0.00	0.00	0.00	0.00	0.00	0.00	0.00	0.00	0.00	0.00	0.00	0.00	0.00	0.00
<b>4</b>	0.00	0.00	0.00	0.00	0.00	0.00	0.00	0.00	0.00	0.00	0.00	0.00	0.00	0.00	0.00	0.00
<b>5</b>	0.00	0.00	0.00	0.00	0.00	0.00	0.00	0.00	0.00	0.00	0.00	0.00	0.00	0.00	0.75	0.00
<b>8</b>	0.00	0.00	0.00	0.00	0.00	0.00	0.00	0.00	0.00	0.00	0.00	0.00	0.00	0.00	0.00	0.00
<b>9</b>	0.00	0.00	0.00	0.00	0.00	0.00	0.00	0.00	0.00	0.00	0.00	0.00	0.00	0.00	0.00	0.00
<b>10</b>	0.00	0.00	0.00	0.00	0.00	0.00	0.00	0.00	0.00	0.00	0.00	0.00	0.00	0.00	0.00	0.00
<b>11</b>	0.00	0.00	0.00	0.00	0.00	0.00	0.00	0.00	0.00	0.00	0.00	0.00	0.00	0.00	0.00	0.00
<b>12</b>	0.00	0.00	0.00	0.00	0.00	0.00	0.00	0.00	0.00	0.00	0.00	0.00	0.00	0.00	0.00	2.12
<b>15</b>	0.00	0.00	0.00	0.00	0.00	0.00	0.00	0.00	0.00	0.00	0.00	0.00	0.00	0.00	0.00	0.00
<b>16</b>	0.00	0.00	0.00	0.00	0.00	0.00	0.00	0.00	0.00	0.00	0.00	89.37	15.92	0.00	0.00	0.00
<b>17</b>	0.00	0.00	0.00	0.00	0.00	0.00	0.00	0.00	0.00	0.00	114.11	133.08	0.00	0.00	0.00	0.00
<b>18</b>	0.00	0.00	0.00	0.00	0.00	0.00	0.00	668.33	0.00	316.59	180.00	0.00	0.00	0.00	0.00	0.00
<b>19</b>	0.00	0.00	0.00	0.00	0.00	0.00	0.00	0.00	0.00	25.59	77.90	138.93	0.00	0.00	0.00	0.00
<b>22</b>	0.00	0.00	0.00	0.00	0.00	0.00	0.00	0.00	0.00	12.80	0.00	0.00	0.00	0.00	0.00	0.00
<b>23</b>	0.00	0.00	0.00	0.00	0.00	0.00	0.00	0.00	113.43	0.00	0.00	0.00	0.00	0.00	0.00	0.00
<b>24</b>	0.00	0.00	0.00	0.00	0.00	0.00	0.00	0.00	19.12	100.00	0.00	0.00	0.00	0.00	0.00	0.00
<b>25</b>	0.00	0.00	0.00	0.00	0.00	0.00	0.00	0.00	0.00	400.00	0.00	0.00	0.00	0.00	0.00	0.00
<b>26</b>	0.00	0.00	107.55	0.00	0.00	0.00	0.00	0.00	0.00	260.00	0.00	0.00	0.00	0.00	0.00	0.00

**Table 18: Profit/Loss of portfolio replication in December 2008**

DATE	STRIKE PRICE(K)																
	210	220	230	240	250	260	270	280	290	300	310	320	330	340	350	360	370
4	0	0	0	0	0	762.9	1160	381.67	-305.63	-486.09	562.12	-20.23	290.87	309.1	189.1	89.05	29.05
8	0	0	0	0	0	0	0	1485.1	2134.8	1285.7	2008.9	386.6	475.8	643.7	389.1	249.1	209.1
9	0	0	0	0	0	0	0	0	1626.2	1863.2	2481.5	723.2	900.27	872.7	609.2	409.1	249.1
11	0	0	0	0	0	0	0	0	0	2133.6	2205.6	466.9	123.27	761.3	488.7	329.1	189.1
12	0	0	0	0	0	0	0	0	1385.1	1406.1	951.38	994.5	-314.02	704.6	469.1	289.1	149.1
15	0	0	0	0	0	0	0	0	0	0	0	500	919.58	892.9	591.4	349	189
16	0	0	0	0	0	0	0	0	0	0	0	237.7	1042.7	559.3	763.7	469	169
17	0	0	0	0	0	0	0	0	0	0	1641.4	0	956.6	988.8	686.5	409	209
18	0	0	0	0	0	0	0	0	0	0	0	822.2	27.126	311.9	778.9	469	249
19	0	0	0	0	0	0	0	0	0	0	1761.2	578.7	265.32	327.2	509.1	269.1	109.1
22	0	0	0	0	0	0	0	0	0	0	1706.1	535.3	509.05	109	49.05	0	0
23	0	0	0	0	0	0	0	0	0	0	0	673	409.05	249.1	69.05	0	0
24	0	0	0	0	0	0	0	0	0	0	0	319.7	209.05	129	9.05	0	0
25	0	0	0	0	0	0	0	0	0	0	0	396.1	109.05	129	0	0	0
26	0	0	0	0	0	0	0	0	0	0	1276.9	829	309.05	49.05	0	0	0

**Table 19: Profit/Loss of portfolio replication in March 2009**

DATE	STRIKE PRICE(K)													
	230	240	250	260	270	280	290	300	310	320	330	340	350	
2	0	0	0	0	0	0	0	0	1021	292.4	60.4	0	0	
3	0	0	0	0	0	0	0	0	0	261.6	-9.25	0	0	
4	0	0	0	0	0	0	0	0	578.9	168.3	21.6	0	0	
5	0	0	0	0	0	0	0	0	471.4	142.9	-2.13	0	0	
6	0	0	0	0	0	0	0	0	0	173.4	-12.2	0	0	
9	0	0	0	0	0	0	0	0	747.1	114.6	0	0	0	
10	0	0	0	0	0	0	0	0	0	99.8	0	0	0	
11	0	0	0	0	0	0	0	0	315.5	75.12	0	0	0	
12	0	0	0	0	0	0	0	0	292.1	21.72	0	0	0	
13	0	0	0	0	0	0	0	0	0	69.16	0	0	0	
16	0	0	0	0	0	0	0	0	0	26.77	0	0	0	
17	0	0	0	0	0	0	0	0	0	42.06	0	0	0	
18	0	0	0	0	0	0	0	0	0	54.92	0	0	0	
19	0	0	0	0	0	0	0	0	0	80.46	0	0	0	
20	0	0	0	0	0	0	0	0	0	54.45	0	0	0	
23	0	0	0	0	0	0	0	0	0	0	0	0	0	
24	0	0	0	0	0	0	0	0	0	20.66	0	0	0	
25	0	0	0	0	0	0	0	0	0	0	0	0	0	
26	0	0	0	0	0	0	0	0	0	0	0	0	0	
27	0	0	0	0	0	0	0	0	-178.9	0	0	0	0	

Table 20: Profit/Loss of portfolio replication in June 2009

DATE	STRIKE PRICE(K)															
	350	360	370	380	390	400	410	420	430	440	450	460	470	480	490	500
1	0	0	0	0	0	0	0	0	0	0	0	0	-682	0	0	0
2	0	0	0	0	0	0	0	0	0	0	-1111.1	-871.7	-734	0	0	0
3	0	0	0	0	0	0	0	0	0	0	0	0	0	0	0	0
4	0	0	0	0	0	0	0	0	0	0	0	0	0	0	0	0
5	0	0	0	0	0	0	0	0	0	0	0	0	0	0	-316	0
8	0	0	0	0	0	0	0	0	0	0	0	0	0	0	0	0
9	0	0	0	0	0	0	0	0	0	0	0	0	0	0	0	0
10	0	0	0	0	0	0	0	0	0	0	0	0	0	0	0	0
11	0	0	0	0	0	0	0	0	0	0	0	0	0	0	0	0
12	0	0	0	0	0	0	0	0	0	0	0	0	0	0	0	-209
15	0	0	0	0	0	0	0	0	0	0	0	0	0	0	0	0
16	0	0	0	0	0	0	0	0	0	0	0	-223.2	-149	0	0	0
17	0	0	0	0	0	0	0	0	0	0	-111.33	3.585	0	0	0	0
18	0	0	0	0	0	0	0	690.2	0	76.92	89.05	0	0	0	0	0
19	0	0	0	0	0	0	0	0	0	-137	-31.015	47.63	0	0	0	0
22	0	0	0	0	0	0	0	0	0	-189	0	0	0	0	0	0
23	0	0	0	0	0	0	0	0	-468	0	0	0	0	0	0	0
24	0	0	0	0	0	0	0	0	470.8	9.05	0	0	0	0	0	0
25	0	0	0	0	0	0	0	0	0	309.1	0	0	0	0	0	0
26	0	0	449.8	0	0	0	0	0	0	169.1	0	0	0	0	0	0

## APPENDIX E

**Table 21: The difference between real and expected profit in December 2008**

DATE	STRIKE PRICE(K)																
	210	220	230	240	250	260	270	280	290	300	310	320	330	340	350	360	370
4	0	0	0	0	0	338.52	31.84	-564.60	-1227.72	-1313.15	-562.76	-715.61	-288.86	-90.95	-90.95	-90.95	-90.95
8	0	0	0	0	0	0	0	505.42	451.05	157.22	187.53	-635.08	-531.63	-135.34	-90.95	-90.95	-90.95
9	0	0	0	0	0	0	0	0	1528.21	1181.48	927.47	-219.28	-385.56	-111.46	-89.57	-90.95	-90.95
11	0	0	0	0	0	0	0	0	0	1056.60	775.30	-366.76	-485.30	-145.13	-90.60	-90.95	-90.95
12	0	0	0	0	0	0	0	0	1258.62	966.41	714.57	-390.55	-488.86	-128.98	-90.95	-90.95	-90.95
15	0	0	0	0	0	0	0	0	0	0	0	-86.42	-295.63	-73.07	-84.50	-90.95	-90.95
16	0	0	0	0	0	0	0	0	0	0	0	139.60	-217.02	-55.83	-80.45	-90.95	-90.95
17	0	0	0	0	0	0	0	0	0	0	1432.74	0	-218.64	-69.06	-86.14	-90.95	-90.95
18	0	0	0	0	0	0	0	0	0	0	0	586.84	-117.92	-70.44	-86.77	-90.95	-90.95
19	0	0	0	0	0	0	0	0	0	0	1736.83	42.19	-335.99	-145.31	-90.95	-90.95	-90.95
22	0	0	0	0	0	0	0	0	0	0	1499.23	234.98	-90.95	-90.95	-90.95	0	0
23	0	0	0	0	0	0	0	0	0	0	0	297.78	-90.95	-90.95	-90.95	0	0
24	0	0	0	0	0	0	0	0	0	0	0	-9.64	-90.95	-90.95	-90.95	0	0
25	0	0	0	0	0	0	0	0	0	0	0	6.50	-90.95	-90.95	0	0	0
26	0	0	0	0	0	0	0	0	0	0	901.10	-90.95	-90.95	-90.95	0	0	0

**Table 22: The difference between real and expected profit in March 2009**

DATE	STRIKE PRICE(K)													
	230	240	250	260	270	280	290	300	310	320	330	340	350	
2	0	0	0	0	0	0	0	0	918.90	157.41	-47.96	0	0	
3	0	0	0	0	0	0	0	0	0	41.65	-90.77	0	0	
4	0	0	0	0	0	0	0	0	508.46	48.62	-80.65	0	0	
5	0	0	0	0	0	0	0	0	381.71	30.64	-97.88	0	0	
6	0	0	0	0	0	0	0	0	0	42.91	-96.40	0	0	
9	0	0	0	0	0	0	0	0	705.80	54.48	0	0	0	
10	0	0	0	0	0	0	0	0	0	62.62	0	0	0	
11	0	0	0	0	0	0	0	0	291.13	18.95	0	0	0	
12	0	0	0	0	0	0	0	0	267.24	-26.37	0	0	0	
13	0	0	0	0	0	0	0	0	0	24.67	0	0	0	
16	0	0	0	0	0	0	0	0	0	6.20	0	0	0	
17	0	0	0	0	0	0	0	0	0	1.44	0	0	0	
18	0	0	0	0	0	0	0	0	0	18.46	0	0	0	
19	0	0	0	0	0	0	0	0	0	25.43	0	0	0	
20	0	0	0	0	0	0	0	0	0	-9.62	0	0	0	
23	0	0	0	0	0	0	0	0	0	0	0	0	0	
24	0	0	0	0	0	0	0	0	0	-24.27	0	0	0	
25	0	0	0	0	0	0	0	0	0	0	0	0	0	
26	0	0	0	0	0	0	0	0	0	0	0	0	0	
27	0	0	0	0	0	0	0	0	-351.17	0	0	0	0	



**Table 23: The difference between real and expected profit in June 2009**

DATE	STRIKE PRICE(K)															
	350	360	370	380	390	400	410	420	430	440	450	460	470	480	490	500
1	0	0	0	0	0	0	0	0	0	0	0	0	-683.20	0	0	0
2	0	0	0	0	0	0	0	0	0	0	-1273.92	-970.90	-750.12	0	0	0
3	0	0	0	0	0	0	0	0	0	0	0	0	0	0	0	0
4	0	0	0	0	0	0	0	0	0	0	0	0	0	0	0	0
5	0	0	0	0	0	0	0	0	0	0	0	0	0	0	-316.89	0
8	0	0	0	0	0	0	0	0	0	0	0	0	0	0	0	0
9	0	0	0	0	0	0	0	0	0	0	0	0	0	0	0	0
10	0	0	0	0	0	0	0	0	0	0	0	0	0	0	0	0
11	0	0	0	0	0	0	0	0	0	0	0	0	0	0	0	0
12	0	0	0	0	0	0	0	0	0	0	0	0	0	0	0	0
15	0	0	0	0	0	0	0	0	0	0	0	0	0	0	0	0
16	0	0	0	0	0	0	0	0	0	0	0	-312.61	-164.54	0	0	0
17	0	0	0	0	0	0	0	0	0	0	-225.44	-129.50	0	0	0	0
18	0	0	0	0	0	0	0	21.85	0	-239.67	-90.95	0	0	0	0	0
19	0	0	0	0	0	0	0	0	0	-162.37	-108.91	-91.29	0	0	0	0
22	0	0	0	0	0	0	0	0	0	-201.89	0	0	0	0	0	0
23	0	0	0	0	0	0	0	0	-581.44	0	0	0	0	0	0	0
24	0	0	0	0	0	0	0	0	451.71	-90.95	0	0	0	0	0	0
25	0	0	0	0	0	0	0	0	0	-90.95	0	0	0	0	0	0
26	0	0	342.25	0	0	0	0	0	0	-90.95	0	0	0	0	0	0

## APPENDIX F

**Table 24: Total transaction costs in December trading**

DATE	STRIKE PRICE(K)																
	210	220	230	240	250	260	270	280	290	300	310	320	330	340	350	360	370
4	NaN	NaN	NaN	NaN	NaN	133.15	136.15	134.85	137.17	146.79	140.24	64.45	9.67	0.00	5.50E-10	5.50E-10	5.50E-10
8	NaN	NaN	NaN	NaN	NaN	NaN	NaN	135.87	136.60	157.46	177.45	104.04	39.29	9.85	0.00	2.06E-10	2.06E-10
9	NaN	NaN	NaN	NaN	NaN	NaN	NaN	NaN	137.33	156.53	172.44	113.01	57.01	22.96	3.23	0.00	8.96E-11
11	NaN	NaN	NaN	NaN	NaN	NaN	NaN	NaN	NaN	155.97	175.38	119.36	59.72	23.02	2.43	3.89E-11	3.89E-11
12	NaN	NaN	NaN	NaN	NaN	NaN	NaN	NaN	138.07	152.33	168.46	95.25	39.02	9.70	0.00	3.96E-11	3.96E-11
15	NaN	NaN	NaN	NaN	NaN	NaN	NaN	NaN	NaN	NaN	NaN	109.08	54.38	20.03	1.79	1.52E-11	1.52E-11
16	NaN	NaN	NaN	NaN	NaN	NaN	NaN	NaN	NaN	NaN	NaN	113.95	56.42	22.24	3.06	0.00	4.17E-12
17	NaN	NaN	NaN	NaN	NaN	NaN	NaN	NaN	NaN	NaN	175.29	NaN	55.71	20.86	1.86	9.90E-12	9.90E-12
18	NaN	NaN	NaN	NaN	NaN	NaN	NaN	NaN	NaN	NaN	NaN	95.20	56.33	21.13	1.92	3.29E-12	3.29E-12
19	NaN	NaN	NaN	NaN	NaN	NaN	NaN	NaN	NaN	NaN	132.08	81.84	32.34	3.57	2.86E-12	2.86E-12	2.86E-12
22	NaN	NaN	NaN	NaN	NaN	NaN	NaN	NaN	NaN	NaN	119.21	40.40	4.66E-12	4.66E-12	4.66E-12	NaN	NaN
23	NaN	NaN	NaN	NaN	NaN	NaN	NaN	NaN	NaN	NaN	NaN	43.03	1.83E-12	1.83E-12	1.83E-12	NaN	NaN
24	NaN	NaN	NaN	NaN	NaN	NaN	NaN	NaN	NaN	NaN	NaN	15.04	1.11E-12	1.11E-12	1.11E-12	NaN	NaN
25	NaN	NaN	NaN	NaN	NaN	NaN	NaN	NaN	NaN	NaN	NaN	12.96	3.71E-13	3.71E-13	NaN	NaN	NaN
26	NaN	NaN	NaN	NaN	NaN	NaN	NaN	NaN	NaN	NaN	57.94	3.57E-13	3.57E-13	3.57E-13	NaN	NaN	NaN

**Table 25: Total transaction costs in March trading**

DATE	STRIKE PRICE(K)													
	230	240	250	260	270	280	290	300	310	320	330	340	350	
2	NaN	NaN	NaN	NaN	NaN	NaN	NaN	NaN	NaN	117	50.33	10.69	NaN	NaN
3	NaN	NaN	NaN	NaN	NaN	NaN	NaN	NaN	NaN	NaN	45.34	9.82	NaN	NaN
4	NaN	NaN	NaN	NaN	NaN	NaN	NaN	NaN	NaN	118	52.97	9.40	NaN	NaN
5	NaN	NaN	NaN	NaN	NaN	NaN	NaN	NaN	NaN	109	46.13	8.83	NaN	NaN
6	NaN	NaN	NaN	NaN	NaN	NaN	NaN	NaN	NaN	NaN	50.16	19.13	NaN	NaN
9	NaN	NaN	NaN	NaN	NaN	NaN	NaN	NaN	NaN	95.5	37.24	NaN	NaN	NaN
10	NaN	NaN	NaN	NaN	NaN	NaN	NaN	NaN	NaN	NaN	35.91	NaN	NaN	NaN
11	NaN	NaN	NaN	NaN	NaN	NaN	NaN	NaN	NaN	87.2	31.72	NaN	NaN	NaN
12	NaN	NaN	NaN	NaN	NaN	NaN	NaN	NaN	NaN	94.8	37.56	NaN	NaN	NaN
13	NaN	NaN	NaN	NaN	NaN	NaN	NaN	NaN	NaN	NaN	35.82	NaN	NaN	NaN
16	NaN	NaN	NaN	NaN	NaN	NaN	NaN	NaN	NaN	NaN	36.85	NaN	NaN	NaN
17	NaN	NaN	NaN	NaN	NaN	NaN	NaN	NaN	NaN	NaN	30.37	NaN	NaN	NaN
18	NaN	NaN	NaN	NaN	NaN	NaN	NaN	NaN	NaN	NaN	24.25	NaN	NaN	NaN
19	NaN	NaN	NaN	NaN	NaN	NaN	NaN	NaN	NaN	NaN	23.50	NaN	NaN	NaN
20	NaN	NaN	NaN	NaN	NaN	NaN	NaN	NaN	NaN	NaN	12.53	NaN	NaN	NaN
23	NaN	NaN	NaN	NaN	NaN	NaN	NaN	NaN	NaN	NaN	NaN	NaN	NaN	NaN
24	NaN	NaN	NaN	NaN	NaN	NaN	NaN	NaN	NaN	NaN	11.5	NaN	NaN	NaN
25	NaN	NaN	NaN	NaN	NaN	NaN	NaN	NaN	NaN	NaN	NaN	NaN	NaN	NaN
26	NaN	NaN	NaN	NaN	NaN	NaN	NaN	NaN	NaN	NaN	NaN	NaN	NaN	NaN
27	NaN	NaN	NaN	NaN	NaN	NaN	NaN	NaN	NaN	35.97	NaN	NaN	NaN	NaN

**Table 26: Total transaction costs in June trading**

DATE	STRIKE PRICE(K)															
	350	360	370	380	390	400	410	420	430	440	450	460	470	480	490	500
<b>1</b>	NaN	NaN	NaN	NaN	NaN	NaN	NaN	NaN	NaN	NaN	NaN	NaN	89	NaN	NaN	NaN
<b>2</b>	NaN	NaN	NaN	NaN	NaN	NaN	NaN	NaN	NaN	NaN	153.32	108.62	79	NaN	NaN	NaN
<b>3</b>	NaN	NaN	NaN	NaN	NaN	NaN	NaN	NaN	NaN	NaN	NaN	NaN	NaN	NaN	NaN	NaN
<b>4</b>	NaN	NaN	NaN	NaN	NaN	NaN	NaN	NaN	NaN	NaN	NaN	NaN	NaN	NaN	NaN	NaN
<b>5</b>	NaN	NaN	NaN	NaN	NaN	NaN	NaN	NaN	NaN	NaN	NaN	NaN	NaN	NaN	31	NaN
<b>8</b>	NaN	NaN	NaN	NaN	NaN	NaN	NaN	NaN	NaN	NaN	NaN	NaN	NaN	NaN	NaN	NaN
<b>9</b>	NaN	NaN	NaN	NaN	NaN	NaN	NaN	NaN	NaN	NaN	NaN	NaN	NaN	NaN	NaN	NaN
<b>10</b>	NaN	NaN	NaN	NaN	NaN	NaN	NaN	NaN	NaN	NaN	NaN	NaN	NaN	NaN	NaN	NaN
<b>11</b>	NaN	NaN	NaN	NaN	NaN	NaN	NaN	NaN	NaN	NaN	NaN	NaN	NaN	NaN	NaN	NaN
<b>12</b>	NaN	NaN	NaN	NaN	NaN	NaN	NaN	NaN	NaN	NaN	NaN	NaN	NaN	NaN	NaN	12
<b>15</b>	NaN	NaN	NaN	NaN	NaN	NaN	NaN	NaN	NaN	NaN	NaN	NaN	NaN	NaN	NaN	NaN
<b>16</b>	NaN	NaN	NaN	NaN	NaN	NaN	NaN	NaN	NaN	NaN	NaN	26.78	9.3	NaN	NaN	NaN
<b>17</b>	NaN	NaN	NaN	NaN	NaN	NaN	NaN	NaN	NaN	NaN	34.34	5.90	NaN	NaN	NaN	NaN
<b>18</b>	NaN	NaN	NaN	NaN	NaN	NaN	NaN	218.09	NaN	19.03	0.00	NaN	NaN	NaN	NaN	NaN
<b>19</b>	NaN	NaN	NaN	NaN	NaN	NaN	NaN	NaN	NaN	54.35	18.26	0.14	NaN	NaN	NaN	NaN
<b>22</b>	NaN	NaN	NaN	NaN	NaN	NaN	NaN	NaN	NaN	20.45	NaN	NaN	NaN	NaN	NaN	NaN
<b>23</b>	NaN	NaN	NaN	NaN	NaN	NaN	NaN	NaN	19.76	NaN	NaN	NaN	NaN	NaN	NaN	NaN
<b>24</b>	NaN	NaN	NaN	NaN	NaN	NaN	NaN	NaN	77.7	1.00E-12	NaN	NaN	NaN	NaN	NaN	NaN
<b>25</b>	NaN	NaN	NaN	NaN	NaN	NaN	NaN	NaN	NaN	2.94E-13	NaN	NaN	NaN	NaN	NaN	NaN
<b>26</b>	NaN	NaN	78.30	NaN	NaN	NaN	NaN	NaN	NaN	1.38E-13	NaN	NaN	NaN	NaN	NaN	NaN

ศูนย์วิทยทรัพยากร  
จุฬาลงกรณ์มหาวิทยาลัย

**Table 27: Total liquidity costs in December**

DATE	STRIKE PRICE(K)																
	210	220	230	240	250	260	270	280	290	300	310	320	330	340	350	360	370
<b>4</b>	NaN	NaN	NaN	NaN	NaN	206.58	214.83	213.23	214.60	228.57	222.46	114.38	21.37	0.00	9.41E-10	9.41E-10	9.41E-10
<b>8</b>	NaN	NaN	NaN	NaN	NaN	NaN	NaN	210.08	213.51	257.47	302.84	200.18	82.89	16.74	0.00	3.89E-10	3.89E-10
<b>9</b>	NaN	NaN	NaN	NaN	NaN	NaN	NaN	NaN	219.68	249.04	288.15	209.31	109.50	36.70	4.73	0.00	1.97E-10
<b>11</b>	NaN	NaN	NaN	NaN	NaN	NaN	NaN	NaN	NaN	302.87	329.82	237.60	120.58	38.20	3.57	6.17E-11	6.17E-11
<b>12</b>	NaN	NaN	NaN	NaN	NaN	NaN	NaN	NaN	204.58	235.19	275.00	177.02	80.96	16.26	0.00	5.82E-11	5.82E-11
<b>15</b>	NaN	NaN	NaN	NaN	NaN	NaN	NaN	NaN	NaN	NaN	NaN	202.62	103.81	31.48	2.58	2.23E-11	2.23E-11
<b>16</b>	NaN	NaN	NaN	NaN	NaN	NaN	NaN	NaN	NaN	NaN	NaN	208.99	107.86	35.25	4.39	0.00	6.44E-12
<b>17</b>	NaN	NaN	NaN	NaN	NaN	NaN	NaN	NaN	NaN	NaN	288.52	NaN	106.30	32.99	2.66	1.46E-11	1.46E-11
<b>18</b>	NaN	NaN	NaN	NaN	NaN	NaN	NaN	NaN	NaN	NaN	NaN	154.08	99.70	33.32	2.74	4.85E-12	4.85E-12
<b>19</b>	NaN	NaN	NaN	NaN	NaN	NaN	NaN	NaN	NaN	NaN	195.90	135.43	61.14	7.83	6.05E-12	6.05E-12	6.05E-12
<b>22</b>	NaN	NaN	NaN	NaN	NaN	NaN	NaN	NaN	NaN	NaN	229.16	75.26	7.11E-12	7.11E-12	7.11E-12	NaN	NaN
<b>23</b>	NaN	NaN	NaN	NaN	NaN	NaN	NaN	NaN	NaN	NaN	NaN	63.05	2.68E-12	2.68E-12	2.68E-12	NaN	NaN
<b>24</b>	NaN	NaN	NaN	NaN	NaN	NaN	NaN	NaN	NaN	NaN	NaN	21.94	1.61E-12	1.61E-12	1.61E-12	NaN	NaN
<b>25</b>	NaN	NaN	NaN	NaN	NaN	NaN	NaN	NaN	NaN	NaN	NaN	18.86	5.39E-13	5.39E-13	NaN	NaN	NaN
<b>26</b>	NaN	NaN	NaN	NaN	NaN	NaN	NaN	NaN	NaN	NaN	84.21	5.18E-13	5.18E-13	5.18E-13	NaN	NaN	NaN

**Table 28: Total liquidity costs in March**

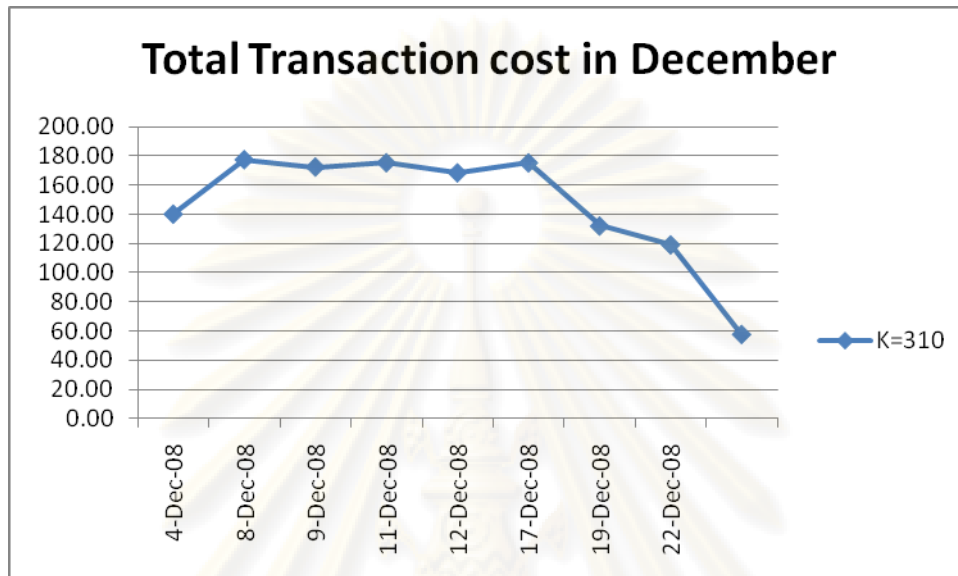
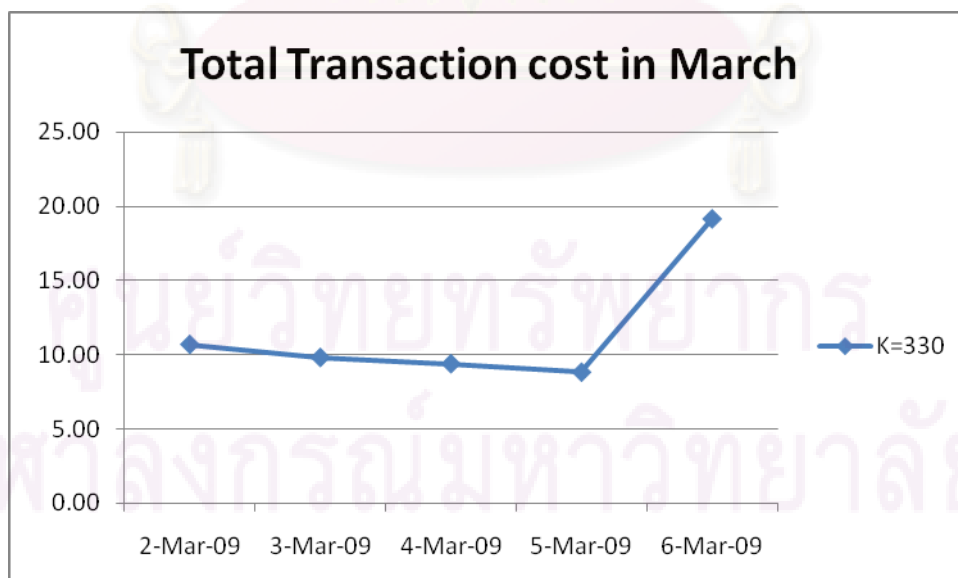
DATE	STRIKE PRICE(K)												
	230	240	250	260	270	280	290	300	310	320	330	340	350
2	NaN	NaN	NaN	NaN	NaN	NaN	NaN	NaN	191	82.96	18.40	NaN	NaN
3	NaN	NaN	NaN	NaN	NaN	NaN	NaN	NaN	NaN	76.76	18.71	NaN	NaN
4	NaN	NaN	NaN	NaN	NaN	NaN	NaN	NaN	191	87.58	17.93	NaN	NaN
5	NaN	NaN	NaN	NaN	NaN	NaN	NaN	NaN	217	93.96	21.59	NaN	NaN
6	NaN	NaN	NaN	NaN	NaN	NaN	NaN	NaN	NaN	79.67	30.34	NaN	NaN
9	NaN	NaN	NaN	NaN	NaN	NaN	NaN	NaN	154	60.81	NaN	NaN	NaN
10	NaN	NaN	NaN	NaN	NaN	NaN	NaN	NaN	NaN	58.53	NaN	NaN	NaN
11	NaN	NaN	NaN	NaN	NaN	NaN	NaN	NaN	151	53.75	NaN	NaN	NaN
12	NaN	NaN	NaN	NaN	NaN	NaN	NaN	NaN	161	61.18	NaN	NaN	NaN
13	NaN	NaN	NaN	NaN	NaN	NaN	NaN	NaN	NaN	57.35	NaN	NaN	NaN
16	NaN	NaN	NaN	NaN	NaN	NaN	NaN	NaN	NaN	55.61	NaN	NaN	NaN
17	NaN	NaN	NaN	NaN	NaN	NaN	NaN	NaN	NaN	45.85	NaN	NaN	NaN
18	NaN	NaN	NaN	NaN	NaN	NaN	NaN	NaN	NaN	43.16	NaN	NaN	NaN
19	NaN	NaN	NaN	NaN	NaN	NaN	NaN	NaN	NaN	34.66	NaN	NaN	NaN
20	NaN	NaN	NaN	NaN	NaN	NaN	NaN	NaN	NaN	18.47	NaN	NaN	NaN
23	NaN	NaN	NaN	NaN	NaN	NaN	NaN	NaN	NaN	NaN	NaN	NaN	NaN
24	NaN	NaN	NaN	NaN	NaN	NaN	NaN	NaN	NaN	16.89	NaN	NaN	NaN
25	NaN	NaN	NaN	NaN	NaN	NaN	NaN	NaN	NaN	NaN	NaN	NaN	NaN
26	NaN	NaN	NaN	NaN	NaN	NaN	NaN	NaN	NaN	NaN	NaN	NaN	NaN
27	NaN	NaN	NaN	NaN	NaN	NaN	NaN	NaN	53.20	NaN	NaN	NaN	NaN

**Table 29: Total liquidity costs in June**

DATE	STRIKE PRICE(K)															
	350	360	370	380	390	400	410	420	430	440	450	460	470	480	490	500
1	NaN	NaN	NaN	NaN	NaN	NaN	NaN	NaN	NaN	NaN	NaN	NaN	101	NaN	NaN	NaN
2	NaN	NaN	NaN	NaN	NaN	NaN	NaN	NaN	NaN	NaN	172.78	121.50	87	NaN	NaN	NaN
3	NaN	NaN	NaN	NaN	NaN	NaN	NaN	NaN	NaN	NaN	NaN	NaN	NaN	NaN	NaN	NaN
4	NaN	NaN	NaN	NaN	NaN	NaN	NaN	NaN	NaN	NaN	NaN	NaN	NaN	NaN	NaN	NaN
5	NaN	NaN	NaN	NaN	NaN	NaN	NaN	NaN	NaN	NaN	NaN	NaN	NaN	NaN	37	NaN
8	NaN	NaN	NaN	NaN	NaN	NaN	NaN	NaN	NaN	NaN	NaN	NaN	NaN	NaN	NaN	NaN
9	NaN	NaN	NaN	NaN	NaN	NaN	NaN	NaN	NaN	NaN	NaN	NaN	NaN	NaN	NaN	NaN
10	NaN	NaN	NaN	NaN	NaN	NaN	NaN	NaN	NaN	NaN	NaN	NaN	NaN	NaN	NaN	NaN
11	NaN	NaN	NaN	NaN	NaN	NaN	NaN	NaN	NaN	NaN	NaN	NaN	NaN	NaN	NaN	NaN
12	NaN	NaN	NaN	NaN	NaN	NaN	NaN	NaN	NaN	NaN	NaN	NaN	NaN	NaN	NaN	12
15	NaN	NaN	NaN	NaN	NaN	NaN	NaN	NaN	NaN	NaN	NaN	NaN	NaN	NaN	NaN	NaN
16	NaN	NaN	NaN	NaN	NaN	NaN	NaN	NaN	NaN	NaN	NaN	29.49	10	NaN	NaN	NaN
17	NaN	NaN	NaN	NaN	NaN	NaN	NaN	NaN	NaN	NaN	38.38	6.65	NaN	NaN	NaN	NaN
18	NaN	NaN	NaN	NaN	NaN	NaN	NaN	241.54	NaN	21.59	0.00	NaN	NaN	NaN	NaN	NaN
19	NaN	NaN	NaN	NaN	NaN	NaN	NaN	NaN	NaN	60.4758	20.23	0.16	NaN	NaN	NaN	NaN
22	NaN	NaN	NaN	NaN	NaN	NaN	NaN	NaN	NaN	23.1402	NaN	NaN	NaN	NaN	NaN	NaN
23	NaN	NaN	NaN	NaN	NaN	NaN	NaN	NaN	21.43	NaN	NaN	NaN	NaN	NaN	NaN	NaN
24	NaN	NaN	NaN	NaN	NaN	NaN	NaN	NaN	84.21	1.10E-12	NaN	NaN	NaN	NaN	NaN	NaN
25	NaN	NaN	NaN	NaN	NaN	NaN	NaN	NaN	NaN	3.19E-13	NaN	NaN	NaN	NaN	NaN	NaN
26	NaN	NaN	84.21	NaN	NaN	NaN	NaN	NaN	NaN	1.48E-13	NaN	NaN	NaN	NaN	NaN	NaN

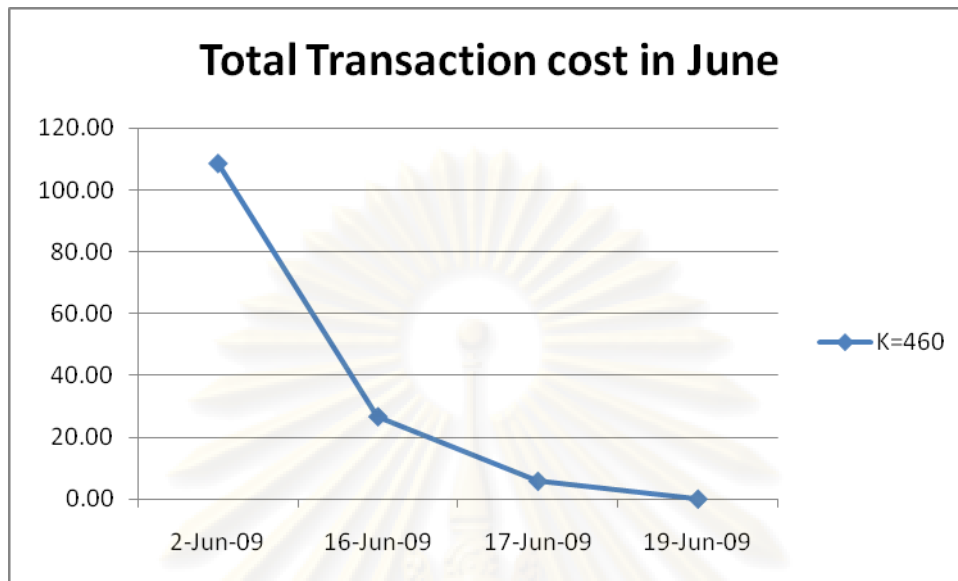
ศูนย์วิทยทรัพยากร  
จุฬาลงกรณ์มหาวิทยาลัย

## APPENDIX G

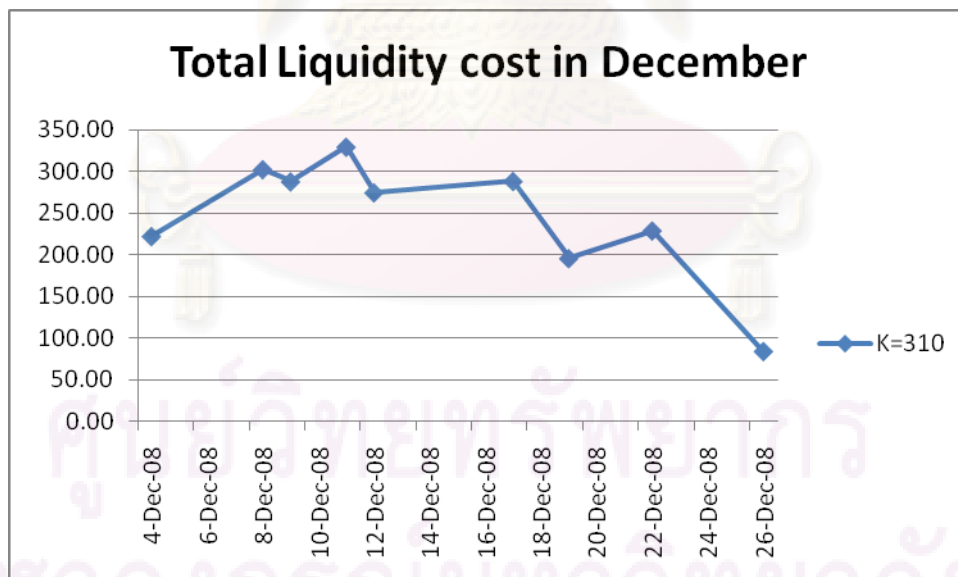
**Figure 54: Total transaction costs in December with strike price=310****Figure 55: Total transaction costs in March with strike price=330**



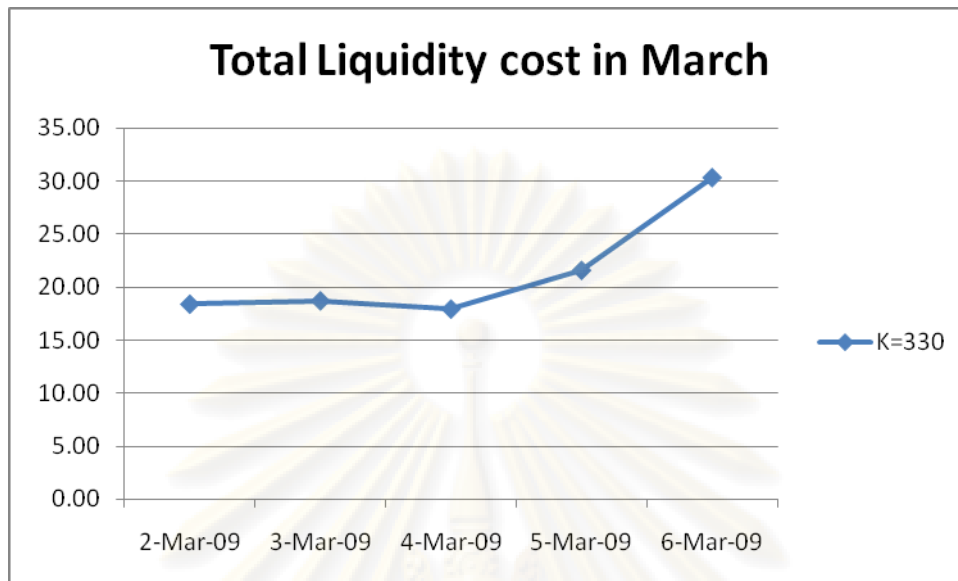
**Figure 56: Total transaction costs in June with strike price=460**



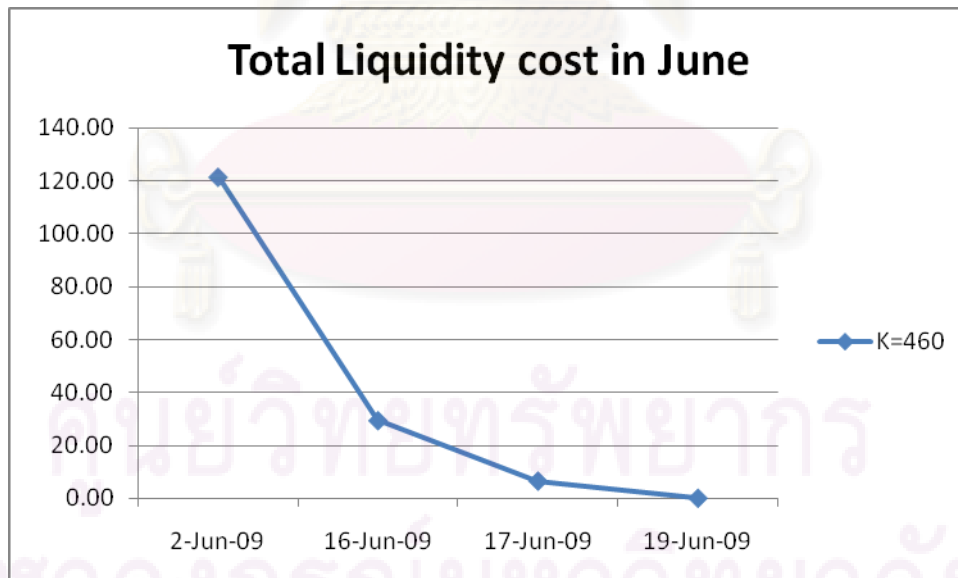
**Figure 57: Total liquidity costs in December with strike price=310**



**Figure 58: Total liquidity costs in March with strike price=330**



**Figure 59: Total liquidity costs in June with strike price=460**



## APPENDIX H

### Main binomial tree option pricing code

```
function [TotalPrice,ff,yy,xx] =
MainBT_CRR(alpha,theta,sigma,strike,input,N)

[row, column] = size(input);
rowK = size(strike,1);

for i=1:row-1

    S0 = input(i,1);
    display(['current Stock price = ', num2str(S0)]);
    numPeriods = row-i; %numPeriods = time to maturity (days)
    for j=1:rowK

        Tree = TreeGeneration_CRR(S0,numPeriods,sigma,N);
        [f,y,x] =
Minimization_arbitrage_jik(Tree,alpha,theta,strike(j),N);

        ff{i,j}=f;
        yy{i,j}=y;
        xx{i,j}=x;
        TotalPrice(i,j) = f(1,1);
    end
end

end
```

ศูนย์วิทยทรัพยากร  
จุฬาลงกรณ์มหาวิทยาลัย

### Multi-periods of binomial tree construction code

```
function Tree = TreeGeneration_CRR(S0,numPeriods,sigma,N)

Tree(1,1) = S0;
dt = 1/(N*260);

up = exp(sigma*sqrt(dt));    %Cox-Ross tree
down = exp(- sigma*sqrt(dt)); %Cox-Ross tree

for i=2:numPeriods*N+1
    power = i-1;

    for j=1:i
        Tree(j,i) = (up^power)*(down^(i-1-power))*S0;
        power = power -1;
    end
end
end
```



ศูนย์วิทยทรัพยากร  
จุฬาลงกรณ์มหาวิทยาลัย

### Minimization of super replicating portfolio code

```

function [f,y,x] = Minimization_arbitrage_jik(Tree,alpha,theta,strike,N)
% y: money market account
% x: number of shares of underlying
% f: call price

totalLevel = size(Tree,2); % totalLevel = m*N+1 , m = number of days(eg.
                          50days*15steps/day = 750steps)

%options = optimset('TolCon',1e-006);
%options = optimset('display','off','TolFun',10^(-6),'TolX',10^(-6));
options = optimset('display','off');
for i=totalLevel-N:-N:1 % i = i^th stage in the tree (column), N =
                      frequency per day

    currentPrice = (Tree(:,i))';
    futurePrice = (Tree(:,i+N))';
    node = i; % node represents the number of nodes at the current
              tree level

    for j=1:node % j = j^th scenario at stage i (row)

        S = currentPrice(j);
        Sfuture = futurePrice(j:j+N);

        if j==1
            z0 = [0;1];
        else
            z0 = [z(1);z(2)];
        end
        clear z;
        if(i==totalLevel-N)
            %x = fmincon(@myfun,x0,A,b,Aeq,beq,lb,ub,@mycon);
            [z,fval] = fmincon(@(z) MinFunction(z,S),z0,[],[],[],[], [],[],@(z)
[],[],@(z) ConstraintT(z,Sfuture,alpha,theta,strike,S,N),options);
        elseif (i==1)
            xfuture = x(j:j+N,i+N);
            yfuture = y(j:j+N,i+N);
            [z,fval,exitflag,output] = fmincon(@(z)
MinFunctionI(z,S,alpha,theta),z0,[],[],[],[], [],[],@(z)
Constraint(z,yfuture,xfuture,Sfuture,alpha,theta,S,N),options);
        else
            xfuture = x(j:j+N,i+N);
            yfuture = y(j:j+N,i+N);
            [z,fval,exitflag,output] = fmincon(@(z)
MinFunction(z,S),z0,[],[],[],[], [],[],@(z)
Constraint(z,yfuture,xfuture,Sfuture,alpha,theta,S,N),options);
        end

        y(j,i) = z(1);
        x(j,i) = z(2);
        f(j,i) = fval;
    end
end
end
end

```

```

function f = MinFunction(z,S)
f = z(1) + (z(2)*S); %z(1) = yt, z(2) = xt
end

function f = MinFunctionI(z,S,alpha,theta)
if theta > 0
    f = z(1) + (z(2)*S) + ((z(2)^2)*alpha)*S + (abs(z(2))*theta)*S;
else
    f = z(1) + (z(2)*S) + ((z(2)^2)*alpha)*S;
end
end

function [c,ceq]= Constraint(z,yfuture,xfuture,Sfuture,alpha,theta,S,N)
for k = 1:N+1
    if theta > 0
        c(k) = (yfuture(k) + (xfuture(k)*Sfuture(k)) +
(alpha*Sfuture(k)*((xfuture(k)-z(2))^2)) +
(theta*Sfuture(k)*(abs(xfuture(k)-z(2))))) - (z(1) + z(2)*Sfuture(k));
    else
        c(k) = (yfuture(k) + (xfuture(k)*Sfuture(k)) +
(alpha*Sfuture(k)*((xfuture(k)-z(2))^2))) - (z(1) + z(2)*Sfuture(k));
    end
    c(N+2) = -z(1) - (z(2)*S);
    ceq = [];
end
end

function [c,ceq]= ConstraintT(z,Sfuture,alpha,theta,strike,S,N)
for k = 1:N+1
    if theta > 0
        c(k) = (200*max(0,Sfuture(k)-strike) + (alpha*Sfuture(k)*((0-
z(2))^2)) + (theta*Sfuture(k)*(abs(0-z(2))))) - (z(1) +
(z(2)*Sfuture(k)));
    else
        c(k) = (200*max(0,Sfuture(k)-strike) + (alpha*Sfuture(k)*((0-
z(2))^2))) - (z(1) + (z(2)*Sfuture(k)));
    end
    c(N+2) = -z(1) - (z(2)*S);
    ceq = [];
end
end

```

### Arbitrage trading strategy code

```

function
[xnewAll,LcostAll,TcostAll,DiffAll,yAll,profitAll>TotalLcostAll>TotalTco
stAll>TotalDiffAll] =
Main_Test_newnew(y0all,xall,theta,strikeall,inputall,N,optionTcost)

%Tree = a multiperiod binomial Tree of SET50
%y0 = revenue from selling the option
xnewAll = {};
LcostAll = {};
TcostAll = {};
DiffAll = {};
yAll = {};
profitAll = {};
TotalLcostAll= [];
TotalTcostAll= [];
TotalDiffAll = [];

Numdate = size(inputall,1)-1; %number of days
NumK = size(strikeall,1); %number of strike price

for i_date=1:Numdate

    for i_K= 1:NumK
        y0 = y0all(i_date,i_K);
        if y0==0
            xnew = [];
            Lcost = [];
            Tcost = [];
            Diff = [];
            y = [];
            profit = [];
            TotalLcost = NaN;
            TotalTcost = NaN;
            TotalDiff = NaN;
        else

            x = xall{i_date,i_K};
            strike = strikeall(i_K);
            input = inputall(i_date:end,:);

            T = size(input,1);
            xnew = [];
            deltax = [];
            Lcost = [];
            Tcost = [];
            Diff = [];
            y = [];

            S0 = input(1,1);
            numPeriods = T-1;
            Tree = TreeGeneration_jik(S0,numPeriods,N);
            ModelPrice = Tree;
            MktPrice = (input(:,1));
            BidPrice = 100*(input(:,2));
            AskPrice = 100*(input(:,3));
            TDEX = 100*(input(:,4));
        end
    end
end

```

```

for j=1:T % i = column , T = maturity date, liquidate stock
           so that xnew = 0 on maturity date

node = 1+N*(j-1);

if (j==1) % at the first trading day
    xold = 0;
    xnew(j) = x(1,1);
    deltax(j) = xnew(j) - xold;
elseif (j==T) % at the last day of trade(Maturity date)
    xold = xnew(j-1);
    xnew(j) = 0;
    deltax(j) = xnew(j) - xold;
else
    xold = xnew(j-1);
    [MinDiff,point] = min(abs(MktPrice(j)-
ModelPrice(1:node,node)));
    xnew(j) = x(point,node);
    deltax(j) = xnew(j) - xold;
end

if (deltax(j) >= 0) %buying more stock
    Tcost(j) = theta*abs(deltax(j))*AskPrice(j);
    inflow(j) = 0;
    outflow(j) = abs(deltax(j))*AskPrice(j);
else % selling stock
    Tcost(j) = theta*abs(deltax(j))*BidPrice(j);
    inflow(j) = abs(deltax(j))*BidPrice(j);
    outflow(j) = 0;
end

Lcost(j) = 0.5*(AskPrice(j)-BidPrice(j))*abs(deltax(j));
Diff(j) = deltax(j)*(TDEX(j)-MktPrice(j));

if (j==1)
    y(j) = y0 + inflow(j) - outflow(j) - Tcost(j);
else
    y(j) = y(j-1)+ inflow(j) - outflow(j) - Tcost(j);
end
end
yEnd = y(T);
OptionPayoff = 200*max(0,MktPrice(T)-strike);
profit = yEnd - OptionPayoff - optionTcost;
TotalLcost = sum(Lcost,2);
TotalTcost = sum(Tcost,2);
TotalDiff = sum(Diff,2);

end

```



```
xnewAll{i_date,i_K} = xnew;  
TotalLcostAll(i_date,i_K)= TotalLcost;  
TotalTcostAll(i_date,i_K)= TotalTcost;  
TotalDiffAll(i_date,i_K) = TotalDiff;  
LcostAll{i_date,i_K} = Lcost;  
TcostAll{i_date,i_K} = Tcost;  
DiffAll{i_date,i_K} = Diff;  
yAll{i_date,i_K} = y;  
profitAll{i_date,i_K} = profit;  
end  
end  
end
```



ศูนย์วิทยทรัพยากร  
จุฬาลงกรณ์มหาวิทยาลัย

## BIOGRAPHY

Kornkanok Atisutapote is a Master's degree student majoring in Finance at the Faculty of Commerce and Accountancy, Chulalongkorn University. She was born on 9 February 1984 in Phangnga Thailand. She lives with her sister in Nontaburi Thailand. She holds a Bachelor's degree majoring in Monetary Economics from the Faculty of Economics, Chulalongkorn University.



ศูนย์วิทยทรัพยากร  
จุฬาลงกรณ์มหาวิทยาลัย