

การผลิตสารไตรอะซิไดนจากกลีเซอรอลโดยใช้หอกลิ้นแบบมีปฏิกิริยา

นางสาวพิมพ์ภัทรา สิริชาญสกุลชัย

วิทยานิพนธ์นี้เป็นส่วนหนึ่งของการศึกษาตามหลักสูตรปริญญาวิศวกรรมศาสตรมหาบัณฑิต
สาขาวิชาวิศวกรรมเคมี ภาควิชาวิศวกรรมเคมี
คณะวิศวกรรมศาสตร์ จุฬาลงกรณ์มหาวิทยาลัย
ปีการศึกษา 2554
ลิขสิทธิ์ของจุฬาลงกรณ์มหาวิทยาลัย

บทคัดย่อและแฟ้มข้อมูลฉบับเต็มของวิทยานิพนธ์ตั้งแต่ปีการศึกษา 2554 ที่ให้บริการในคลังปัญญาจุฬาฯ (CUIR)
เป็นแฟ้มข้อมูลของนิสิตเจ้าของวิทยานิพนธ์ที่ส่งผ่านทางบัณฑิตวิทยาลัย

The abstract and full text of theses from the academic year 2011 in Chulalongkorn University Intellectual Repository(CUIR)
are the thesis authors' files submitted through the Graduate School.

PRODUCTION OF TRIACETIN FROM GLYCEROL USING REACTIVE
DISTILLATION

Miss Pimpatthar Siricharnsakunchai

A Thesis Submitted in Partial Fulfillment of the Requirements
for the Degree of Master of Engineering Program in Chemical Engineering
Department of Chemical Engineering
Faculty of Engineering
Chulalongkorn University
Academic Year 2011
Copyright of Chulalongkorn University

Thesis Title PRODUCTION OF TRIACETIN FROM GLYCEROL
 USING REACTIVE DISTILLATION
By Miss Pimpatthar Siricharnsakunchai
Field of Study Chemical Engineering
Thesis Advisor Assistant Professor Amornchai Arpornwichanop, D.Eng.

Accepted by the Faculty of Engineering, Chulalongkorn University in Partial
Fulfillment of the Requirements for the Master's Degree

..... Dean of the Faculty of Engineering
(Associate Professor Boonsom Lerdhirunwong, Dr.Eng.)

THESIS COMMITTEE

..... Chairman
(Associate Professor Muenduen Phisalaphong, Ph.D.)
..... Thesis Advisor
(Assistant Professor Amornchai Arpornwichanop, D.Eng.)
..... Examiner
(Assistant Professor Soorathep Kheawhom, Ph.D.)
..... External Examiner
(Woranee Paengjuntuek, D.Eng.)

พิมพ์ภัทรา สิริชาณูสกุลชัย : การผลิตสารไตรอะซีตินจากกลีเซอรอลโดยใช้หอกลิ้นแบบมีปฏิกิริยา. (PRODUCTION OF TRIACETIN FROM GLYCEROL USING REACTIVE DISTILLATION) อ. ที่ปรึกษาวิทยานิพนธ์หลัก: ผศ. ดร. อมรชัย อภรณ์วิชานพ, 98 หน้า.

กระบวนการผลิตไบโอดีเซลโดยทั่วไปจะได้กลีเซอรอลเป็นผลิตภัณฑ์ร่วม เมื่อความต้องการและการผลิตไบโอดีเซลเพิ่มขึ้นส่งผลให้กลีเซอรอลมีปริมาณเพิ่มมากขึ้นไปด้วย การนำกลีเซอรอลดิบไปใช้ประโยชน์อย่างมีประสิทธิภาพจะนำไปสู่ผลประโยชน์ทางเศรษฐกิจและสิ่งแวดล้อมที่สำคัญ ดังนั้นการผลิตสารไตรอะซีตินซึ่งเป็นสารเคมีสำคัญที่ใช้ในอุตสาหกรรมต่างๆ อาจเป็นทางเลือกที่น่าสนใจในการเพิ่มมูลค่าของกลีเซอรอลดิบ งานวิจัยนี้มีวัตถุประสงค์ในการศึกษาปฏิกิริยาเอสเทอร์ริฟิเคชันของกลีเซอรอลกับกรดอะซีติกเพื่อผลิตสารไตรอะซีติน เนื่องจากโดยธรรมชาติของปฏิกิริยาเอสเทอร์ริฟิเคชันถูกจำกัดด้วยสมดุลเคมีการกลั่นแบบมีปฏิกิริยาซึ่งเกิดปฏิกิริยาเคมีและการกลั่นในเวลาเดียวกันจึงถูกนำมาใช้ในการปรับปรุงการผลิตสารไตรอะซีติน งานวิจัยนี้ได้แบ่งออกเป็น 3 ส่วนในส่วนแรกจะทำการศึกษารามิเตอร์ต่างๆที่มีผลต่อประสิทธิภาพในการผลิตสารไตรอะซีติน ผลที่ได้จากการจำลองกระบวนการแสดงให้เห็นว่าเมื่อกลีเซอรอลและกรดอะซีติกถูกป้อนเข้าสู่หอกลิ้นแบบมีปฏิกิริยาที่อุณหภูมิ 25 °C และป้อนกรดอะซีติกที่ปริมาณมากเกินไปเป็นหกเท่าของปริมาณกลีเซอรอล ค่าการเปลี่ยนของกลีเซอรอลที่ได้เท่ากับ 99.9% และความบริสุทธิ์ของไตรอะซีตินมีค่าเท่ากับ 99.9% จากการวิเคราะห์ค่าใช้จ่ายรวมต่อปีพบว่าโครงสร้างหอกลิ้นแบบมีปฏิกิริยาที่เหมาะสมคือมีจำนวนชั้นการเกิดปฏิกิริยาเท่ากับ 26 ในส่วนที่สองเป็นการศึกษาการออกแบบการกลั่นแบบมีปฏิกิริยาร่วมกับการใช้หอกลิ้นแบบคู่ควบทางความร้อน พลังงานที่ใช้ในการผลิตสารไตรอะซีตินในรูปแบบนี้จะถูกเปรียบเทียบกับการกลั่นแบบมีปฏิกิริยาดั้งเดิมผลที่ได้แสดงให้เห็นว่าสามารถประหยัดพลังงานได้ถึงประมาณ 48.6% สำหรับการศึกษาในส่วนสุดท้ายเป็นการศึกษาผลของกลีเซอรอลดิบที่มีปริมาณของเมทานอลที่แตกต่างกันในการผลิตสารไตรอะซีติน จากผลการศึกษาพบว่าเมื่อปริมาณของเมทานอลเพิ่มขึ้นจะทำให้ความบริสุทธิ์ของสารไตรอะซีตินที่ด้านล่างของหอกลิ้นแบบมีปฏิกิริยาลดลง นอกจากนี้สัดส่วนโมลของน้ำที่ด้านบนของหอกลิ้นยังลดลงอีกด้วยอย่างไรก็ตามค่าการเปลี่ยนของกลีเซอรอลและค่าผลิตผลที่ได้ของผลิตภัณฑ์ลดลงเพียงเล็กน้อยเมื่อเปรียบเทียบกับการใช้สารตั้งต้นเป็นกลีเซอรอลบริสุทธิ์

ภาควิชา _____ วิศวกรรมเคมี _____ ลายมือชื่อนิติดี.....
 สาขาวิชา _____ วิศวกรรมเคมี _____ ลายมือชื่อ อ.ที่ปรึกษาวิทยานิพนธ์หลัก.....
 ปีการศึกษา _____ 2554 _____

5270421621 : MAJOR CHEMICAL ENGINEERING

KEYWORDS : TRIACETIN / REACTIVE DISTILLATION / SIMULATION /
THERMAL COUPLING / CRUDE GLYCEROL

PIMPATTHAR SIRICHARNSAKUNCHAI: PRODUCTION OF
TRICETIN FROM GLYCEROL USING REACTIVE DISTILLATION
ADVISOR: ASST. PROF. AMORNCHAI ARPORNWICHANOP,
D.Eng., 98 pp.

In a conventional process of biodiesel production, glycerol is obtained as by-product. Increases in demand and production of biodiesel enlarge the amount of glycerol generated. Efficient utilization of crude glycerol could lead to significant economic and environmental benefits. The production of triacetin, which is an important chemical used in various applications, might be of potential interest to add value of crude glycerol. The purpose of this work is to study the esterification of glycerol with acetic acid to produce triacetin. Due to the nature of the equilibrium-limited esterification reaction, a reactive distillation in which chemical reaction and separation are carried out at the same time, is considered to improve the triacetin production. The study was divided into 3 parts. In the first part, effect of key design and operating parameters on the performance of triacetin production was studied. The simulation results showed that when glycerol and acetic acid are fed into the reactive distillation at temperature of 25 °C and acetic acid to glycerol ratio of six, the glycerol conversion of 99% and the triacetin purity of 99.9% can be achieved. Based on a total annual cost analysis, the optimal configuration of reactive distillation column consists of 26 reactive stages. In the second part, design of a reactive distillation based on a concept of thermally coupled distillation sequence was performed. The energy utilization of triacetin production obtained from this arrangement was analyzed and compared to a conventional configuration without thermal coupling. The results showed the energy savings of around 48.6%. In the final part of the study, effect of feeding a crude glycerol at different ratios of methanol and glycerol on triacetin production was investigated. The results indicated that an increase of methanol in the crude glycerol derived from biodiesel production decreases the purity of triacetin obtained. In addition, the mole fraction of water at the distillate stream is decreased. However, the conversion of glycerol and the yield of triacetin obtained with crude glycerol are slightly lower than those with pure glycerol.

Department : ... Chemical Engineering ... Student's Signature

Field of Study : ... Chemical Engineering ... Advisor's Signature

Academic Year : ... 2011

ACKNOWLEDGEMENTS

The author wishes to express her sincere gratitude and appreciation to her advisor, Assistant Professor Amornchai Arpornwichanop for his valuable suggestion and useful discussion throughout this research. The author would also be grateful to Associate Professor Muenduen Phisalaphongas the chairman and Assistant Professor Soorathep Kheawhom and Dr. Woranee Paengjuntuek as the members of thesis committee.

Financial support from the 90th Anniversary of Chulalongkorn University Fund (Ratchadaphiseksomphot Endowment Fund) and the Computational Process Engineering Research Group, Special Task Force for Activating Research (STAR), Chulalongkorn University Centenary Academic Development Project is gratefully acknowledged.

The author thanks all the members in the Control and Systems Laboratory and classmates for their assistance and support.

Finally, the author would like to thank her family for inspiration, encouragement and support during the course of the study.

CONTENTS

	PAGE
ABSTRACT (THAI)	iv
ABSTRACT (ENGLISH)	v
ACKNOWLEDGEMENTS	vi
CONTENTS	vii
LIST OF TABLES	xi
LIST OF FIGURES	xii
NOMENCLATURES	xvii
 CHAPTER	
I INTRODUCTION	1
1.1 Introduction.....	2
1.2 Objectives	2
1.3 Working scopes.....	3
1.4 Expected benefits	3
1.5 Methodology of research	3
II LITERATURE REVIEWS	5
2.1 Waste glycerol from biodiesel production.....	5
2.1.1 Crude glycerol composition.....	5
2.1.2 Use of crude glycerol for various applications	6
2.2 Production of triacetin.....	8
2.3 Application of reactive distillation.....	10
2.4 Heat integrated - thermally coupled distillation systems	12

CHAPTER	PAGE
III THEORY	15
3.1 Biodiesel industry	15
3.2 Glycerol.....	16
3.2.1 Properties and manufacture of glycerol.....	16
3.2.2 Derivatives of glycerol	17
3.2.3 Industrial application	19
3.3 Triacetin (glyceryl triacetate).....	20
3.3.1 Properties and manufacture of triacetin.....	20
3.3.2 Kinetics model.....	22
3.3.3 Industrial application	23
3.4 Reactive distillation.....	24
3.4.1 Reactive distillation configurations	24
3.4.2 Advantages and disadvantages of reactive distillation	26
3.5 Heat integration of distillation columns	27
3.5.1 Distillation sequences	28
3.5.2 Heat integrated – thermally coupled distillation sequences	29
3.6 Aspen plus.....	31
3.6.1 Benefits of aspen plus.....	32
IV REACTIVE DISTILLATION FOR TRIACETIN PRODUCTION	33
4.1 Simulation of reactive distillation for triacetin production.....	33
4.1.1 Standard condition.....	34
4.1.2 Effect of reactive Stages	36
4.1.3 Effect molar ratio of acetic acid and glycerol.....	37
4.1.4 Effect of reflux ratio	39
4.1.5 Effect of feed stage location	41
4.1.6 Effect of feed temperature	42
4.1.7 Effect of distillate rate	44
4.2 Economic evaluation of reactive distillation for triacetin production.....	47
4.2.1 Assumptions and specifications.....	47

CHAPTER	PAGE
4.2.2 Determination of an optimum reactive distillation system for the triacetin	48
V ENERGY INTEGRATED REACTIVE DISTILLATION COLUMNS.....	51
5.1 Process of reactive distillation with conventional distillation column (indirect sequence)	52
5.2 Improving energy consumption in triacetin production with reactive indirect thermally coupled sequence	58
VI REACTIVE DISTILLATION FOR TRIACETIN PRODUCTION FROM CRUDE GLYCEROL	68
6.1 Configuration 1: Direct feed of crude glycerol to a reactive distillation for triacetin production.....	68
6.2 Configuration 2: Pretreatment of crude glycerol and triacetin production	73
6.3 Configuration 3: Using Crude glycerol for methyl acetate and triacetin production	78
VII CONCLUSIONS AND RECOMMENDATIONS.....	82
7.1 Conclusions.....	82
7.1.1 Simulation of reactive distillation for triacetin production Improving energy consumption in the triacetin production with reactive indirect thermally coupled sequence	82
7.1.2 Energy integrated reactive distillation columns	83
7.1.3 Reactive distillation for triacetin production from crude glycerol.....	83
7.2 Recommendations	84
REFERENCES.....	85
APPENDICES	91
APPENDIX A: MODIFIED KINETIC PARAMETERS OF METHYL ACETATE ESTERIFICATION	92

CHAPTER	PAGE
APPENDIX B: SIZING OF EQUIPMENT AND CALCULATION OF COST	94
VITA	98

LIST OF TABLES

TABLE	PAGE
3.1 Physical properties of glycerol	18
3.2 Physical properties of triacetin	22
3.3 Values of kinetic constants for esterification of triacetin production	23
4.1 Sizing and economic of single reactive distillation column for triacetin production (1 bar)	50
5.1 Feed conditions and specification of reactive distillation column and conventional distillation column	53
5.2 Total energy consumption in reactive distillation columns with conventional distillation sequences	57
5.3 Feed conditions and specification of reactive distillation column with the thermally coupled (side stripper)	59
5.4 Total energy consumption in reactive distillation columns with conventional distillation sequences	66
6.1 Feed conditions and specification in reactive distillation column for feed a mixture of glycerol and methanol	70
6.2 Feed conditions and specification in distillation column for removal methanol and the reactive distillation for triacetin production. ...	73
6.3 Feed conditions and specification in the reactive distillation column for methyl acetate production and the reactive distillation for triacetin production	79
A-1 Kinetic rate constants based on activity at various temperatures	93
B-1 Sizing of equipment	94
B-2 Notation and parameter values for sizing of equipment and cost calculation	95

LIST OF FIGURES

FIGURE	PAGE
3.1 Overall mechanism of transesterification.....	15
3.2 General reactions for the preparation of glycerol esters.....	20
3.3 Reactions for the preparation of triacetin	22
3.4 Reactive distillation column.....	25
3.5 Conventional distillation sequences for separation of ternary mixtures.....	29
3.6 TCDS for the separation of ternary mixtures	31
4.1 Single reactive distillation system for triacetin production.....	34
4.2 Temperature profile at the standard condition	35
4.3 Composition profile at standard condition	35
4.4 Effect of reaction stage on conversion when molar ratio of 5:1, reflux ratio of 1.5, distillate rate of 25 kmol/h in the reactive distillation.....	36
4.5 Effect of reaction stage on yield when molar ratio of 5:1, reflux ratio of 1.5, distillate rate of 25 kmol/h in the reactive distillation	37
4.6 Effect of molar ratio of acetic acid and glycerol on the conversion of glycerol in the reactive distillation.....	38
4.7 Effect of molar ratio of acetic acid and glycerol on the yield of triacetin in the reactive distillation.....	38
4.8 Effect of reflux ratio on conversion of glycerol when molar ratio of 5:1, distillate rate of 25 kmol/h in the reactive distillation	39
4.9 Effect of reflux ratio on yield of triacetin when molar ratio of 5:1, distillate rate of 25 kmol/h in the reactive distillation.....	40

FIGURES	PAGE
4.10 Effect of reflux ratio on condenser duty when molar ratio of 5:1, distillate rate of 25 kmol/h in the reactive distillation.....	40
4.11 Effect of feed stage of acetic acid on conversion when molar ratio of 5:1, reflux ratio of 1.5, distillate rate of 25 kmol/h in the reactive distillation	41
4.12 Effect of feed stage of acetic acid on yield when molar ratio of 5:1, reflux ratio of 1.5, distillate rate of 25 kmol/h in the reactive distillation.....	42
4.13 Effect of feed temperature of glycerol and acetic acid on the conversion in the reactive distillation.....	43
4.14 Effect of feed temperature of glycerol and acetic acid on the yield in the reactive distillation	43
4.15 Distillate flow rate analysis to determine the bottoms product purities	44
4.16 Effect of distillate rate on the conversion of glycerol in the reactive distillation	45
4.17 Effect of distillate rate on the yield of triacetin in the reactive distillation.....	45
4.18 Temperature profile in liquid phase along the reactive distillation column (feed temperature of 25 °C, molar ratio of 6:1, reflux ratio of 2 distillate rate 30 kmol/h, stages = 17 stage and feed location of glycerol and acetic at stage 3 and 2, respectively).....	46
4.19 Composition profile in liquid phase along the reactive distillation column (feed temperature of 25 °C, molar ratio of 6:1, reflux ratio of 2 distillate rate 30 kmol/h, stages = 17 stage and feed location of glycerol and acetic at stage 3 and 2, respectively)	47
4.20 Effect the number of reactive stage on total annual cost at different pressures	49
5.1 The indirect reactive distillation column with conventional distillation	52

FIGURES	PAGE
5.2 Temperature profile in the design of the reactive distillation column and conventional distillation column	53
5.3 Composition profiles of the first column in the reactive distillation column	54
5.4 Composition profiles of the second column in the distillation column.....	55
5.5 The effect of feed stage location in the distillate stream to the second column on molar fraction of acetic acid and water	55
5.6 The effect of bottom flow rate in the second column on molar fraction of acetic acid and water.	56
5.7 The effect of reflux ratio in the second column on the molar fraction of acetic acid and water	56
5.8 The reactive distillation column with the thermally coupled column configurations (side stripper).....	59
5.9 Temperature profile in the design of the reactive distillation column with the thermally coupled (side stripper).....	60
5.10 Composition profiles of the first column in the reactive distillation column	61
5.11 Composition profiles of the second column in the conventional distillation column	61
5.12 The effect of product stage location in the liquid side stream of the second column on molar fraction of acetic acid, water and triacetin.	62
5.13 The effect of feed stage location of vapor stream to the second column on molar fraction of acetic acid, water and triacetin	63
5.14 The effect of mole flow of side stream in the second column on the molar fraction of acetic acid, water and triacetin	64
5.15 The effect of changing mole ratio of acetic acid and glycerol on the molar fraction of acetic acid, water and triacetin	64
5.16 The effect of reflux ratio in the second column on the molar fraction of water, acetic acid and triacetin.....	65

FIGURES	PAGE
6.1 The reactive distillation column by feed a mixture of glycerol and methanol	69
6.2 Conversion of glycerol and yield of triacetin at different ratios of glycerol per methanol.....	70
6.3 Molar fraction of main component in the reactive distillation column when increasing the percentage of methanol in glycerol	71
6.4 Molar flow of main component in the reactive distillation column when increasing the percentage of methanol in glycerol	72
6.5 Energy consumption in the reactive distillation columns when increasing the percentage of methanol in glycerol.....	72
6.6 The distillation column for removal methanol and the reactive distillation for triacetin production.....	73
6.7 Conversion of glycerol and yield of triacetin at different ratios of glycerol per methanol in the case of removal of methanol at the first of distillation column	74
6.8 Molar fraction of main component when increasing the percentage of methanol in glycerol in the case of removal of methanol at the first of distillation column	75
6.9 Molar flow of main component when increasing the percentage of methanol in glycerol in the case of removal of methanol at the first of distillation column	75
6.10 Energy consumption in the distillation columns in the case of removal of methanol at the first of distillation column.....	76
6.11 Energy consumption in the reactive distillation columns in the case of removal of methanol at the first of distillation column.....	77
6.12 The reactive distillation column for methyl acetate production followsby the reactive distillation column for triacetin production	78
6.13 Conversion of glycerol and yield of triacetin at different ratios of glycerol per methanol in the case of occurred methyl acetate	80

FIGURES	PAGE
6.14 Molar fraction of main component when increasing the percentage of methanol in glycerol in the case of occurred methyl acetate.	80
6.15 Molar flow of main component when increasing the percentage of methanol in glycerol in the case of occurred methyl acetate	81
A-1 Arrhenius plot rate constant for finding the activation energy and the preexponential factor	93

NOMENCLATURES

A	pre exponential factor	(L/mol/s)
CSTR	continuous stirred tank reactor	(-)
RD	reactive distillation	(-)
Ea	activated energy	(cal/mol)
k_f	kinetic constant of forward reaction of esterification	(h ⁻¹)
k_e	equilibrium constant	(-)
k_r	kinetic constant of reverse reaction of esterification	(h ⁻¹)
N_f	feed location stage	(-)
R	gas constant 8.314	(J/mol/K)
TAC	total annual cost	(\$/year)
GLY	glycerol	(-)
H ₂ O	water	(-)
HAC	acetic acid	(-)
k_i	kinetic constant	(L/mol/s)
r_i	reaction rate	(mol/s)
B	bottoms flow rate	(kmol/h)
D	distillate flow rate	(kmol/h)
T	temperature	(K)
N_{rxn}	number of reactive trays	(-)
TCDS	thermal coupling distillation sequences	(-)

CHAPTER I

INTRODUCTION

1.1 Introduction

Biodiesel is an important alternative energy source that can be derived from vegetable oils or animal fats. It is biodegradable, non-toxic and environmentally friendly. In a conventional process of biodiesel production, glycerol is generated as a by-product (approximately 10 wt.% of vegetable oil) (Dasari et al., 2005). As the demand and production of biodiesel increase, a large amount of glycerol will be obtained. In general, crude glycerol derived from biodiesel production always contains impurities, e.g., methanol and soap (Thompson and He, 2006) and its composition depends on the biodiesel feedstock, the catalyst used, and the degree of post-reaction cleanup such as acidulation and demethylization (Bohon et al., 2010). This makes crude glycerol from biodiesel production process be low price. To increase the competitive potential of biodiesel, a number of researches have been being explored to find useful applications for glycerol as this could reduce biodiesel production cost.

Glycerol is considered a valuable chemical that is widely used in cosmetic, food, pharmaceutical and personal care industries. It can be used as a raw material for conversion into valued-added products using thermo-chemical methods (e.g., propylene glycol, acetol or triacetin) and biological methods (e.g., 1,3-propanediol, lipid and pigment) (Selembo et al., 2009). In addition, crude glycerol is employed as fuel for producing hydrogen gas through photo fermentation (Ito et al., 2005). Further, the production of glycerol derivatives might be of potential interest to increase the value of glycerol.

Glycerol triacetate, which is also called “triacetin”, is one of the main chemical products derived from glycerol. Not only is triacetin derived from natural

sources such as cod-liver oil, butter and other fats but also from esterification of glycerol with acetic acid. Nowadays, this chemical is used as a plasticizer in various applications, a solvent in cosmetic formulations (Wolfson et al., 2009) and also as biodiesel additive (Casas et al., 2010). Hence, the production of triacetin might be of potential interest to increase value of glycerol. Most previous studies have concentrated on the use of a conventional reactor and the synthesis of catalyst for the production of triacetin. As the esterification reaction is equilibrium limited, the application of a reactive distillation where reaction and separation occur at the same time, is an attractive alternative to overcome the thermodynamic equilibrium limitation, thus improving the triacetin production process. Further, the use of reactive distillation reduces operating cost and capital investment. However, there are few studies concerning the design of the reactive distillation for triacetin production.

The purpose of the present work is to study the esterification process of glycerol and acetic acid for the production of triacetin (triacetate ester of glycerol) by using a reactive distillation. Simulation studies of reactive distillation are performed using Aspen Plus to investigate effects of basis design and operating parameters such as reactive stages, molar ratio of acetic acid and glycerol, reflux ratio, feed stage location of glycerol and acetic acid, feed temperature and distillate rate. This leads to an optimal design of the reactive distillation for triacetin production. Further, to improve the energy efficient of reactive distillation, a heat integration of reactive distillation is also considered.

1.2 Objectives

The aim of this study is to design a reactive distillation for triacetin production from esterification of glycerol and acetic acid

1.3 Scopes of work

1.3.1 To study the synthesis of triacetin from esterification of glycerol and acetic acid in a reactive distillation. The kinetic rate of such a reaction proposed by Jordi Bonet et al. (2009) is used and simulations are performed by using Aspen plus.

1.3.2 To investigate the effect of various operating conditions such as feed locations of glycerol and acetic acid, distillation rate, reflux ratio, feed temperature and reboiler duty, on reactive distillation performance.

1.3.3 To determine an optimal design of the reactive distillation for triacetin production base on a total annual cost analysis.

1.3.4 To study the effect of using pure glycerol and crude glycerol containing methanol on the performance of reactive distillation for triacetin production.

1.3.5 To investigate a feasibility of heat integration in the reactive distillation for the production of triacetin.

1.4 Expected benefit

1.4.1 Glycerol, a by-product of biodiesel production, can be used for the production of triacetin, which is a high-value substance in various industries. This would reduce biodiesel production cost and promote competitive potential of biodiesel.

1.4.2 A suitable operating conditions and configuration of a reactive distillation for triacetin production can be determined.

1.4.3 Design of a reactive distillation based on a heat integration concept results in an improvement in the energy efficiency of the reactive distillation.

1.5 Methodology of research

1.5.1 Review the literature on related topics including biodiesel fuel, glycerol, triacetin production and reaction kinetics, reactive distillation and its applications.

1.5.2 Simulate a reactive distillation by using Aspen Plus to investigate the esterification process of glycerol and acetic acid for the production of triacetin. To study the effect of various operating conditions such as feed stage position of glycerol and acetic acid, distillation rate, reflux ratio, feed temperature and reboiler duty, on the reactive distillation performance.

1.5.3 Investigate the effect of using pure glycerol and crude glycerol containing methanol on the performance of reactive distillation for triacetin production.

1.5.4 Design a reactive distillation with heat integration for triacetin production.

1.5.5 Analyze and conclude the simulation results.

1.5.6 Write up the thesis and prepare a manuscript for publication.

CHAPTER II

LITERATURE REVIEWS

2.1 Waste glycerol from biodiesel production

Glycerol has been a well known chemical. It is increasing unavoidable formation as a by-product of biodiesel production. Thus, there is an important need to develop process for converting the expected enormous quantities of waste glycerol to a useful product. In addition, glycerol can be a platform chemical that use as an important biorefinery feedstock and conversion of glycerol to other commodity chemicals is desirable.

2.1.1 Crude glycerol composition

Crude glycerol derived from biodiesel production process is not pure because other contaminants present in the crude glycerol so the price of crude glycerol is cheap. Contaminants are found in the crude glycerol contains mostly methanol and soap also contains a variety of elements such as calcium, magnesium, phosphorous and sulfur (Thompson and He, 2006). The composition of the glycerol by-product that can change depending on the raw material for biodiesel production (e.g., vegetable oils or animal fats), the catalyst used, and the level of post-reaction cleanup such as acidulation and demethylization (Bohon et al., 2010). Many research studied the features of crude glycerol from biodiesel production. For example, Thompson and He (2006) have characterized the glycerol produced from various biodiesel feedstocks such as mustard, rapeseed, canola, crambe, soybean, and waste cooking oils. They studied characterized the crude glycerol for its physical, chemical, and nutritional properties. They found that the crude glycerol from any feedstock is generally between 60 and 70 % (wt) glycerol. Mustard seed feedstock generated a lower level

62% of glycerol, while soy oil feedstock had 67.8% of glycerol and waste vegetable had the highest level 76.6% of glycerol. Thompson and He (2006) reported that the elements present in the glycerol of different feedstock sources namely canola, rapeseed and soybean were similar. Calcium was in the range of 3-15 ppm, magnesium was 1-2 ppm, phosphorous was 8-13 ppm, and sulfur was 22-26 ppm. However, when crambe (oilseed plant) was used as feedstock, crude glycerol included the same elements, but largely different concentrations.

Schroder and Sudekum (1999) also reported the elemental composition of crude glycerol from rapeseed oil raw material. Phosphorous was found to be between 1.05 % and 2.36 % (w/w) of the crude glycerol. Potassium was between 2.20 % and 2.33%, while sodium was between 0.09% and 0.11%. Cadmium, mercury, and arsenic were all lower than the limit are detected.

2.1.2 Use of crude glycerol for various applications.

Because the amount of glycerol derived from biodiesel production process has increased continuously. In addition, purification is relatively expensive, which makes the process of crude glycerol from biodiesel are greater purity such as filtration, chemical additions and fractional vacuum distillation for use in the food, pharmaceutical, or cosmetics industries. Further purification steps such as bleaching, deodorization and ion exchange are required to remove trace impurities. Purification crude glycerol is costly and often out of the range of economical feasibility for small and medium sized plants. Therefore it is necessary for the use of crude glycerol various methods for disposal and utilization of this crude glycerol including combustion, anaerobic digestion, composting, animal-feeding, thermo-chemical conversions and biological conversion to increase the value of products.

Some simple methods for the usage of glycerol have been proposed. For example, Athalye et al. (2009) studied the potential of using crude glycerol for producing eicosapentaenoic acid (EPA, 20:5 n-3) by the fungus *Pythium irregular* which is producing value-added products through microbial fermentation. The result showed that the main impurities in the crude glycerol are soap and methanol, were inhibitory the growth of fungi.

Lammers et al. (2008) investigated the apparent digestible and metabolizable energy values of crude glycerin for growing pigs. Kerr et al. (2009) also studied the energy value of crude glycerol from various biodiesel production enable was determined in nursery pigs to predict apparent digestible and metabolizable energy based on the composition of crude glycerin. Lopez et al. (2009) studied the anaerobic digestion of glycerol derived from biodiesel manufacturing. They were studied in batch laboratory-scale reactors at mesospheric temperature using granular and non-granular sludge. The anaerobic revalorization of glycerol using granular sludge achieved a biodegradability of around 100%. The results indicated that the anaerobic digestion could be a good option for revalorizing this available, impure and low priced by-product derived from the surplus of biodiesel companies.

Crude glycerol can be used as a raw material for conversion into valued-added products such as propylene glycol and acetol by means of thermo chemical methods or 1,3-propanediol, lipid and pigment by way biological.

In addition, crude glycerol was also used as feedstock for producing hydrogen gas through photo fermentation. For instance, Selembo et al. (2009) studied converting of glycerol into high value products, such as hydrogen gas and 1,3-propanediol (PD), was investigated by anaerobic fermentation with a mixed cultures that has been heat-treated. The results demonstrate that production of biodiesel can be combined with the production of hydrogen and 1,3-propanediol for the best use of resources and reduce waste.

Ito et al. (2005) studied the production of hydrogen and ethanol from glycerol containing wastes released after a manufacturing process for biodiesel. They studied the use of microorganisms is *Enterobacter aerogenes* HU-101.

Sabourin-Provost et al. (2009) studied the photosynthetic bacterium *Rhodospseudomonas palustris* is ability of the photofermentative conversion of glycerol, both pure and a crude glycerol fraction, hydrogen fuel in the future. In their study, yields obtained with the crude glycerol were nearly or only slightly lower than those seen with the pure substances.

Posada et al. (2010) also studied the production of ethanol from crude and pure glycerol are designed and assessment of the economy. These processes consider the glycerol fermentation to ethanol is used with *Escherichia coli*. The results showed

that the cost of production of ethanol fuel from raw glycerol will be lower than the commercial price of fuel ethanol.

2.2 Production of triacetin

Glycerol triacetate (which is also called “triacetin”) is produced by the reaction of acetic acid with glycerol and used as a plasticizer in various applications, solvent in cosmetic formulations and also as food and biodiesel additive. Furthermore, the production of triacetin might be of potential interest to increase value of glycerol. Therefore, it is important to study production of triacetin. In general, the study of triacetin is study about the catalyst used in the production process triacetin. For the homogeneous catalytic process there are several problems such as corrosion by the acid catalysts and the requirement of an extra process to remove the acid catalyst after the reaction process. Recently, much attention has been studied the heterogeneous solid catalyst, to overcome the problems of using the homogeneous catalyst. Many studied using heterogeneous solid catalyst for the production of acetic acid esters such as methyl acetate, ethyl acetate, iso-amyl acetate, phenyl acetate, and glycerol triacetate. For example, Goncalves et al. (2008) studied the acetylation of glycerol with acetic acid catalyzed by different solid acids. Reactions were performed in batch mode under reflux. Kinetics of the conversion of glycerol and a selection of products, especially mono, di and triacetyl esters has been considered within 30 min of reaction time for the main product. The results showed that the Amberlyst-15 acid resin offered the best performance, with the highest conversion and selectivity to di and triacetylated products. Zeolites HZSM-5 and HUSY presented the worst performance, maybe caused diffusion and acid site deactivation problems.

Balaraju et al. (2009) studied acetylation of glycerol to yield mono, di and triacetin was carried over niobic acid supported tungstophosphoric acid (TPA) catalysts. The results suggest that the conversion of glycerol and selectivities depend on the acidity of the catalysts, which is related to the content of TPA on niobic acid. The change in conversion and selectivities during the acetylation also is recognized to the reaction time, the concentration of catalyst and glycerol to acetic acid molar ratio.

Reddy et al. (2010) investigated acetylation of glycerol with acetic acid over ZrO_2 , TiO_2-ZrO_2 , WO_x/TiO_2-ZrO_2 and MoO_3/TiO_2-ZrO_2 solid acid catalysts to synthesize monoacetin, diacetin and triacetin. The effect of various parameters such as reaction temperature, molar ratio of acetic acid to glycerol, catalyst wt.% and time-on stream were studied to optimize the reaction conditions. In their experiment, the MoO_3/TiO_2-ZrO_2 combination exhibited highest conversion (~100%) with a selection of the best product.

Furthermore, there is also studied of the triacetin as utilized for solvent or additive such as Wolfson et al. (2009) studied triacetin used as a green solvent and as the acyl donor in the transesterification of isoamyl alcohol to produce isoamyl acetate using free and immobilized *Candida antarctica* lipase B. The result showed that the use of triacetin as the solvent also enabled the separation of the product by simple extraction with petroleum ether and recycling the catalyst.

Casas et al. (2010) investigated the impact of triacetin on the quality of biodiesel. They were testing the effectiveness of the quality of biodiesel standards when triacetin is present at different concentrations in the biodiesel. In their experiment, the measure properties for mixtures of triacetin and biodiesel composed of various amounts of triacetin of up to 20 wt % and different biodiesels. The results indicated that the content of triacetin does not have to be limited according to the ASTM D6751 guidelines.

The synthesis of triacetin from glycerol and acetic acid using reactive chromatography on acidic polymeric resins was investigated by Gelosa et al. (2003). They studied the characterization of the adsorption equilibrium of the involved multicomponent mixtures and then to the studied of the kinetics of the associated with the reactions using a batch reactor. In addition, the separation-reaction process is investigated using a fixed-bed chromatographic column. The results shown that, the chromatographic reactor can produce high purity triacetin with high conversions. In their research, found that the presence of water in the resin at the end of the regeneration step has become extremely dangerous effect on the final triacetin purity.

Bonet et al., (2009) investigated the possibility of the change in an efficient integrated continuous process which is suitable for processing high quantities of

glycerol. In their experiment, a kinetic model was determined for the production of triacetin from glycerol and acetic acid in the absence of catalyst.

2.3 Application of reactive distillation

Reactive distillation is an excellent example of process intensification. It can provide an economically and environmentally attractive alternative to conventional multiunit flowsheets in some systems. There are various reactions that satisfy this criterion, but this technology is applied only for etherification, esterification, and alkylation (synthesis of ethylbenzene or cumene) on an industrial scale (Tuchlenski et al., 2001). There are many research reported for steady-state and dynamic simulations of reactive distillation. For example, Chien et al., (2004) studied design and control of a realistic coupled reactor/column process to produce ethyl acetate. The optimum process design is the one that minimize the Total Annual Cost (TAC) of process. In their studied, the process included a continuous-stirred tank reactor (CSTR) coupled with a rectifier, a decanter, another stripper, and a recycle stream.

Design and control of butyl acrylate reactive distillation column system was presented by Zeng et al. (2006). They proposed simple design of the overall system with only one reactive distillation column and an overhead decanter. The optimal design flowsheet is determined by minimizing TAC. Furthermore, studied output multiplicity of this system is responsible for the reboiler duty or feed ratio as a parameter. The result found that butyl acrylate has high purity at 99.83 mol% can be obtained from the bottom of the reactive distillation column.

Furthermore, the other research about reactive distillation i.e. *n*-hexyl acetate (Schmitt et al., 2003), methyl acetate (Huss et al., 2003), ethyl and isopropyl acetates (Lai et al., 2006).

To improve the energy efficiency of separation processes, several heat integrated techniques have been proposed i.e. Wang et al., (2008) investigated the design and control strategies of a reactive distillation process with partially thermal coupling for the production of methanol and *n*-butyl acetate by transesterification reaction of methyl acetate and *n*-butanol. In their research, partially thermal coupling can be used to eliminate the condenser of the second column. The result showed that,

not only energy reduction but also better operability and controllability can be obtained for the thermally coupled reactive distillation process.

Mascia et al., (2006) presented the synthesis of partially thermally coupled and heat-integrated distillation systems applied to the light ends separation section of a crude distillation plant. The result showed that, a thermally coupled configuration showed the best performances for the considered separation.

Design of reactive distillation with thermal coupling for the synthesis of biodiesel using genetic algorithms was studied by Miranda-Galindo et al., (2009). The esterification of lauric acid and methanol is explored using a thermally coupled distillation sequence with a side rectifier and the Petlyuk distillation column. In their studied, the design tools using multi objective genetic algorithm with restrictions.

They found that the thermally coupled distillation sequence involving a side rectifier can produce biodiesel with a high purity (around 0.999) and also pure water, and the excess of methanol is recovered in a side rectifier. The results indicated that the energy consumption of the complex distillation sequence with a side rectifier can be reduced significantly by varying operational conditions.

Design of a reactive distillation column for direct preparation of dichloropropanol from glycerol was presented by Luo et al. (2009). In their experiment, a pilot plant scale column designed by using a simple equilibrium mathematical model of reactive distillation. Furthermore, the whole preparation process of dichloropropanol from glycerol used the optimum reactive distillation column as the central unit is simulated by using an advanced software tool, namely ASPEN PLUS. The result both by simulation and pilot plant scale showed that, it is feasible to produce dichloropropanol via a new process using a reactive distillation column as the central unit.

Bonet et al., (2009) simulate the feasibility of triacetin synthesis by reactive distillation using Aspen Plus. The results showed that a high purity of triacetin is obtained in the reactive distillation column bottom due to the continuous removal of water generated by the reaction which is collected finally in the distillate.

2.4 Heat integrated - thermally coupled distillation systems

Due to the fact that distillation is a highly energy intensive process, energy consumption is important in the design and operation in this unit. Most of the application of previous research in sidestream has considered a system containing three components with the reduction order of volatilities. Then, sidestream of the column is often used in case of very small amounts of either the lightest component or the heaviest components see also Glinos and Malone (1985) and Luyben et al., (1999). To improve the purity of the sidestream of the three ways design were introduced namely sidestream with small stripper (SS), small rectifier (SR) and prefractionator (PF) respectively. In the SS, liquid sidestream is fed at the top of stripping column. This stripping column has a small reboiler to strip out the lightest component. While, in the SR the vapour sidestream is fed in the base of rectifying column to remove some of the heaviest component in the vapour stream. The last one, prefractionator column, consists of prefractionator to perform a rough separation and followed by the final separation into three products stream in a two-feed sidestream column. (Suhendra, 2006)

Other interesting configurations for energy conservation purposes are namely Petlyuk column or divided wall column and heat integrated distillation column. The implementation of a vapor-liquid interconnection between two columns, a condenser or a reboiler of the columns is eliminated, and the search for the appropriate operating conditions is implemented, such an interconnection can provide energy savings (Hernandez and Jimenez, 1999). TCDS for ternary mixtures have particularly been analyzed with special interest. Two of the schemes that have received special attention are systems with the side of columns (Finn,1993; Hernandez and Jimenez, 1999): the thermally coupled system with a side rectifier, TCDS-SR, and the coupled system with a side stripper, TCDS-SS.

For example, Kim (2002) designed procedure for fully thermally coupled distillation columns (FTCDC). He applied to the example system of butanol isomers in order to show the design performance. The procedure providing structural information of the column, and therefore iterative computation encountered in the design using conventional procedure and commercial packages can be eliminated. He

investigated by using the outcome of the structural design, other topics, such as thermodynamic efficiency, dividing wall column structure and the arrangement of interlinking streams. From the result of the design for the example system and the comparison of calculated liquid composition with a commercial design tool, it is proved that the proposed procedure is useful.

Thermally coupled distillation systems (TCDS) have been proposed by Ramirez and Jimenez (2004) to perform distillation separation tasks with the incentive of achieving lower energy consumption levels with respect to conventional distillation. It has been shown that the new systems can operate the separations tasks with energy efficiency similar to or better than that of thermally coupled systems. The simple structure of the new systems was conceived as an option to the integrated schemes.

Barroso-Munoz et al., (2007) presented a study of the production of ethyl acetate from ethanol and acetic acid through three reactive thermally coupled systems: a thermally coupled distillation sequence with a side stripper, a thermally coupled distillation sequence with a side rectifier and a Petlyuk-type column. The results showed that thermally coupled distillation systems present important advantages over the conventional process used to produce ethyl acetate. Especially in the Petlyuk column turned out to be the most convenient because of demand the lower energy to achieve a production of ethyl acetate similar to those obtained in the thermally coupled distillation sequences with side columns.

Malinen and Tanskanen (2007) studied the thermally coupled side-rectifier and side-stripper configurations to separate the component of sets with a curved distillation boundary. They recommend steps that can be used to determine the total minimum energy consumption for the separation complex structures. The results found that thermally coupled side-column configurations enable distillation boundary crossing with high product flow purities. According to the simulation results, thermally coupled side column configurations enable a distillation boundary crossing in a way more flexible than traditional direct and indirect column sequences. This conclusion is based on the observation that in the situations where the distillation curve boundary is present, while the thermally coupled side-column configurations

enable surprisingly higher purities of product to be successful, that is the feasible product composition area is wider than with conventional columns.

Lee et al., (2008) modified fully thermally coupled distillation column for operability development is utilized in a gas concentration process for the saving of energy consumption. It can be seen that the designs of thermally coupled have important savings in energy and capital costs when compared with conventional column designs.

Furthermore, has been studied reactive distillation with thermal coupling such as Miranda-Galindo et al., (2011) have studied the design of reactive distillation with thermal coupling using a case study of the production of fatty esters. The esterification of methanol and lauric acid by using sulfuric acid, as catalyst in direct and indirect reactive sequences, both conventional and thermally coupled. The results show that obtaining the ester with a purity of 99.9% is feasible in conventional and thermally coupled distillation sequences. The results showed that the energy consumption of the complex distillation sequence can be reduced significantly at different operating conditions. However, lower energy consumptions, and lower CO₂ emissions, has been observed in the thermally coupled sequences.

The researcher expected that the Petlyuk sequence could be a better option, in terms of energy requirements, for reactions where the major product is always more rich than the unreacted component and byproducts.

CHAPTER III

THEORY

3.1 Biodiesel industry

The increase in fuel use and other beneficial policies have also given rise to an imposing increase in biodiesel production companies. Biodiesel was essentially the most beneficial pieces of alternative fuel. It is also biodegradable and nontoxic significantly less emissions than petroleum-based diesel fuel.

Biodiesel can be produced from several of feedstocks. These materials include the most commonly used vegetable oils such as rapeseed, soybean, peanut, palm, sunflower, jatropha and the production of animal fats such as tallow as well as waste cooking oils. Several techniques for the production of biodiesel from vegetable oils and animal fats can be converted into biodiesel for example transesterification, enzyme lipase, pyrolysis, super critical fluid extraction. The transesterification is the reaction between triglyceride and alcohol to form biodiesel and glycerol by using catalyst. The reaction is shown in the Figure 3.1

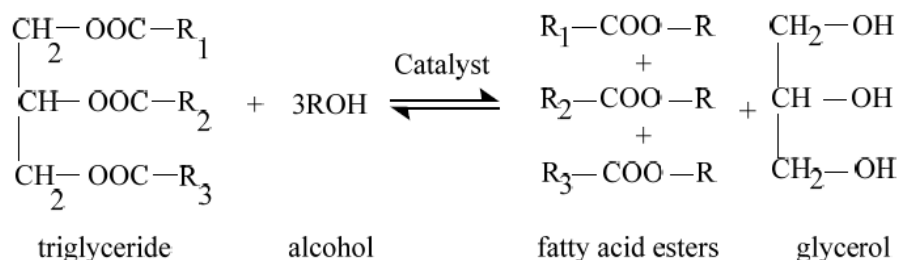

Figure 3.1 Overall mechanism of transesterification

Methanol is used as the alcohol for producing biodiesel because it is cheaper than other alcohols, so the final products are also called fatty acid methyl esters (FAME) instead of biodiesel. By-product of this production is glycerol, also known as

glycerin. Biodiesel is a liquid which varies in color between golden and dark brown depending on the raw material. It is immiscible with water, high boiling point and low vapor pressure. Biodiesel has better lubricating properties and much higher cetane rating than diesel fuels. Biodiesel in the future will very likely to see a significant as a way toward reducing dependence on foreign oil, improving the environment, creating manufacturing jobs, and being an outlet for value-added agricultural products.

3.2 Glycerol

3.2.1 Properties and manufacture of glycerol

Glycerol is an organic compound, also known as glycerin or glycerine. It is a clear, colorless, odorless, viscous liquid with a sweet taste nature. Glycerol is derived from both natural and petrochemical feedstocks. It occurs naturally in combined form as glycerides in all animal and vegetable fats and oils, and is recovered as a by-product when these oils are saponified in the process of manufacturing soap, when the oils or fats are split in the production of fatty acids, or when the oils or fats are esterified with methanol (or another alcohol) in the production of methyl (alkyl) esters. “Glycerol” applies to the pure chemicals compound, 1,2,3-propanetriol. “Glycerin” applies to the purified commercial products usually containing >95% of glycerol. Various grades of glycerin are available commercially. They change somewhat in their content of glycerol and other characteristics such as color, odor, and remain impurities. Physical properties of glycerol are listed in Table 3.1. Glycerol is completely soluble in water and alcohol, slightly soluble in diethyl ether, ethyl acetate, and dioxane, and insoluble in hydrocarbons (Physical Properties of Glycerin and Its Solutions, 1975).

Glycerol from glycerides (natural glycerol) is obtained from three sources: soap production manufacturing and production of fatty acid and fatty ester. In the manufacture of soap, fat is boiled with a caustic soda (sodium hydroxide) solution and salt. Fats react with the caustic to form soap and glycerol. In producing fatty acids, the most common process is continuous and high-pressure. The fat is split by the water

into fatty acids and glycerol. Fatty acids are withdrawn from the top of the column, and the glycerol containing the aqueous phase falls and is withdrawn from the bottom.

Separation of fatty acids is used to make soap, reduced to the matching fatty alcohol, or fatty acid is marketed. A third source of natural glycerol is the transesterification of oils or fats with an alcohol to produce fatty esters. The glycerol is separated from the usually methyl esters, by water washing. Acidification with hydrochloric acid and removal of remaining methanol produce a crude glycerol with a salt content of a few percent.

3.2.2 Derivatives of glycerol

Glycerol derivatives are obtained as mixtures containing isomers and products of different degrees of reaction. The relative amounts of the several products reflect their ease of formation. As a result of their receptivity, the synthesis of many different derivatives is possible. Glycerol can theoretically yield eleven oxidation products containing the original three-carbon chain. All of these compounds have been isolated and identified, but in some cases they are prepared by indirect methods rather than by direct oxidation of glycerol. Glycerol is easily reduced to propylene glycol (1, 2,-dihydroxypropane) with hydrogen at pressures from 10 to 100 atmospheres and temperatures above 150 °C. Many catalysts may be used, e.g., Ni, Fe, Pt, Au, Hg, copper chromite or tungstic acid. (Puis et al., 1941)

The esters of glycerol are the commonest and most diverse group of glycerol derivatives. As the natural glycerides, the fats and oils, they occur throughout the animal and vegetable kingdoms. Many glycerides are prepared commercially from glycerol and fatty acids. In addition there are also the esters of inorganic acids. Among the most widely used commercial esters are alkyd resins, ester gums, nitroglycerine and monoglycerides. Esters can be prepared by reacting glycerine with an acid, ester, acid chloride and anhydride or by indirect means. There are five general reactions for the preparation of glycerol esters:

Table 3.1 Physical properties of glycerol

Property	Value
Melting point (°C)	18.17
Boiling point (°C)	
0.53 kPa	14.9
1.33 kPa	166.1
13.33 kPa	222.4
101.3 kPa	290
Specific gravity, 25/25 °C	1.2620
Vapor pressure (Pa)	
50 °C	0.33
100 °C	526
150 °C	573
200 °C	6100
Surface tension (20 °C, mN/m)	63.4
Viscosity (20 °C, mPa.s)	1499
Heat of vaporization (J/mol)	
55 °C	88.12
95 °C	76.02
Heat of solution to infinite dilution (kJ/mol)	5.778
Heat of formation (kJ/mol)	667.8
Thermal conductivity [W/(m.K)]	0.28
Flash point °C	
Cleveland open cup	177
Pensky-Martens closed cup	199
Fire point (°C)	204

Glycerol can form mono-, di-, and triethers. They may be either ethers of glycerol with itself (polyglycerols), inner ether (glycidol), or mixed ethers of glycerol with other alcohols. Glycerol ethers are important commercially as solvents and plasticizers for cellulose derivatives and lacquers, an ingredient of alkyd resins, as chemical intermediates for making detergents and surface active agents and as perfume fixatives. Glycerol amines are formed by the replacement of one or more of the hydroxyls by amine groups. They are basic compounds, generally water soluble and hygroscopic. With fatty acids they form soaps that are soluble in organic solvents. The glycerol mono-, and diamines are readily made from the corresponding chlorohydrins or bromohydrins, while the triamine is usually prepared from non glycerol origins. The acetals of glycerol, formed by the condensation of glycerol with aldehydes and ketones are heterocyclic compounds. They are formed by the condensation of two hydroxyls of a glycerol molecule with the carbonyl of an aldehyde or a ketone.

3.2.3 Industrial application

Traditional applications of glycerol, either directly as an additive or as a raw material, range from its use as a food, tobacco and drugs additive to the synthesis of trinitroglycerine, alkyd resins and polyurethanes (Figure 3.2). Currently, the amount of glycerol that goes annually into technical applications is around 160,000 tones and is expected to grow at an annual rate of 2.8% (Bonnardeaux, 2006). Of the glycerol market, pharmaceuticals, toothpaste and cosmetics account for around 28%, tobacco 15%, foodstuffs 13% and the manufacture of urethanes 11%, the remainder being used in the manufacture of lacquers, varnishes, inks, adhesives, synthetic plastics, regenerated cellulose, explosives and other miscellaneous industrial uses. Glycerol is also increasingly used as a substitute for propylene glycol.

Glycerol is used in medical and pharmaceutical preparations, mainly as a means of improving smoothness, providing lubrication and as a humectant, that is as a hygroscopic substance which keeps the preparation moist. Glycerol helps to maintain texture and adds humectancy, controls water activity and prolongs shelf life in a host

of applications. It is also widely used as a laxative and, based on the same induced hyperosmotic effect, in cough syrups (elixirs) and expectorants.

In personal care products glycerol serves as an emollient, solvent, and lubricant in an enormous variety of products, including toothpaste, where its good solubility and taste give it the edge on sorbitol. Toothpastes are estimated to make up almost one-third of the personal care market for glycerol.

Glycerol in the market is currently undergoing radical changes, driven by very large supplies of glycerol from biodiesel production. Researchers and industry have been looking at the uses of glycerin to replace petroleum as a source of chemical raw materials. Glycerol is now becoming established as a key platform for the production of chemicals and fuels.

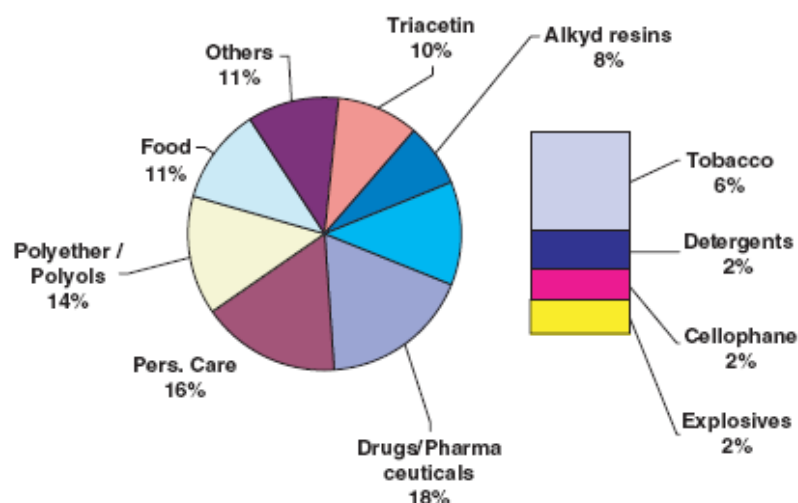

Figure 3.2 Market for glycerol (Pagliaro and Rossi, 2008)

3.3 Triacetin (glyceryl triacetate)

3.3.1 Properties and manufacture of triacetin

The acetins are the mono-, di-, and triacetates of glycerol that form when glycerol is reacted with acetic acid. Monoacetin (glycerol monoacetate [26446-35-5]) is a thick hygroscopic liquid, and is sold for use in the manufacture of explosives, in

tanning, and as a solvent for dyes. Diacetin (glycerol diacetate [25395-31-7]) is a hygroscopic liquid, and is sold in a technical grade for use as a plasticizer and softening agent and as a solvent.

Triacetin (also named Glycerin Triacetate [102-76-1]) is the tri-ester of glycerol and acetic acid. It occurs naturally in small quantities in the seed of *Euonymus europaeus* and produced from high grade glycerine on dedicated equipment, again based on renewable raw materials. Triacetin can be produced quantitatively by refluxing glycerol with acetic anhydride and a small amount of sodium acetate (or by heating with glacial acetic acid and a catalyst - though the latter is not quantitative it is more economical. The esterification of glycerol with chloracetic acid is a series of bimolecular reactions. The formation of the mono-ester is slower than that of the di-ester, and the formation of the tri-ester is more rapid than either of the preceding steps. Triacetin has a very slight odor and a bitter taste. The physical properties of triacetin are listed in Table 3.2. It's good stability and its compatibility with other chemicals, and also in particular the lack of toxicity of the high-purity product means that it can be used in a wide range of applications.

Table 3.2 Physical properties of triacetin (Eastman Chemical Company., 1999)

Property	Value
Molecular Weight (Theoretical)	218.2
Empirical Formula	C ₉ H ₁₄ O ₆
Physical Form	Liquid
Boiling Point @ 760 mm, °C (°F)	258 (496)
Freezing Point, °C	3.2 (Supercools to about -70°C)
Solubility in Water @ 20°C, g/L	61.2
Viscosity (ASTM D 445), cP (mPa·s)	
@ -17.8°C (0°F)	1,111
0°C (32°F)	107
25°C (77°F)	17.4
100°C (212°F)	1.8
Flash Point (Cleveland Open Cup), °C (°F)	153 (308)
Fire Point (Cleveland Open Cup), °C (°F)	160 (320)
Autoignition Temperature, °C (°F)	432 (810)

3.3.2 Kinetics model

The rate expressions of each reaction step are shown as follows:

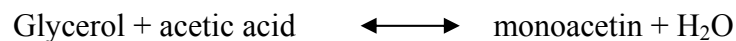

$$r_1 = k_1 C_{\text{glycerine}} C_{\text{acetic acid}} - k_{-1} C_{\text{monoacetin}} C_{\text{H}_2\text{O}} \quad (1)$$

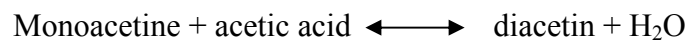

$$r_2 = k_2 C_{\text{monoacetine}} C_{\text{acetic acid}} - k_{-2} C_{\text{diacetin}} C_{\text{H}_2\text{O}} \quad (2)$$



$$r_3 = k_3 C_{\text{diacetin}} C_{\text{acetic acid}} - k_{-3} C_{\text{triacetin}} C_{\text{H}_2\text{O}} \quad (3)$$

Figure 3.3 Reactions for the preparation of triacetin

Kinetic rate constants of the reactions are necessary information for process simulation. This work focuses on the production of triacetin from esterification

reaction of glycerol and acetic acid. The kinetic parameters can be explained by the Arrhenius law.

An Arrhenius-type model is used:

$$k_i = a_i e^{-E_{ai} / RT}$$

The reaction rate is negligible at room temperature. However, at boiling point, the reaction rate is fast enough and the presence of catalyst is not required. The kinetic determinations are performed in the absence of catalyst, at 393 and 433 K, with an excess of acetic acid four times the required quantity imposed by stoichiometry. Table 3.3 shows the kinetic constants of the esterification reaction of triacetin production (Bonet et al., 2009).

Table 3.3 Values of kinetic constants for esterification of triacetin production

Reaction	A_j (L/mol.s)	E_{aj} (cal/kmol)	A_{-j} (L/mol.s)	E_{a-j} (cal/kmol)
1	5.24×10^{-4}	616.8	8.56×10^{-4}	-3864.4
2	9.69×10^{-5}	-1462.3	2.16×10^2	8701.1
3	6.26×10^{-2}	4964.1	1.86	5137.5

3.3.3 Industrial application

Most commercial triacetin is USP grade. Its primary use is as a cellulose plasticizer in the manufacture of cigarette filters; its second largest use is as a component in binders for solid rocket fuels. Smaller amounts are used as a fixative in perfumes, as a plasticizer for cellulose nitrate, in the manufacture of cosmetics, and as a carrier in fungicidal compositions. Triacetin is also used in food industry as solvents, flavorings and humectant. It is also used to fuel additive as an anti-knocking agent which can reduce engine knocking in gasoline, and to improve cold and viscosity properties of biodiesel.

3.4 Reactive distillation

Reactive distillation is a good example of process intensification. It can provide an attractive alternative to the economic and environmental consequences of conventional multiunit flowsheets in some systems. One significant advantage of reactive distillation is the feature of simultaneous production and disposal of products. For reversible chemical reactions, the removal of the product components drives the reaction toward the product side. Thus, the chemical equilibrium constraint on conversion can be overcome and high conversions can be achieved, even in cases with small chemical equilibrium constants. Of course, the relative volatilities between the reactants and the products must be such that the products can be moderately easily removed from the region in the column where the reaction is occurring and reactants are not lost from this region.

The major limitation of reactive distillation is the need for a equivalent between the temperature favorable for reaction and the temperature favorable for separation. Because both operations occur in a single vessel operating at a single pressure, the temperatures in a reactive distillation column are set by vapor–liquid equilibrium and tray compositions. If these temperatures are low and produce low specific rates of reaction for the reaction kinetics associated with very large holdups (or large amounts of catalyst) will be required. If these temperatures are high, and consistent with the chemical equilibrium constant is very small (as can happen with an exothermic reversible reactions), it may be difficult to achieve the desired conversion. High temperatures may also promote undesirable side reactions. In either the case of low- or high-temperature, reactive distillation may not be economical. As a result, the design of reactive distillation columns is much more sensitive to pressure than a conventional distillation column.

3.4.1 Reactive distillation configurations

A conventional configuration for a process involving a catalytic chemical reaction with a solid catalyst involves two steps of chemical reaction and subsequent separation. In the chemical reaction step, reactants are brought into contact with solid

catalysts at appropriate process conditions in one or more reactors. The stream leaving the reactor section then goes to one or more separation steps where unconverted reactants are separated from the products of the reaction and the inerts. The unconverted reactants, in some cases, may be recycled to the reaction section. When a substantial amount of inerts are present in the system, at least two separation units for separation of high purity product and for separation of the unconverted reactants from the inerts are required. The separation process typically chosen is distillation. An Ideal reactive distillation column is shown in Figure 3.4. The middle section of the column is the reactive distillation section. For a non-azeotropic chemical system, separation of the inerts takes place in the rectification section of the column and the purification of the product takes place in the stripping section.

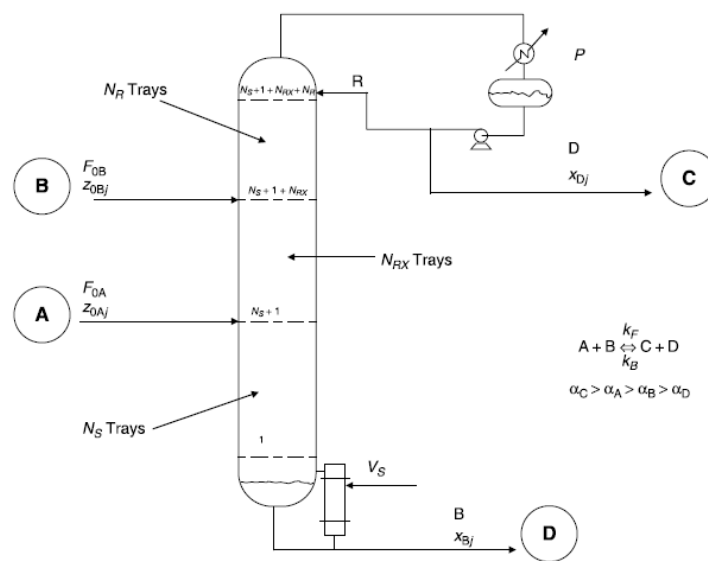

Figure 3.4 Reactive distillation column.

In the presence of a solid catalyst bed, the reactive distillation can be carried out in several different configurations. In one configuration, the solid-catalyzed chemical reaction and the multistage distillation occur simultaneously. Both reaction and distillation take place in every thin horizontal slice of the reactive distillation section of the column. In the other configuration, the reaction and distillation proceed in alternating steps. Here, the reactive distillation section of a column contains both

the catalyst contact device and the distillation device. A reaction occurs in the catalyst contact device and then the reacting phase passes to the distillation device for vapor/liquid contact and separation. These two steps occur alternately. By making the steps of infinitely small size, this configuration becomes equivalent to the first one. In both configurations, a rectification section may be located above the reactive distillation section of the column and a stripping section may be located below it, depending upon purity specifications. In some systems a combination, as shown in Figure 3.5, of the conventional process and reactive distillation may be optimal. Since part of the conversion is shifted to the reactive distillation column, the size of the fixed-bed reactor becomes smaller than in the conventional process, or the number of reactors may be decreased. The reactor effluent is the reactive distillation column feed and the remaining conversion takes place in the reactive distillation zone.

3.4.2 Advantages and disadvantages of reactive distillation

Application of RD to a catalytic chemical reaction using solid catalysts leads to a substantial cost savings compared to a conventional process. These savings result from:

1. A significant benefit of RD technology is a reduction in capital investment, because two-steps process can be performed on the same device. Such an integration leads to lower costs of pumps, piping and instrumentation.

2. If RD is applied to exothermic reaction, the reaction heat can be used for vaporization of liquid. This leads to savings of energy costs by the reduction of reboiler duties. Endothermic reactions are not suitable for the RD-technology because of vapor condensation. Although the endothermic reactions to the reboiler duty and therefore show no large energy savings, there are no limitations to the application of RD.

3. The highest temperature in the reaction zone is limited to the boiling point of a mixed reaction to the danger formation of hot spot on the catalyst can be reduced significantly. A simple and reliable temperature control can be achieved.

4. Product selectivities can be improved due to a fast removal of reactants or products from the reaction zone. By this, the probability of consecutive reactions, which may occur in the sequential operation mode, is lowered.

5. If the reaction zone in the RD column is placed above the feed position, poisoning of the catalyst can be avoided. This leads to longer lifetime of catalyst compared to the general systems.

However applying RD-technology in industrial scale, three constraints has to be fulfilled:

1. The use of RD technology is only possible, if the temperature window of the vapor-liquid equilibrium is equivalent to the reaction temperature. By changing the column operation pressure, this temperature window can be altered. However, the thermal stability of the catalyst can limit the upper operation temperature of the distillation column.

2. Because of the necessity of wet catalyst pellets the chemical reaction has to take place entirely in the liquid phase.

3. As it is very expensive to change the catalyst in a structured catalytic packing catalysts with a long lifetime are strongly required.

3.5 Heat integration of distillation columns

The principal heating and cooling duties related to the distillation column are the reboiler and condenser duties. In general, however, there will be other duties related with heating and cooling of feed and product streams. These reasonable heat duties usually will be small in comparison with the latent heat changes in reboilers and condensers. Reboiling and condensing processes, both occurring in the normally take place over a range of temperature. Considerations in practice, however, generally order that the heat is required to the reboiler at a temperature above the dew point of the vapor from the reboiler and that the heat released in the condenser must be removed at a temperature lower than the bubble point of the liquid. Thus, in the initial design at least, both reboiling and condensing can be assumed to take place at constant temperatures. (Robin Smith, 2005)

3.5.1 Distillation sequences

In the case of ternary mixtures, there are two conventional distillation sequences, which are shown in Fig. 3.5. For the separation of the three TCDS schemes commonly used (see Fig. 3.6). The energy savings predicted in the TCDS schemes are achieved due to the reduction or elimination of remixing presented in conventional distillation sequences. Remixing occurs in traditional distillation sequences and it is associated with higher energy demands; such as, for the conventional direct distillation sequence (Fig. 3.5a), the sequence represented in figure 3.5a is used when the feed has a high concentration of the lightest components or when the separation of the middle distillate and the heavy product is a little more difficult than that of the light and middle distillate. The light component can be removed as a distillate and the rest of the product being sent to a second column to be carried out the following separation. The columns are separated by a single liquid stream so that they may be operated at different pressures in order to achieve the optimum separation. For figure 3.5b this arrangement is most often used when the feed has a high concentration of the heavy product or when the separation of the light from the middle distillate is relatively more difficult. The heavy product is separated out then the distillate is fed to a second column for more separation. For the vapor from a partial condenser the pressure in the second column needs to be lower than that of the first column for natural flow of the vapor, at the compressor would be required between the columns. If a total condenser has been used then the pressures in each column can be maintained and enhanced independently.

Such a result is known as remixing and causes the needs of energy is large, because, in order to re-purify the binary mixture BC in the second column, more energy is required in the conventional distillation sequence. This remixing can be analyzed as a thermodynamic inefficiency in the use of energy. In the TCDS sequences, the stream recycling can help reduce the remixing and the energy consumption required for ternary separations, as reported in the work of Hernandez et al., (2003).

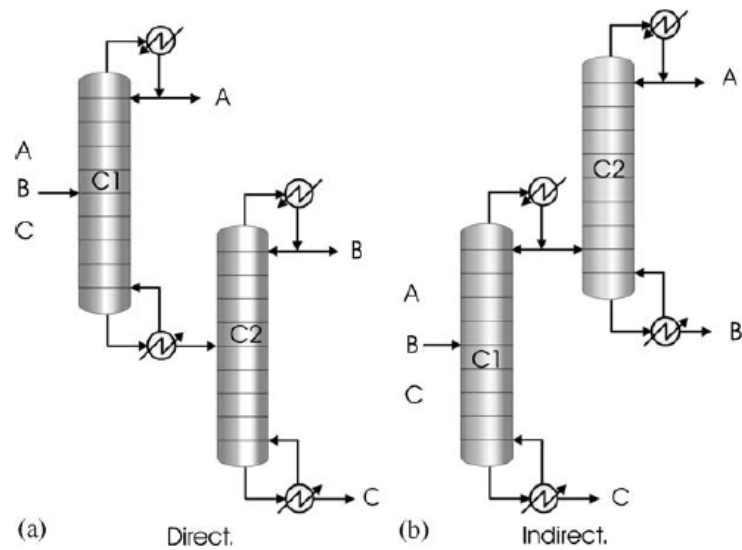

Figure 3.5 Conventional distillation sequences for the separation of ternary mixtures. (Hernandez et al., 2003)

3.5.2 Heat integrated – thermally coupled distillation sequences

It is known that distillation will be used for the separation of approximately 95% of the liquids separations in the chemical industry, and about 3% of the total energy use in the world is used in distillation process (Engelien et al., 2003). Motivated by the enormous demand of energy in distillation processes, researchers have developed new arrangements that can savings in both energy and capital costs (Kaibel et al., 2002). One technique used to reduce the energy consumption in distillation column is the thermally coupled distillation sequences (TCDS), which can save energy up to 30 - 50% in contrast to the direct and indirect distillation column for the separation of ternary mixtures.

From the three TCDS shown in Fig. 3.6, the mainly energy efficient design is the Petlyuk column, which can achieve energy savings of up to 50% in contrast to the conventional distillation column (Hernandez and Jimenez, 1999). The main problem encountered in the Petlyuk column is concerned with the two directions of flow in the vapor streams.

According to Fig. 3.6a a rectifier is thermally connected to the main column. This coupled column uses one reboiler to generate the vapor for both the columns but two condensers for liquid rectification. The total system has to operate at the same pressure. However the pressure in the main column is slightly higher than that in the rectifier to accommodate for the natural flow of vapor. The system is similar to the side rectifier likely the side stripper. The difference being that in this arrangement there are two reboilers and only one condenser. In this case, the stripping operated at a slightly higher pressure for natural vapor flow to occur. According to Fig. 3.6c, the vapor stream AB that removes on the top of the prefractionator must have higher pressure than the main column in order to put into it. Also, the pressure in the recycled vapor stream from the main column to the bottoms of the prefractionator should be higher than that of the bottoms of the prefractionator. This cannot occur in a natural form. It requires the use of a compressor to adjust the pressure of one stream.

Documents related to single distillation columns; for the reason that the main support of this research is to present the analysis of thermodynamic efficiencies of the alternative configuration to the Petlyuk column shown in Fig. 3.6c. The Petlyuk distillation column is helpful because can be managed in a single shell reduce both energy and capital costs. Saving energy and capital cost about 30% are obtained with this column.

Scope for the integration of conventional distillation columns into an overall process is often restricted. Practical limited often prevent integration of columns with the rest of the process. If the column that cannot integrate with the rest of the process or if the potential for integration is limited by the flows of heat in the background process and then attention must be turned back to the distillation operation itself and complex arrangements considered.

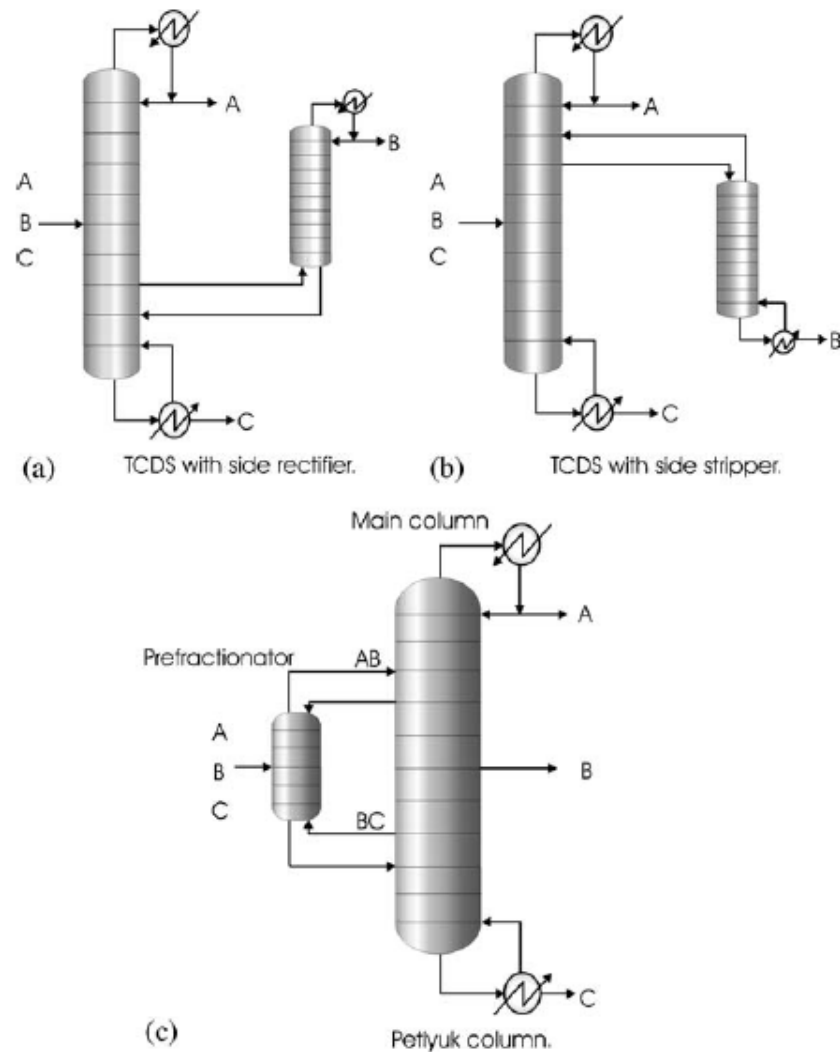

Figure 3.6 TCDS for the separation of ternary mixtures. (Hernandez et al., 2003).

3.6 Aspen plus

Aspen Plus is a component of the Aspen Engineering Suite. It is an integrated set of products designed specifically to promote best engineering practices and to optimize and automate the entire innovation and engineering workflow process throughout the plant and across the enterprise. Automatically integrate process models with engineering knowledge databases, investment analyses, production optimization and numerous other business processes. Aspen Plus contains data, properties, unit operation models, built-in defaults, reports and other features. Its capabilities

developed for specific industrial applications, such as petroleum simulation. Aspen Plus is easy to use, powerful, flexible, process engineering tool for the design and steady-state simulation and optimization of process plants. Aspen Plus process simulation can predict the behavior of a process using basic engineering relationships such as mass and energy balances, phase and chemical equilibrium, and reaction kinetic. Given reliable thermodynamic data, realistic operating conditions and the rigorous Aspen Plus equipment models, actual plant behavior can be simulated. Aspen Plus can help design better plants and increase profitability in existing plants.

3.6.1 Benefits of aspen plus

1. Proven track record of providing substantial economic benefits throughout the manufacturing life cycle of a process, from R&D through engineering and into production.

2. Allows users to leverage and combine the power of sequential modular and equation-oriented techniques in a single product, potentially reducing computation times by an order of magnitude while at the same increasing the functionality and suability of the process model.

3. Compete effectively in an exacting environment, to remain competitive in today's process industries it is necessary to do more, often with smaller staffs and more complex process.

CHAPTER IV

REACTIVE DISTILLATION FOR TRIACETIN PRODUCTION

4.1 Simulation of reactive distillation for triacetin production

In this section, the synthesis of triacetin from esterification of pure acetic acid (100 wt%) with glycerol in a reactive distillation is investigated. The effect of operating parameter on the performance of the reactive distillation for triacetin production is presented. To analyze the triacetin production process, simulations of a reactive distillation was performed based on the RADFRAC module of Aspen Plus (Figure 4-1). A total condenser and a partial reboiler are used. The UNIFAC method was employ to predict thermodynamic properties of substances in the system. The kinetic rate for the production of triacetin in the liquid phase is use from the data of Maria-Isabel et al., (2009). The reactive distillation column at standard condition consists of 20 stages, including a total condenser and a partial reboiler; the numbering of the stages is top downward, column pressure is 1 atm. The acetic acid and glycerol are fed on stages 3 and 2, respectively. All the stages are reactive stages.

All system performances were considered in terms of conversion of glycerol (X_{glycerol}), and yield of triacetin ($Y_{\text{triacetin}}$) defined as follows;

$$(X_{\text{glycerol}}) = \frac{\text{Difference in molar flow rate of inlet and outlet of glycerol}}{\text{Molar feed flow rate of glycerol}} \times 100 \quad (4.1)$$

$$(Y_{\text{triacetin}}) = \frac{\text{Molar flow rate of outlet of triacetin}}{\text{Molar feed flow rate of glycerol}} \times 100 \quad (4.2)$$

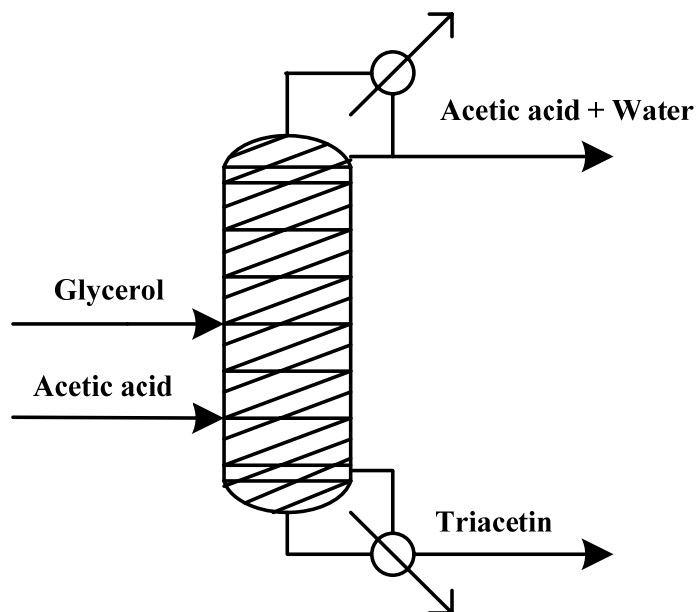

Fig.4-1 Single reactive distillation system for triacetin production

Due to the limitations and constraints in the experimental, some of the key design parameters such as reactive stages, mole ratio of the reactants, reflux ratio, feed stage location feed temperature and distillate rate may be studied a long time in the experiment. Therefore, the effect of parameter on the conversion of glycerol needs to be evaluated by simulation. The simulations were based on base case of reactive distillation.

4.1.1 Standard condition

Feed conditions under standard condition are glycerol of 5 kmol/h, acetic acid of 25 kmol/h pressure of 1 atm, reflux ratio of 1.5, distillate rate 25 kmol/h and feed location of the glycerol is 2 and acetic acid is 3, respectively. Because of in order to increase conversion, a molar excess of acetic acid in the region of five times over glycerol is used. Fig.4-2 to 4-3 show the temperature profile and composition profile of the standard condition. It can be seen that at the top of the column has a number of acetic acid and water are 46% and 54%, respectively. At the standard conditions conversion of glycerol is 99% and the yield of triacetin is 81.4%. It can be seen that the composition of the resulting mixture at the top of the column consists mainly of water and acetic acid while the bottom products comprise mostly the triacetin.

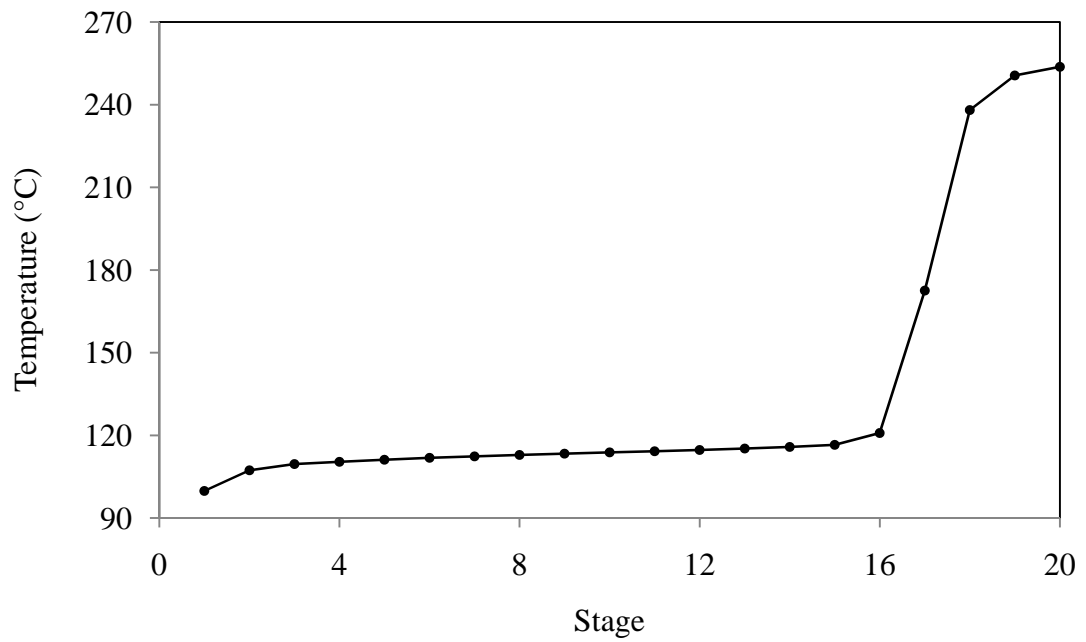

Fig.4-2 Temperature profile at the standard condition

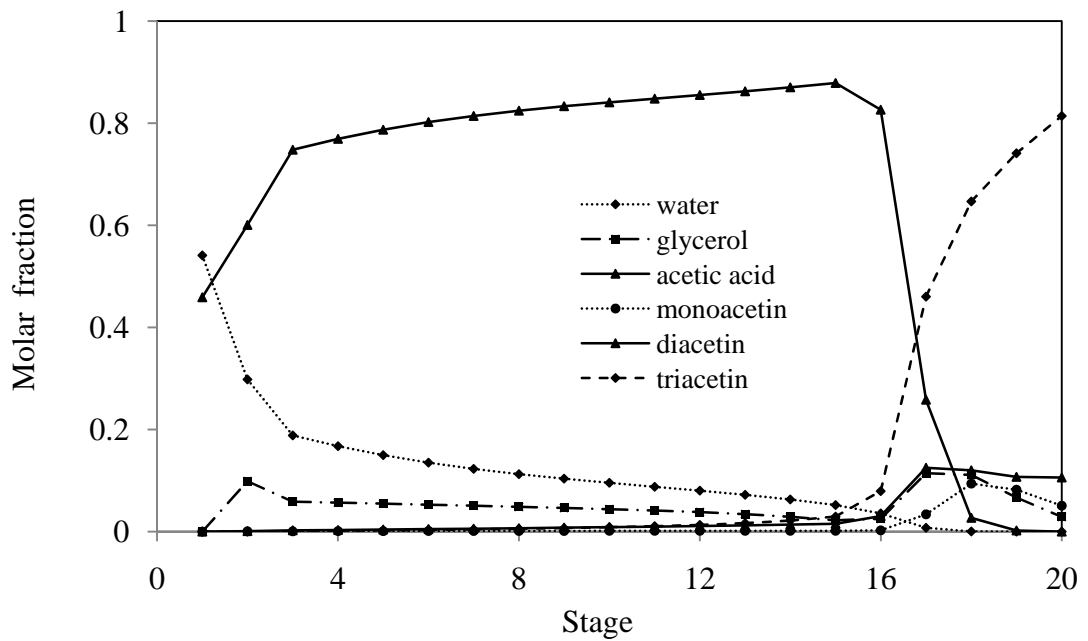

Fig.4-3 Composition profile at standard condition

4.1.2 Effect of reactive stages

Figure 4-4 and 4-5 show the effect of varying the number of reactive stages in the 20 stages. All other variables, including the reflux ratio, distillate rate and feed conditions were fixed. The molar fraction of triacetin increases with an increase in the number of reactive stages from 1 to 20. It is found that the use of the reactive distillation with 17 stages is sufficient to achieved the glycerol conversion of 99.9%. The increase in the number of stages of reaction makes the more separation. In addition, glycerol and acetic acid have more area in contact with each other. Therefore the conversion of glycerol is increased as shown in Figure 4-4 will be seen that the number of stages more than five the conversion of glycerol almost constant. The optimum number of stage give high conversion of glycerol and high yield and purity of triacetin are 17 stages. It is found that 17 stages give a better reactive distillation performance.

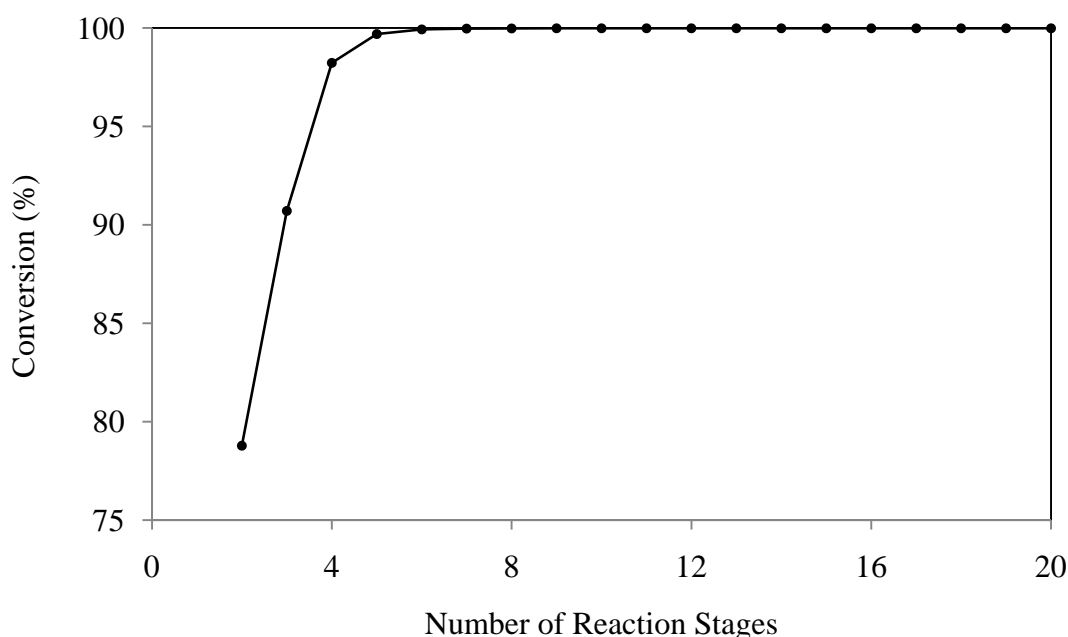

Fig. 4-4 Effect of reaction stage on conversion when molar ratio of 5:1, reflux ratio of 1.5, distillate rate of 25 kmol/h in the reactive distillation

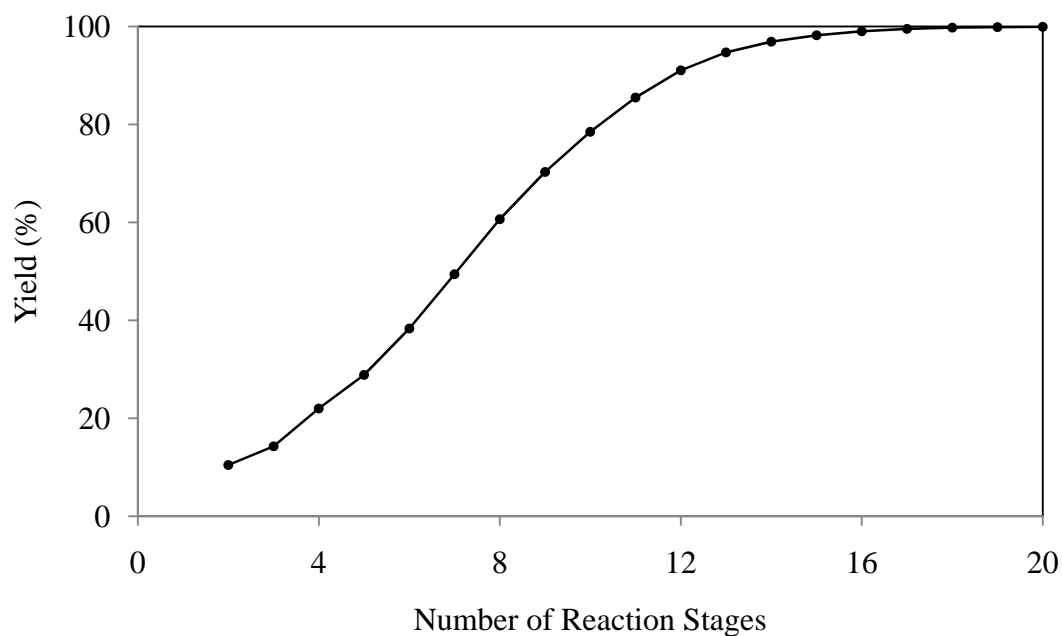

Fig. 4-5 Effect of reaction stage on yield when molar ratio of 5:1, reflux ratio of 1.5, distillate rate of 25 kmol/h in the reactive distillation

4.1.3 Effect molar ratio of acetic acid and glycerol

The mole ratio of the reactants is an important role in determining the conversion and the composition fractions of the top and bottom. The mole ratio of acetic acid to glycerol was studied at 1:1 to 1:10. It can be seen from Fig 4-6 and 4-7 that the conversion of glycerol and the yield of triacetin increase with increasing feed molar ratio. The conversion and yield 99.9% of glycerol was achieved at greater than or equal to 1:6 mole ratio of acetic acid to glycerol. Furthermore the yield of triacetin increased to 99.9% when the mole ratio of acetic acid to glycerol is 1:6. It is obvious that 1:6 mole ratio is optimum and all further simulation were carried out at this mole ratio.

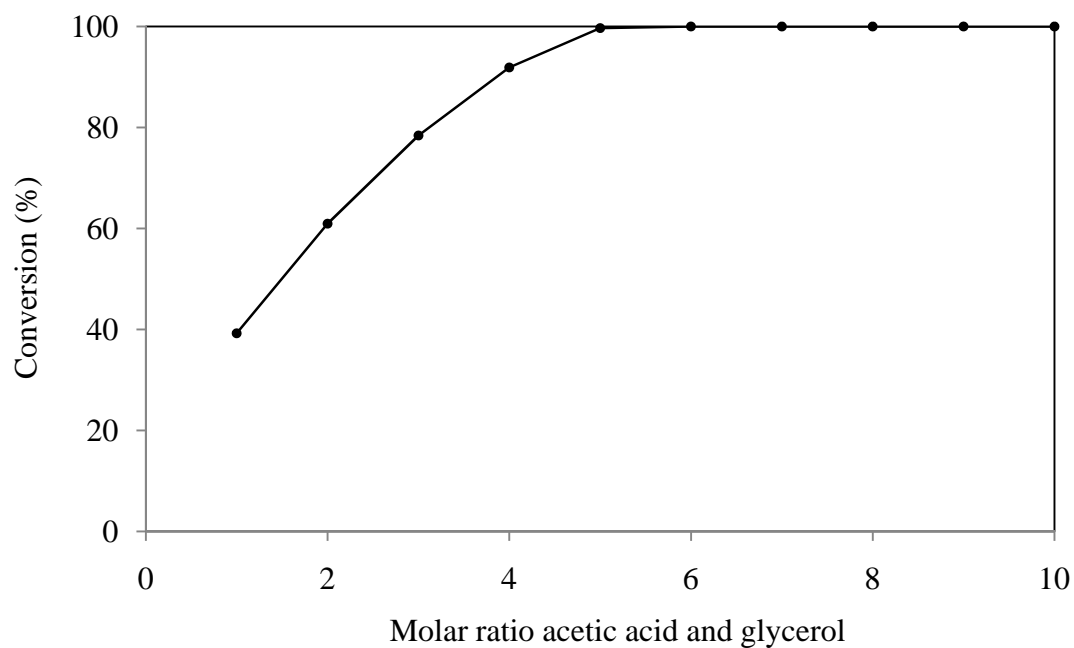

Fig.4-6 Effect of molar ratio of acetic acid and glycerol on the conversion of glycerol in the reactive distillation

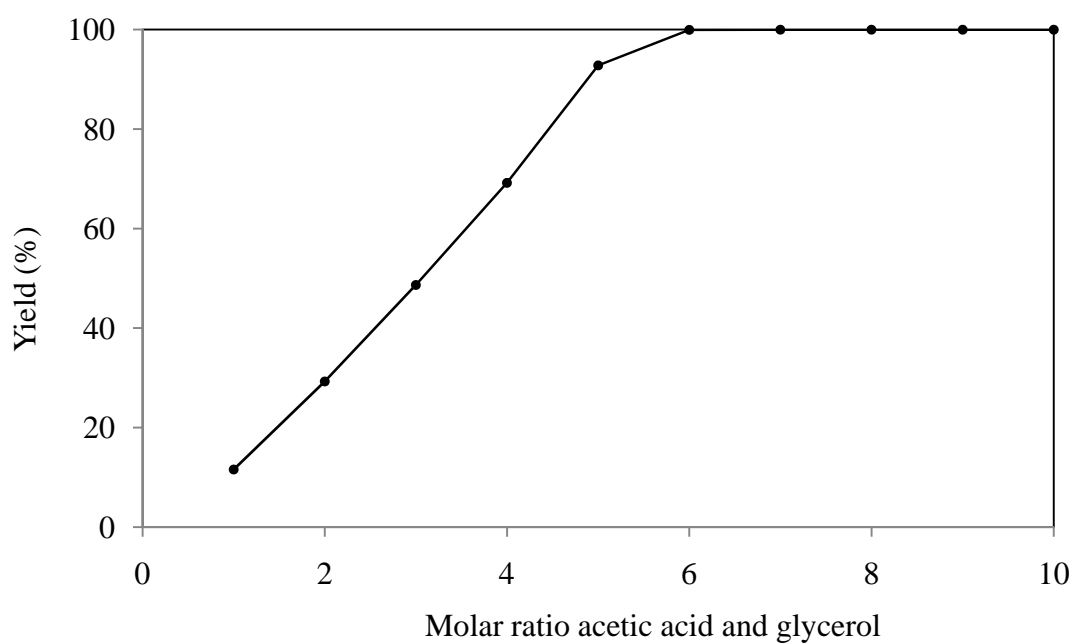

Fig.4-7 Effect of molar ratio of acetic acid and glycerol on the yield of triacetin in the reactive distillation

4.1.4 Effect of reflux ratio

The reflux ratio is important variables that affect the efficiency of reaction and separation in the reactive distillation column. The reflux ratio is significant impact on reaction in the reactive zone and the residence time. The excess of reflux ratio lead to problems in operating conditions and residence time insufficient. The conditions of reactive distillation were fixed as standard case. There is only the reflux ratio has changed from 0.1 to 10 as shown in Figure 4-8 and 4-9. The figures show the results impact of reflux ratio on conversion glycerol and yield of triacetin. From figure 4-8 shows the conversion of glycerol on the rate of reflux ratio increased from 0.1 to 10 which the conversion of glycerol has been changed slightly after the reflux ratio more than two. Notice that the reflux ratio of more than two the yield of triacetin will be greater than 99.9%. This indicates that the increase of reflux ratio result in more separate and the reactant that not react will return to the reaction zone thus increasing the conversion. In addition, when the reflux ratio was increased, the vapor rate increases within the distillation column, which will increase costs in the condenser as shown in figure 4-10 shows the effect of reflux ratio on the condenser duty when increase the reflux ratio will increase condenser duty. Considering the effect of such parameters (conversion glycerol, yield triacetin, condenser duty) the reflux ratio should be conducted at 2.

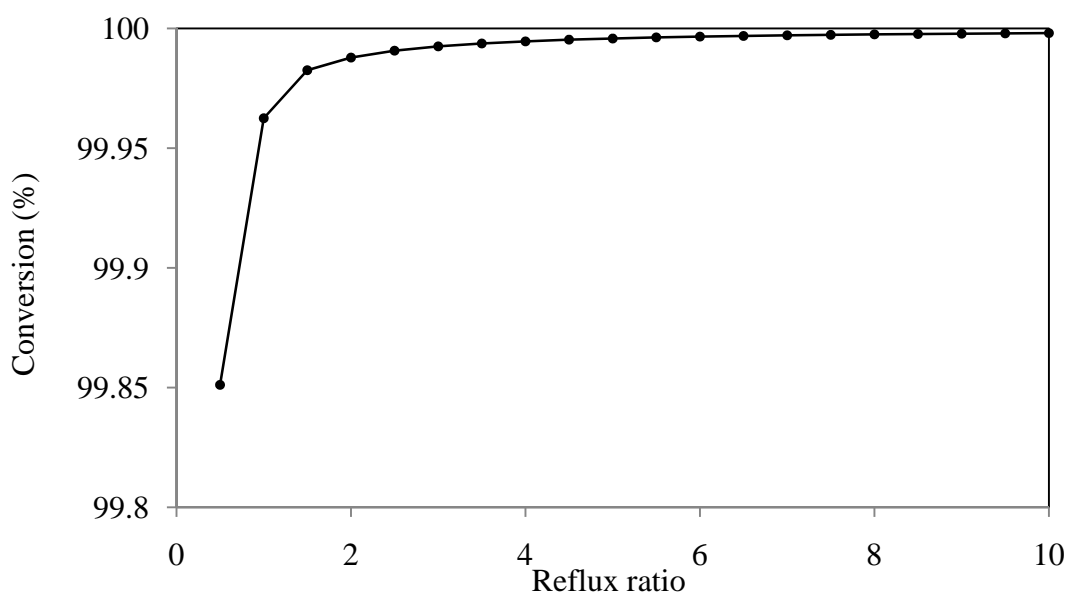

Fig.4-8 Effect of reflux ratio on conversion of glycerol when molar ratio of 5:1, distillate rate of 25 kmol/h in the reactive distillation

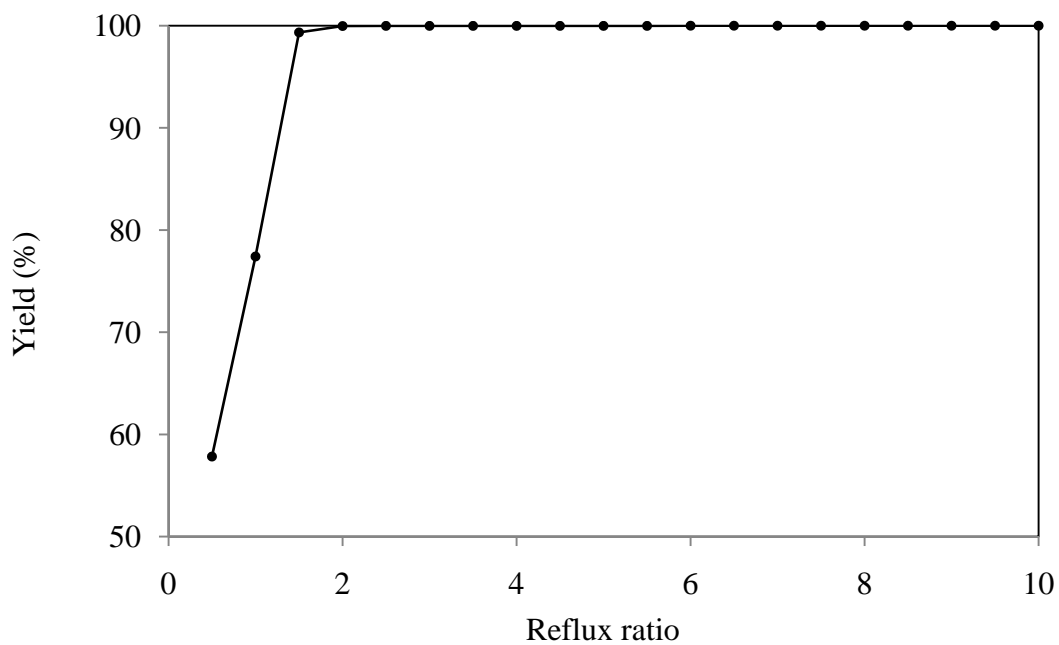

Fig.4-9 Effect of reflux ratio on yield of triacetin when molar ratio of 5:1, distillate rate of 25 kmol/h in the reactive distillation

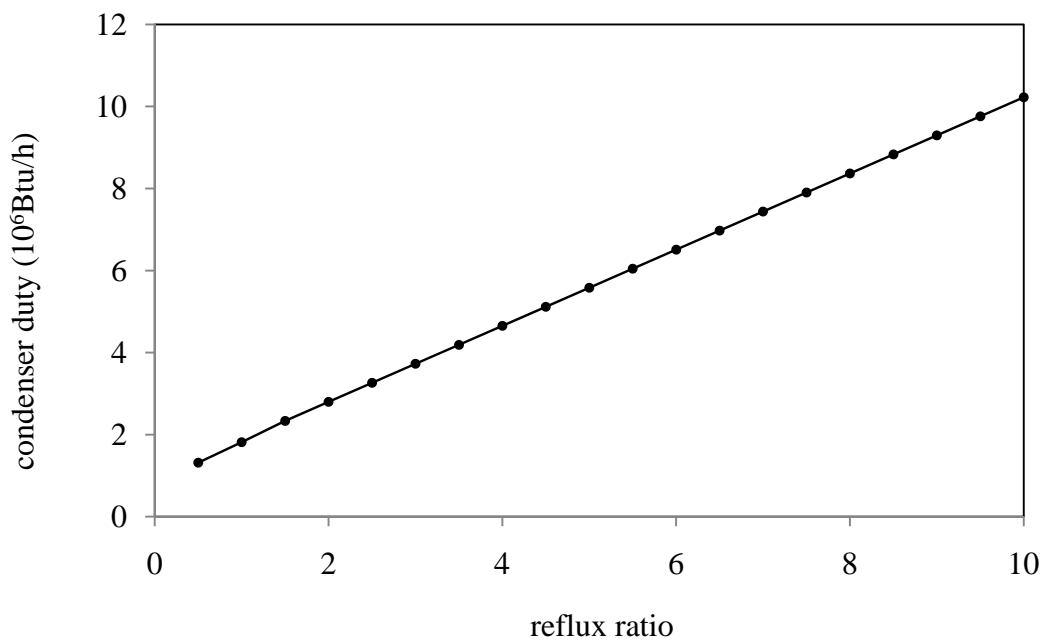

Fig.4-10 Effect of reflux ratio on condenser duty when molar ratio of 5:1, distillate rate of 25 kmol/h in the reactive distillation

4.1.5 Effect of feed stage location

The feed location of acetic acid and glycerol is a very important parameter in the operation of the reactive distillation column. The effect of feed stage location of acetic acid and glycerol on the conversion of glycerol and yield of triacetin in the reactive distillation are shown in Figure 4-11 and 4-12. The feed locations of acetic acid and glycerol at stage 3 and 2, respectively, provide the highest conversion of glycerol and bottom product purity. This indicates that the most effective approach is to feed both the reactants near the top of the column.

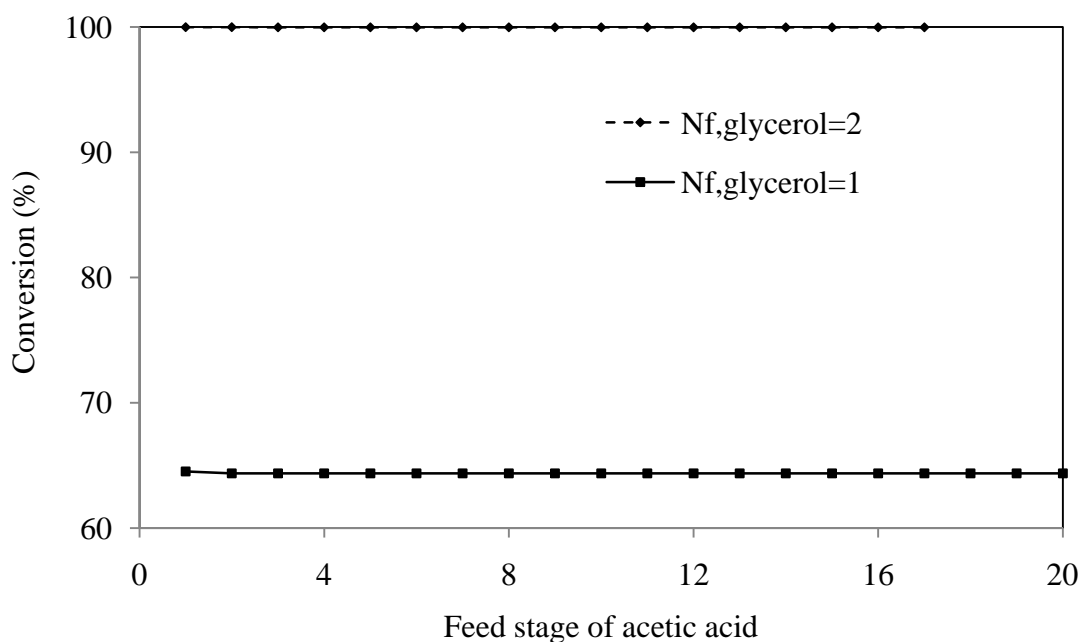

Fig.4-11 Effect of feed stage of acetic acid on conversion when molar ratio of 5:1, reflux ratio of 1.5, distillate rate of 25 kmol/h in the reactive distillation

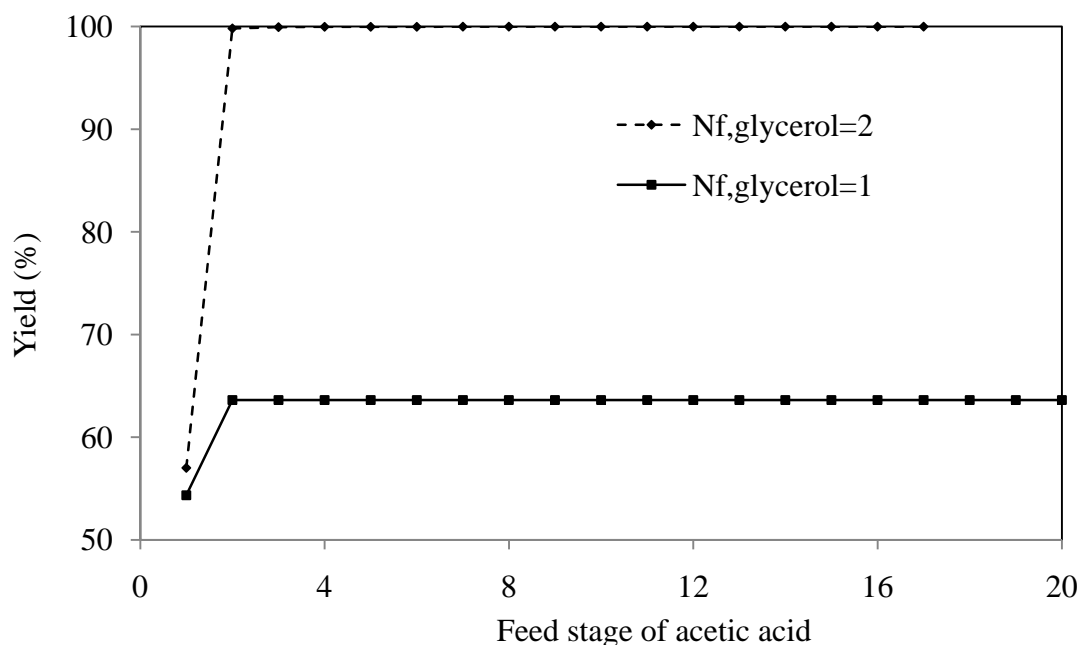

Fig.4-12 Effect of feed stage of acetic acid on yield when molar ratio of 5:1, reflux ratio of 1.5, distillate rate of 25 kmol/h in the reactive distillation

4.1.6 Effect of feed temperature

The effect of feed temperature on the performance of the reactive distillation in terms of conversion glycerol and yield of triacetin are studied. Figures 4-13 show that the conversion of glycerol changed very little when the feed temperature of acetic acid changed between 25 °C to 300 °C but when the feed temperature of glycerol changed it was found that the conversion of glycerol changed very little until it decreased rapidly at temperature over 285 °C. However, from figure 4-14 can be seen that when feed temperatures of glycerol and acetic acid increase from 25°C to 300°C, the yield of triacetin is slightly decreased and dropped suddenly when the temperature of feed glycerol and acetic acid greater than 285 °C and 115 °C, respectively. This caused by a decrease in the amount of glycerol and acetic acid in the reaction section of the column. Basically, the temperature in the reactive distillation column affects both the phase equilibrium and chemical kinetics which at low temperature will result in lower rates of reaction. That requires plenty of liquid holdups in order to have the desired conversion. In contrast, the high temperature will decrease the equilibrium constant cause that will occurred product difficult. Furthermore, at high temperature may promote side reactions that do not need.

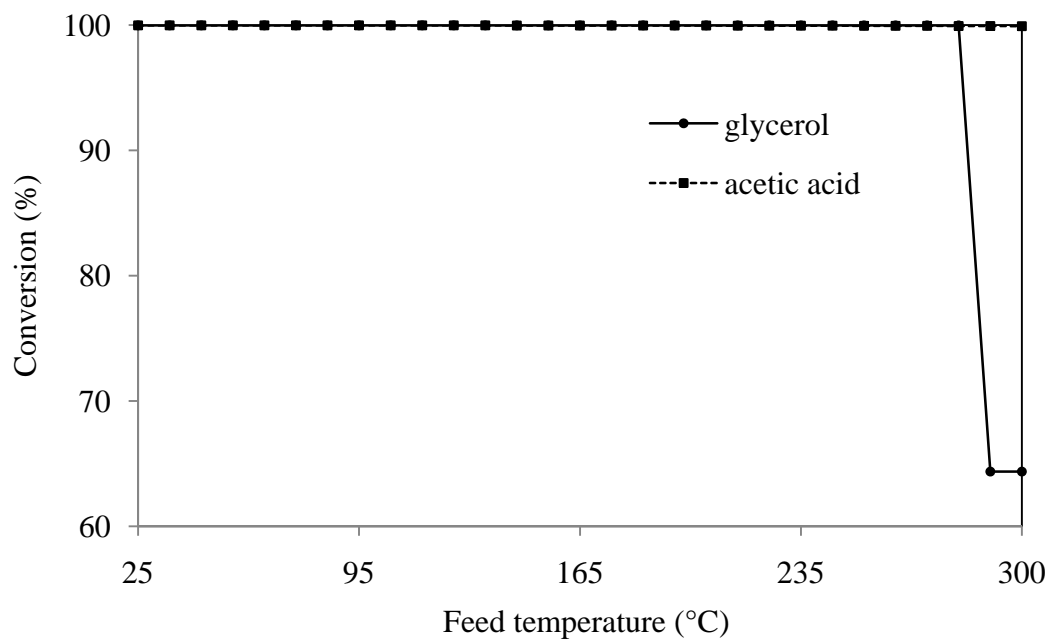

Fig.4-13 Effect of feed temperature of glycerol and acetic acid on the conversion in the reactive distillation

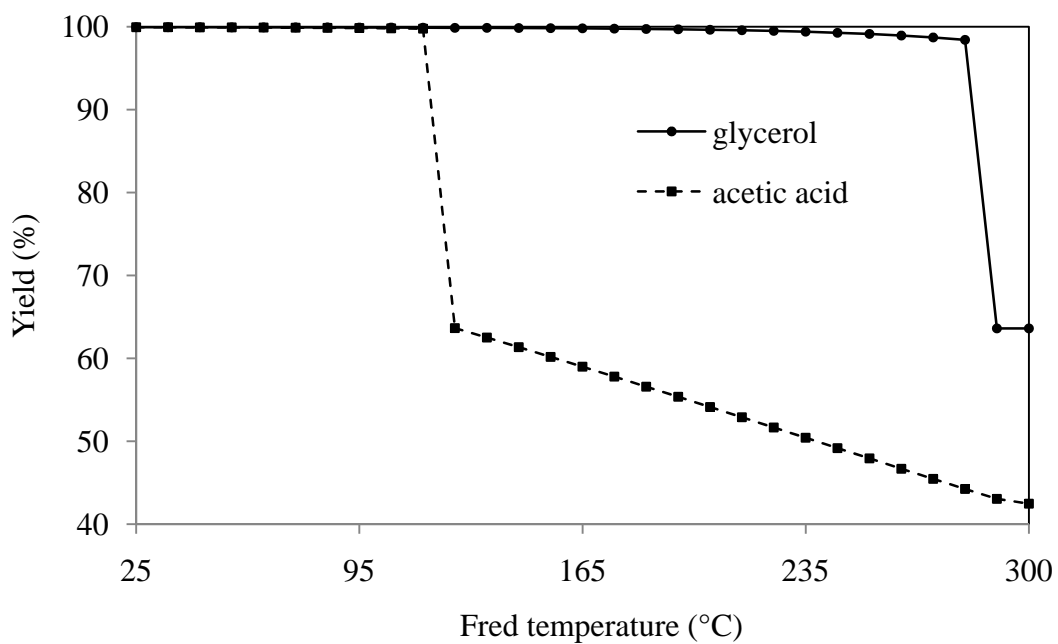

Fig.4-14 Effect of feed temperature of glycerol and acetic acid on the yield in the reactive distillation

4.1.7 Effect of distillate rate

From figure 4.15 shows the analysis of distillate flow rate to determine the bottoms product purities. It can be seen that when distillate flow rate is 30 kmol/h, the molar fraction of triacetin is increasing, but the molar fraction of monoacetin and diacetin at the bottom will have less and decreasing. Figure 4.16 to 4.17 are shown the effect of distillate rate on the conversion of glycerol and yield of triacetin. The operating parameters were the same as the standard condition. It was found that there was an optimum overall feed molar flow rate of offering the highest conversion and yield. From the base case value, increasing feed flow rate increased the yield. However, the conversion will increase the distillate rate more than 26 kmol/h the conversion will be reduced. The increase in flow rate resulted in the decrease in the residence time and column temperature, thus reducing the conversion. Although the higher yield should be expected from the lower column temperature, the opposite trend was observed. However, at the optimum feed flow rate, decreasing feed flow rate decreased the conversion and the selectivity. It was because of the reactants could be easily vaporized and present in the distillate as unconverted reactants.

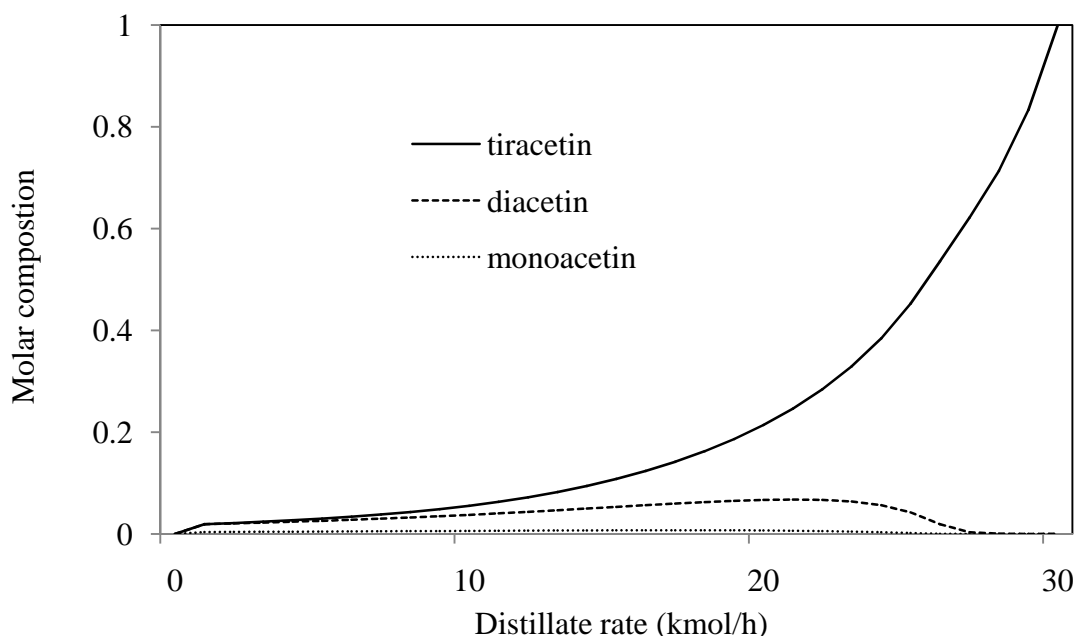

Fig.4-15 Distillate flow rate analysis to determine the bottoms product purities.

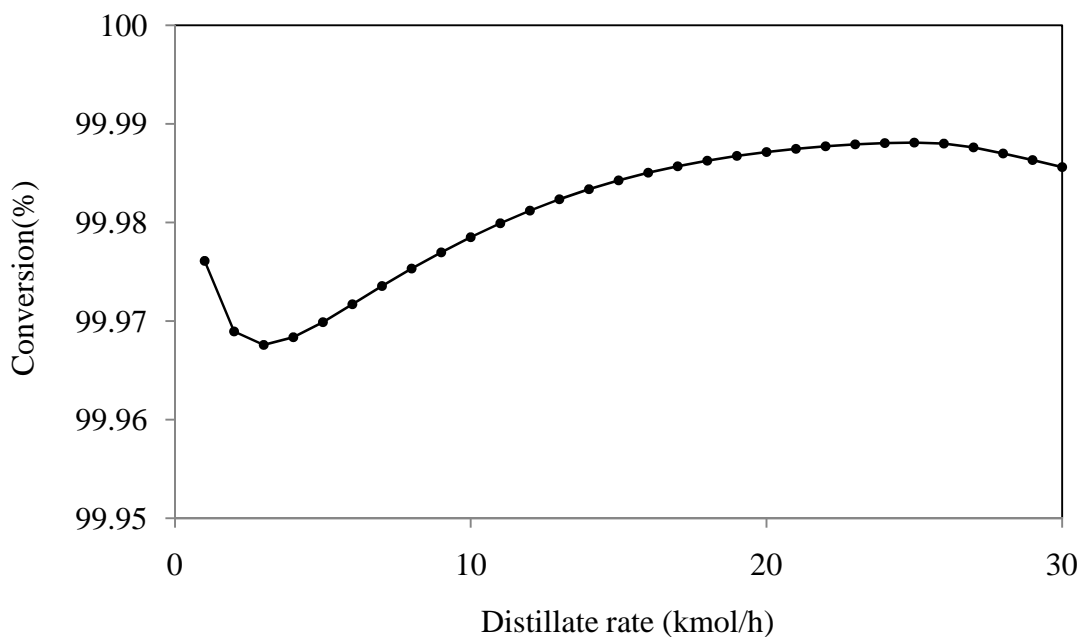

Fig.4-16 Effect of distillate rate on the conversion of glycerol in the reactive distillation

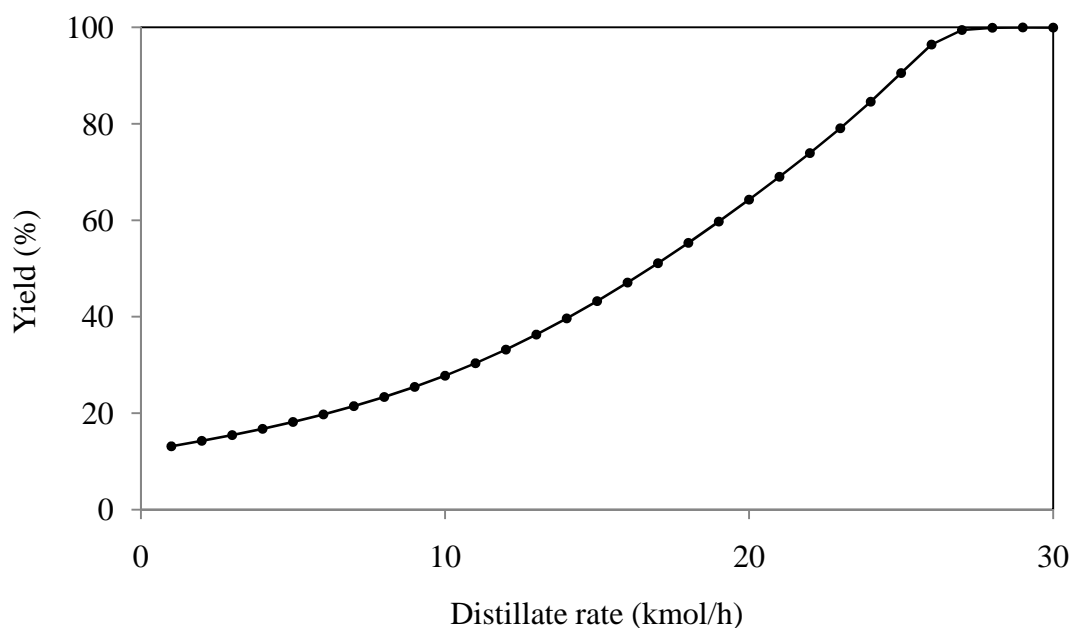

Fig.4-17 Effect of distillate rate on the yield of triacetin in the reactive distillation

From simulation studies, it is found that the optimal configuration for the reactive distillation with molar ratio of 6:1, reflux ratio of 2 and distillate rate 30 kmol/h consists of 17 stages and feed stage of acetic acid and glycerol at stage 3 and

2, respectively. Figure. 4-18 to 4-19 show the typical temperature profile and composition profile in the reactive distillation with the optimal configuration. It can be seen that the composition at the top of column consists of acetic acid and water while the bottom products consists mostly triacetin.

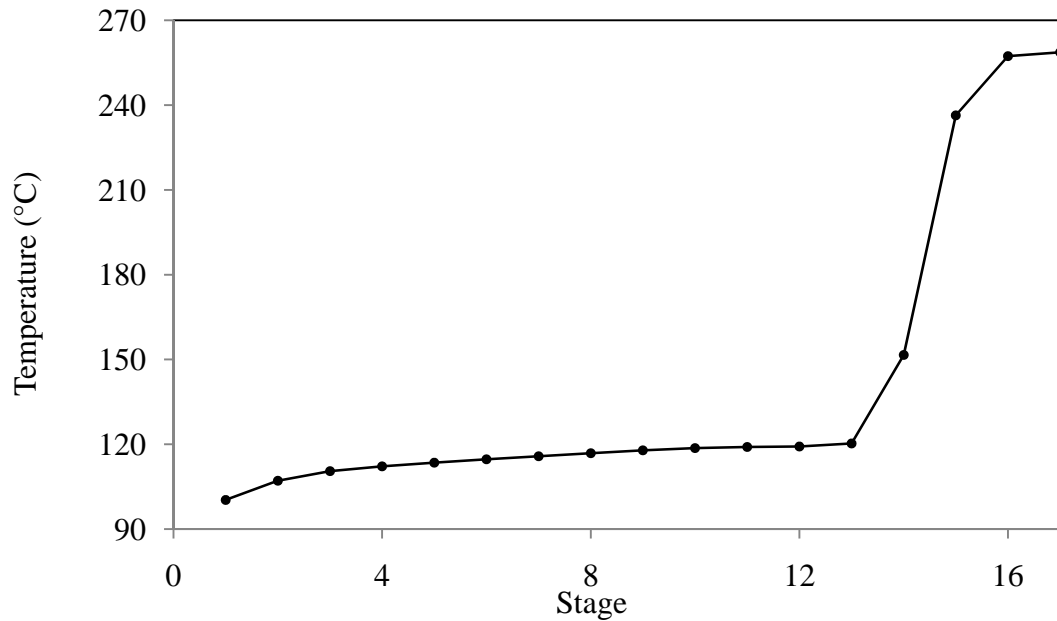

Fig.4-18 Temperature profile in liquid phase along the reactive distillation column (feed temperature of 25 °C, molar ratio of 6:1, reflux ratio of 2 distillate rate 30 kmol/h, stages = 17 stage and feed location of glycerol and acetic at stage 3 and 2, respectively)

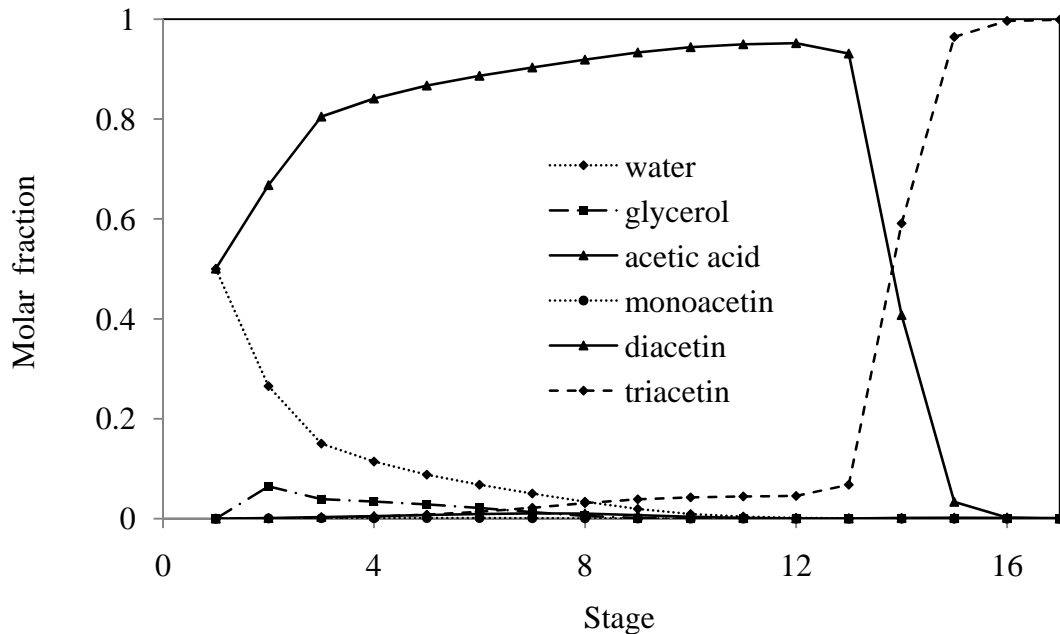

Fig.4-19 Composition profile in liquid phase along the reactive distillation column (feed temperature of 25 °C, molar ratio of 6:1, reflux ratio of 2 distillate rate 30 kmol/h, stages = 17 stage and feed location of glycerol and acetic at stage 3 and 2, respectively)

4.2 Economic evaluation of reactive distillation for triaceticin production

This section is to study the steady-state economic of reactive distillation for triaceticin production. An optimum single reactive distillation for triaceticin production by using the total annual cost as the method is investigated. TAC includes annualized capital cost and operating cost. The annualized capital cost is calculated with the payback period of 3 years and using the cost data in Appendix B of Douglas (1988) book. The column sizing is calculation diameter of column carried out by using the tray sizing in Aspen plus. The distance between trays is kept at 2 ft.

4.2.1 Assumptions and specifications

The specifications and assumptions are made to reduce the number of design optimization variables in the economic steady-state design:

1. The design objective is to obtain 99% conversion.
2. The product purity of the bottom stream is 0.99.

3. In all cases, the molar ratio of acetic acid and glycerol is 6:1.

4. The design specification is to obtain 5 kmol/h of triacetin.

Based on these specifications and simplifying assumptions, there are three variables to optimize the design are as follows:

1. Column pressure P
2. Number of reactive trays
3. Reflux ratio

4.2.2 Determination of an optimum reactive distillation system for the triacetin production

For triacetin production by using reactive distillation, given production rate with product specifications, the design procedure is the following:

1. Fix the column pressure P at a small value (to be varied).
2. Specify the number of the reactive trays (to be varied).
3. The flowrate of the glycerol and acetic acid are fixed at 30 kmol/h and 5 kmol/h, respectively.
4. The flowrate of the bottoms are fixed at 5 kmol/h.
5. Fix the purity of the product in the bottoms and the conversion are 99%.
6. Vary the reflux ratio until the production specification is met.
7. The number of reactive trays is varied over a wide range, and steps 2-6 are repeated for each value of number of reactive trays, generating its corresponding TAC.
8. Finally, the value of the column pressure is changed over a wide range, and steps 2-6 are repeated for each single pressure. The minimum TAC is selected as the optimum economical steady-state design.

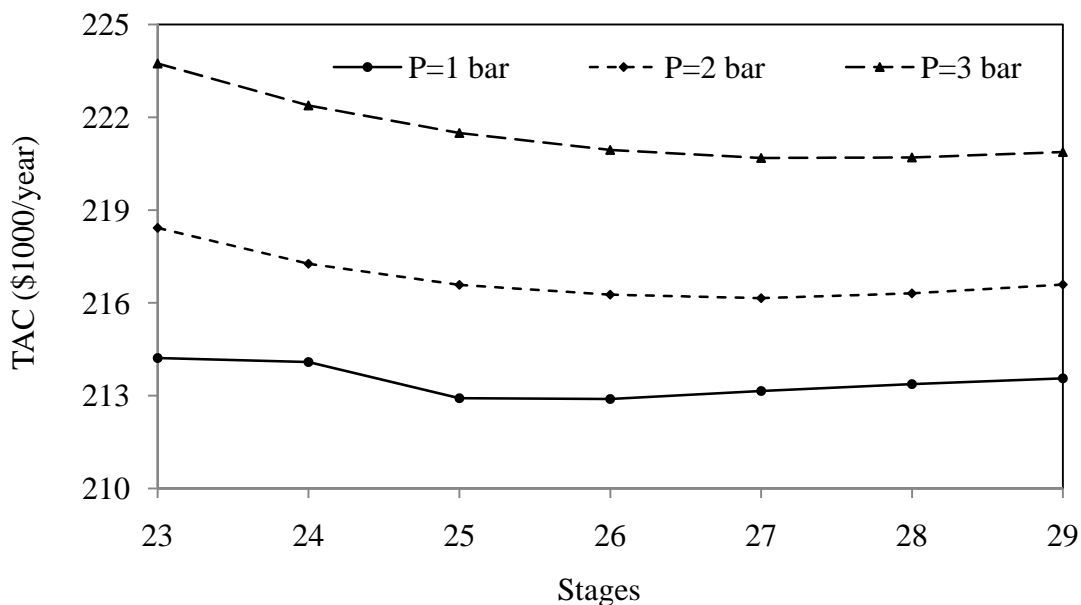

Fig.4-20 Effect the number of reactive stage on total annual cost at different pressures.

Figure 4-20 shows that the number of stage affects on total annual cost at different pressures. At feed location of acetic acid and glycerol at stage 3 and 2, respectively, total annual cost decreases with the increasing number of stage is and then increases at higher values. The optimum stages that minimize total annual cost are 26 stages when the pressure is 1 bar and the appropriate number of stages with the lowest TAC values for the pressure of 2 bar and 3 bar are 27 stages. It can be seen that the more pressure will be more TAC values. The reason for that is the reactive distillation effluent has a higher concentration of reactant glycerol as the reactive stage gets lower. Thus, there is a need for more reboiler heat duty to achieve the desired product specification with less reactive stage. More than 27 reactive stages result in higher capital cost. In addition, increasing reactive stage gives small quantity of glycerol in the distillate stream. This result make high amount of glycerol in the reactive stage, thus increasing the yield of triacetin. From this case, the minimum total annual cost is observed at number of stage was 26. The results reveal that there is a minimum in the total annual cost curve at a certain 26 number of reactive stages for different feed location of glycerol and acetic acid because of the tradeoff between increasing column cost and decreasing energy cost. The simulation results show that the optimum configuration of the single column reactive distillation for triacetin

production from glycerol and acetic acid are number of stages = 26 and feed stage of acetic acid and glycerol at stage 3 and 2, respectively with the value of total annual cost 2.13×10^5 \$/year.

Table 4.1 Sizing and economic of single reactive distillation column for triacetin production (1 bar)

Stage	23	24	25	26	27	28	29
D (ft)	2.54	2.52	2.50	2.48	2.47	2.46	2.45
RR	1.49	1.45	1.42	1.40	1.38	1.36	1.34
Tc (K)	373.43	373.43	373.43	373.43	373.43	373.43	373.43
Tr (K)	531.80	531.80	531.80	531.80	531.80	531.80	531.80
Qc (10^6 Btu/h)	2.33	2.29	2.26	2.24	2.22	2.20	2.19
Qr (10^6 Btu/h)	2.21	2.17	2.15	2.12	2.11	2.09	2.07
Ac (ft ²)	201.81	201.81	196.32	194.35	192.75	191.15	189.54
Ar (ft ²)	491.12	483.31	477.04	472.01	467.90	463.79	459.66
Capital Cost	379085	382701	382732	385349	388326	391199	393963
Operating Cost	87855	86519	85342	84444	83711	82976	82239
TAC (\$/year)	214218	214086	212920	212894	213154	213376	213561

It was clearly demonstrated in Table 4.2 that the summary the details of sizing and economic of single reactive distillation column for triacetin production at pressure 1 bar. Considering the energy requirement at minimum TAC, the overall reboiler heat duties is 2.12×10^6 Btu/h for the single column reactive distillation and the condenser heat duties is 2.24×10^6 Btu/h. The reflux ratio is 1.4 and the reactive distillation column is 2.48 ft diameter. The other columns in Table 4.3 give results for columns with other total stages. If the number of stages is reduced to 25, which gives a shorter column, reboiler heat input increases. This increases column diameter and heat exchanger areas. This results in an increase in both capital and energy costs. If the number of stages is increased, the column becomes taller, but its diameter becomes smaller because reboiler heat input decreases. This will reduce the cost of heat exchanger and energy costs. But the cost of the column increases due to it is longer. Thus, the effect of increasing the number of stages is to increase the capital cost of the shell and to decrease the capital cost of the heat exchangers and energy costs.

CHAPTER V

ENERGY INTEGRATED REACTIVE DISTILLATION COLUMNS

Distillation is one of the most widely used separation methods despite its high energy demands on the reboilers. This process is considerably more energy up to 70% of the overall energy consumption. One alternative used to reduce the demands of energy in the refining sequences is the thermally coupled distillation sequences (TCDS), which can have more energy savings of up to 30% for the separation of multicomponent mixtures in contrast to the conventional direct and indirect distillation sequences trains widely used in the chemical industry.

Thermally coupled distillation systems (TCDS) is a potential energy saving and the separation efficiency technique, especially for separation of azeotrope mixture that is difficult will be separated by conventional distillation. Through the implementation of the interconnection between two columns of vapor-liquid, a condenser or a reboiler of one of the columns is removed, and if a suitable search on the operating conditions is performed, such an interconnection will be able to save energy (Hernandez and Jimenez, 1996).

In this chapter, the design improvement will consider the use of process alternatives or complex column thermally coupled column configurations are modified and discussed. The energy utilization of triacetin production from this arrangement is compared to the reactive distillation with conventional distillation column (indirect sequence) base on the same required spec product. The design and operational parameters are used as input values for the rigorous simulations performed with the RADFRAC model and optimized for the required purity.

5.1 Process of reactive distillation with conventional distillation column (indirect sequence).

The indirect configuration is shown in Figure 5-1. In this arrangement has the transfer of one of the first distillation column to the second distillation column. The first distillation column arrangement, a simple column which has a reboiler and a condenser is used to separate two feed into three products. In this arrangement represents a reactive distillation and a conventional distillation column in which the high-boiling component is taken at the bottom in the first column, the low-boiling component leaves as overhead in the second column and the medium-boiling component accumulates in the bottom of the second column.

In this study, the first column has 17 stages, and the feed of acetic acid and glycerol are introduced on stage 3 and 2, respectively. The column operates at 1 bar. The design specification is to obtain 5 kmol/h of triacetin. The purity of triacetin is assumed at 99.9%. The feed conditions and specification of reactive distillation column and conventional distillation column in this case are shown in Table 5.1.

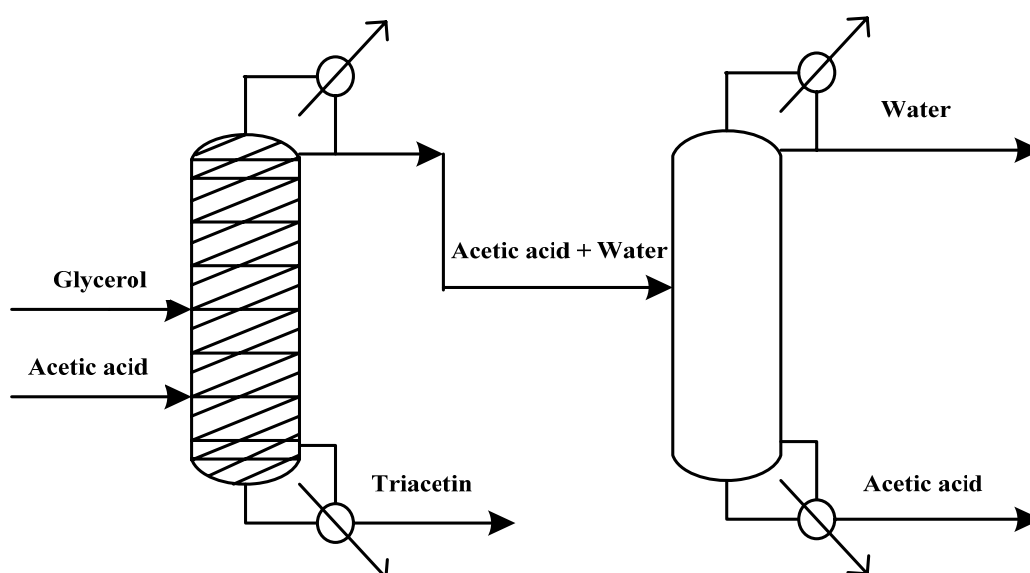

Fig. 5-1 The indirect reactive distillation column with conventional distillation.

Table 5.1 Feed conditions and specification of reactive distillation column and conventional distillation column.

Feed Conditions		Column specification			
		Reactive distillation column		Distillation column	
Temperature (K)	298	Total stages	17	Total stages	17
Pressure (bar)	1	Pressure (bar)	1	Pressure (bar)	1
Flow rate (kmol/h)		Reflux ratio	2	Reflux ratio	1.8
1) acetic acid	40	Bottom rate (kmol/h)	5	Bottom rate (kmol/h)	15
2) glycerol	5	Feed location		Feed location	
Mole fraction		1) acetic acid	3	1) distillate	11
1) acetic acid	1	2) glycerol	2	stream from	
2) glycerol	1			the first	
				column	

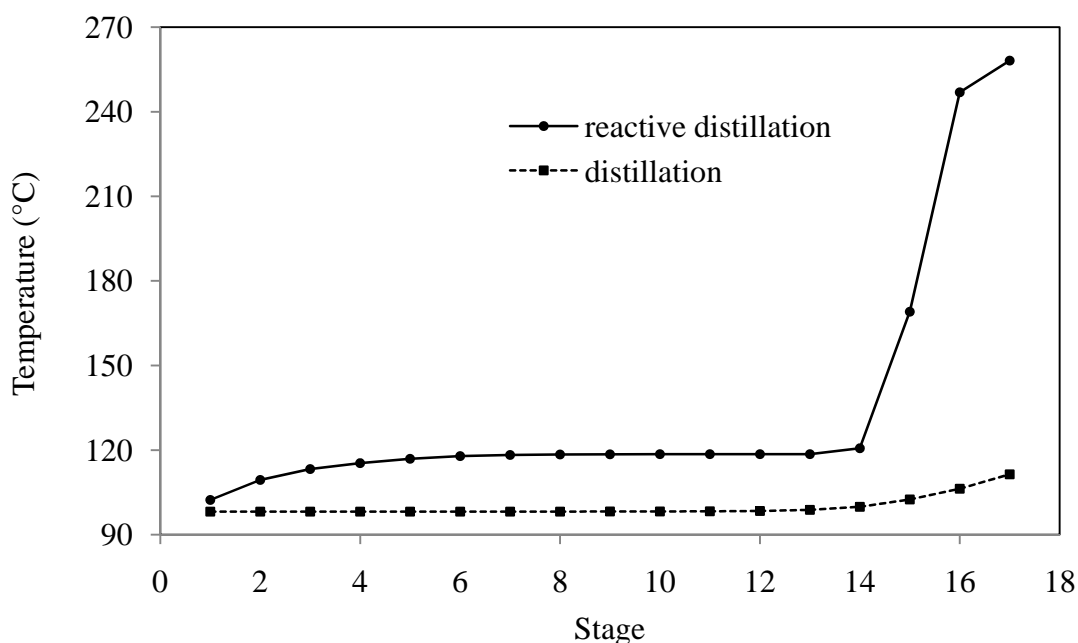

Fig. 5-2 Temperature profile in the design of the reactive distillation column and conventional distillation column.

The graph in Figure 5-2 gives the temperature profile at design conditions. It should be noted that stages are numbered from the top of the column. From this graph presents the temperature profiles of both columns in the reactive distillation column

and conventional distillation column. This temperature profiles can be used to identify the optimal location of the sensors of temperature. It should be remembered that these are steady-state results and nothing about dynamics. Temperatures on all trays in the column are affected more quickly by changing the heat input, so coupling heat input with any tray temperature is going to be dynamic. In the reactive distillation column there was also a large change occurred on stage 14 near the bottom of the column, which is due to the buildup of the heavier than heavy key component triacetin. However, the conventional distillation column was slightly increased when the number of stage increased.

The composition profile of the first column in the reactive distillation column and the second column in the distillation column are shown in Figure 5-3 and Figure 5-4, respectively. It can be seen that the first column in the reactive distillation column at the bottom of the column has a number of triacetin 99.9 %. Figure 5-4 gives the composition profiles of the second column in the distillation column. As a result, it can be observed that at the top of the column has a number of water about 83% and acetic acid is obtained as bottoms product about 90%.

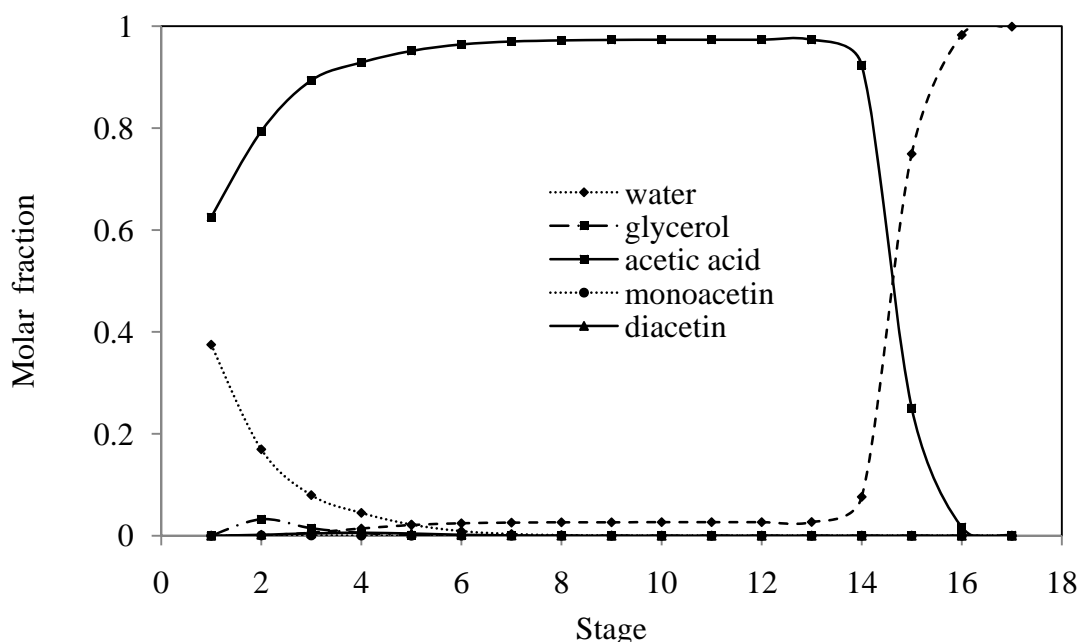

Fig. 5-3 Composition profiles of the first column in the reactive distillation column.

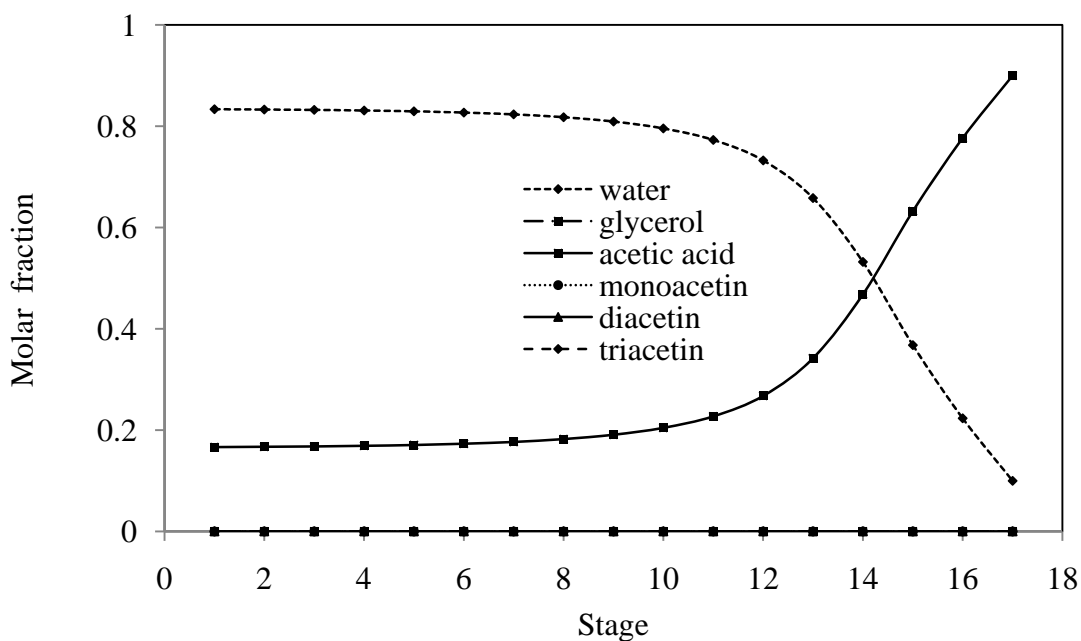

Fig. 5-4 Composition profiles of the second column in the distillation column

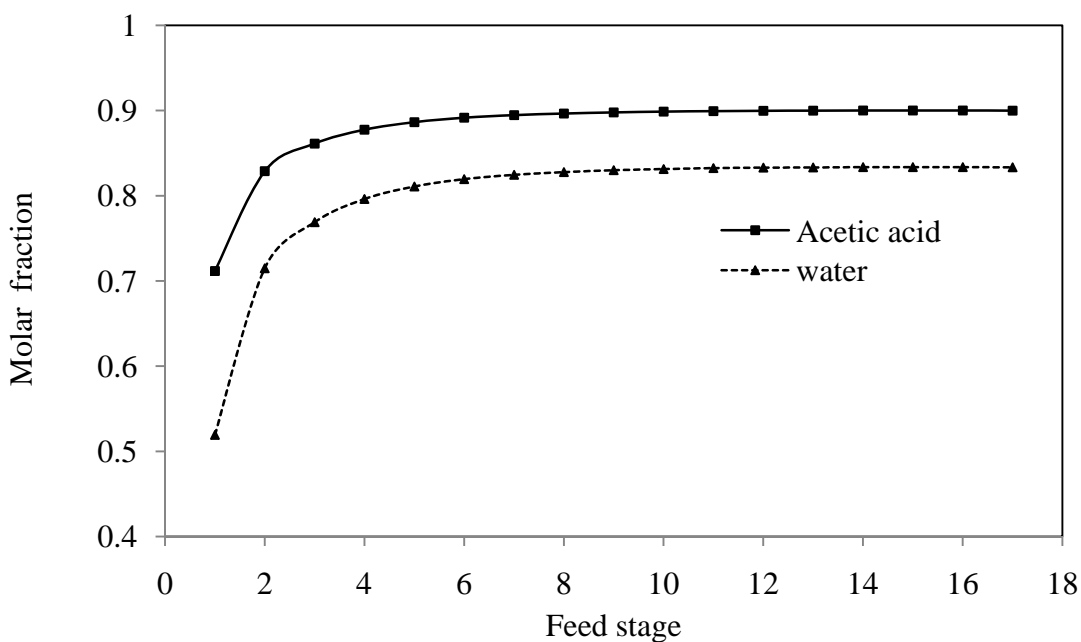

Fig. 5-5 The effect of feed stage location in the distillate stream to the second column on molar fraction of acetic acid and water

Figure 5.5 gives results for varying the feed stage location of distillate stream to the conventional distillation column. The compositions of acetic acid and water are sensitive to feed tray location. The feed stage that high molar fraction of acetic and

water is stage 15, which is very near the bottom of the column. This indicated that the feed location of distillate stream to the second column is an important parameter in the operation of the distillation column.

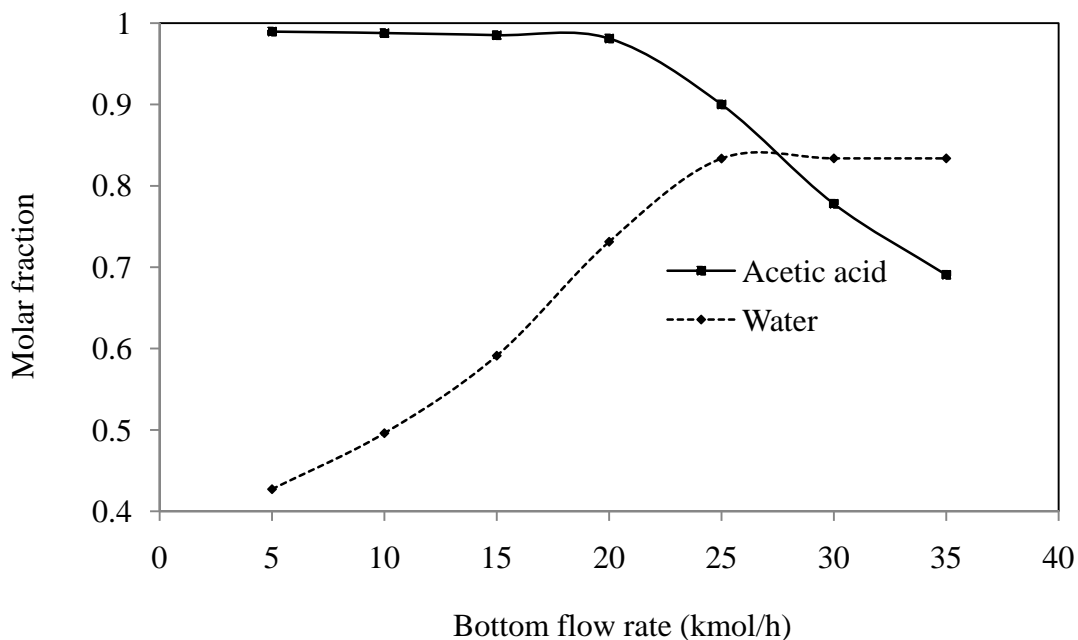

Fig. 5-6 The effect of bottom flow rate in the second column on molar fraction of acetic acid and water.

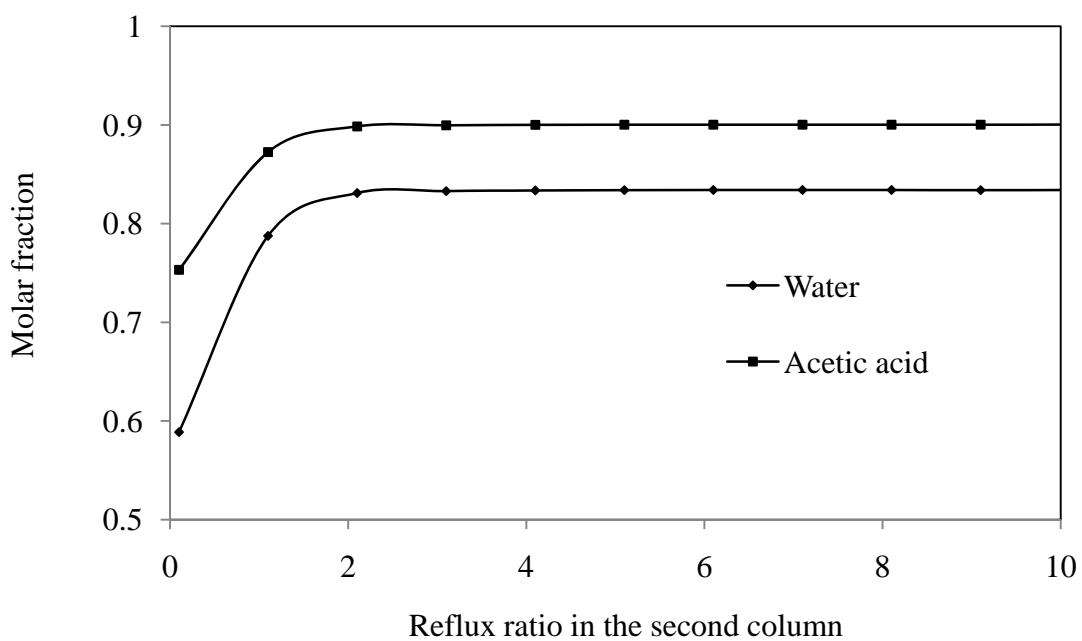

Fig. 5-7 The effect of reflux ratio in the second column on the molar fraction of acetic acid and water

From Figure 5.6 shows the analysis of bottom flow rate to determine the product purities. It can be seen that when bottom flow rate is 25 kmol/h, the molar fraction of water in the distillate stream is increasing but the molar fraction of acetic acid at the bottom will have decreased when bottom flow rate more than 20 kmol/h.

In addition, when the reflux ratio in the second column was increased, the molar fraction of acetic acid and water increased within the distillation column, as shown in Figure 5-7. As a result, it can be seen that when the reflux ratio more than 2 at the top of the column has a number of water about 83% and acetic acid is obtained as bottoms product about 90%.

Table 5.2 Total energy consumption in reactive distillation columns with conventional distillation sequences.

	Condenser Duty (Btu/h)	Reboiler Duty (Btu/h)
Column 1	3.50×10^6	3.43×10^6
Column 2	1.51×10^6	1.53×10^6
Total	5.01×10^6	4.95×10^6

Considering the column performance of the conventional indirect sequence, the total energy consumptions in both condenser and reboiler of each column are shown in Table 5.2. The values will be used as base case values to compare with the design arrangements. In Table 5.2, total energy consumption to achieve a high-purity triacetin is considered, the distillation column in the case of reactive distillation with distillation process are included. From these results, it is found that the total condenser duty and reboiler duty of this arrangement equal to 5.01×10^6 Btu/h and 4.95×10^6 Btu/h, respectively.

5.2 Improving energy consumption in triacetin production with reactive indirect thermally coupled sequence.

In this section, the design of reactive distillation with the heat of thermal coupling for the two columns is studied. The stage numbers of a reactive distillation column and a conventional distillation column remain unchanged in the studied for the processes without thermal coupling to investigate the effect of thermal coupling on energy consumption. The same conditions and specification of reactive distillation column with the thermally coupled (side stripper) are also used. The reactive distillation column with the thermally coupled column configurations (side stripper) is shown in Figure 5-8. It has been shown that it is more beneficial to have two interconnecting streams between the columns-one liquid and one vapor (Agrawal and Fidkowski, 1998).

From conventional indirect sequence, a condenser of the first column is replaced by a thermal coupling but the other conditions, the number of stages and column pressure, are kept at the same values as previous simulation. The bottom rate in both columns and the reflux ratio in distillation column are adjusted to reach the required product purity. The design of the reactive indirect thermally coupled sequence was carried out in two steps: in the first step, adjusted values of stages and interconnecting stages in the two distillation columns. In the second step of the design process, the value of the vapor stream is assumed and a complete search is performed in the liquid stream until the local minimum energy consumption is discovered for the assumed value of the vapor stream.

In this study, the first column has 17 stages, and the feed of acetic acid and glycerol are introduced on stage 3 and 2, respectively. The column operates at 1 bar. The design specification is to obtain 5 kmol/h of triacetin. The purity of triacetin is assumed at 99.9%. The feed conditions and specification of reactive distillation column and conventional distillation column in this case are shown in Table 5.3.

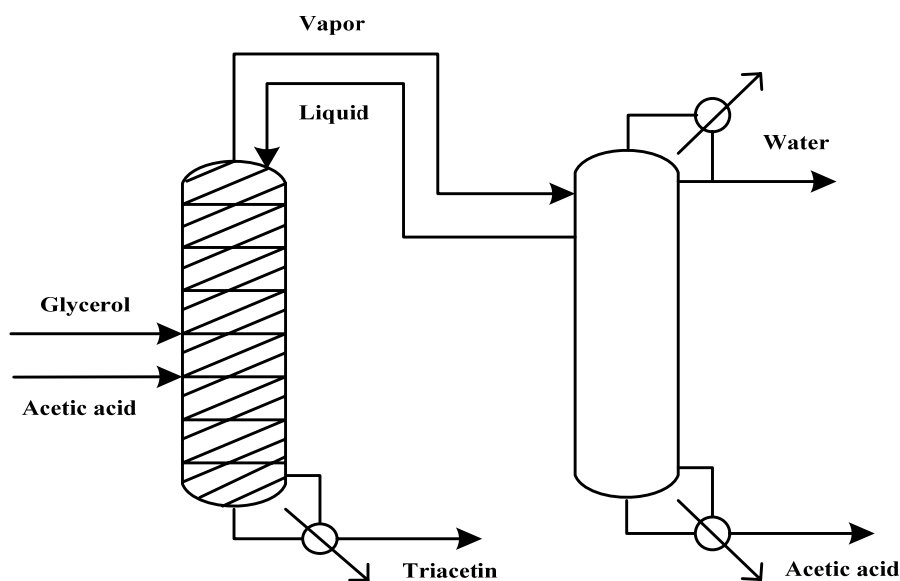

Fig. 5-8 The reactive distillation column with the thermally coupled column configurations (side stripper)

It is important to emphasize that this method is repeated in Aspen Plus until a suitable in terms of number of stages and energy consumption is found. This method can be carried out using mathematical programming. However, the difficulty of the system can lead to rigorous numerical control.

Table 5.3 Feed conditions and specification of reactive distillation column with the thermally coupled (side stripper)

Feed Conditions		Column specification			
		Reactive distillation column		Distillation column	
Temperature (K)	298	Total stages	17	Total stages	17
Pressure (bar)	1	Pressure (bar)	1	Pressure (bar)	1
Flow rate (kmol/h)				Reflux ratio	3.8
1) acetic acid	30	Bottom rate	5	Bottom rate	25
2) glycerol	5	(kmol/h)		(kmol/h)	
Mole fraction		Feed location		Feed location	
1) acetic acid	0.5	1) acetic acid	3	1) vapor stream	13
2) glycerol	0.5	2) glycerol	2	2) liquid stream	12

From Figure 5.9 shows the temperature profile at design conditions. It should be noted that stages are numbered from the top of the column. From this graph presents the temperature profiles of both columns in the reactive distillation column and conventional distillation column. In the reactive distillation column there was also a large change occurred on stage 10. However, the conventional distillation column was slightly increased when the number of stage increased. From this graph has similar to the case of the indirect reactive distillation column with conventional distillation.

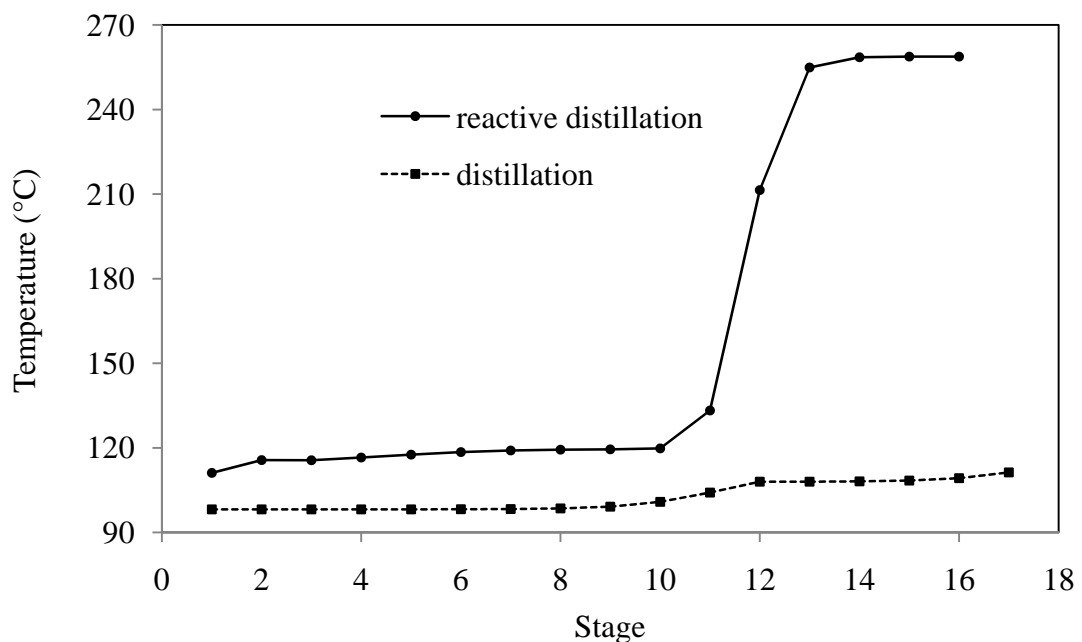

Fig. 5-9 Temperature profile in the design of the reactive distillation column with the thermally coupled (side stripper)

The composition profile of the first column in the reactive distillation column and the second column in the distillation column are shown in Figure 5-10 and Figure 5-11, respectively. It can be seen that the first column in the reactive distillation column at the bottom of the column has a number of triacetin 99.9 %. Figure 5-11 gives the composition profiles of the second column in the distillation column. As a result, it can be observed that at the top of the column has a number of water about 83% and acetic acid is obtained as bottoms product about 90%. From this graph has similar to the case of the indirect reactive distillation column with conventional

distillation. From these results, it is found that the molar fraction of each product from this simulation remained the same as that for the indirect reactive distillation column with conventional distillation case.

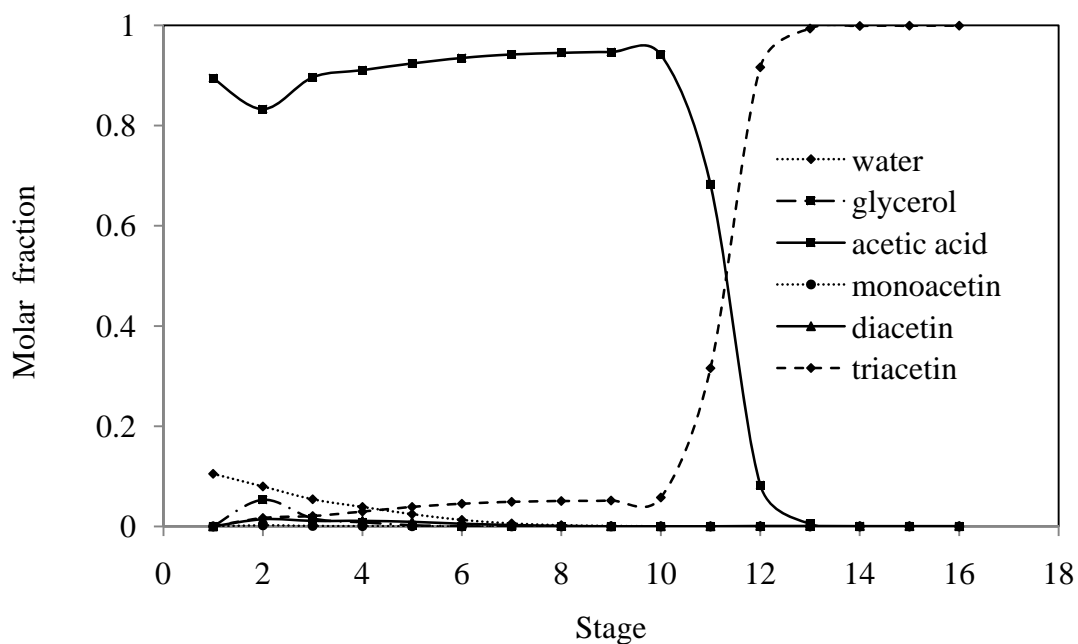

Fig. 5-10 Composition profiles of the first column in the reactive distillation column.

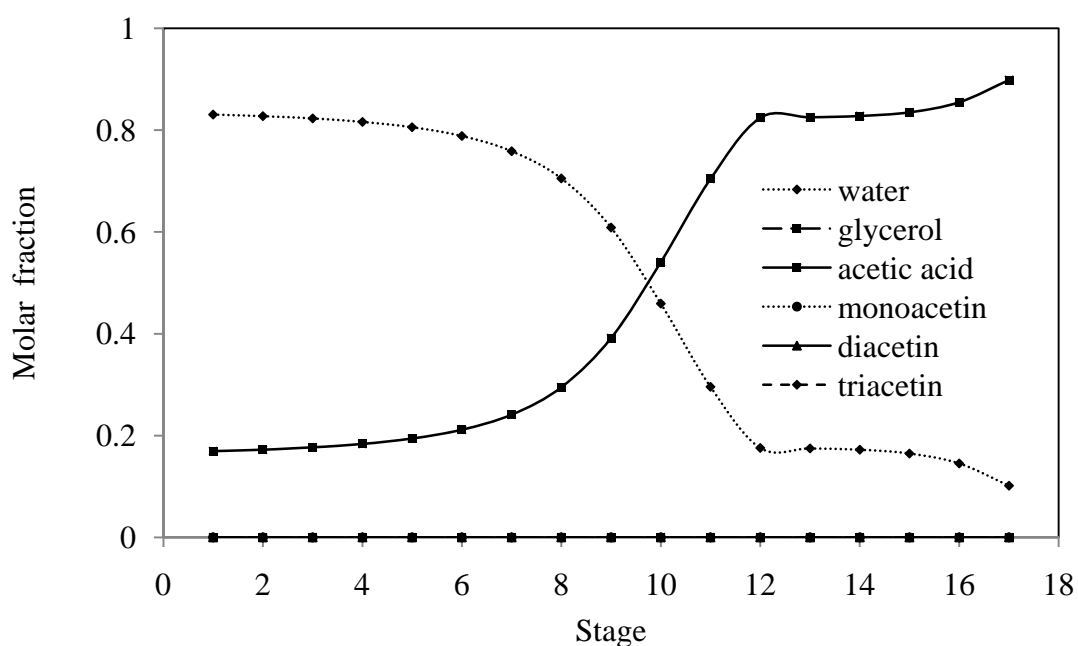

Fig. 5-11 Composition profiles of the second column in the conventional distillation column.

Consider Figure 5-12. This Figure shows different of product stage location in the liquid side stream of the second column on molar fraction of acetic acid, water and triacetin. The molar fraction of water and acetic acid is about 83% and 90%, respectively when stage of side stream at 11. However, the molar fraction of triacetin in the bottom of the reactive distillation is 99.9%, remaining unchanged.

In addition, the effect of feed stage location of vapor stream to the second column on molar fraction of acetic acid, water and triacetin, as shown in Figure 5-13. The molar fraction of water and acetic acid is about 83% and 90%, respectively when stage of vapor stream at 13, while the molar fraction of triacetin in the bottom of the reactive distillation is always higher 99.9%, maintaining unchanged.

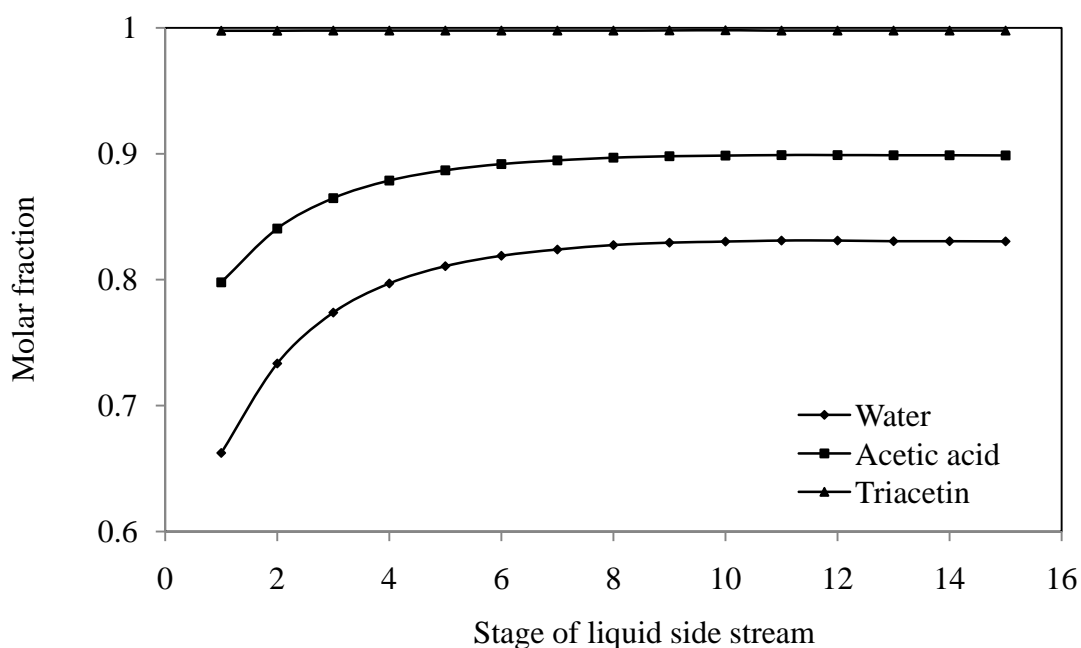

Fig. 5-12 The effect of product stage location in the liquid side stream of the second column on molar fraction of acetic acid, water and triacetin.

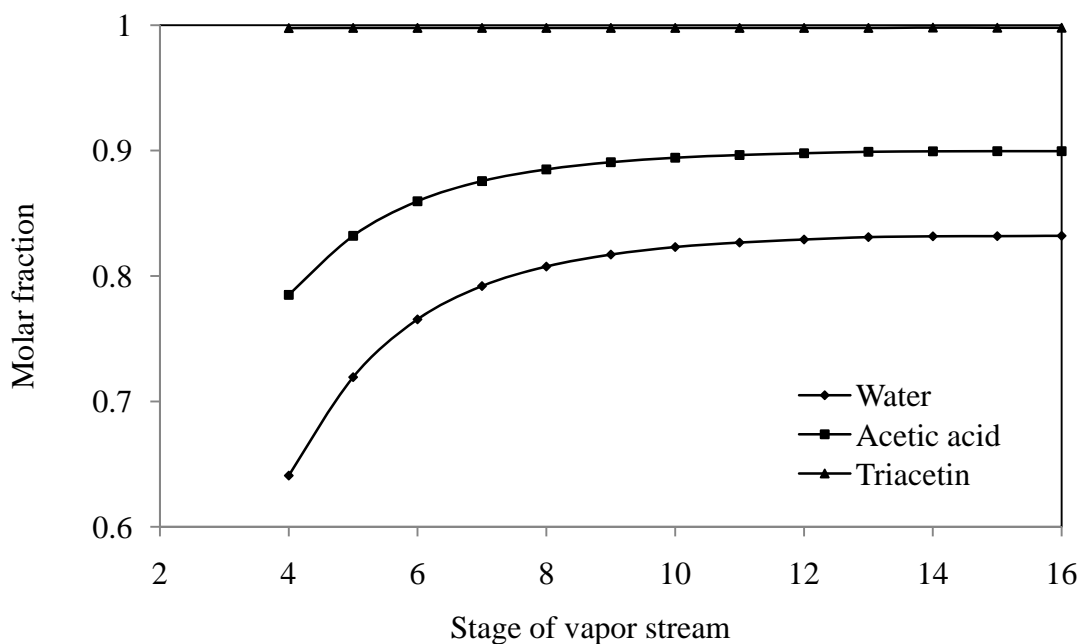

Fig. 5-13 The effect of feed stage location of vapor stream to the second column on molar fraction of acetic acid, water and triacetin.

The effect of mole flow of the side stream in the second column on the mole fraction of acetic acid, water and triacetin, is shown in Figure 5-14. It is found that the molar fraction of triacetin increased with an increased mole flow of side stream. In addition, the molar fraction of water has been changed slightly after the mole flow of side stream more 10 kmol/h. In the other hand, the molar fraction of acetic acid is slightly decreased when the mole flow of side stream increased. Therefore, the optimum number of mole flow give high purity of three products is 30 kmol/h.

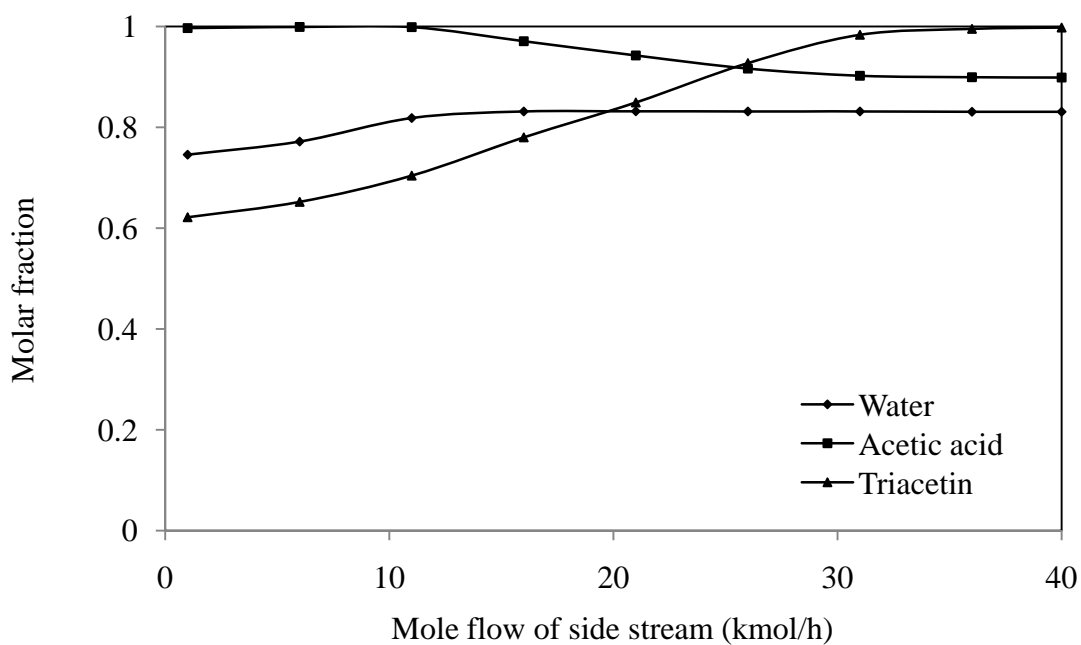

Fig. 5-14 The effect of mole flow of side stream in the second column on the molar fraction of acetic acid, water and triacetin.

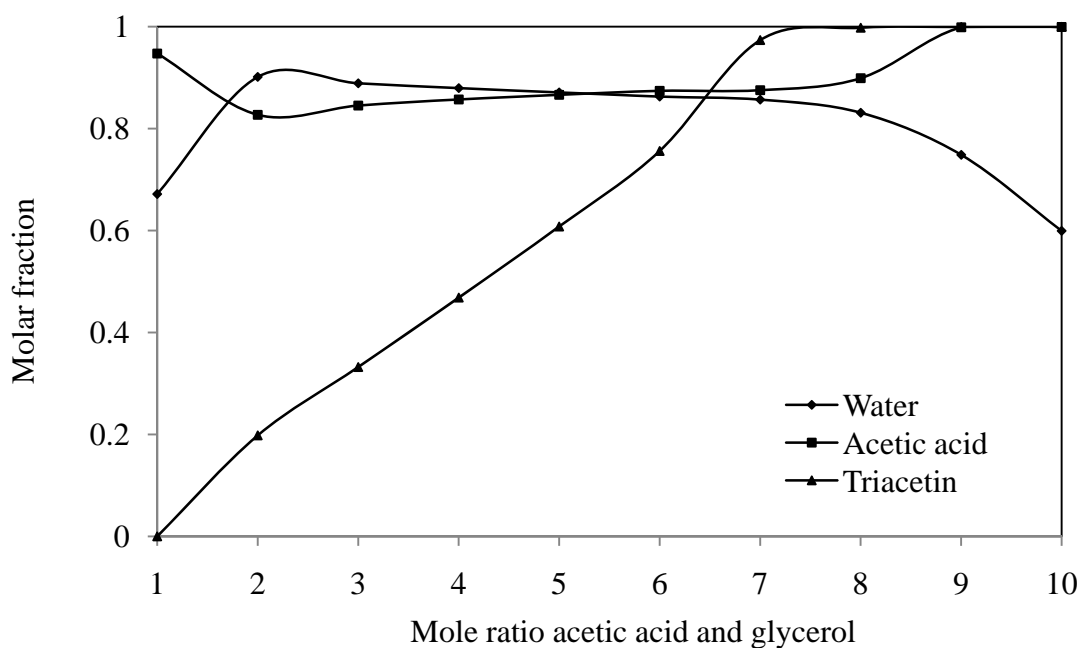

Fig. 5-15 The effect of changing mole ratio of acetic acid and glycerol on the molar fraction of acetic acid, water and triacetin.

The mole ratio of the reactants is an important part in determining the composition fractions of the product at the top and bottom of column. The mole ratio of acetic acid to glycerol was studied at 1:1 to 10:1. It can be seen from Figure 5-15 that the mole fraction of three products increased with increasing feed molar ratio. The high purity of three products was achieved at greater than or equal to 7:1 mole ratio of acetic acid to glycerol.

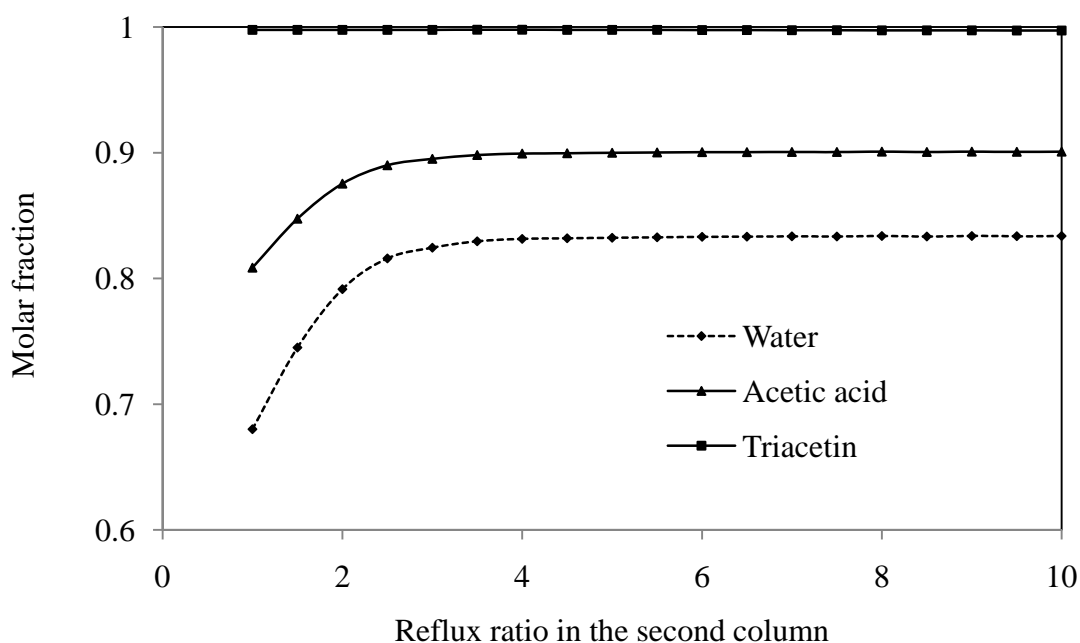

Fig. 5-16 The effect of reflux ratio in the second column on the molar fraction of water, acetic acid and triacetin.

Figure 5-16 shows the changed of the reflux ratio in the second column of the reactive indirect thermally coupled sequence on the molar fraction of three products. The rate of reflux ratio increased from 1 to 10. As a result, it can be seen that when the reflux ratio more than 4 at the top of the column has a number of water about 83% and acetic acid is obtained as bottoms product about 90%, while the molar fraction of triacetin in the bottom of the reactive distillation is always higher 99.9%, remaining unchanged. It is observed from Figure 5-16 that the reflux ratio more than four give higher the molar fraction of three products.

Table 5.4 Total energy consumption in reactive distillation columns with conventional distillation sequences.

	Condenser Duty (Btu/h)	Reboiler Duty (Btu/h)
Column 1	0	2.15×10^6
Column 2	2.60×10^6	3.91×10^5
Total	2.60×10^6	2.54×10^6

From Table 5.4 presents the total energy consumption in both condenser and reboiler of each column in the reactive indirect thermally coupled sequence. In Table 5.4, total energy consumption to achieve a high-purity of three products is considered. It can be seen that the energy consumption depends strongly on the values of the interconnecting streams. Appropriate values of the interconnecting streams are important to obtain the minimum energy consumption in the reactive indirect thermally coupled sequence. After the search for the optimum values of the recycle streams was conducted, values of 40 and 80 kmol/h for the liquid and vapor streams respectively were detected.

From these results, it is found that the total condenser duty and reboiler duty of this arrangement equal to 2.6×10^6 Btu/h and 2.54×10^6 Btu/h, respectively. Also the total condenser duty and reboiler duty of this arrangement is less than that in the case of indirect sequence. This is the result from the reduction of re-mixing effect, which causes the column efficiency to improve.

Considering the column performance of the column with side stripper arrangement, when the condenser of the first column has been replaced by thermal coupling, this condenser heat load is shifted to the condenser of the second column. It is well-known that the thermally coupled distillation column can reduce energy demands between 30 and 50% depending on the composition of the mixture to be separated. In this comparison, the results will be compared in terms of total energy consumption. The energy consumption in complex distillation arrangement will be compared to the conventional indirect sequence. This comparison can be shown in Figure 5-16. From Figure 5-16, it is clearly seen that complex distillation arrangement, which is the reactive indirect thermally coupled sequence can reduce

total energy consumption in condenser and reboiler. In case of the column with side stripper, energy consumption can be reduced by about 48.6%.

CHAPTER VI

REACTIVE DISTILLATION FOR TRIACETIN PRODUCTION FROM CRUDE GLYCEROL

Crude glycerol is the primary by-product of manufacturing biodiesel, has been produced at increasing levels in recent years. It consists of the heavy liquid phase produced as a result of the transesterification of animal fats and vegetable oils, has high impurity content.

For this section, this work investigated the potential of using the crude glycerol to produce triacetin by reactive distillation column. By using the crude glycerol instead of the pure glycerol and studied at three various possible configurations. In this chapter was studied by follow the configuration in chapter 4. Due to the configuration in chapter 5 was design quite difficult and complicated.

6.1 Configuration 1: Direct feed of crude glycerol to a reactive distillation for triacetin production

In general, a composition of crude glycerol depends on the materials and processes used in biodiesel production, a mixture of glycerol and methanol are a major components in the crude glycerol. By-product glycerol often contains up to 50% impurities such as biodiesel & methanol (Norman Tate and Co. Ltd., 2003), a main subject for processing the byproduct of the transesterification reaction. Anand et al., (2010) reported that the crude glycerol produced in the biodiesel process has methanol about 14.5%. Furthermore, Onwudili and Williams (2010) presented the total concentration of methanol and moisture content of the crude glycerol was found to be 27.2 vol.% . However, the main compositions of crude glycerol are glycerol (60

wt.%) and methanol (31 wt.%) (Valliyappan et al., 2008) which were considered in this study is a reactant for triacetin production.

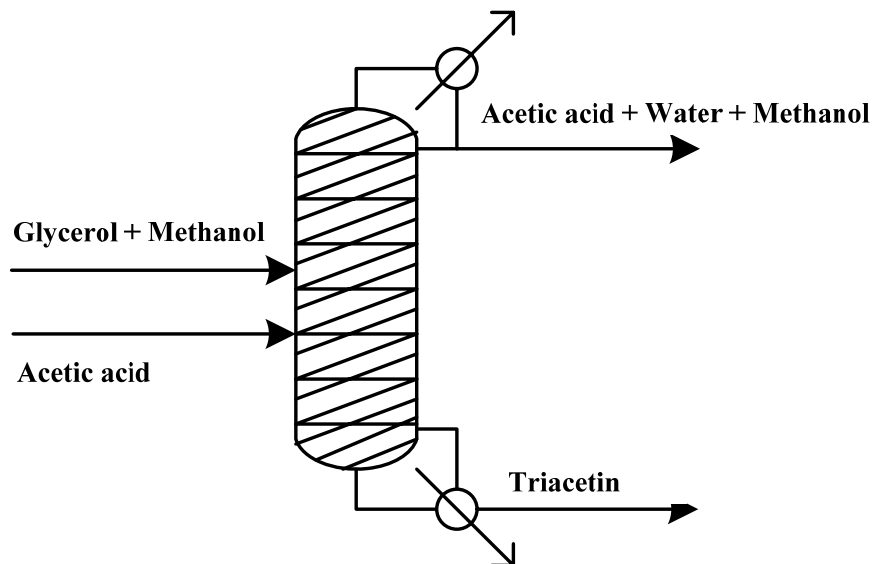

Fig. 6-1 The reactive distillation column by feed a mixture of glycerol and methanol.

In this section at different ratios of glycerol per methanol was used to investigate its effect on the triacetin process by using reactive distillation. Feed conditions in this studied are glycerol of 5 kmol/h, acetic acid of 30 kmol/h pressure of 1 atm, reflux ratio of 2, bottom rate 5 kmol/h and feed location of the glycerol is 2 and acetic acid is 3, respectively as shown the details in Table 6.1. In this studied used a molar excess of acetic acid in the region of six times over glycerol in the feed. The reactive distillation column is produced triacetin at the bottom and allows the water, acetic acid and methanol to collect at the top of the column.

From Fig.6-2 shows the conversion of glycerol and yield of triacetin at different ratios of glycerol per methanol. It can be seen that when increasing the percentage of methanol in glycerol the conversion of glycerol decreased only slightly. Furthermore, the yield of triacetin reduced to 99.85% when methanol is mixed with the glycerol is 30%.

Table 6.1 Feed conditions and specification in reactive distillation column for feed a mixture of glycerol and methanol

Feed conditions		Reactive distillation column	
Temperature (K)	298	Total stages	17
Pressure (bar)	1	Pressure (bar)	1
Flow rate (kmol/h)		Reflux ratio	2
1) acetic acid	30	Bottom rate (kmol/h)	5
2) glycerol	5	Feed location	
Mole fraction		1) acetic acid	3
1) acetic acid	1	2) glycerol	2
2) glycerol+methanol	1		

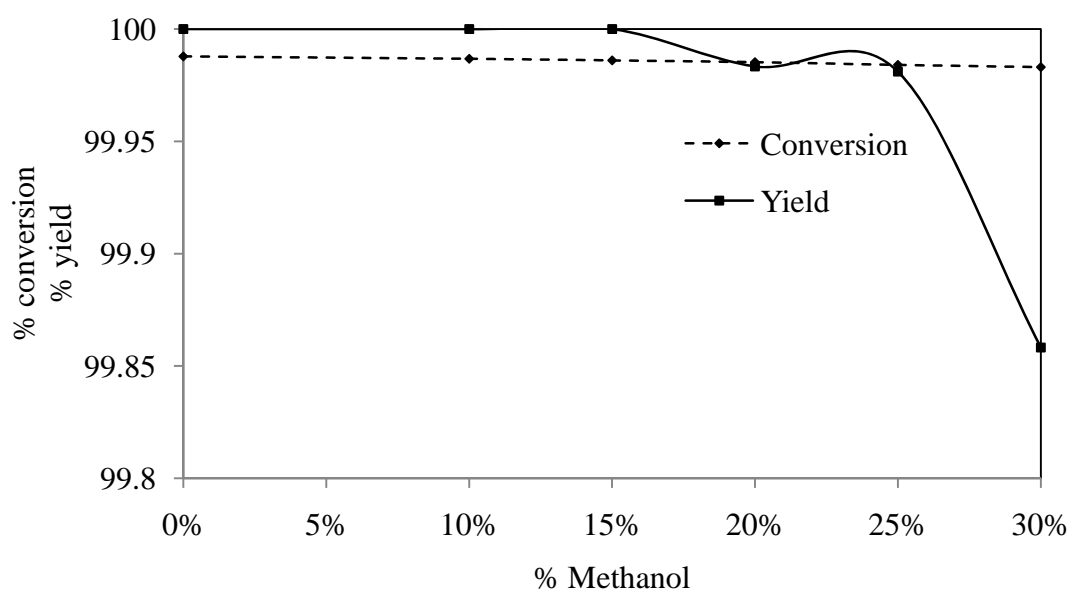

Fig. 6-2 Conversion of glycerol and yield of triacetin at different ratios of glycerol per methanol.

Figure 6-3 shows the effect of increasing the percentage of methanol in glycerol on the molar fraction of main component such as acetic acid, water, methanol

and triacetin. The molar fraction of triacetin at the bottom of column decreases with an increase in the percentage of methanol. In addition, the molar fraction of water at the distillate stream has reduced but the molar fraction of acetic acid increased with an increasing amount of methanol in glycerol. The results indicate that the increase in the percentage of methanol in glycerol makes the product has a molar fraction decrease.

The mole flow rate of the main components in the reactive distillation is shown in Fig. 6-4. It can be seen that the rate of flow of the reactant (acetic acid and methanol) increased while the flow rate of product (water and triacetin) decreased.

The figures 6-5 show the results energy consumption in the reactive distillation columns when increasing the percentage of methanol in glycerol. Considering the total energy consumptions in both condenser and reboiler of each column, it is found that the condenser duty and reboiler duty decrease when increase the percentage of methanol in glycerol.

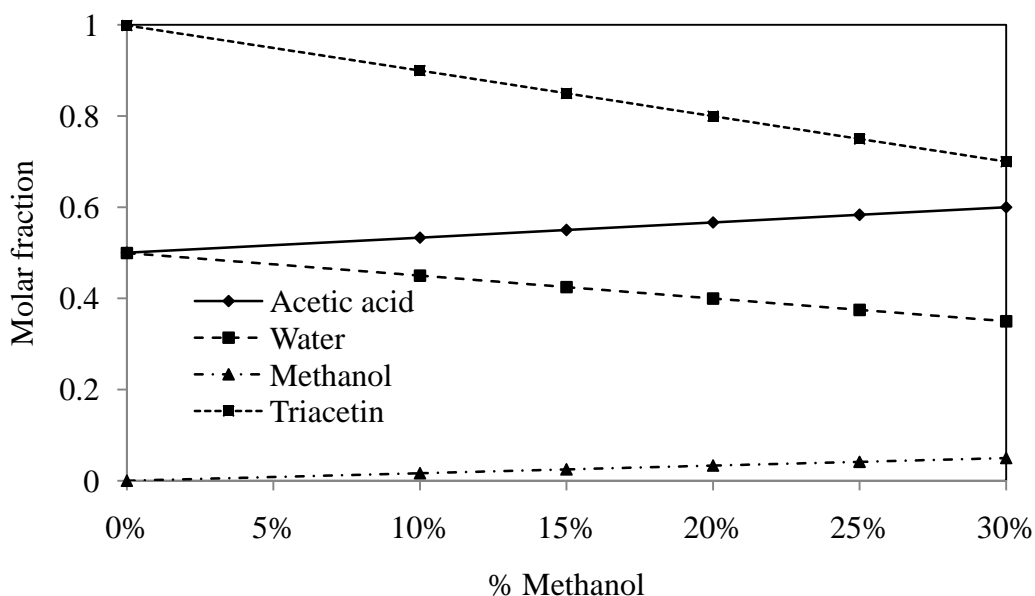

Fig. 6-3 Molar fraction of main component in the reactive distillation column when increasing the percentage of methanol in glycerol.

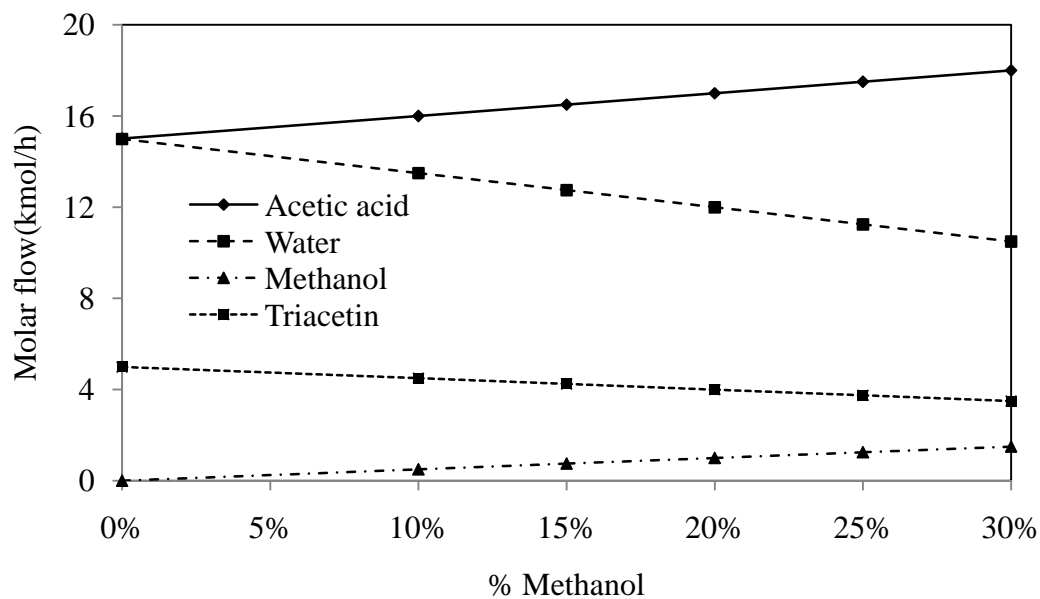

Fig. 6-4 Molar flow of main component in the reactive distillation column when increasing the percentage of methanol in glycerol.

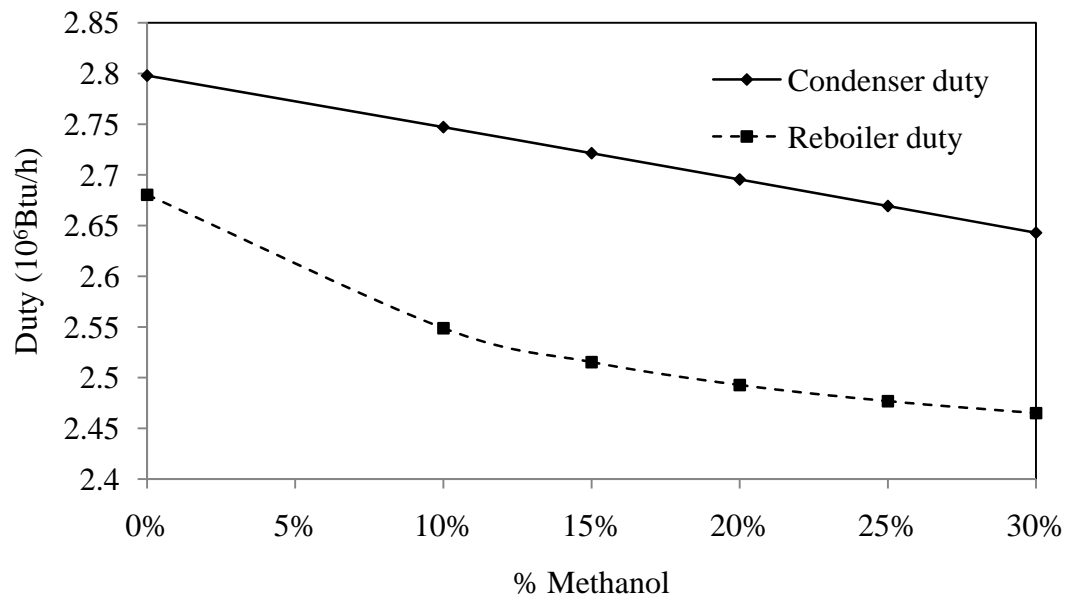

Fig. 6-5 Energy consumption in the reactive distillation columns when increasing the percentage of methanol in glycerol.

6.2 Configuration 2: Pretreatment of crude glycerol and triacetin production

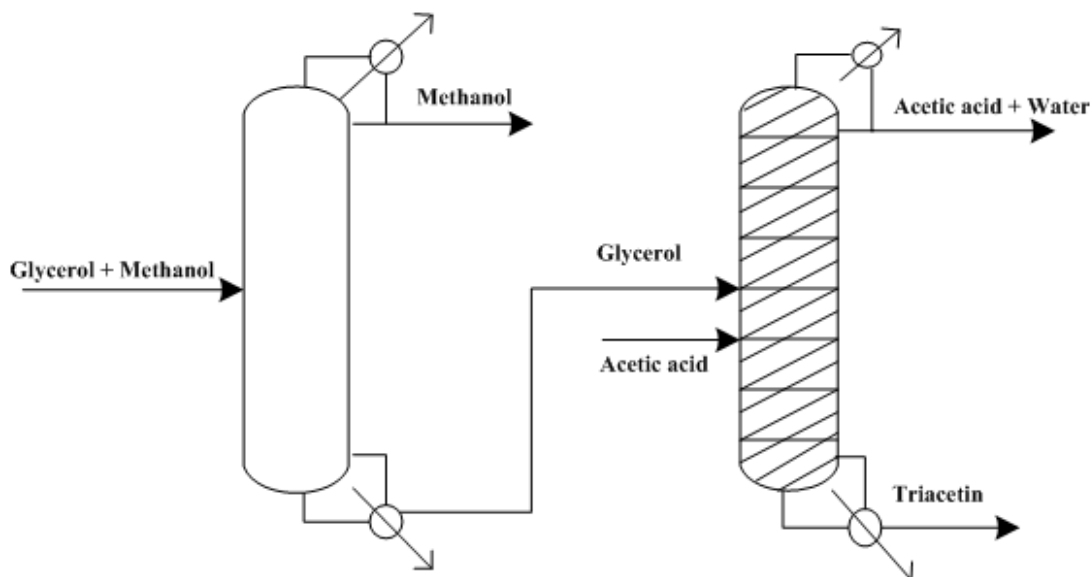

Fig. 6-6 The distillation column for removal methanol and the reactive distillation for triacetin production.

Table 6.2 Feed conditions and specification in distillation column for removal methanol and the reactive distillation for triacetin production.

Feed Conditions	Column specification				
	Distillation column		Reactive distillation column		
Temperature (K)	298	Total stages	10	Total stages	17
Pressure (bar)	1	Pressure (bar)	1	Pressure (bar)	1
Flow rate (kmol/h)		Reflux ratio	0.1	Reflux ratio	2.3
1) acetic acid	30	Bottom rate (kmol/h)	5	Bottom rate	5
2) glycerol	5	Feed location		(kmol/h)	
Mole fraction		1) glycerol +	2	Feed location	
1) glycerol +	1	methanol		1) glycerol	2
methanol				2) acetic acid	3

In this section at different ratios of glycerol per methanol was used to investigate its effect on the triacetin process by using removal of methanol at the first

of distillation column and connected to reactive distillation by adding acetic acid to produce a triacetin. Feed conditions in this studied are glycerol of 5 kmol/h, acetic acid of 30 kmol/h and pressure of 1 atm. In the distillation column has reflux ratio of 2, bottom rate 5 kmol/h and feed location of the glycerol mixed with methanol is 2. For the reactive distillation has reflux ratio of 2.3, bottom rate 5 kmol/h and feed location of the glycerol and acetic acid are 2 and 3, respectively. The details of feed conditions and specification are shown in Table 6.2. In this studied used a molar excess of acetic acid in the region of six times over glycerol in the feed. In the first distillation column used for removal of methanol mixed with glycerol at the top of the column. Then glycerol was removed at the bottom of column with connected to reactive distillation by adding acetic acid to produce a triacetin. In the reactive distillation column is produced triacetin at the bottom and allows the water, acetic acid and methanol to collect at the top of the column.

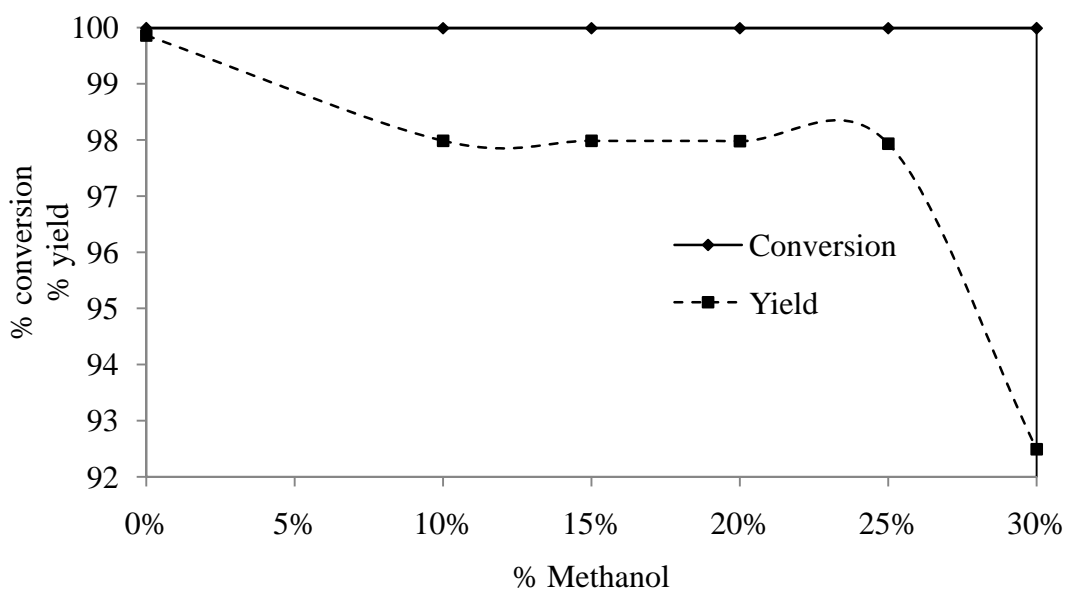

Fig. 6-7 Conversion of glycerol and yield of triacetin at different ratios of glycerol per methanol in the case of removal of methanol at the first of distillation column.

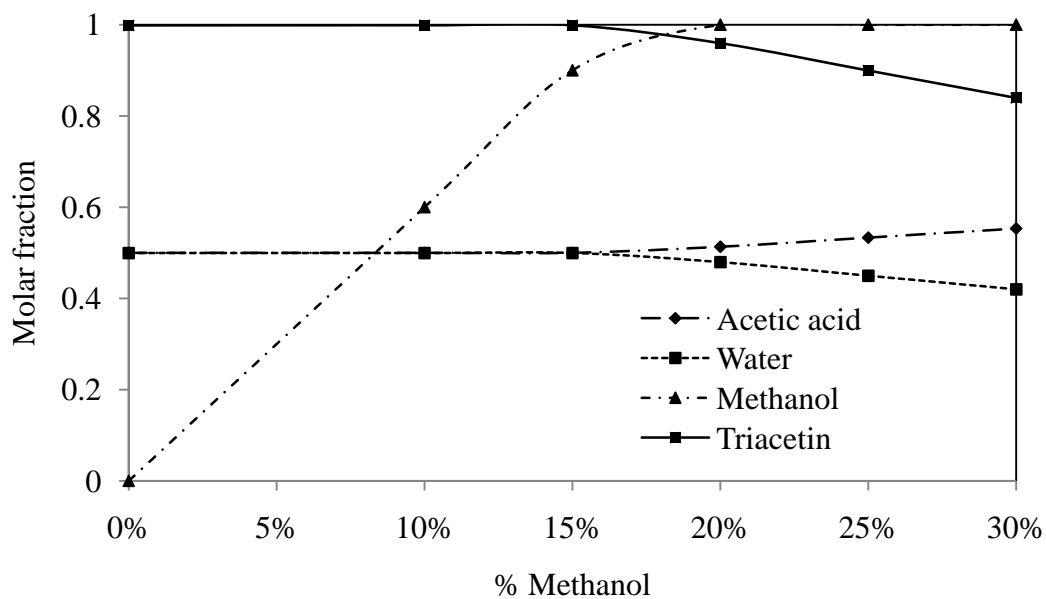

Fig. 6-8 Molar fraction of main component when increasing the percentage of methanol in glycerol in the case of removal of methanol at the first of distillation column.

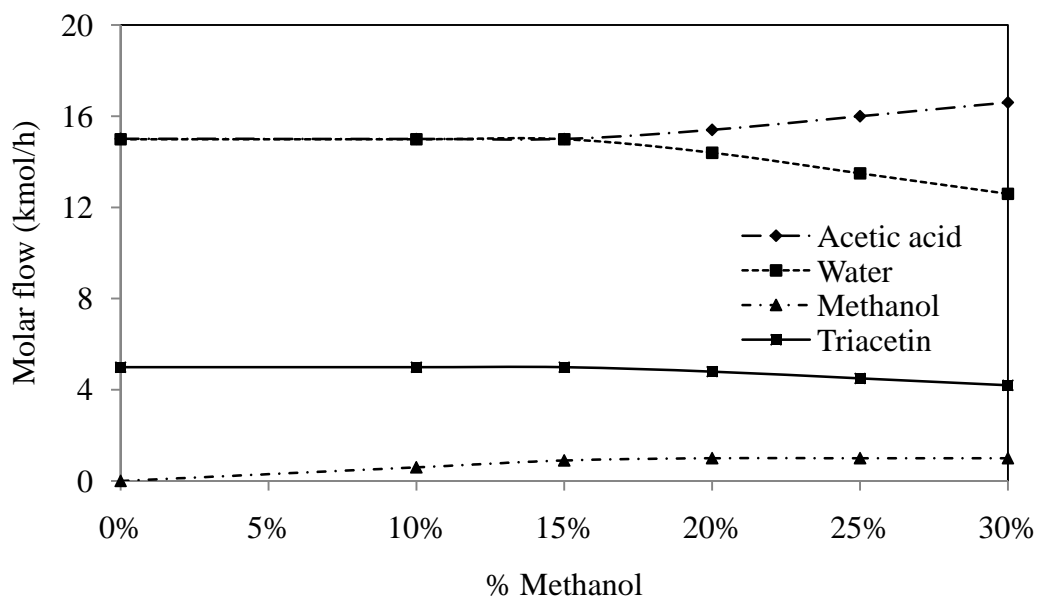

Fig. 6-9 Molar flow of main component when increasing the percentage of methanol in glycerol in the case of removal of methanol at the first of distillation column.

From Fig.6-7 shows the conversion of glycerol and yield of triacetin at different ratios of glycerol per methanol. It can be seen that when increasing the percentage of methanol in glycerol the conversion of glycerol decreased only slightly. Furthermore, the yield of triacetin reduced to 92.5% when methanol is mixed with the glycerol is 30%.

Figure 6-8 shows the effect of increasing the percentage of methanol in glycerol on the molar fraction of main component such as acetic acid, water, methanol and triacetin. The molar fraction of triacetin at the bottom of column decreases with an increase in the percentage of methanol. In addition, the molar fraction of water at the distillate stream has reduced but the molar fraction of acetic acid increased with an increasing amount of methanol in glycerol. Notice that the amount of methanol from the first separated by distillation column will be obtained with high purity. The results indicated that the increase in the percentage of methanol in glycerol makes the product has a molar fraction decrease.

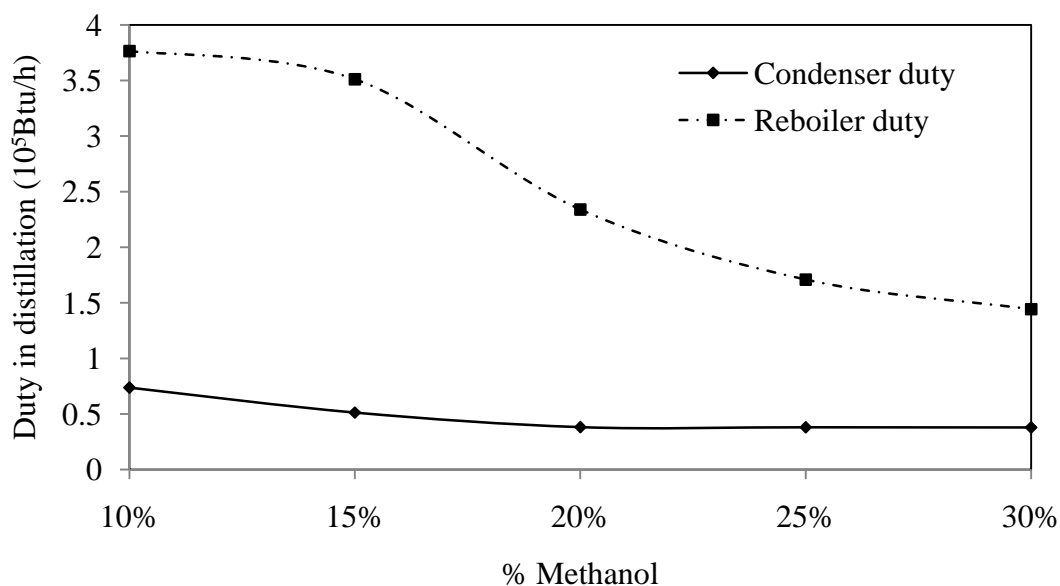

Fig. 6-10 Energy consumption in the distillation columns in the case of removal of methanol at the first of distillation column.

The mole flow rate of the main components in the reactive distillation is shown in Fig. 6-9. It can be seen that the rate of flow of the reactant (acetic acid and methanol) increased while the flow rate of product (water and triacetin) decreased.

The Figure 6-10 shows the results energy consumption in the distillation columns when increasing the percentage of methanol in glycerol. Considering the total energy consumptions in both condenser and reboiler of each column, it is found that the condenser duty and reboiler duty decrease when increase the percentage of methanol in glycerol. However, the Figure 6-11 shows the results energy consumption in the reactive distillation columns when increasing the percentage of methanol in glycerol. Considering the total energy consumptions in both condenser and reboiler of each column, it is found that the condenser duty and reboiler duty decrease when increase the percentage of methanol in glycerol.

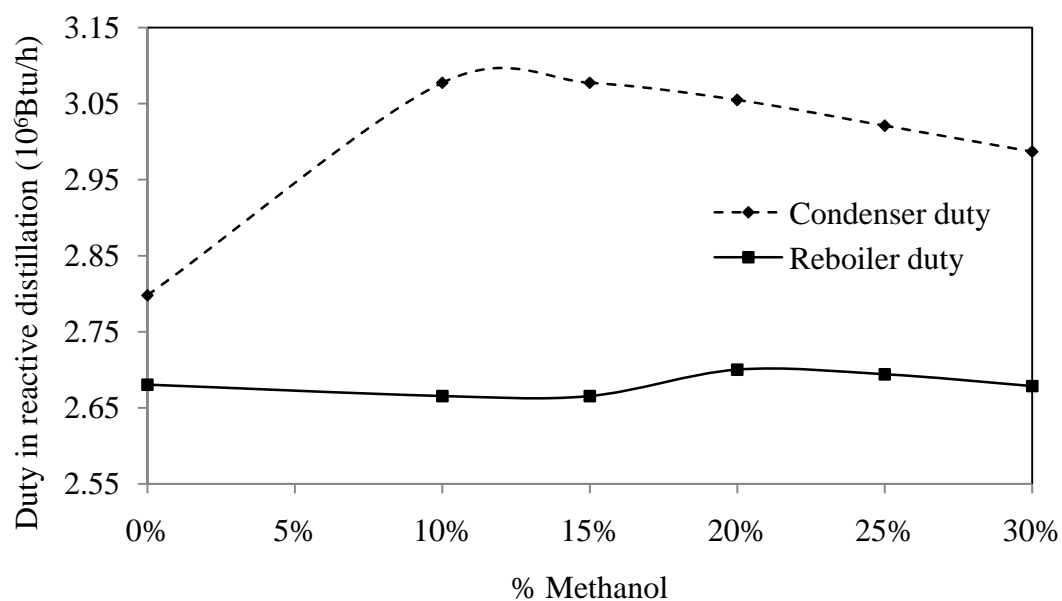

Fig. 6-11 Energy consumption in the reactive distillation columns in the case of removal of methanol at the first of distillation column.

6.3 Configuration 3: Using Crude glycerol for methyl acetate and triacetin production

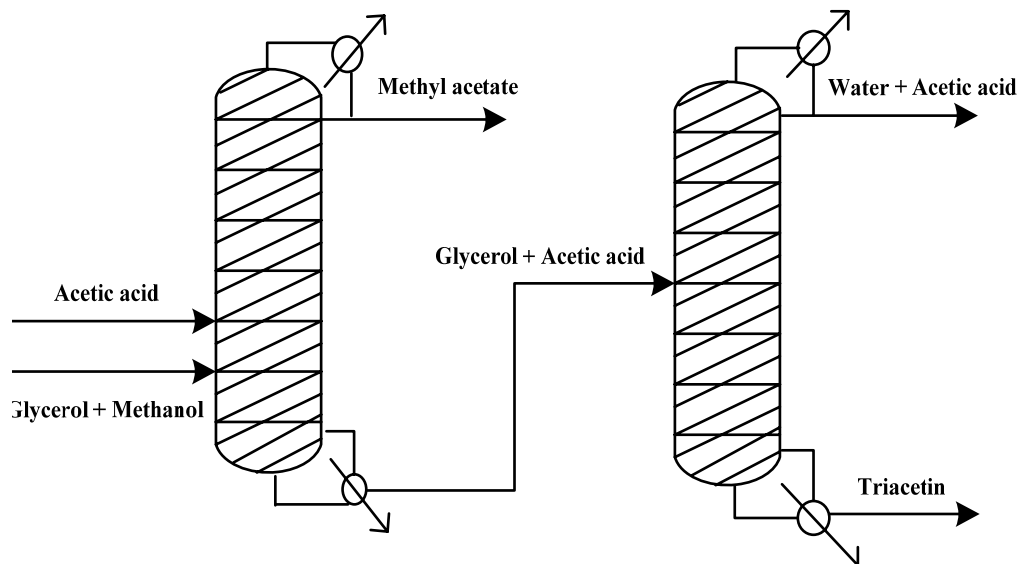

Fig. 6-12 The reactive distillation column for methyl acetate production follows by the reactive distillation column for triacetin production.

The third design is a device with two feeds, where acetic acid is fed near the top of the column and glycerol mixed with methanol near the bottom in equimolar amounts (Huss et.al, 2003). The column simultaneously produces methyl acetate as distillate, and glycerol and acetic acid as bottom product. In this design, the different ratio of glycerol per methanol was used to investigate its effect on the triacetin process by using reactive distillation. Feed conditions in this studied are glycerol mixed with methanol of 280 kmol/h, acetic acid of 280 kmol/h pressure at 1 atm. In the reactive distillation for methyl acetate production has reflux ratio of 2.8, bottom rate 510 kmol/h and feed location of the glycerol mixed with methanol is 36. For the reactive distillation for triacetin production has reflux ratio of 2, bottom rate 250 kmol/h and feed location of the glycerol and acetic acid are 2 and 3, respectively. The details of feed conditions and specification are shown in Table 6.3.

From Fig.6-13 shows the conversion of glycerol and yield of triacetin at different ratios of glycerol per methanol. It can be seen that when increasing the percentage of methanol in glycerol the conversion of glycerol decreased only slightly.

Furthermore, the yield of triacetin reduced to 99.85% when methanol is mixed with the glycerol is 30%.

Table 6.3 Feed conditions and specification in the reactive distillation column for methyl acetate production and the reactive distillation for triacetin production.

Feed Conditions	Column specification				
	Reactive distillation column for methyl acetate production		Reactive distillation column for triacetin production		
Temperature (K)	323	Total stages	38	Total stages	17
Pressure (bar)	1	Pressure (bar)	1	Pressure (bar)	1
Flow rate (kmol/h)		Reflux ratio	2.8	Reflux ratio	2
1) acetic acid	280	Bottom rate (kmol/h)	510	Bottom rate (kmol/h)	250
2) glycerol + methanol	280	Feed location		Feed location	
		1) acetic acid	3	1) acetic acid	3
Mole fraction		2) glycerol + methanol	36	2) glycerol + acetic acid	2
1) acetic acid	1				
2) glycerol + methanol	1				

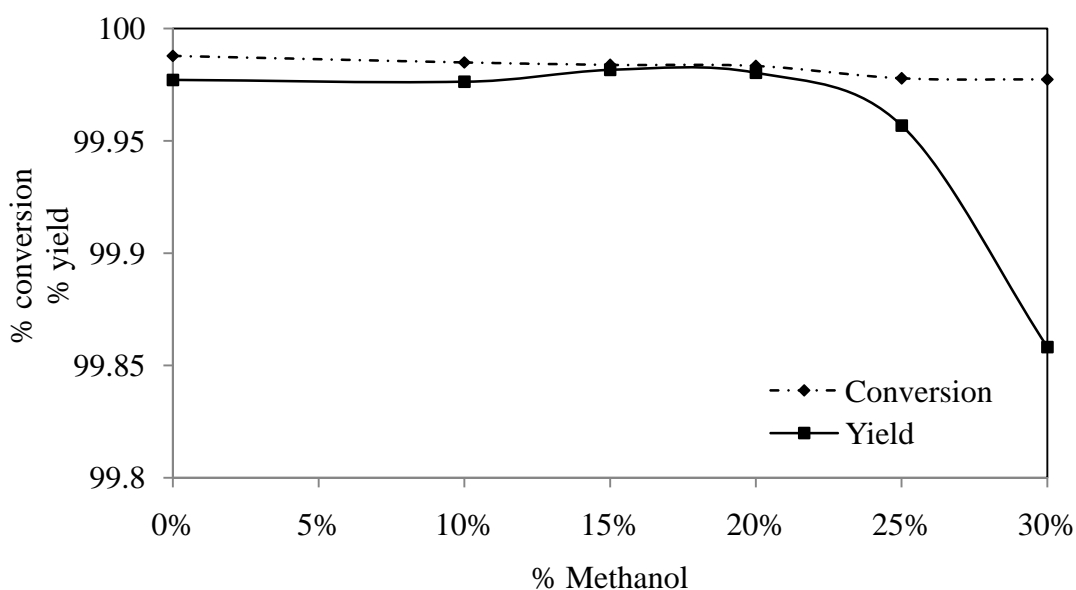

Fig. 6-13 Conversion of glycerol and yield of triacetin at different ratios of glycerol per methanol in the case of occurred methyl acetate.

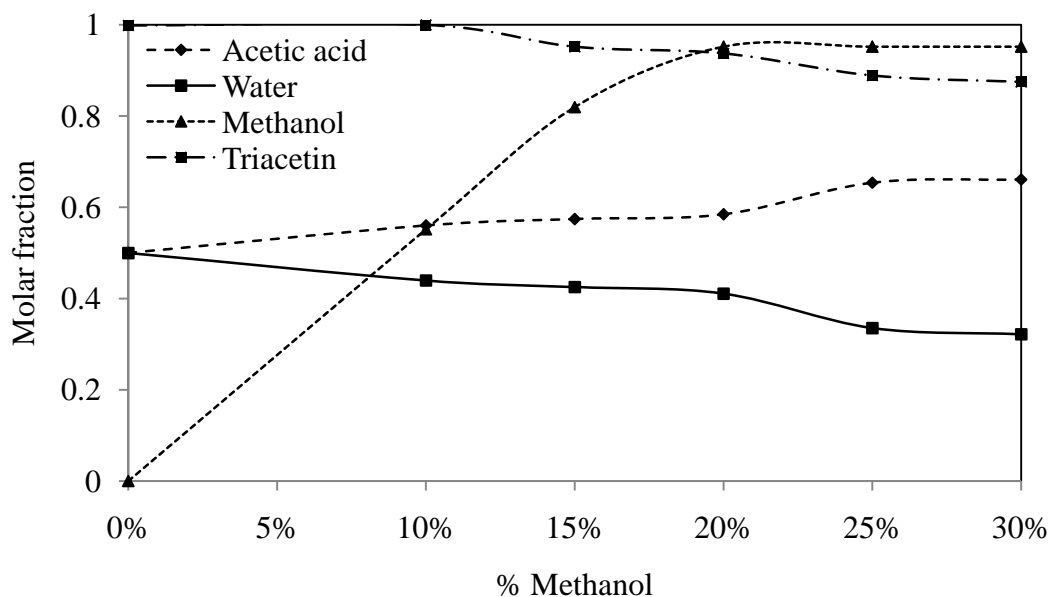

Fig. 6-14 Molar fraction of main component when increasing the percentage of methanol in glycerol in the case of occurred methyl acetate.

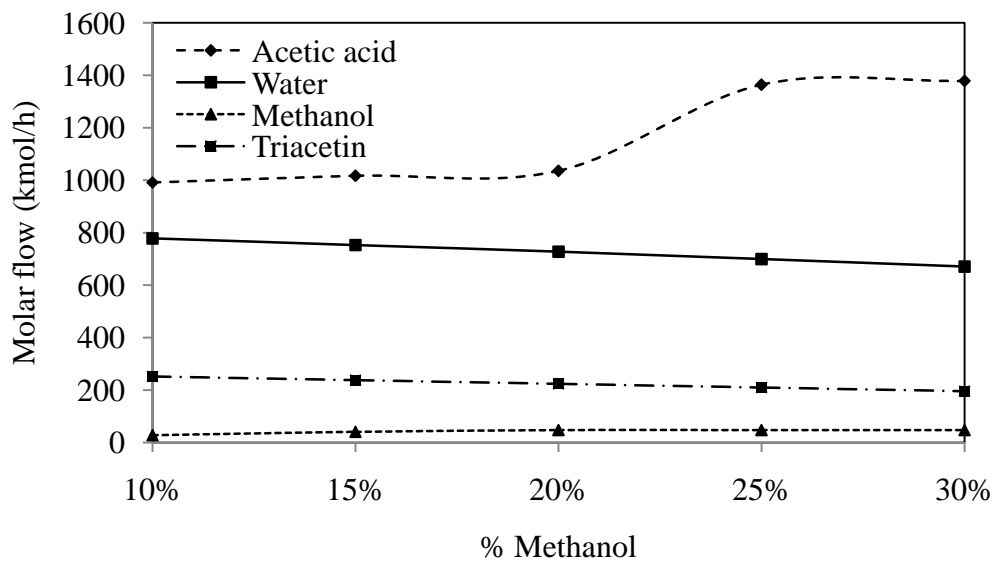

Fig. 6-15 Molar flow of main component when increasing the percentage of methanol in glycerol in the case of occurred methyl acetate.

Figure 6-14 shows the effect of increasing the percentage of methanol in glycerol on the molar fraction of main component such as acetic acid, water, methanol and triacetin. The molar fraction of triacetin at the bottom of column decreases with

an increase in the percentage of methanol. In addition, the molar fraction of water at the distillate stream has reduced but the molar fraction of acetic acid increased with an increasing amount of methanol in glycerol. The results indicate that the increase in the percentage of methanol in glycerol makes the product has a molar fraction decrease. It can be seen that the composition of the resulting mixture at the top of the column consists mainly of water and acetic acid while the bottom products comprise mostly the triacetin. The mole flow rate of the main components in the reactive distillation is shown in Fig. 6-15. It can be seen that the rate of flow of the reactant (acetic acid and methanol) increased while the flow rate of product (water and triacetin) decreased.

CHAPTER VII

CONCLUSIONS AND RECOMMENDATIONS

7.1 Conclusions

In this thesis, application of reactive distillation for production of triacetin from glycerol and acetic acid was studied.

The rate expressions of each reaction step can be summarized as follows:

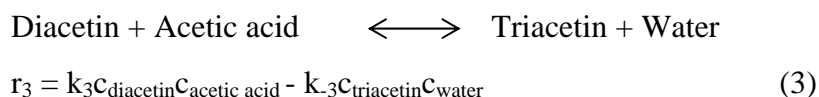
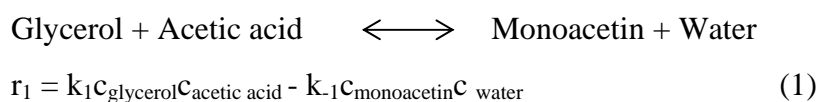

The works were divided into 3 sections; i.e. simulation of reactive distillation for triacetin production, energy integrated reactive distillation columns and using the crude glycerol instead of the pure glycerol for triacetin production. The results could be concluded as shown in the following sections.

7.1.1. Simulation of reactive distillation for triacetin production

Results under the standard condition indicated that triacetin was the main component of the bottom products 99.9% whereas the component of the distillate contained 50 mol% acetic acid and 49 mol% water. The conversion of glycerol and the yield of triacetin were 99.99% and 99.86%, respectively. The effects of various operating parameters on the reactive distillation performance were investigated by using the aspen plus simulator. From simulation studied, it is found that the optimal

configuration for the reactive distillation with molar ratio of 6:1, reflux ratio of 2 and distillate rate 30 kmol/h consists of 17 stages and feed stage of acetic acid and glycerol at stage 3 and 2, respectively.

Considering the energy requirement at minimum TAC, the overall reboiler heat duties is 2.12×10^6 Btu/h for the single column reactive distillation and the condenser heat duties is 2.24×10^6 Btu/h. The reflux ratio is 1.4 and the reactive distillation column is 2.48 ft diameter.

7.1.2. Energy integrated reactive distillation columns

In this studied, the design improvement will consider the use of process alternatives or complex column thermally coupled column configurations are modified and discussed. The design and operating variable values are selected based on sensitivity tests. The energy consumption in complex distillation arrangement will be compared to the reactive distillation with conventional distillation column (indirect sequence). Energy consumption in reactive indirect thermally coupled sequence can be saved by applying the column with side stripper arrangement around 48.6%. It can be concluded that heat integration potential of the process is reduced by applying complex distillation arrangement to this process.

7.1.3. Reactive distillation for triacetin production from crude glycerol

For this section, this work investigated the potential of using the crude glycerol to produce triacetin by reactive distillation column. By using the crude glycerol instead of the pure glycerol and studied at three various possible configurations. The first design is feed a mixture of glycerol and methanol into the reactive distillation for triacetin production. The second design is removal of methanol at the first of distillation column and connected to reactive distillation by adding acetic acid to produce a triacetin. The third design is the reactants consist of glycerol methanol and acetic acid feed to the reactive distillation column for methyl acetate production and then operated to the reactive distillation for triacetin production. The results obtained that an increase in the ratio of methanol to glycerol

in crude glycerol derived from biodiesel production can decrease the purity of triacetin at the bottom of reactive distillation. In addition, the mole fraction of water at the distillate stream was decreased. However, the conversion and yield obtained with the crude glycerol were nearly, or only slightly lower than those seen with the pure glycerol.

7.2 Recommendations

To improve the triacetin production it is recommended as follows:

From simulations of triacetin production in this work, it was recommended that other system configuration should also be investigated, for example, a reactive distillation with a pervaporation unit for recovering valuable chemicals present in the distillate back to the column. In addition, in the part of the studied of crude glycerol, more detailed analysis should be carried out. One problem with complex distillation thermally coupled arrangement is the controllability of the process. Therefore dynamic of process after applying the complex distillation arrangement to the process should be concerned.

REFERENCES

- Agrawal, R., and Fidkowski, Z.T. Improved Direct and Indirect Systems of Columns for Ternary Distillation. American Institute of Chemical Engineers 44 (1980): 823-830.
- Athalye, S.K., Garcia, R.A., and Wen, Z. Use of Biodiesel-Derived Crude Glycerol for Producing Eicosapentaenoic Acid (EPA) by the Fungus *Pythium irregular*. Journal of Agricultural and Food Chemistry 57 (2009): 2739-2744.
- Balaraju, M., Nikhitha, P., Jagadeeswaraiyah, K., Srilatha, K., Sai Prasad, P.S., and Lingaiah, N. Acetylation of glycerol to synthesize bioadditives over niobic acid supported tungstophosphoric acid catalysts. Fuel Processing Technology 91 (2010): 249-253.
- Barroso-Muñoz, F.O., Hernández S., and Ogunnaike B. Analysis of Design and Control of Reactive Thermally Coupled Distillation Sequences. Computer Aided Chemical Engineering 24 (2007): 877-882.
- Bohon, M.D., Metzger, B.A., Linak, W.P., King, C.J., and Roberts, W.L. Glycerol combustion and emissions. Proceedings of the Combustion Institute (2010).
- Bonet, J., Costa, J., Sire, R., Reneaume, J.M., Elena, A., Plesu, V., and Bozga, G. Revalorization of glycerol: Comestible oil from biodiesel Synthesis. Food and Bioproducts Processing 87 (2009): 171-178.
- Bonnardeaux, J. Glycerine overview. A report for the Department of Agriculture and Food. Government of Western Australia, November (2006).
- Caballero, J. A. Thermally Coupled Distillation. Computer Aided Chemical Engineering 27 (2009): 59-64.
- Casas, A., Ruiz, J.R., Ramos, M.J., and Perez, A. Effects of Triacetin on Biodiesel Quality. Energy Fuels 24 (2010): 4481-4489.
- Chi, Z., Pyle D., Wen, Z., Frear, C., and Chen, S. A laboratory study of producing docosahexaenoic acid from biodiesel-waste glycerol by microalgal fermentation. Process Biochemistry 42 (2007): 1537-1545.

- Chien, I.L, Teng, Y.P., Huang, H.P., and Tang, Y.T. Design and control of an ethyl acetate process: coupled reactor/column configuration. Journal of Process Control 15 (2005): 435-449.
- Dasari, M.A., Kiatsimkul, P.P., Sutterlin, W.R., and Suppes, G.J. Low-pressure hydrogenolysis of glycerol to propylene glycol. Applied Catalysis A: General 281 (2005): 225-231.
- Douglas, J.M.. Conceptual Design of Chemical Processes New York: McGraw-Hill (1988).
- Eastman Chemical Company, Publication February, U.S.A (1999). www.eastman.com/Literature_Center/L/L148.pdf.
- Engelien H.K., Larsson T., and Skogestad, S. Implementation of Optimal Operation for Heat Integrated Distillation Columns Chemical Engineering Research and Design. 81 (2003): 277-281.
- Finn, A. J. Consider Thermally Coupled Distillation Chemical Engineering Progress. 89 (1993): 41-45.
- Flores, O.A., Cardenas, J.C., Hernandez S., and Rico-Ramirez, V. Thermodynamic analysis of thermally coupled distillation sequences. Industrial & Engineering Chemistry Research 42 (2003): 5940–5945.
- Gelosa, D., Ramaioli, M., and Valente, G. Chromatographic Reactors: Esterification of Glycerol with Acetic Acid Using Acidic Polymeric Resins. Industrial and Engineering Chemistry Research 42 (2003): 6536-6544.
- Glinos K.N., and Malone, M.F. Design of Sidestream Distillation Columns. Industrial and Engineering Chemistry Process Design and Development 24 (1985): 822-828.
- Goncalves, V.L.C., Pinto, B.P., Silva, J.C., and Mota, C.J.A. Acetylation of glycerol catalyzed by different solid acids. Catalysis Today 133-135 (2008): 673-677.
- Hiremath, A., Kannabiran, M., and Rangaswamy, V. 1,3-Propanediol production from crude glycerol from jatropha biodiesel process. New Biotechnology 28 (2011): 19-23.
- Hernandez, S., and Jimenez, A. Design of Energy-Efficient Petlyuk Systems. Computers & Chemical Engineering 32 (1999): 1005-1010.

- Hernandez, S., Pereira-Pech, S., Jimenez, A., and Rico-Ramirez, V. Energy Efficiency of an Indirect Thermally Coupled Distillation Sequence. Canadian Journal of Chemical Engineering 81 (2008): 1087–1091.
- Hernandez, S., Segovia-Hernandez, J.G., and Rico-Ramirez V. Thermodynamically equivalent distillation schemes to the Petlyuk column for ternary mixtures. Energy 31 (2006): 2176–2183.
- Huss, R.S., Chen, F., Malone, M.F., and Doherty, M.F. Reactive distillation for methyl acetate production. Computers and Chemical Engineering 27 (2003): 1855-1866.
- Ito, T., Nakashimada, Y., Senba, K., Matsui, T., and Nishio, N. Hydrogen and Ethanol Production from Glycerol-Containing Wastes Discharged after Biodiesel Manufacturing Process. Journal of Bioscience and Bioengineering 100 (2005): 260-265.
- Kaibel, G., and Schoenmakers, H. Chemical Process Design in Practice. In: Grievink J, Schijndel JV, editors. Computer Aided Process Engineering 10 (2002): 9-14.
- Kerr, B.J., Weber, T.E., Dozier, W.A. and Kidd, M.T. Digestible and metabolizable energy content of crude glycerin originating from different sources in nursery pigs. American Society of Animal Science 87 (2009): 4042-4049.
- Kim, Y. H. Structural design and operation of a fully thermally coupled distillation column. Chemical Engineering Journal 85 (2002): 289–301.
- Lai, I.K., Hung, S.B., Hung, W.J., Yu, C.C., Lee, M.J., and Huang, H.P., Design and control of reactive distillation for ethyl and isopropyl acetates production with azeotropic feeds. Chemical Engineering Science 62 (2007): 878–898.
- Lammers, P.J., Kerr, B.J., Weber, T.E., Dozier, W.A., Kidd, M.T., Bregendahl, K., and Honeyman, M.S., Digestible and metabolizable energy of crude glycerol for growing pigs. American Society of Animal Science. 86 (2008): 602–608.
- Lee, M.Y., Jeong, S. Y., and Kim, Y.H. Application of a thermally coupled distillation column with separated main columns to gas concentration process. Korean Journal of Chemical Engineering 25 (2008): 1245-1251.

- Lopez, J.S., Santos, M.A.M., Perez, A.F.C., and Martin, A.M., Anaerobic digestion of glycerol derived from biodiesel manufacturing. Bioresource Technology 100 (2009): 5609–5615.
- Luo, Z.H., You, X.Z., and Zhong, J., Design of a Reactive Distillation Column for Direct Preparation of Dichloropropanol from Glycerol. Industrial & Engineering Chemistry Research 48 (2009): 10779–10787.
- Luyben, W.L., Tyreus B.D., and Luyben M.L., Plantwide Process Control McGraw-Hill, New York (1999).
- Malinen, I. and Tanskanen, J. Thermally Coupled Side-Column Configurations Enabling Distillation Boundary Crossing. 1. An Overview and a Solving Procedure. Industrial & Engineering Chemistry Research 48 (2009): 6387–6404.
- Mascia, M., Ferrara, F., Vacca, A., Tola, G., and Errico, M., Design of heat integrated distillation systems for a light ends separation plant. Applied Thermal Engineering 27 (2007): 1205-1211.
- Miranda-Galindo, E.Y., Segovia-Hernandez, J.G., Hernandez, S., Alvarez, G.R., Gutierrez-Antonio, C., and Briones-Ramirez, A. Design of Reactive Distillation with Thermal Coupling for the Synthesis of Biodiesel using Genetic Algorithms, 19th European Symposium on Computer Aided Process Engineering – ESCAPE19 (2009).
- Miranda-Galindo, E.Y., Segovia-Hernandez, J.G., Hernandez, S., Gutierrez-Antonio, C. and Briones-Ramirez, A. Reactive thermally coupled distillation sequences: Pareto front. Industrial & Engineering Chemistry Research 50 (2011): 926–938.
- Norman Tate & Co Ltd, 2003. Analytical and Consulting Chemists, Certificate of Analysis, Cert no. 3424.
- Onwudili, J. A., and Williams, P.T. Hydrothermal reforming of bio-diesel plant waste: Products distribution and characterization. Fuel 89 (2010): 501-509.
- Pagliari, M., and Rossi, M. The Future of Glycerol: New Uses of a Versatile Raw Material, The Royal Society of Chemistry, Cambridge CB4 0WF, UK (2008).

- Physical Properties of Glycerin and Its Solutions, Glycerin Producers Association, New York, 1975.
- Posada J.A., and Cardona, C.A. Design and analysis of fuel ethanol production from raw glycerol. Energy 35 (2010): 5286-5293.
- Puis, R.N.D., Lenth, C.W., and Gur, B.S. Glycerine derivatives, their properties and uses. Journal of the American Oil Chemists' Society 18 (1941): 31-37.
- Ramirez N. and Jimenez, A. Two Alternatives to Thermally Coupled Distillation Systems with Side Columns. American Institute of Chemical Engineers 50 (2004): 2971–2975.
- Re'v, E., Emtir, M., Szitkai, Z., Mizsey, P., and Fonyo, Z. Energy savings of integrated and coupled distillation systems. Computers and Chemical Engineering 25 (2001): 119–140.
- Reddy, P.S., Sudarsanam, P., Raju, G., and Reddy, B.M. Synthesis of bio-additives: Acetylation of glycerol over zirconia-based solid acid catalysts. Catalysis Communications 11 (2010): 1224–1228.
- Rivero, R., Garcia M., and Urquiza, J. Simulation, Exergy Analysis and Application of Diabatic Distillation to a Tertiary Amyl Methyl Ether Production Unit of a Crude Oil Refinery, Energy 29 (2004): 467–489.
- Sabourin-Provost, G., and Hallenbeck, P.C. High yield conversion of a crude glycerol fraction from biodiesel production to hydrogen by photofermentation. Bioresource Technology 100 (2009): 3513–3517.
- Schmitt, M., Hasse, H., Althaus, K., Schoenmakers, H., Gotze, L., and Moritz, P. Synthesis of n-hexyl acetate by reactive distillation. Chemical Engineering and Processing 43 (2004): 397–409.
- Schroder, A., and Sudekum, K-H., 1999. Glycerol as a by-product of biodiesel production in diets for ruminants. In Proceedings of the 10th International Rapeseed Conference. Canberra, Australia: The Regional Institute, Ltd. Available at: <http://www.regional.org.au/au/gcirc/1/241.htm#TopOfPage>.
- Selembo, P.A., Perez, J.M., Lloyd, W.A., and Logan, B.E. Enhanced Hydrogen and 1,3-Propanediol Production From Glycerol by Fermentation Using Mixed Cultures. Biotechnology and Bioengineering 104 (2009): 1098-1106.

- Smith R.M., Chemical Process: Design and Integration John Wiley & Sons Inc (2005).
- Song, W., Venimadhavan, G., Manning, J. M., Malone, M. F., and Doherty, M. F. Measurement of residue curve maps and heterogeneous kinetics in methyl acetate synthesis. Industrial Engineering and Chemical Research 37 (1998): 1917-1928.
- Suhendra, M.Sc. Integrated Improvement of Distillation Unit using Multicriteria Decision Making Analysis Dissertation. Brandenburgische Technische University (2006).
- Tedder, D.W. and Rudd, D.F. Parametric studies in industrial distillation. Part I. Design comparisons. American Institute of Chemical Engineers 24 (1978): 303–315.
- Thompson, J.C., and He, B. Characterization of crude glycerol from biodiesel production from multiple feedstocks. Applied Engineering in Agriculture 22 (2006): 261-265.
- Tuchlenski, A., Beckmann, A., Reusch, D., Dussel, R., Weidlich, U., and Janowsky, R. Reactive Distillation-industrial applications, process design & Scale-up. Chemical Engineering Science 56 (2001): 387-394.
- Valliyappan, T., Ferdous, D., Bakhshi, N.N., and Dalai A.K. Production of Hydrogen and Syngas via Steam Gasification of Glycerol in a Fixed-Bed Reactor. Topics in Catalysis 49 (2008): 59-67.
- Wang, S.J., Wong, D.S.H., and Yu, S.W. Design and control of transesterification reactive distillation with thermal coupling. Computers and Chemical Engineering 32 (2008): 3030–3037.
- Wolfson, A., Atyya, A., Dlugy, C., and Tavor, D. Glycerol triacetate as solvent and acyl donor in the production of isoamyl acetate with *Candida antarctica* lipase B. Bioprocess and biosystems engineering 33(2010): 363–366.
- Zeng, K.L., Kuo, C.L., and Chien, I.L. Design and control of butyl acrylate reactive distillation column system. Chemical engineering science 61 (2006): 4417-4431.

APPENDICES

APPENDIX A

MODIFIED KINETIC PARAMETERS OF METHYL ACETATE ESTERIFICATION

Methyl acetate (MeOAc) can be produced from the liquid phase reaction of acetic acid (HOAc) and methanol (MeOH) in the presence of an acid catalyst (e.g., sulfuric acid or a sulfonic acid ion exchange resin) at a pressure of 1 atm. The reaction is as follows:

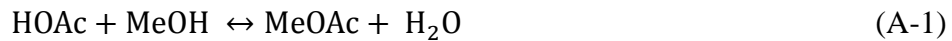

The kinetic rate constant of esterification reaction for methyl acetate production based on an activity model can be expressed as:

$$r = k_f \left(\alpha_{\text{HOAc}} \alpha_{\text{MeOH}} - \frac{\alpha_{\text{MeOAc}} \alpha_{\text{H}_2\text{O}}}{K_{\text{eq}}} \right) \quad (\text{A-2})$$

where the reaction equilibrium constant and the forward rate constant are given by:

$$K_{\text{eq}} = 2.32 \times \exp\left(\frac{782.98}{T}\right) \quad (\text{A-3})$$

$$k_f = 9.732 \times 10^8 \exp\left(-\frac{6287.7}{T}\right) \text{h}^{-1} \quad (\text{A-4})$$

where T is the reaction temperature (K). The reaction equilibrium constant was taken from Song et al. (1998) and the rate constant in Eq. (A-4) was obtained by fitting the pseudo-homogeneous rate equation (A-2) to the heterogeneous rate data in Song et al. (1998). The heat of reaction used in this work is -3.0165 kJ/mol, indicating a slightly exothermic reaction.

The kinetic parameter constants for the forward and reverse reactions at various temperatures are shown in Table A-1.

Table A-1 Kinetic rate constants based on activity at various temperatures.

T(K)	k_f (h^{-1})	k_r (h^{-1})
333	0.507	0.021
343	0.880	0.039
353	1.479	0.070
363	2.415	0.120
373	3.843	0.203

Next, the Arrhenius plot (Fig A-1) is used to determine the pre exponential factor and the activation energy for the reverse reaction.

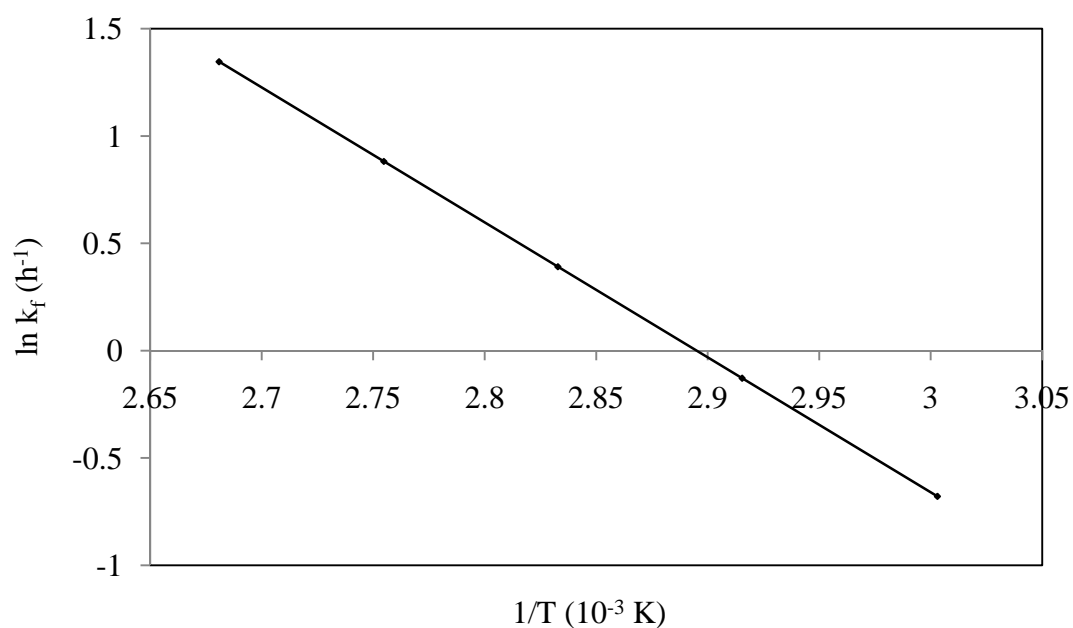
**Fig. A-1** Arrhenius plot for the reverse esterification reaction.

From the Arrhenius plot, the pre exponential factor and activation energy are obtained as follows:

$$\ln k_f = \ln A_f - \frac{E_f}{RT}$$

$$\ln k_f = 18.203 - \frac{6287.7}{T}$$

Therefore, $A_f = 8.044 \times 10^7$ and $E_f = 52275.94 \frac{J}{mol}$

APPENDIX B

SIZING OF EQUIPMENT AND CALCULATION OF COST

Correlations used for sizing of equipment and its parameters are shown in Table B-1 and B-2. A payback period of 3 years is assumed and a M&S index of 1431.7 (the year of 2008) is applied in the calculation. Materials of construction are stainless steel. The equipment is sized as follows:

Table B.1 Sizing of equipment

Parameter	Remarks	Equations
$A_{Reb} [m^2]$	Reboiler heat-transfer area	$A_{Reb} (ft^2) = \frac{Q_{Reb}}{U_{Reb} \cdot \Delta T_{Reb}}$
$A_{Cond} [m^2]$	Condenser heat-transfer area	$A_{Cond} (ft^2) = \frac{Q_{Cond}}{U_{Cond} \cdot \Delta T_{Cond}}$
$H [m]$	Column height	$H = (\text{tray spacing})(N_{tray})$

Table B.2 Notation and parameter values for sizing of equipment and cost calculation

Parameter	Value	Remarks
$C_{MS} [\$]$	1431.7	Marshall and Swift index (as of 2008)
$U_{Reb} [Btu / hft^2 F]$	150	overall heat-transfer coefficient of reboiler
$\Delta T_{Reb} [F]$	30	temperature driving force of reboiler
$U_{Cond} [Btu / hft^2 F]$	100	overall heat-transfer coefficient of condenser
$\Delta T_{Cond} [F]$	calculated	log-mean temperature driving force of condenser (temperature of process stream cooling water inlet and outlet temperature of 90 and 120 F, respectively)
$h_{weir} [m]$	0.1	weir height for tray

The evaluation of equipment cost follows the procedures of Douglas (1988)
Details are as follows:

Capital cost

Column cost

$$\text{Cost, \$} = \left(\frac{C_{MS}}{280} \right) 101.9 D^{1.066} H^{0.802} (2.18 + F_m F_p); \quad F_m = 3.67, F_p = 1.00$$

Tray cost

$$\text{Cost, \$} = \left(\frac{C_{MS}}{280} \right) 4.7 D^{1.55} H (F_s + F_t + F_m) \quad F_s = 1.00, F_t = 0.00,$$

$$F_m = 1.70$$

where D = diameter of the column (ft)

H = high of the column (ft)

Heat-exchanger cost

$$\text{Cost, \$} = \left(\frac{C_{MS}}{280} \right) 101.3 A^{0.65} (2.29 + (F_d + F_p) F_m); \quad F_d = 1.350 \text{ for reboiler,}$$

$$F_d = 1.000 \text{ for condenser, } F_p = 0.000, F_m = 3.750$$

where A = heat transfer area (ft²)

Operating cost

Steam cost

$$\text{Cost, \$/y} = \left(\frac{\$C_s}{1,000 \text{ lb}} \right) \left(\frac{Q_{Reb} \text{ lb}}{\Delta H_s \text{ h}} \right) \left(8150 \frac{\text{hr}}{\text{y}} \right)$$

where C_s = cost of steam (\$/1,000 lb steam)

Cooling cost

$$\text{Cost, } \$/\text{y} = \left(\frac{\$C_w}{1,000 \text{ gal}} \right) \left(\frac{1 \text{ gal}}{8.34 \text{ lb}} \right) \left(\frac{Q_{\text{Cond}} \text{ lb}}{30 \text{ h}} \right) \left(8150 \frac{\text{hr}}{\text{y}} \right)$$

where C_w = cost of cooling water (\$/1,000 gal cooling water)

Electricity cost

$$\text{Cost, } \$ = \left(\frac{0.04}{\text{kW} \cdot \text{h}} \right)$$

Example of calculations**1. Single reactive distillation for triacetin production from glycerol and acetic acid**

$$A_{\text{Reb}} = \frac{(2.12 \times 10^6 \text{ Btu} / \text{h})}{\left(150 \frac{\text{Btu}}{\text{h} \cdot \text{ft}^2 \text{F}} \right) (30 \text{ F})} = 472.01 \text{ ft}^2$$

$$A_{\text{Cond}} = \frac{(2.24 \times 10^6 \text{ Btu} / \text{h})}{\left(100 \frac{\text{Btu}}{\text{h} \cdot \text{ft}^2 \text{F}} \right) (115.35 \text{ F})} = 194.35 \text{ ft}^2$$

$$H = (\text{tray spacing})(N_{\text{tray}}) = (2 \text{ ft})(24) = 48 \text{ ft}$$

Capital cost

Column cost;

$$\text{Cost} = \left(\frac{1431.7}{280} \right) (101.9) (2.48^{1.066}) (48^{0.802}) (2.18 + 3.67) = \$179,004$$

Tray cost;

$$\text{Cost, \$} = \left(\frac{1431.7}{280} \right) (4.7) (2.48^{1.55}) (48) (1 + 0 + 1.7) = \$14,614$$

Heat-exchanger cost;

$$\text{Cost} = \left(\frac{1431.7}{280} \right) (101.3) (472^{0.65}) (2.29 + (1.35 + 0)(3.75)) = \$208,098$$

For reboiler

$$\text{Cost} = \left(\frac{1431.7}{280} \right) (101.3) (194.35^{0.65}) (2.29 + (1.000 + 0)(3.75)) = \$96,092$$

For condenser

Operating cost

Steam cost;

$$\text{Cost, \$/y} = \left(\frac{\$4}{1,000 \text{ lb}} \right) \left(\frac{2.12 \times 10^6 \frac{\text{Btu}}{\text{h}}}{489.14 \frac{\text{Btu}}{\text{lb}}} \right) \left(8150 \frac{\text{hr}}{\text{y}} \right) = \$/y 141,293$$

Cooling cost;

$$\text{Cost, \$/y} = \left(\frac{\$0.05}{1,000 \text{ gal}} \right) \left(\frac{1 \text{ gal}}{8.34 \text{ lb}} \right) \left(\frac{2.24 \times 10^6 \text{ lb}}{30 \text{ hr}} \right) \left(8150 \frac{\text{hr}}{\text{y}} \right) = \$/y 3,648$$

So

$$\begin{aligned} \text{TAC} &= \text{operating cost} + \frac{\text{capital cost}}{\text{pay-back period}} \\ &= 144,941 + \frac{497,810}{3} \\ &= \$/y 310,878 \end{aligned}$$

VITA

Pimpatthar Siricharnsakunchai was born on December 31, 1987, in Chonburi, Thailand. She received her Bachelor of Engineering Degree from the Department of Chemical Engineering, Srinakharinwirot University, Thailand, in 2009. Then, she continued her graduate study at the Department of Chemical Engineering, Faculty of Engineering, Chulalongkorn University, Thailand and received her Master of Engineering Degree in October 2011.