

การสกัดแยกและนำกลับแพลงก์ตอนและแพลงก์ตอนน้ำผ่านเยื่อแผ่นเหลวที่พองด้วยเส้นใยกลวง



นายเกริกกรัฐวิชัย วงศ์แก้ว

จุฬาลงกรณ์มหาวิทยาลัย

CHULALONGKORN UNIVERSITY

บทคัดย่อและแฟ้มข้อมูลฉบับเต็มของวิทยานิพนธ์ตั้งแต่ปีการศึกษา 2554 ที่ให้บริการในคลังปัญญาจุฬาฯ (CUIR)

เป็นแฟ้มข้อมูลของนิสิตเจ้าของวิทยานิพนธ์ ที่ส่งผ่านทางบัณฑิตวิทยาลัย

The abstract and full text of theses from the academic year 2011 in Chulalongkorn University Intellectual Repository (CUIR)

are the thesis authors' files submitted through the University Graduate School.

วิทยานิพนธ์นี้เป็นส่วนหนึ่งของการศึกษาตามหลักสูตรปริญญาวิทยาศาสตรดุษฎีบัณฑิต

สาขาวิชาวิศวกรรมเคมี ภาควิชาวิศวกรรมเคมี

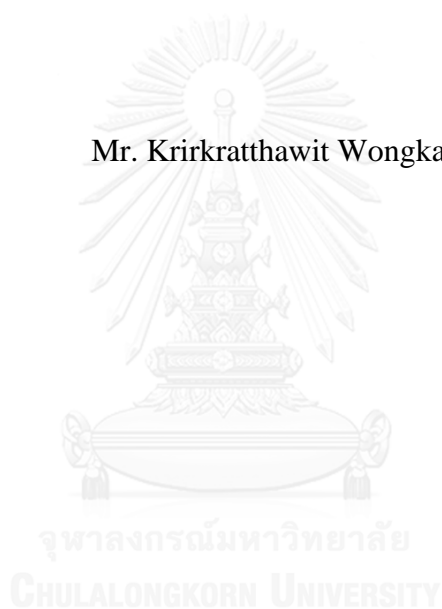
คณะวิศวกรรมศาสตร์ จุฬาลงกรณ์มหาวิทยาลัย

ปีการศึกษา 2559

ลิขสิทธิ์ของจุฬาลงกรณ์มหาวิทยาลัย

EXTRACTION AND RECOVERY OF PALLADIUM AND PLATINUM  
ACROSS HOLLOW FIBER SUPPORTED LIQUID MEMBRANE

Mr. Krirkratthawit Wongkaew



A Dissertation Submitted in Partial Fulfillment of the Requirements  
for the Degree of Doctor of Engineering Program in Chemical Engineering  
Department of Chemical Engineering  
Faculty of Engineering  
Chulalongkorn University  
Academic Year 2016  
Copyright of Chulalongkorn University

Thesis Title	EXTRACTION AND RECOVERY OF PALLADIUM AND PLATINUM ACROSS HOLLOW FIBER SUPPORTED LIQUID MEMBRANE
By	Mr. Krirkratthawit Wongkaew
Field of Study	Chemical Engineering
Thesis Advisor	Professor Ura Pancharoen, D.Eng.Sc.
Thesis Co-Advisor	Associate Professor Anchaleeporn Waritswat Lothongkum, D.Eng.

---

Accepted by the Faculty of Engineering, Chulalongkorn University in  
Partial Fulfillment of the Requirements for the Doctoral Degree

..... Dean of the Faculty of Engineering  
(Associate Professor Supot Teachavorasinskun, D.Eng.)

#### THESIS COMMITTEE

..... Chairman  
(Associate Professor Muenduen Phisalaphong, Ph.D.)

..... Thesis Advisor  
(Professor Ura Pancharoen, D.Eng.Sc.)

..... Thesis Co-Advisor  
(Associate Professor Anchaleeporn Waritswat Lothongkum, D.Eng.)

..... Examiner  
(Assistant Professor Amornchai Arpornwichanop, D.Eng.)

..... Examiner  
(Assistant Professor Suphot Phatanasri, D.Eng.)

..... External Examiner  
(Assistant Professor Prakorn Ramakul, D.Eng.)

เกริกรัฐวิษณุ วงศ์แก้ว : การสกัดแยกและนำกลับแพลเลเดียมและแพลทินัมผ่านเยื่อแผ่น  
 เหลวที่พองด้วยเส้นใยกลวง (EXTRACTION AND RECOVERY OF  
 PALLADIUM AND PLATINUM ACROSS HOLLOW FIBER  
 SUPPORTED LIQUID MEMBRANE) อ.ที่ปรึกษาวิทยานิพนธ์หลัก: ศ. ดร.อุรา  
 ปานเจริญ, อ.ที่ปรึกษาวิทยานิพนธ์ร่วม: รศ. ดร.อัญชลีพร วาริตสวัสดิ์ หล่อทองคำ,  
 หน้า.

งานวิจัยนี้ศึกษาการสกัดและการนำกลับแพลเลเดียมจากน้ำเสียของกระบวนการผลิต  
 แผงวงจรไฟฟ้าอิเล็กทรอนิกส์ชนิดยืดหยุ่น และแพลทินัมจากน้ำเสียของกระบวนการถลุงทองโดย  
 ระบบเยื่อแผ่นเหลวที่พองด้วยเส้นใยกลวง กระบวนการแยกแพลเลเดียม สารสกัดที่ใช้คือ LIX 84-I ที่  
 ความเข้มข้น 5% (v/v) ในตัวทำละลายเคโรซีน ค่าความเป็นกรด-เบสของสารละลายป้อนเท่ากับ 2  
 ส่วนสารละลายนำกลับที่ใช้คือสารละลายผสมของไทโอยูเรีย 0.8 M และกรดไฮโดรคลอริก 1.0  
 M และอัตราการไหลของสารละลายป้อนและสารละลายนำกลับเท่ากับ 100 มล./นาที่ ร้อยละของ  
 การสกัดและการนำกลับแพลเลเดียมที่ได้เท่ากับ 96 และ 91 ตามลำดับ สำหรับการแยกแพลทินัม  
 ได้ร้อยละของการสกัดและนำกลับแพลทินัมร้อยละ 96 และ 88 ตามลำดับ เมื่อใช้สารสกัด  
 Aliquat 336 ที่ความเข้มข้น 10 % (v/v) ในตัวทำละลายเคโรซีน ส่วนปัจจัยอื่นมีค่าเช่นเดียวกับการ  
 แยกแพลเลเดียมจากน้ำเสียกระบวนการผลิตแผงวงจรไฟฟ้าอิเล็กทรอนิกส์ชนิดยืดหยุ่น และ  
 พบว่าค่าปัจจัยการแยก (Separation Factor) แพลทินัมในน้ำเสียของกระบวนการถลุงทองออก  
 จากไอออนแพลเลเดียม ทองคำ ทองแดง และสังกะสี ประมาณ 17, 249, 970 และ 1276  
 ตามลำดับ นอกจากนี้ศึกษาการใช้ตัวทำละลายจากธรรมชาติ ได้แก่ น้ำมันดอกทานตะวัน น้ำมัน  
 มะพร้าว และน้ำมันถั่วเหลืองแทนตัวทำละลายเคโรซีนในระบบการแยกแพลทินัมจากน้ำเสียของ  
 กระบวนการถลุงทอง พบว่าน้ำมันดอกทานตะวันได้ร้อยละของการสกัดแพลทินัมสูงสุด แต่เมื่อ  
 เปรียบเทียบกับตัวทำละลายเคโรซีน ค่าการสกัดแพลทินัมที่ได้เพียง 65% งานวิจัยนี้ยังเปรียบเทียบผล  
 การทดลองการสกัดแพลเลเดียมกับการทำนายการถ่ายโอนมวลของแพลเลเดียมโดยสมการทาง  
 คณิตศาสตร์ที่พิจารณาเทอมของการแพร่ การเกิดปฏิกิริยาที่ผิวสัมผัสระหว่างวัฏภาคของสารละลาย  
 ป้อนและวัฏภาคของเยื่อแผ่นเหลว และการสะสมของไอออนโลหะในระบบของเยื่อแผ่นเหลว  
 พบว่าผลการคำนวณจากสมการทางคณิตศาสตร์มีความคลาดเคลื่อนกับผลการทดลองต่ำกว่า 5%

ภาควิชา วิศวกรรมเคมี

ลายมือชื่อนิสิต .....

สาขาวิชา วิศวกรรมเคมี

ลายมือชื่อ อ.ที่ปรึกษาหลัก .....

ปีการศึกษา 2559

ลายมือชื่อ อ.ที่ปรึกษาร่วม .....

# # 5271803921 : MAJOR CHEMICAL ENGINEERING

KEYWORDS: PALLADIUM, PLATINUM, HOLLOW FIBER SUPPORTED LIQUID MEMBRANE, EXTRACTION, STRIPPING, MASS TRANSFER

KRIRKRATTHAWIT WONGKAEW: EXTRACTION AND RECOVERY OF PALLADIUM AND PLATINUM ACROSS HOLLOW FIBER SUPPORTED LIQUID MEMBRANE. ADVISOR: PROF. URA PANCHAROEN, D.Eng.Sc., CO-ADVISOR: ASSOC. PROF. ANCHALEEPORN WARITSWAT LOTHONGKUM, D.Eng., pp.

The extraction and stripping of palladium from flexible printed circuit board (FPCB) wastewater, and platinum from gold refining (GR) wastewater via hollow fiber supported liquid membrane were studied. In case of the separation of palladium, the extraction and stripping reached 96% and 91%, respectively by using 5%(v/v) LIX84-I dissolved in kerosene. Other conditions were feed solution at pH 2, stripping solution consisting of 0.8 M thiourea and 1 M hydrochloric acid, and flow rates of feed and stripping solutions at 100 ml/min. For the extraction of platinum, 96% extraction and 88% stripping were obtained by using 10%(v/v) Aliquat 336 dissolved in kerosene while other operating conditions were similar to the separation of palladium from FPCB wastewater. The separation factor of platinum in GR wastewater from palladium, gold, copper and zinc ions were approximately 17, 249, 970 and 1276, respectively. Additionally, natural solvents, i.e., sunflower oil, coconut oil and soybean oil were used instead of kerosene in the separation of platinum from GR wastewater. It was found that sunflower oil gave the highest platinum extraction, however, only 65% was attained compared with kerosene. In addition, the estimated mass transfer results of the extraction of palladium by the mathematical model based on diffusion, the reaction at the interface of feed and liquid membrane phases, and the accumulation of the metal ions in liquid membrane phase were obtained. The deviation from the experimental results was lower than 5%.

Department: Chemical Engineering Student's Signature .....

Field of Study: Chemical Engineering Advisor's Signature .....

Academic Year: 2016 Co-Advisor's Signature .....

## ACKNOWLEDGEMENTS

I would like to express my grateful thanks to my advisor, Professor Dr. Ura Pancharoen, for his consistent kindness and support. He spent many years advising me. Without his encouragement, I might never have completed my doctoral dissertation. My deep appreciation also goes to my co-professor, Associate Professor Dr. Anchaleeporn Waritswat Lothongkum for her technical support, especially helping with proof reading. In addition, my appreciation goes to the thesis committee, Associate Professor Dr. Muenduen Phisalaphong, Assistant Professor Dr. Amornchai Arpornwichanop, Assistant Professor Dr. Suphot Phatanasri, and Assistant Professor Dr. Prakorn Ramakul.

I wish to acknowledge the Thailand Research Fund through the Royal Golden Jubilee Ph.D. Program (Grant No.PHD/0297/2550) for financial assistance. I would like to express my deep gratitude to Professor Dr. Milan Hronec for giving me many suggestions and taking care of me when I stayed in Slovakia. I am endlessly grateful to my family for their blessings, encouragement, inspiration and unconditional understanding at all times. I would not be here without their support. Many thanks also go to the Separation Laboratory, Department of Chemical Engineering, Chulalongkorn University, Bangkok, Thailand for supporting the apparatus. Many thanks are extended to Mr. Alan Wilcox, M.Ed (Victoria University of Manchester U.K.) for proof reading of the text.

## CONTENTS

	Page
THAI ABSTRACT .....	iv
ENGLISH ABSTRACT.....	v
ACKNOWLEDGEMENTS .....	vi
CONTENTS.....	vii
LIST OF TABLES .....	xiii
LIST OF FIGURES .....	xvi
CAPTER I.....	1
1.1 Description of dissertation .....	1
1.2 Palladium and platinum .....	6
1.2.1 Palladium .....	6
1.2.2 Platinum.....	7
1.3 Extractants.....	9
1.3.1 Acidic extractants .....	10
1.3.2 Chelating extractants .....	10
1.3.3 Neutral extractants .....	11
1.3.4 Ligand substitution extractants .....	12
1.3.5 Basic extractants (ion-pair extractants ).....	12
1.4 Feed solutions .....	16
1.5 Solvents.....	16
1.5.1 Organic solvents .....	17
1.5.2 Natural solvents .....	18
1.6 Stripping solutions .....	19
1.7 Operating temperature in feed and stripping solutions .....	20
1.8 pH of feed and stripping solutions .....	23
1.9 Concentration of the extractant.....	23
1.10 Concentration of the stripping solution.....	24
1.11 Flow rates of feed and stripping solutions .....	24
1.12 Transport across hollow fiber supported liquid membrane .....	25

	Page
1.13 Objectives of the dissertation.....	29
1.14 Scope of the dissertation .....	30
1.15 Expected results .....	32
1.16 Description of the dissertation .....	33
1.17 References.....	36
2.1 Abstract.....	45
2.2 Introduction.....	45
2.3 Theory.....	49
2.3.1 Transport mechanisms of Pd(II) across the liquid membrane phase.....	49
2.3.2 Thermodynamics .....	51
2.3.3 Diluents and liquid membrane stability.....	53
2.4 Experiment.....	55
2.4.1 Chemicals and reagents .....	55
2.4.2 Apparatus and analytical instruments.....	56
2.4.3 Procedures.....	58
2.5 Results and discussion .....	58
2.5.1 Influences of types of diluents.....	58
2.5.2 Influences of types of extractants and stripping agents .....	60
2.5.3 Influences of concentrations of extractant and stripping agent .....	63
2.5.4 Influences of pH and Pd(II) concentration in feed solution.....	67
2.5.5 Influences of hydrodynamics and operating time.....	69
2.5.6 Influences of operating temperature .....	71
2.5.7 Influences of separation cycles through the hollow fiber module.....	72
2.5.8 Influences of diluents on membrane stability.....	74
2.6 Conclusion .....	77
2.7 Acknowledgements.....	78
2.8 References.....	78
CHAPTER III .....	83
3.1 Abstract.....	84



	Page
3.2 Introduction.....	85
3.3 Theory .....	88
3.3.1 Extraction equilibrium ( $K_{ex}$ ).....	88
3.3.2 Distribution ratio (D) .....	91
3.3.3 Stoichiometric coefficient (n) .....	92
3.3.4 Determining the permeability coefficient (P) .....	92
3.3.5 Mass transfer modeling.....	93
3.3.6 Effect of temperature on extraction equilibrium .....	95
3.3.7 Hollow fiber model for extraction of stannous (IV) and palladium (II).....	96
3.4 Experimental .....	98
3.4.1 Feed solution and reagents.....	98
3.4.2 HFSLM apparatus.....	99
3.4.3 Procedures.....	100
3.5 Results and discussion .....	102
3.5.1 Effect of LIX 84-I concentration on the extractability of Sn(IV) and Pd(II)	102
3.5.2 Effect of stripping solution concentration .....	103
3.5.3 Effects of flow rate of feed and stripping solutions.....	104
3.5.4 Stoichiometric coefficient of Sn(IV) and Pd(II) extraction with LIX 84-I ..	105
3.5.5 Extraction equilibrium constant.....	107
3.5.6 The distribution ratios .....	110
3.5.7 Calculation of permeability .....	110
3.5.8 Mass transfer coefficients .....	113
3.5.9 Effect of temperature on extraction equilibrium.....	115
3.5.10 Verification of the model with the experimental results for Sn(IV) and Pd(II).....	118
3.6 Conclusion .....	120
3.7 Nomenclature .....	121
3.8 Acknowledgements.....	123
3.9 References.....	124

	Page
CHAPTER IV .....	128
4.1 Abstract .....	129
4.2 Introduction.....	130
4.3 Theory .....	134
4.3.1 Transport of platinum (IV) across the liquid membrane phase .....	134
4.3.2 Distribution ratio.....	136
4.3.3 Calculation of overall mass transfer resistance .....	137
4.3.4 Experimental design for RSM .....	140
4.4 Experiment.....	141
4.4.1 Chemicals and reagents .....	141
4.4.2 Apparatus .....	144
4.4.3 Procedures.....	145
4.5. Results and discussion .....	149
4.5.1 The influences of types and concentration of extractants.....	149
4.5.2 The influences of extractants on distribution ratio and permeability coefficient .....	152
4.5.3 The effect of extractants on mass transport resistance .....	155
4.5.4 Effects of flow rates of feed solution $Q_f$ and stripping solution $Q_s$ .....	156
4.5.5 Separation of platinum (IV) from industrial wastewater .....	157
4.5.6 Optimization of extraction of platinum (IV) .....	160
4.6. Conclusion .....	168
4.7 Acknowledgements.....	169
4.8 Nomenclature.....	169
4.9 References.....	170
CHAPTER V .....	176
5.1 Abstract .....	177
5.2 Introduction.....	177
5.3 Theory .....	180
5.3.1 Transportation of platinum (IV) across HFSLM .....	180

	Page
5.3.2 Distribution ratio, the extraction and stripping equilibrium constants .....	181
5.3.3 Permeability coefficient .....	183
5.3.4 Thermodynamic parameters and activation energy ( $E_a$ ) .....	183
5.3.5 Mass transfer resistance .....	185
5.3.6 The modified Apelblat equation .....	187
5.4 Experiment .....	188
5.4.1 Chemicals and reagents .....	188
5.4.2 Apparatus .....	192
5.4.3 Procedures .....	193
5.5 Results and discussion .....	195
5.5.1 The pH values of feed solution .....	195
5.5.2 Influences of toxic diluents on the extraction and stripping of platinum (IV) .....	198
5.5.3 Influences of non-toxic diluents on the extraction and stripping of platinum (IV) .....	203
5.5.4 Effect of temperature on non-toxic diluents for separation of platinum (IV) .....	207
5.5.5 The number of cycles .....	211
5.5.6 Mass transfer coefficients .....	214
5.5.7 Modeling .....	216
5.6 Conclusion .....	217
5.7 Acknowledgements .....	218
5.8 Nomenclature .....	218
5.9 References .....	221
CHAPTER VI .....	226
6.1 Conclusion .....	226
6.2 Limitation of the research .....	232
6.3 Recommendations for future studies .....	233

	Page
REFERENCES .....	233
APPENDIX A .....	236
A.1 Physical characteristics of the hollow fiber module .....	236
A.2 The efficiency of extraction and stripping of target ions .....	237
APPENDIX B .....	240
B.1 Oral presentations .....	240
B.2 Research in foreign laboratory .....	240
B.3. Scholarships .....	241
B.4 Peer reviewed journal publications published .....	241
VITA .....	243



## LIST OF TABLES

<b>Table 1. 1</b> Literature reviews on the separation of palladium ions using different methods.....	2
<b>Table 1. 2</b> Literature reviews on the separation of platinum ions using different methods.....	4
<b>Table 1. 3</b> Properties of palladium [53].....	6
<b>Table 1. 4</b> Properties of platinum [54] .....	8
<b>Table 1. 5</b> Compositions of gold refining wastewater. ....	16
<b>Table 1.6</b> Stripping agents from previous literature for this work .....	20
<b>Table 1. 7</b> Physical characteristics of the hollow fiber module .....	25
<b>Table 1. 8</b> Investigated operating conditions for the extraction and stripping of palladium(II) from flexible printed circuit board wastewater.....	31
<b>Table 1. 9</b> Investigated operating conditions for the extraction and stripping of platinum (IV) from gold refining wastewater .....	32
<b>Table 2. 1</b> Physical characteristics of the hollow fiber module. ....	57
<b>Table 2. 2</b> Performance of the diluents on the percentages of Pd(II) extraction and stripping. ....	59
<b>Table 3. 1</b> Literature reviews on the separation extraction of palladium and stannous.....	87
<b>Table 3. 2</b> Characteristics of the flexible printed circuit board industry wastewater.....	89

<b>Table 3. 3</b> Characteristics of the hollow fiber module. ....	100
<b>Table 3. 4</b> Distribution ratios for different concentrations of LIX 84-I. ....	110
<b>Table 3. 5</b> The permeability of stannous and palladium ions with different concentrations of LIX 84-I.....	112
<b>Table 3. 6</b> Thermodynamic data for Sn(IV) and Pd(II) in LIX 84-I 0.01 M.....	116
<b>Table 3. 7</b> Reaction order and reaction rate constants.....	119
<b>Table 4. 1</b> Summary of previous works on separation of platinum (IV) using different methods. ....	131
<b>Table 4. 2</b> Level and code of variables for Box-Behnken design. ....	141
<b>Table 4. 3</b> Extractants and stripping agents used in this study.....	143
<b>Table 4. 4</b> Compositions of gold refining wastewater. ....	144
<b>Table 4. 5</b> Properties of the hollow fiber module.....	145
<b>Table 4. 6</b> Optimized conditions for operation of HFSLM for separation of platinum (IV) .....	148
<b>Table 4. 7</b> Efficiency of HFSLM in terms of distribution ratios and permeability coefficients using different extractants under optimal conditions. ....	154
<b>Table 4. 8</b> Mass transfer resistances under optimum conditions.....	156
<b>Table 4. 9</b> The separation factor for validation at 10%(v/v) Aliquat 336.....	160
<b>Table 4. 10</b> Face-centred composite design matrix along with experimental and predicted values of platinum(IV) extraction across HFSLM.....	164

<b>Table 4. 11</b> ANOVA for the response surface quadratic polynomial model. ....	165
<b>Table 5. 1</b> The properties of feed solutions from gold refining processes .....	190
<b>Table 5. 2</b> The properties of toxic diluents.....	191
<b>Table 5. 3</b> The properties of non-toxic diluents .....	192
<b>Table 5. 4</b> Physical characteristics of the hollow fiber module .....	193
<b>Table 5. 5</b> The effect of toxic diluents on extraction equilibrium constants, stripping equilibrium constants, distribution ratios and permeability coefficient under optimized conditions.....	203
<b>Table 5. 6</b> The effect of non-toxic diluents on extraction equilibrium constants, stripping equilibrium constants, distribution ratios and permeability coefficients....	207
<b>Table 5. 7</b> The effect of temperature on efficiency of extraction of platinum (IV) using various non-toxic diluents .....	208
<b>Table 5. 8</b> The effect of non-toxic diluents and toxic diluents on the mass transfer resistances .....	215
<b>Table 5. 9</b> Estimated model parameters of a modified Apelblat model for non- toxic diluents.....	217
<b>Table A. 1</b> Physical characteristics of the hollow fiber module.....	236
<b>Table A. 2</b> The concentration of platinum(IV) in gold refining wastewater.....	239

## LIST OF FIGURES

<b>Fig.1. 1</b> Chemical structures of (a) LIX84-I (b) Aliquat 336 (c) Cyanex 923 (d) TBP and (e) TOPO.....	15
<b>Fig.1. 2</b> Schematic counter-current flow diagram for a single-module operation in the HFSLM system: 1) feed reservoir 2) gear pumps 3) inlet pressure gauges 4) outlet pressure gauges 5) hollow fiber module 6) flow meters 7) stripping reservoir 8) stirrer with temperature control and 9) temperature control box .....	26
<b>Fig.1. 3</b> The descriptive drawing of liquid membrane system [106] .....	28
<b>Fig.2. 1</b> Mass transport mechanism of Pd(II) across the liquid membrane phase using LIX 84-I as the extractant and the combination of $\text{NH}_2\text{CSNH}_2$ and HCl as the stripping solution.....	50
<b>Fig.2. 2</b> The chemical structures of LIX 84-I, TBP and TIBPS. ....	56
<b>Fig.2. 3</b> Percentages of extraction and stripping of Pd(II) against (a) types of extractants and (b) types of stripping agents under conditions: feed solution at pH 2, 2% (v/v) LIX 84-I, the combination of 1 M $\text{NH}_2\text{CSNH}_2$ and 1 M HCl, 100 mg/L Pd(II) in the feed solution and equal flow rates of feed and stripping solutions of 100 mL/min.....	62
<b>Fig.2. 4</b> Percentages of extraction of Pd(II) against concentrations of LIX 84-I and concentrations of $\text{NH}_2\text{CSNH}_2$ mixed with 1 M HCl under conditions: feed solution at pH 2, 100 mg/L Pd(II) in the feed solution, and equal flow rates of feed and stripping solutions at 100 mL/min. ....	65



- Fig.2. 5** Percentages of stripping of Pd(II) against concentrations of LIX 84–I and concentrations of  $\text{NH}_2\text{CSNH}_2$  mixed with 1 M HCl under conditions: feed solution at pH 2, 100 mg/L Pd(II) in the feed solution, and equal flow rates of feed and stripping solutions at 100 mL/min. ....66
- Fig.2. 6** Percentages of extraction and stripping of Pd(II) against (a) pH of feed solution and (b) initial concentration of Pd(II) in feed solution under conditions: 5% (v/v) LIX 84–I, the combination of 0.8 M  $\text{NH}_2\text{CSNH}_2$  and 1 M HCl and equal flow rates of feed and stripping solutions of 100 mL/min. ....68
- Fig.2. 7** Percentages of extraction and stripping of Pd(II) against (a) flow rates of feed and stripping solutions and (b) operating time under conditions: feed solution at pH 2, 100 mg/L Pd(II) in the feed solution, 5% (v/v) LIX 84–I, the combination of 0.8 M  $\text{NH}_2\text{CSNH}_2$  and 1 M HCl and equal flow rates of feed and stripping solutions at 100 mL/min. ....70
- Fig.2. 8** Percentages of extraction and stripping of Pd(II) against (a) number of separation cycles through a single-HFSLM module and (b) lifetime time of liquid membrane for any separation cycles through a single-HFSLM module under conditions: feed solution at pH 2, 100 mg/L Pd(II) in the feed solution, 5% (v/v) LIX 84–I, the combination of 0.8 M  $\text{NH}_2\text{CSNH}_2$  and 1 M HCl and equal flow rates of feed and stripping solutions at 100 mL/min. ....73
- Fig.2. 9** Lifetime of the liquid membrane studied by the HFSLM system against types of diluents with their polarity indexes under conditions: feed solution at pH 2, 100 mg/L Pd(II) in the feed solution, 5% (v/v) LIX 84–I, the combination of 0.8

M NH <sub>2</sub> CSNH <sub>2</sub> and 1 M HCl and equal flow rates of feed and stripping solutions at 100 mL/min.....	75
<b>Fig.2. 10</b> Percentages of extraction of Pd(II) studied by the HFSLM system against lifetime of individual diluents under conditions: feed solution at pH 2, 100 mg/L Pd(II) in the feed solution, 5% (v/v) LIX 84-I, the combination of 0.8 M NH <sub>2</sub> CSNH <sub>2</sub> and 1 M HCl and equal flow rates of feed and stripping solutions at 100 mL/min.....	77
<b>Fig.3. 1</b> Counter-transport scheme of SnCl <sub>4</sub> and (PdCl <sub>4</sub> ) <sup>2-</sup> extraction and stripping by LIX 84-I.....	90
<b>Fig.3. 2</b> The chemical structure of LIX 84-I.....	99
<b>Fig.3. 3</b> Schematic counter-current flow diagram for a single-module operation in the HFSLM: 1) feed reservoir, 2) gear pumps, 3) inlet pressure gauges, 4) outlet pressure gauges, 5) hollow fiber module, 6) flow meters, 7) stripping reservoir, 8) stirrer with temperature control, and 9) temperature control box.....	101
<b>Fig.3. 4</b> Percentage of extraction against LIX 84-I concentration: pH of feed solution = 3; strip solution using 6 M of hydrochloric acid; $Q_{feed} = Q_{strip} = 100$ ml/min; temperature 20 °C.....	102
<b>Fig.3. 5</b> The percentage of stripping against HCl concentrations: LIX 84-I 0.01 M, pH of feed = 3, $Q_{feed} = Q_{strip} = 100$ ml/min, temperature 20 °C.....	103
<b>Fig.3. 6</b> Extraction and stripping percentages of stannous and palladium ions against flow rate of feed and stripping solutions: (a) LIX 84-I 0.01 M; (b) LIX 84-	

I 0.06 M (pH of feed = 3; strip solution = 6 M of hydrochloric acid; system temperature = 20 °C).....	105
<b>Fig.3. 7</b> Plot of $\log(D_{Sn} \cdot [Cl^-]^2)$ versus $\log \frac{[(\overline{HR})_2]}{[H^+]}$ .....	106
<b>Fig.3. 8</b> Plot of $\log(D_{Pd} \cdot [Cl^-]^4)$ versus $\log \frac{[\overline{HR}]}{[H^+]}$ .....	107
<b>Fig.3. 9</b> Fitting of the equilibrium constant of stannous extraction with LIX 84-I. ..	108
<b>Fig.3. 10</b> Fitting of the equilibrium constant of palladium extraction with LIX 84-I .....	109
<b>Fig.3. 11</b> Plot of $-V_{feed} \ln (C_{feed}/C_{feed, 0})$ of stannous ions in the feed solution against time, with different LIX 84-I concentrations.....	111
<b>Fig.3. 12</b> Plot of $-V_{feed} \ln (C_{feed}/C_{feed, 0})$ of palladium ions in the feed solution against time, with different LIX 84-I concentrations.....	112
<b>Fig.3. 13</b> Plot of $1/P_{Sn}$ as a function of $[Cl^-]^2[H^+]^2 / [(\overline{HR})_2]^2$ .....	113
<b>Fig.3. 14</b> Plot of $1/P_{Pd}$ as a function of $[Cl^-]^4[H^+]^2 / [\overline{HR}]^2$ .....	114
<b>Fig.3. 15</b> Plots of $\ln(K_{ex, Sn})$ and $\ln(K_{ex, Pd})$ versus $1/T$ . .....	116
<b>Fig.3. 16</b> Plot of percentage of extraction versus system temperature. ( $Q_{feed} = Q_{strip} = 100$ mL/min.).....	117
<b>Fig.3. 17</b> Different concentrations of Pd(II) in the feed phase, plotted as a function of time.....	120

<b>Fig.4. 1</b> Transportation of platinum (IV) across hollow fiber supported liquid membrane.....	136
<b>Fig.4. 2</b> Chemical structures of (a) LIX84-I (b) Aliquat 336 (c) Cyanex 923 (d) TBP and (e) TOPO.....	142
<b>Fig.4. 3</b> Schematic representation of the flow diagram of feed and stripping solutions in counter-current direction via HFSLM: (1) feed reservoir (2) stripping solution reservoir (3) pump (4) flow regulator valve (5) flow indicator (6) pressure indicator and (7) HFSLM.....	147
<b>Fig.4. 4</b> The influence of types of extractants and their concentration on percentages of extraction platinum (IV) under pH 2 of feed solution, 0.8 M $\text{NH}_2\text{CSNH}_2$ in 1 M HCl, 100 mL/min equal flow rates of feed and stripping. ....	151
<b>Fig.4. 5</b> FT-IR spectrum of complex species in the liquid membrane phase (Pt(IV)-Aliquat 336-kerosene).....	151
<b>Fig.4. 6</b> Permeability coefficient versus operating time under concentration of extractants ranging from 3-15 % (v/v), pH 2 of feed solution, 0.8 M $\text{NH}_2\text{CSNH}_2$ in 1 M HCl, 100 mL/min equal flow rates of feed and stripping.....	153
<b>Fig.4. 7</b> Percentages of extraction of platinum (IV) versus the flow rate of feed and stripping solution between 100 and 500 mL/min under pH 2 of feed solution, 0.8 M $\text{NH}_2\text{CSNH}_2$ in 1 M HCl and 100 mL/min equal flow rates of feed and stripping. ....	157
<b>Fig.4. 8</b> The extraction and stripping of platinum(IV) and their impurity from gold refining wastewater under: pH 2 of feed solution, 10%(v/v) Aliquat 336, 0.8 M	

NH <sub>2</sub> CSNH <sub>2</sub> and 1 M HCl and equal flow rates of feed and stripping solution at 100 mL/ min.....	159
<b>Fig.4. 9</b> (a) The normal probability plot for platinum extraction; (b) plot of observed values versus predicted values and (c) plot of residuals versus observed values. ....	166
<b>Fig.4. 10</b> (a1 and a2) is corresponding three-dimensional surface plot and contour plot of concentration of Aliquat 336 %(v/v) and platinum (IV) mg/L, (b1 and b2) is of thiourea M and platinum (IV) mg/L and (c1 and c2) is of Aliquat 336 %(v/v) and thiourea .....	167
<b>Fig.5. 1</b> The structures of Aliquat 336.....	189
<b>Fig.5. 2</b> Flow diagram in the HFSLM system: (1) stirrer and heater (2) pH meter (3) feed reservoir (4) pressure indicator (5) flow regulator valve (6) flow indicator (7) pressure indicator (8) stripping reservoir, (9) HFSLM and (10) thermostatically controlled bath.....	194
<b>Fig.5. 3</b> The influence of pH of feed solution on the extraction of platinum(IV) from wastewater under 10%(v/v) Aliquat 336, 0.8 M NH <sub>2</sub> CSNH <sub>2</sub> in 1 M HCl, equal flow rates of feed and stripping at 100 mL/min and operating at ambient temperature .....	198
<b>Fig.5. 4</b> The effects of types of toxic diluents on (a) the extraction (b) the stripping for platinum (IV) across liquid membrane under optimized conditions under optimized conditions.....	202

<b>Fig.5. 5</b> The effects of types of non-toxic diluents (a) coconut oil (b) soybean oil and (c) sunflower oil on the extraction of platinum (IV) across liquid membrane under optimized conditions.....	206
<b>Fig.5. 6</b> The Van't Hoff equation plot between $\ln K_{ex}$ and $1/T$ under optimized conditions.....	210
<b>Fig.5. 7</b> The Arrhenius plot of platinum (IV) transport, plotting between $\ln J$ and $1/T$ under optimized conditions.....	211
<b>Fig.5. 8</b> Efficiency of extraction of platinum (IV) versus time at various number of separation cycles across HFSLM using (a) chloroform and (b) sunflower oil.....	214
<b>Fig.5. 9</b> Results from comparisons between a modified Apelblat equation versus various temperatures by adjusting of non-toxic diluents (a) coconut oil, (b) soybean oil and (c) sunflower oil.....	216
<b>Fig.A. 1</b> Email from supplier to confirm the number of hollow fibers in the contactor.....	236

## CAPTER I

### INTRODUCTION

#### 1.1 Description of dissertation

Palladium, a rare element, has special physical and chemical properties such as a high melting point, catalytic activities and corrosion resistance. Pure palladium has been extensively used in many applications: grids for electronic tubes, telephone circuits, electrical relays, corrosion resistance apparatus, resistance wires, and catalytic converters [1, 2]. However, palladium can affect the growth and health of living beings. For example, PdCl<sub>2</sub> at 5 ppm (mg/L) in drinking water has an adverse impact on human health [3]. Due to the continual increase for the industrial demand of palladium and environmental concerns, palladium has become the focus of investigation. Thus, reliable and effective methods for its separation and recovery from wastewater which contains palladium at relatively low concentration need to be developed. In the direct plating process (DPP) of the flexible printed circuit board industry, activating solution as well as precious metals (palladium and stannous) are found in the wastewater. The initial concentrations of stannous and palladium were 400 and 300 ppm, respectively. Conventional methods for separating palladium from aqueous solutions are precipitation [4], solvent extraction [5], ion exchange [6], bio-adsorption [7] and adsorption [8]. However, these methods have both advantages and disadvantages [9-13]. The previous works on separation of palladium ions using different methods are listed in **Table 1.1**.

**Table 1. 1** Literature reviews on the separation of palladium ions using different methods.

Authors	Metals	Ext.	Solvents	Method	%E	Refs.
Fontas et al.	Au(III), Pd(II) &Pt(IV)	thiacalix[4]	chloroform	LLE	100	[14]
Rovira et al.	Pd(II)	DEHTPA	kerosene	LLE	82.7	[15]
Zaghbani et al.	Pd(II) & Au(III)	thiacalix[4]	chloroform	SLM	76.4	[16]
Alexander et al.	Pd(II) & Pt(IV)	DSC	chloroform	LLE	100	[17]
Uheida et al.	Pd(II)	NTH	hexanol	HFSLM	N/A	[18]
Antic et al.	Pd (II)	PHE	kerosene	SSLM	90	[19]
Rastegarzadeh et al.	Pd (II)	Silica-PEG	-	Adsorption	99	[20]

**Note:** LLE (liquid liquid extraction); SLM (supported liquid membrane); DSC(N,N-dimethyldithiocarbamoylthoxy substituted calix [4] arene); NTH (nonylthiourea); HFSLM (hollow fiber supported liquid membrane); DEHTPA (di-(2-ethylhexyl) thiophosphoric acid); SSLM (solid supported liquid membranes) and PHE (N<sup>2</sup>-substituted N<sup>1</sup>-phenylbenzamidines); IE (ion exchange); %E ( %Extraction of Pt(IV)); Ext.(Extractants)



Platinum is 30 times rarer than gold since about only 0.003 ppb occurs in the Earth's crust. Platinum receives much attention as a precious metal. This is due to its wide use in various industries such as alloy material, whitening agent in jewelry and automobile catalyst [21]. Demands for platinum are increasing; however, its resource is limited. Therefore, the limited resources must be replenished by means of recycling platinum ions from secondary resources such as wastewater. Recycling of metal ions from wastewater is considered to be a major issue in conserving resources and reducing environmental pollutions. Wastewater from gold refining process is composed of platinum, palladium, gold, copper and zinc ions. Among these metal ions, the concentrations of palladium and platinum ions can be found at approximately 1 ppm and 5 ppm, respectively. In recent years, various techniques have been examined for the extraction and stripping of palladium and platinum from industrial wastes, e.g., wastewater, spent catalysts, electronic devices etc. [22]. However, effective and economic techniques to separate and recover platinum, especially platinum presenting in trace levels in gold refining process have always been lacking. Conventional techniques which are used to recover platinum from various solutions are precipitation [23], solvent extraction [24], adsorption [25] and ion exchange [26]. However, these systems have certain disadvantages [27, 28]. They are rather complex and the percentage recovery of metal ions is quite minimal [29, 30]. Previous works on the separation of platinum ions using different methods are listed in **Table 1.2**.

**Table 1. 2** Literature reviews on the separation of platinum ions using different methods.

Authors	Metals	Ext.	Solvents	Methods	%E	Refs.
Gupta et al.	Pt(IV),Pd(II) & Rh(III)	Cyanex 923	toluene	LLE	100	[9]
Michael et al.	Pt(IV)&Ru(III)	N/A	N/A	Adsorption	90.0	[28]
Kumar et al.	Pt(IV)	Cyanex 302	kerosene	LLE	85.4	[31]
Sun et al.	Pt(IV) & Pd(II)	Alamine 336	toluene	LLE	99.0	[32]
Sun et al.	Pt(IV)& Rh(III)	AGMP-1	N/A	IE	99.9	[33]
Lee et al.	Pt(IV)& Rh(III)	Alamine 308	kerosene	LLE	98.0	[34]
Sun et al.	Pt(IV)& Rh(III)	TOPO	toluene	LLE	99.0	[35]
Aleksandar et al.	Pt(IV),Pd(II) & Rh(III)	XUS 43600	N/A	Adsorption	99.9	[36]
Wei et al.	Au(III), Pt(IV) & Pd(II)	Aliquat- 336	benzene	LLE	99.8	[37]
Thi et al.	Pt(IV)& Pd(II)	Aliquat 336+TBP	kerosene	LLE	99.9	[38]

Note: LLE (liquid liquid extraction) and IE (ion exchange); %E ( %Extraction of Pt(IV)); Ext. (Ext.)

In order to overcome the disadvantages of conventional methods, hollow fiber supported liquid membrane (HFSLM) is recommended. It is worth noting that HFSLM can simultaneously extract target species of very low concentration and recover them in one single operation [39, 40]. The advantages of the HFSLM over the conventional methods were cited by Markoš et al.[41] such as lower energy consumption, lower operating costs, higher flux [11, 42] and easy scalability [43]. Thus, HFSLM has been applied to separate many types of metal ions, for example, toxic and precious metal ions from aqueous solutions. Fontàs et al. [11] studied the separation of rhodium ions from aqueous chloride solutions across HFSLM embedded by Aliquat 336 as an extractant. Results indicated that the HFSLM system can be effectively used for the recovery of rhodium ions from relatively low concentration solutions. In addition, Fontàs et al.[44] separated of palladium ions from spent automotive catalysts across HFSLM which was impregnated by Cyanex 471 as an extractant. Results indicated that HFSLM was successfully applied for the selective recovery and concentration of palladium from the aqueous feed solution. Chaturabul et al. [45] investigated the separation of palladium ions from waste aqua regia solutions across HFSLM embedded by a mixture of thioridazine and oleic acid as an extractant. Results indicated that HFSLM is efficient for the separation of palladium ions by employing a 3-cycle operation in repeated operating cycle mode. Manna et al. [46] applied the HFSLM embedded by TBP for the separation of medicinal catechins from tea leaves. Catechin and its derivatives from green tea leaves extract were successfully extracted. Kim et al.[47] applied the HFSLM system to CO<sub>2</sub> and N<sub>2</sub> gas separation. The experimental data indicated that CO<sub>2</sub> can be separated from the

mixture. Other applications of the HFSLM in various fields have been reported elsewhere [48-52].

## 1.2 Palladium and platinum

### 1.2.1 Palladium

#### 1.2.1.1 Physical and chemical properties

Palladium is one of precious metal ions referred to as the platinum group metals (PGM). It is a lustrous silver-white metal and has a face-centered cubic crystalline structure. At ambient temperature, palladium is strongly resistant to corrosion in air and to the action of acids. However, palladium is not resistant to corrosion in hot acids. Palladium can form many compounds and several complex salts. Properties of palladium are shown in **Table 1.3**.

**Table 1.3** Properties of palladium [53]

Properties	
Atomic number	46
Atomic mass (g/mol)	106.42
Electronegativity according to Pauling	2.2
Density (g/cm <sup>3</sup> at 20°C)	11.9
Melting point (°C)	1560
Boiling point (°C)	2927
Isotopes	9
Van der Waals radius (nm)	0.065
Ionic radius (nm)	0.137
Electronic shell	[ Kr ] 4d <sup>10</sup> 5s <sup>0</sup>

### 1.2.1.2 Applications of palladium

Palladium is used in various fields, for example, in catalytic processes, jewelry-making, catalytic converters, electrical appliances, electroplating, etc. Further, as a consequence of its corrosion resistance, a large application of palladium is in alloys used in low voltage electrical contacts.

### 1.2.1.3 Toxicity of palladium

Being poorly adsorbed by the body when ingested, palladium in some forms (i.e.  $\text{PdCl}_2$ ) is toxicity. It may cause skin sensitization and eyes or respiratory tract irritation.

## 1.2.2 Platinum

### 1.2.2.1 Physical and chemical properties

Platinum is one of precious metal ions referred to as the platinum group metals (PGM). Platinum is a lustrous silvery-white, malleable, ductile metal and a member of group 10 of the periodic table of the elements. Platinum is unaffected by air and water but can dissolve in hot aqua regia, hot concentrated phosphoric and sulfuric acids, and in molten alkali. It is as resistant as gold to corrosion and tarnishing. Indeed, platinum will not be oxidized in air no matter how strongly it is heated. The properties of platinum are shown in **Table 1.4**.

**Table 1. 4** Properties of platinum [54]

<b>Properties</b>	
Atomic number	78
Atomic mass (g/mol)	195.09
Electronegativity according to Pauling	2.2
Density (g/cm <sup>3</sup> at 20°C)	21.4
Melting point (°C)	1772
Boiling point (°C)	3800
Isotopes	13
Van der Waals radius (nm)	0.138
Ionic radius (nm)	0.096
Electronic shell	[ Xe ] 4f <sup>14</sup> 5d <sup>9</sup> 6s <sup>1</sup>

#### 1.2.2.2 Applications of platinum

Platinum has many applications. Because of its good characteristics, platinum is well-suited for making fine jewelry. Platinum and its alloys are employed in the production of surgical tools, laboratory utensils, electrical resistance wires, and electrical contact points. Up to 30% of platinum is used as a catalyst in a catalytic converter. In the field of the jewelry industry, 50% of platinum is utilized. Another 20% is used in the chemical, electrical, glass and aircraft industries.

#### 1.2.2.3 Toxicity of platinum

Platinum salts can cause several health effects, for example, DNA alterations, cancer, allergic reactions of the skin and mucous membrane. The application of

platinum in metal products is not known to cause many environmental problems but as can be seen, it can cause serious health conditions in the working place environment.

### 1.3 Extractants

The chemical structure of extractants for metal ion extraction is ligand-like, composing of a functional group with one donor atom such as nitrogen, phosphorus, oxygen, or sulfuric. Generally, functional groups are classified as acidic functional groups, e.g., carboxylic ( $-\text{CO}_2\text{H}$ ), sulfonic ( $-\text{SO}_3\text{H}$ ), phosphoric ( $-\text{PO}(\text{OH})_2$ ), and basic functional groups, e.g., ether ( $-\text{O}-$ ), alcohol ( $-\text{OH}$ ) and oxime ( $=\text{N}-\text{OH}$ ). Anyway, an increase of functional groups into the extractant molecule has been adopted to enhance the stability of chemical bonding of the metal extractant complexes. A chelating agent is a very well-known extractant used for metal ion extraction. It consists of three functional groups that are acid-acid, base-base and acid-base. According to the chemical structure of the extractant, transport mechanisms and metal ion forms, the extractants can be classified into [55-57]:

- a) Organic acid extractants - for the extraction of metal cations
- b) Chelating extractants - for the extraction of metal cations
- c) Neutral or solvating extractants - for the extraction of neutral metal complexes
- d) Ligand substitution extractants-for the extraction of metal anion complexes
- e) Basic or ion-pair extractants - for the extraction of metal anion complexes

### 1.3.1 Acidic extractants

An acid extractant is composed of a functional group of  $-\text{CO}_2\text{H}$ ,  $-\text{SO}_3\text{H}$  and  $-\text{PO}(\text{OH})_2$ . In an organic solvent, the acid extractant will deprotonate to a negative charged as  $\text{COO}^-$ ,  $\text{P}(\text{O})\text{O}^-$  and  $\text{SO}_3^-$ . Therefore, it can associate with the metal cation ( $M^{n+}$ ). Examples of organic acid extractants are di(2-ethylhexyl) phosphoric acid (D2EHPA) [58] and bis(2,2,4-trimethyl-pentyl) phosphinic acid (Cyanex 272) [31]. The general equation for the extraction of metal cation ( $M^{n+}$ ) by acid extractant ( $\overline{RH}$ ) is as follows:



### 1.3.2 Chelating extractants

Chelating extractants are often derived from analytical reagents such as LIX 84-I or 2'-hydroxy-5'-nonylacetophenone ketoxime ( $\text{C}_{17}\text{H}_{27}\text{NO}_2$ ) [59]. They react with cation species same as the acidic extractants. Chelating extractants chemically bond to cation species at two sites in a manner similar to holding an object between the ends of the thumb and the index finger [60]. When the chelating extractant bond to cation species, it releases hydrogen ion into the feed solution. Extractability of the chelating extractants increases with the pH of the feed solution. Decreasing of the pH promotes back-extraction or stripping. The extraction of metal ions with the chelating extractant ( $\overline{HL}$ ) such as the extraction of Pd(II) by using LIX 84-I is simplified as follows [61, 62]:





### 1.3.3 Neutral extractants

Neutral extractants contain a functional group of phosphate ester ( $\text{PO}(\text{OR})_3$ ), phosphine oxide ( $\text{R}_3\text{PO}$ ) or phosphine sulphide ( $\text{R}_3\text{PS}$ ). Tributyl phosphate (TBP) [35], dibutyl butylphosphonate (DBBP) and tri-isobutylphosphine sulfide (Cyanex 471) are good examples of neutral extractants. Neutral extractants are basic in nature and will coordinate to certain neutral metal ions in the feed solution by replacing water molecules around neutral metal ions, thereby altering the target metal to hydrophobic ions [56]. An example of the chemical reaction between the neutral metal complex ( $\text{MX}_2$ ) and DBBP ( $\text{C}_{12}\text{H}_{27}\text{PO}_3$ ) is expressed as follows

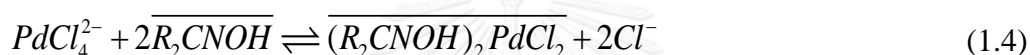


However, the extraction efficiency of neutral extractants is limited by the following factors:

- a) Stability of the chemical bonding of neutral metal complexes- the neutral metal complexes with low stability of chemical bonding dissociate to metal cations together with anions ( $\text{X}^-$ ) in the feed phase where the metal cations do not react with the neutral extractant.
- b) Solubility of metal - extractant complexes in the liquid membrane phase: the metal-extractant complexes with high solubility can diffuse rapidly through the liquid membrane phase.

### 1.3.4 Ligand substitution extractants

Some properties of ligand substitution extractants are similar to neutral extractants where they donate an electron to a metal ion. However, they differ from the neutral extractants by forming inner shell complexes with metals and displacing other ligands. In contrast, neutral extractants cannot displace other ligands. Mono-oxime ( $\overline{R_2CNOH}$ ) is an example of a ligand extractant. The extraction of Pd(II) from palladium chloride solution using mono-oxime is given by:



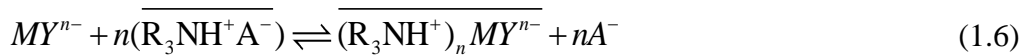
As shown in Eq. (1.4), two chloride ions of  $PdCl_4^{2-}$  are displaced by two molecules of mono-oxime to form a new complex species which is soluble in the organic extractant but not soluble in water [56].

### 1.3.5 Basic extractants (ion-pair extractants)

Basic extractants are tertiary amine and quaternary amine of general formula  $\overline{R_3N}$  and  $\overline{R_4N}$ , respectively. In order to extract the metal anions, tertiary amine must first react with acid (HA) to form an amine salt ( $\overline{R_3NH^+A^-}$ ) as shown below:



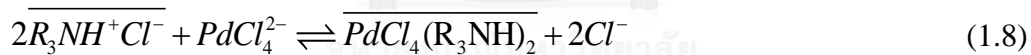
When tertiary amine associates with acid as an amine salt, it can extract metal anions  $MY^{n-}$  as shown below:



The example of a tertiary amine is trioctylamine (TOA). It is widely used to extract metal ions from various aqueous solutions. In the case of extraction of  $PdCl_4^{2-}$  by TOA, HCl is added to the aqueous feed solution in order to protonate  $\overline{R_3N}$  to the amine salt as shown in Eq (1.7) [63, 64]:



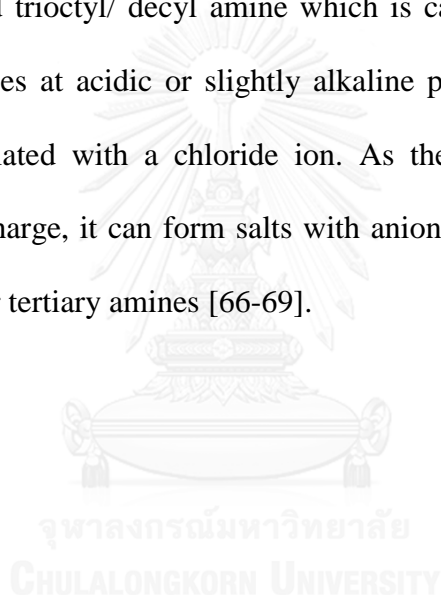
In the form of  $\overline{R_3NH^+Cl^-}$ , it can react with  $PdCl_4^{2-}$ . Then, the reaction of  $PdCl_4^{2-}$  and  $\overline{R_3NH^+Cl^-}$  is [63, 64]:

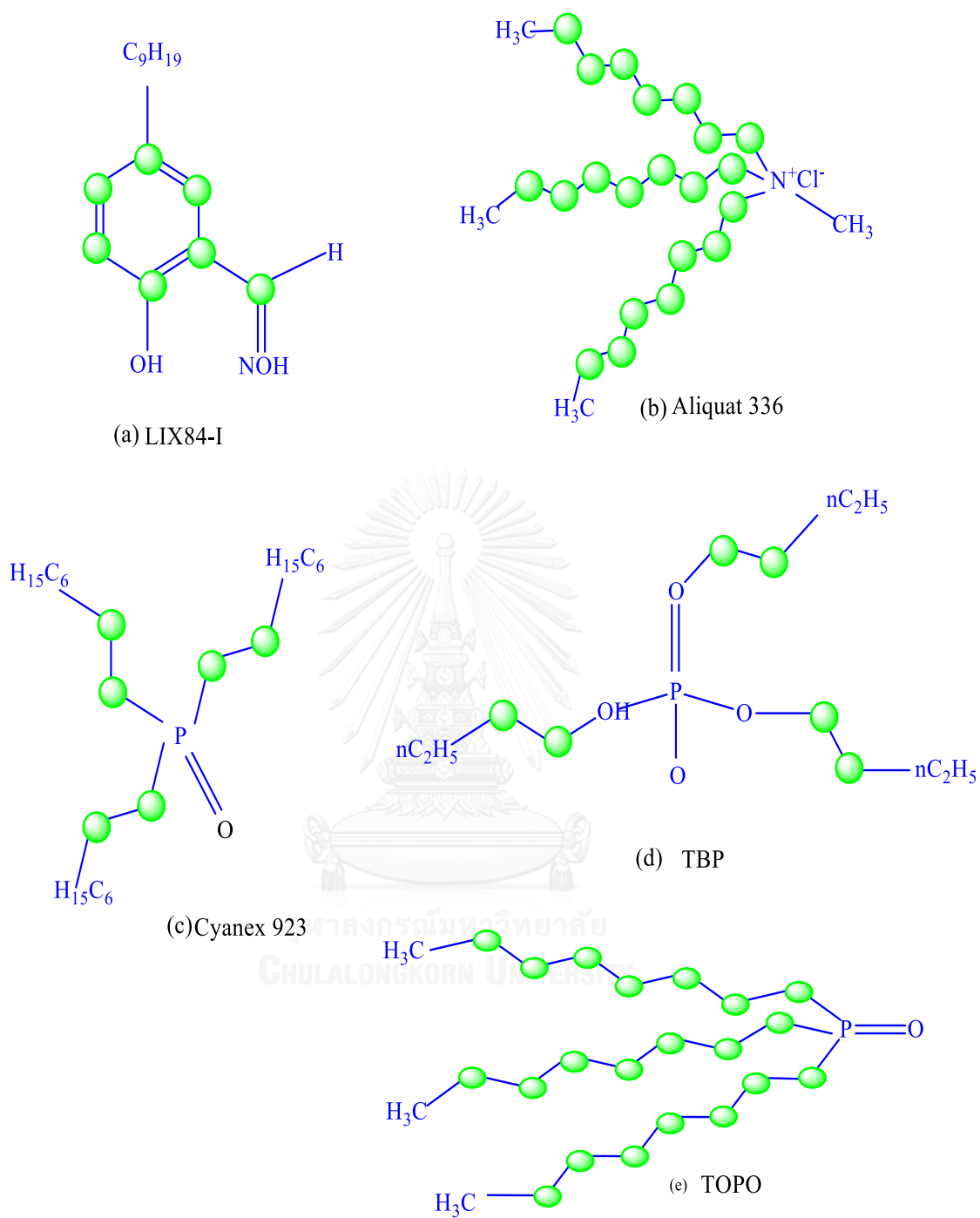


Due to the quaternary amine, trioctyl methyl ammonium chloride (Aliquat 336)  $\overline{(CH_3R_3N^+)Cl^-}$  can react with anions without adding any acid as shown [65]:



In this work, LIX84-I, Aliquat 336, Cyanex 923, tri-n-butyl phosphate (TBP) and trioctylphosphine oxide (TOPO) were dissolved in organic solvents and used as the liquid membrane. Their structures are shown in **Fig.1.1**. LIX 84-I was selected to separate palladium ions because it is a water insoluble 2-hydroxy-5-nonylacetophenone oxime. It forms water insoluble complexes with various metallic cations [61, 62]. In case of the separation of platinum ions, Aliquat 336 was selected because it is a water insoluble quaternary ammonium salt produced by the methylation of mixed trioctyl/ decyl amine which is capable of forming oil soluble salts of anionic species at acidic or slightly alkaline pH. It is composed of a large organic cation associated with a chloride ion. As the ammonium structure has a permanent positive charge, it can form salts with anions over a wider pH range than primary, secondary or tertiary amines [66-69].





**Fig.1. 1** Chemical structures of (a) LIX84-I (b) Aliquat 336 (c) Cyanex 923 (d) TBP and (e) TOPO

## 1.4 Feed solutions

In flexible printed circuit board (FPCB) industry, five main processes are computer numerical control process (CNC), direct plating process (DPP), plated through-hole process (PTH) [70], circuit-forming process (CIR) and the final process (FIN). Palladium and stannous found from the activating solution in DPP go to wastewater. The initial concentrations of palladium and stannous in the activating solution are 300 and 400 ppm, respectively

Due to the increasing industrial demand for platinum and limited resource, the secondary sources like wastewater, which contains platinum even at a relatively low concentration, is attractive. **Table 1.5** shows that the secondary source of wastewater from gold refining process contains platinum at a low concentration approximately 5 mg/L and other precious metal ions as well [71].

**Table 1. 5** Compositions of gold refining wastewater.

Metals	Pt(IV)	Pd(II)	Au(III)	Cu(II)	Zn(II)
Concentration (ppm)	5.00	0.88	0.94	0.55	0.12

## 1.5 Solvents

It is important to use a suitable solvent to dissolve and impregnate the extractant into pores of hollow fiber to make a three-phase HFSLM that ensure excellent extraction and stripping of the target ions. A suitable solvent has to satisfy the requirement of having high capacity in dissolving the extractant and allowing an

ion-pair formation between target ion and extractant. In addition, the solvent must not only having low viscosity in order to promote high target-ion fluxes through liquid membrane but also having low toxicity [72].

### 1.5.1 Organic solvents

Organic solvents are divided into 2 groups: polar and non-polar. The polarity of organic solvents is indicated by the dielectric constant (or relative permittivity) that represents the strength of the electric field surrounding the molecules of organic solvents[73]. The solvent having dielectric constant lower than 15 is classified as non-polar solvent [74]. For the extraction and recovery of metal ions, the organic solvent is a media that helps the diffusion of metal-extractant complexes and extractant. The metal-extractant complexes and the extractant form solvation molecules in the organic solvent by hydrogen bonding [75].

The stability of solvation molecules depends on the polarity of the organic solvents [76]. Thus, the metal - extractant complexes and extractant interact better with polar solvents than non-polar solvents [77]. However, the polar solvents also interact well with water, leading to the loss of liquid membrane phase to the feed and stripping phases [78]. Many literature reviews reported the effect of organic solvents on the extraction and stripping of target metal ions and stability of the liquid membrane across HFSLM [44, 79]. Fontàs et al.[44] investigated the effect of solvents (Cumene, 3-chlorotoluene, anethol, dicyclopentadiene, dodecane, kerosene and decaline) on the separation of Pd(II), Pt(IV) and Rh(III) using Cyanex 471 as the extractant. Of all the studied solvents, 3-chlorotoluene is the most favorable solvent because it shows the highest permeability. Leepipatpiboon et al. [79] investigated the

performances of seven solvents (i.e., hexane, decanol, chlorobenzene, benzene, dichloromethane, ethylene dichloride and chloroform) on the extraction of Co(II) and Ni(II) using Alamine 300 as the extractant. Hexane attained the highest Co(II) extraction of 82% for 200 min through its lifetime. Other significant properties of organic solvents are viscosity and volatility. The organic solvents having low viscosity help the diffusion of metal-extractant complexes and extractant through liquid membrane phase [80]. The organic solvents having high volatility can easily volatile from liquid membrane phase, and consequently the extraction efficiency decreases. The typical organic solvents used are aliphatic and aromatic hydrocarbons, hydrophobic ethers and esters, long chain alcohols and mixtures of technical solvents like kerosene.

### **1.5.2 Natural solvents**

Vegetable oils, for example, soybean oil, sunflower oil and coconut oil are greener substitute natural solvents that are considered to replace the organic solvents as their distinctive characteristics are nontoxicity, inflammability, nonvolatility, renewability and biodegradability [81]. Furthermore, natural solvents have unlimited resources. A key issue in the area of supported liquid membrane is high performance of the HFSLM, safer operation, and more environmentally friendly solvents. Previous research has highlighted the effect of vegetable oils on liquid membrane system for successful separation and recovery against mercury [82], methylene blue [83] and copper [84]. Chakrabarty et al, [82] investigated the separation of mercury ions from aqueous solution through SLM using environmentally benign solvents. Results indicated that the SLM using the mixture of “PVDF–TOA–coconut oil” as liquid



membrane was stable for 98 h. In addition, it was found that coconut oil showed a better performance in the separation of mercury compared to the organic solvents such as dichloroethane and heptane.

## 1.6 Stripping solutions

Types of stripping solutions and their concentrations play a significant role on the transportation of complex species across the interface of liquid membrane-stripping. This is due to the reactions of extraction and stripping in the HFSLM system, which occur simultaneously [85]. The parameters for selecting a suitable stripping agent in order to recover target metal ions from the liquid membrane phase are for example types of extracted target ions (cation, neutral complex, and anion), types of extractants (acidic extractants, chelating extractants, neutral extractants, ligand substitution extractants and basic extractants), and pH of feed and stripping solutions.

An acidic stripping solution is suitable for the recovery of target ions from an acidic extractant or a chelating extractant. In acidic stripping solution, hydrogen ions replace metal cations in the metal complex species. Thus, the metal cations are free and then captured by the stripping solution. In the case of the extraction of neutral metal complexes, a neutral extractant is suitable. Subsequently, neutral metal complexes are removed from the metal complex species by a neutral stripping solution. For the extraction of metal anions, a basic extractant or a neutral extractant is used. Anions from basic stripping solution replace metal anions in the metal complex species and then the target metal ions are released into the stripping solution.

In this work, several types of stripping solutions, as shown in **Table 1.6** ( $\text{NH}_2\text{CSNH}_2$  in  $\text{HCl}$ ,  $\text{NH}_4\text{OH}$ ,  $\text{NH}_4\text{Cl}$ ,  $\text{NaClO}_4$  and  $\text{Na}_2\text{S}_2\text{O}_3$ ) were selected.

**Table 1.6** Stripping agents from previous literature for this work

Name	Application for recovery of precious metals			
	Extractants	Metal ions	Systems	% Stripping
$\text{NH}_2\text{CSNH}_2$	Resins	Pt(IV), Pd(II)& Au(III)	AER[86]	100% Pd(II)
$\text{NaClO}_4$	Alamine 336	Pt(IV), Pd(II), Rh(III)	LLE [32]	75% Pd(II)
$\text{Na}_2\text{S}_2\text{O}_3$	Alamine 336	Ir(IV), Ru(III), Rh(III)	LLE [87]	100%Ir
$\text{NH}_4\text{Cl}$	Dibutyl sulfoxide	Pd(II), Pt(IV)	LLE [88]	99.2% Pd(II)
$\text{NH}_4\text{OH}$	Quaternary phosphonium salt	Pd(II)	AER [89]	90% Pd(II)

**Note:** AER :anion-exchange resins (column chromatographic systems)

### 1.7 Operating temperature in feed and stripping solutions

An increase in dielectric constants of organic solvents results in high solubility of water in liquid membrane phase [90]. This is due to the dielectric constant presenting the capacity of a solvent to produce a dipole force, and forming interaction with water [91]. Furthermore, for all investigated organic solvents, the extraction of target metal ions increased as the operating temperature increased. This can be explained as follows. First, an increase in temperatures of feed and stripping solutions

results in higher temperature of 3 phases of the HFSLM system that encourages easier movement of target metal ions across the liquid membrane.

Secondly, the increase in temperature ensures higher extraction and stripping of target metal ions. The variation of dielectric constants with temperature can be supported the above paragraph [92].

The effect of temperature on the extraction equilibrium ( $K_{ex}$ ) of the target species is directly related to the Van't Hoff equation. This equation is related to the standard Gibbs free energy and the Gibbs–Helmholtz equation [93]. Gibbs free energy change ( $\Delta G_{ex}^0$ ) for Pd(II) extraction can be calculated by Eqs. (1.10) and (1.11):

$$\Delta G_{ex}^0 = -RT \ln K_{ex} \quad (1.10)$$

$$K_{ex} = -\frac{\Delta G_{ex}^0}{RT} \quad (1.11)$$

However, since the activity coefficients have not been incorporated, shifted free energy,  $\Delta G_{ex}^0$ , can be calculated.  $\Delta G_{ex}^0$  is related to the standard enthalpy change  $\Delta H_{ex}^0$  and the standard entropy change  $\Delta S_{ex}^0$  in the Gibbs–Helmholtz equation. The relationship between Gibbs free energy, and the standard enthalpy and entropy changes is described by Eq. (1.12):

$$\Delta G_{ex}^0 = \Delta H_{ex}^0 - T\Delta S_{ex}^0 \quad (1.12)$$

Substituting Eq. (1.12) into Eq. (1.11) results in the Van't Hoff equation in linear form, shown in Eq. (1.13) [94]:

$$\ln K_{ex} = -\frac{\Delta H_{ex}^0}{RT} + \frac{\Delta S_{ex}^0}{R} \quad (1.13)$$

A plot of  $\ln K_{ex}$  versus  $1/T$  should give a straight line, with the standard enthalpy change calculated from the slope. The equilibrium constant is proportional to  $K_{ex}$ . Thus, slope of  $\ln K_{ex}$  versus  $1/T$  plots would yield the standard enthalpy change. Previous work discussed the conditions for the constancy of  $\Delta H_{ex}^0$  and  $\Delta S_{ex}^0$  [95].

The negative enthalpy indicating that the extraction reaction is an exothermic reaction, while the positive enthalpy indicating that the extraction reaction is an endothermic reaction.

The activation energy ( $E_a$ ) is obtained from the Arrhenius equation, Eq. (1.14). Activation energy has a strong effect on the temperature of actual rate constant. The  $E_a$  is always below 20 kJ/mol. It is generally accepted as indicative of pure diffusion-limited transport. If the activation energy is greater than 40 kJ/mol, the chemical reactions play a role in the transport of metal ions across the HFSLM [96-98]. Between 20 kJ/mol and 42 kJ/mol, a mixed diffusion-chemical reaction mechanism is present [99]. The activation energy of the transport of the target species in the HFSLM system is obtained by plotting the flux ( $J$ ) versus ( $1/T$ ) [100], using Eq. (1.15):

$$J = Ae^{-E_a/RT} \quad (1.14)$$

$$\ln J = \ln A - \frac{E_a}{R} \frac{1}{T} \quad (1.15)$$

where  $R$  denotes the universal gas constant (8.314 J/mol·K),  $A$  is the frequency factor, and  $T$  is the absolute temperature (K).

### 1.8 pH of feed and stripping solutions

The suitable pH of feed and stripping solutions play roles in the transport mechanisms of the target species through the HFSLM. The transport mechanisms of the target species are considered as follows [101]:

a) Coupled facilitated counter-transport of metal cations corresponds to the transport of hydrogen ions from the stripping phase to the feed phase. In order to provide the driving force of hydrogen ion transport, the pH of feed and stripping solutions is considered together with the dissociation equilibrium constant (pKa) of the extractant. These values decrease in the following order  $\text{pH}_{\text{feed}} > \text{pKa} > \text{pH}_{\text{stripping}}$

b) Coupled facilitated co-transport of metal anion complexes corresponds to the decomposition of acidic molecules in the feed phase, and the reaction of metal anion complexes with anions in the stripping phase. Thus, the pH of feed solution must be low but the pH of the stripping solution must be high.

### 1.9 Concentration of the extractant

The concentration of the extractant has an influence on the extraction and stripping efficiency of metal ions as well as the diffusion of metal-extractant complexes through liquid membrane phase [44, 45]. Percentage of extraction

increased as the concentration of the extractant increased. However, at higher concentration of the extractant, the percentage of extraction decreased due to an increase in viscosity of liquid membrane. This resulted in mass transfer obstruction in liquid membrane phase, as described in the previous article [102].

### **1.10 Concentration of the stripping solution**

The concentration of the stripping solution as well has an influence on the extraction and stripping efficiency of metal ions. An increase in stripping concentration results in higher extraction and stripping. However, from the study of our group [103], we found that high concentration of the stripping solution greater than 2 M leading to lower extraction and stripping efficiency.

### **1.11 Flow rates of feed and stripping solutions**

Flow rates of feed and stripping solutions in feed and stripping phases influence the contacting time of metal ions with liquid membrane phase. Moreover, the flow rates of feed and stripping solutions influence the stability of liquid membrane phase. An increase in the flow rates increases the extraction and stripping efficiency. However, the extraction and stripping of target metal ions decreases when the flow rates increase due to short residence time of the solutions in the hollow fiber module. High flow rates also lead to loss of liquid membrane from micro-pores of the hollow fibers [104]. The flow rates of feed and stripping solutions must be equal to avoid the difference pressure between the shell and tube sides of the hollow fiber module, which can disturb liquid membrane stability [105].

### 1.12 Transport across hollow fiber supported liquid membrane

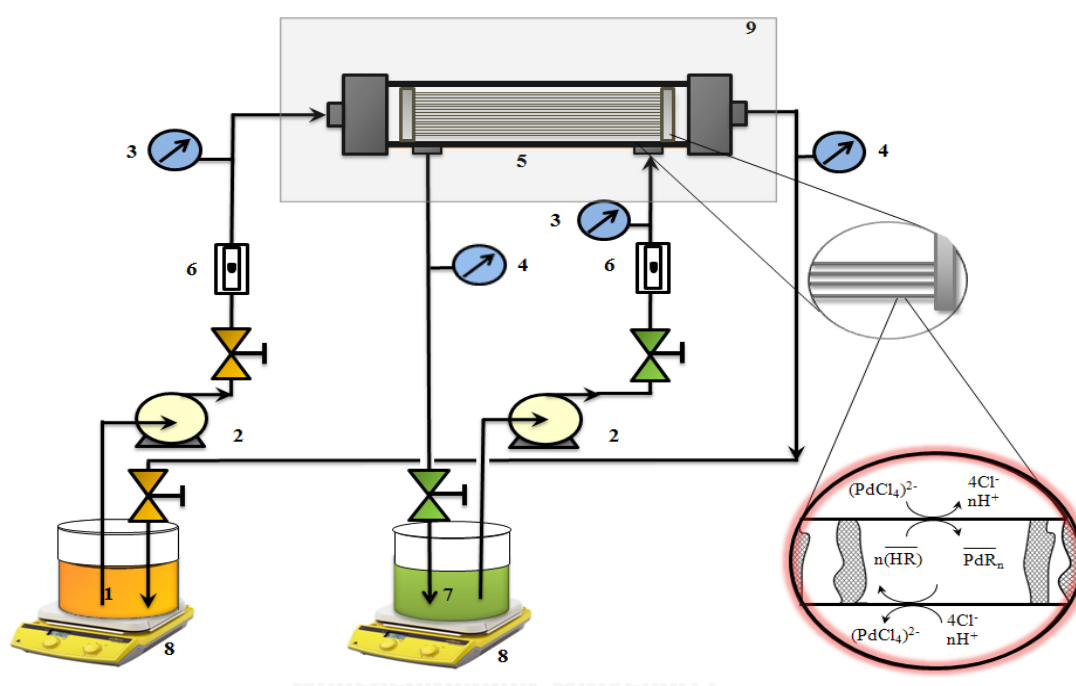
The HFSLM module (a Liqui-Cel®Extra-Flow Laboratory) is made from micro-porous polypropylene woven into fabrics and wrapped around a central-tube feeder to supply the shell side fluid. It is supplied by CELGARD LLC (Charlotte, NC; formerly Hoechst Celanese). This HFSLM module is composed of three phases of feed solution, liquid membrane phase, and stripping solution. The feed and stripping solutions are immiscible with liquid membrane phase. Physical characteristics of the hollow fiber module are shown in **Table 1.7**.

**Table 1. 7** Physical characteristics of the hollow fiber module

Characteristics	Descriptions
Material	polypropylene
Number of fibers	35,000
Fiber inside diameter (cm)	0.024
Fiber outside diameter (cm)	0.03
Effective length (cm)	19.8
Surface area (cm <sup>2</sup> )	1.4 x 10 <sup>4</sup>
Area per unit volume (cm <sup>2</sup> /cm <sup>3</sup> )	29.3
Membrane porosity	25%
Average pore size (cm)	3x10 <sup>-6</sup>
Membrane tortuosity	2.6
Module diameter (cm)	6.3
Module length (cm)	20.3
Operating temperature (K)	273 – 333

A single hollow fiber module operation for the extraction and stripping of target metal ions (palladium(II)) is shown in **Fig. 1.2**. The separation mechanism consisted of three steps. The first step is the preparation of the HFSLM module by feeding organic solution (extractant dissolved in organic solvent) into the tube side of

the hollow fiber module for 40 min to ensure that the extractant is embedded into the micro pores of the hollow fibers. The second step was simultaneously pumping the feed solution into the tube side and stripping solution into the shell side of the HFSLM module in a counter-current flow pattern. Finally, samples from the feed and stripping solutions were taken every 10 min for 60 min and the concentrations of palladium(II) in the samples were determined by ICPS-7000.



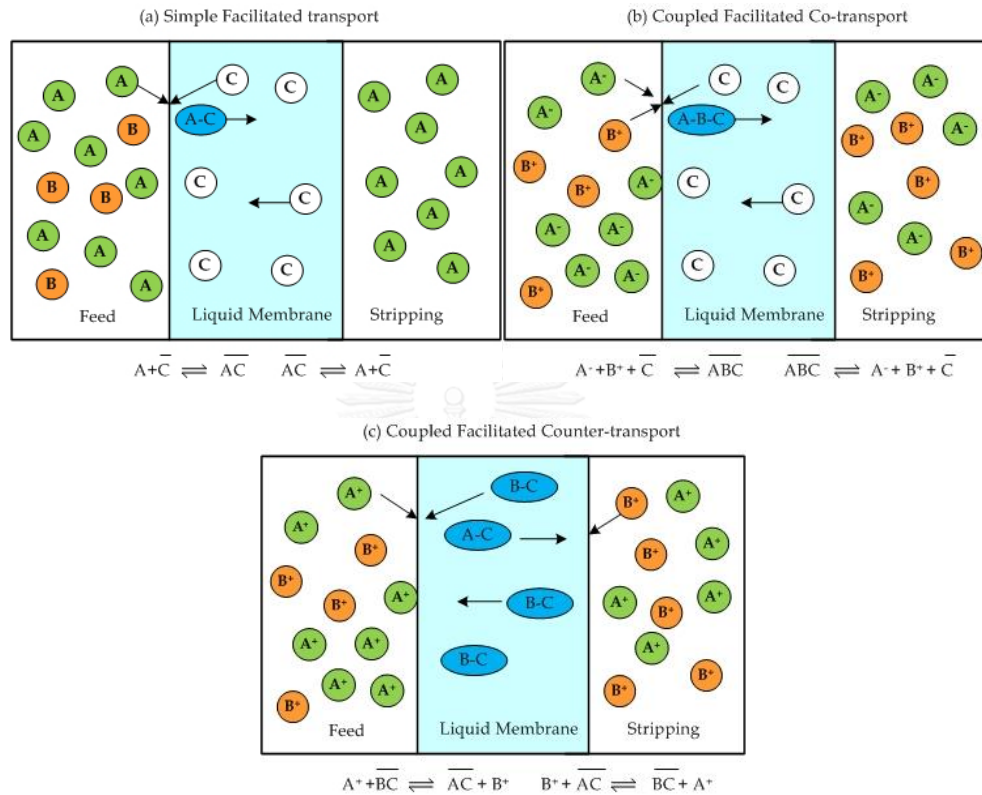
**Fig.1. 2** Schematic counter-current flow diagram for a single-module operation in the HFSLM system: 1) feed reservoir 2) gear pumps 3) inlet pressure gauges 4) outlet pressure gauges 5) hollow fiber module 6) flow meters 7) stripping reservoir 8) stirrer with temperature control and 9) temperature control box



Transportation of palladium(II) across the HFSLM module is shown in **Fig.1.2**. Palladium(II) in the feed solution diffuses to the interface of the feed - liquid membrane phases. Then, palladium(II) reacts with the selected extractant at this interface to generate complex species. After that, the complex species transport to the interface of the liquid membrane-stripping phases by the concentration gradient. No transport of palladium(II) across liquid membrane is assumed. This complex species reacts with the stripping solution at the interface of the liquid membrane-stripping phases. Thus, the complex species is released into the stripping phase. Finally, palladium(II) is transferred into the stripping phase, while the extractant returns to the liquid membrane and transfers to the interface of feed and liquid membrane. The extractant reacts once again with palladium(II) at this interface.

**Fig. 1.3** schematically explains the transport of each case. The descriptive drawing depicts (A) = the target metal ions (B) = co-ions (C) = the organic extractant, and ( $\overline{AC}$ ,  $\overline{BC}$  or  $\overline{ABC}$ ) = the organic complex species. In our study, the target metal ions (A) can be palladium(II) or platinum(IV). The straightforward mechanism is observed with the simple facilitated transport (**Fig. 1.3 (a)**) since the organic complex species ( $\overline{AC}$ ) is produced from the reaction between (A) and (C). Then,  $\overline{AC}$  is decomposed at the interface between the liquid membrane and the stripping phase, and (A) is recovered to the stripping solution. The coupled facilitated transport can be classified into co-transport (**Fig. 1.3 (b)**) and counter-transport (**Fig. 1.3 (c)**). For the coupled facilitated co-transport, the extractant reacts with the target metal ions (A) and co-ion (B) to form the organic complex species ( $\overline{ABC}$ ). Then,  $\overline{ABC}$  diffuses across the liquid membrane to the stripping interface where both the target metal ions

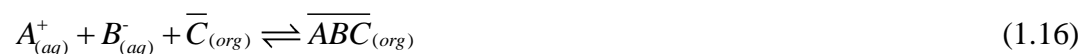
and co-ions are simultaneously recovered. This mechanism has co-ion transporting along with the target component from feed phase to stripping phase.



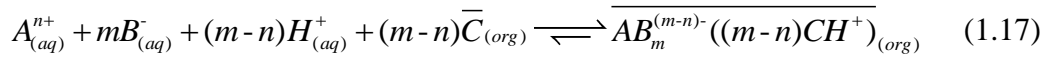
**Fig.1. 3** The descriptive drawing of liquid membrane system [106]

This coupled facilitated co-transport is common for both neutral and basic organic extraction as schematized in Eq. (1.16) for the reaction with neutral organic extractant and Eq. (1.17) for the reaction with the basic organic extractant. The aqueous pH phase or hydrogen ion in the system is depicted by (H).

Coupled co-transport with neutral organic extractant in the system:



Coupled co-transport with basic organic extractant in the system:



The coupled facilitated counter-transport has reverse mechanism from the co-transport. The co-ion (B) transports from the stripping phase to feed phase, against the transport direction of the target metal ions (A). The mechanism starts with the reaction between (A) and the organic extractant ( $\overline{BC}$ ) to form organic complex ( $\overline{AC}$ ) and releases co-ion (B) to the feed phase. Subsequently, the organic complex ( $\overline{AC}$ ) diffuses across the liquid membrane to the stripping interface where the target metal ions are released to the stripping phase and co-ion is recovered to the organic extractant. The common case of counter-transport is the reaction using acidic extractant as schematized by Eq. (1.18).

Coupled counter-transport, acidic organic extractant:



### 1.13 Objectives of the dissertation

1. To investigate the effect of operating conditions on the extraction and stripping of palladium(II) from the flexible printed circuit board (FPCB) wastewater and platinum(IV) from gold refining (GR) wastewater via HFSLM

2. To study the potential of using natural solvents for organic solvents on the extraction and stripping of platinum(IV) from gold refining wastewater via HFSLM system
3. To apply the mathematical model based on diffusion, the reaction at the interface of feed and liquid membrane phases, and the accumulation of the metal ions in liquid membrane phase to estimate the extraction of palladium(II) from the flexible printed circuit board wastewater across HFSLM

#### **1.14 Scope of the dissertation**

1. To investigate the influences of operating conditions on the extraction and stripping of palladium(II) from flexible printed circuit board wastewater
2. To investigate the influences of operating conditions on the extraction and stripping of platinum(IV) from gold refining wastewater
3. To apply the natural solvents, i.e., sunflower oil, coconut oil and soybean oil in the separation of platinum from gold refining wastewater
4. To compare the theoretical mass transfer from the extraction of palladium(II) from flexible printed circuit board wastewater estimated by the mathematical model with the experimental data

Operating conditions in this work are listed in **Tables 1.8** and **1.9**.

**Table 1. 8** Investigated operating conditions for the extraction and stripping of palladium(II) from flexible printed circuit board wastewater

Parameters	
1. pH of feed solution	1-6
2. Concentration of palladium	5-500 ppm
3. Types of extractants	LIX 84-I, TBP and Cyanex 471
4. Concentration of extractants	2-15 %(v/v)
5. Types of organic solvents	hexane, xylene, cyclohexane, benzene, chlorobenzene, 1,2-dichloromethane, dodecane, chloroform and kerosene
6. Types of stripping solution	H <sub>2</sub> SO <sub>4</sub> , HCl, NH <sub>2</sub> CSNH <sub>2</sub> , NH <sub>4</sub> Cl, and the mixture of NH <sub>2</sub> CSNH <sub>2</sub> and HCl
7. Concentration of stripping solution	0.1-1.2 M
8. Operating time	10-120 min
9. Operating temperature	303-323 K
10. Stability of the liquid membrane	60-400 min

**Table 1. 9** Investigated operating conditions for the extraction and stripping of platinum (IV) from gold refining wastewater

Parameters	
1. pH of feed solution	1-6
2. Types of extractants	Aliquat 336, LIX84, Cyanex 923, TBP and TOPO
3. Concentration of extractants	2-15 % (v/v)
4. Types of organic solvents	hexane, xylene, cyclohexane, benzene, chlorobenzene, 1,2-dichloromethane, dodecane, chloroform and kerosene
5. Types of natural solvents	coconut oil, soybean oil and sunflower oil
6. Types of stripping solution	HCl, $\text{NH}_2\text{CSNH}_2$ , $\text{NH}_4\text{Cl}$ , and the mixture of $\text{NH}_2\text{CSNH}_2$ and HCl
7. Concentration of stripping solution	0.1-1.2 M
8. Operating time	10-120 min
9. Operating temperature	303-323 K

### 1.15 Expected results

1. High extraction and stripping of palladium (II) and platinum (IV) from industrial wastewaters
2. Known natural solvent yielding the highest extraction of platinum (IV) from gold refining wastewater

3. Validation of the mathematical model based on diffusion, the reaction at the interface of feed and liquid membrane phases, and the accumulation of the metal ions in liquid membrane phase to the estimation of the extraction of the target metal ions across the HFSLM module

### **1.16 Description of the dissertation**

This dissertation is divided into 6 Chapters. Chapter I encompasses a brief introduction and rationale of work. Chapters II–V involve with the articles concerning the research on the separation of palladium(II) from the flexible printed circuit board wastewater and platinum(IV) from gold refining wastewater. Chapter VI summarizes the conclusion of this dissertation. Chapters II–V are outlined as follows:

#### **Chapter II**

This chapter focused on the separation of Pd(II) from the FPCB wastewater. Results indicated that in the HFSLM, the suitable type of organic solvent facilitate extractant for the separation of palladium. The polarity of the organic solvent plays important role in the extraction and stripping of palladium, and membrane stability. High Pd(II) extraction and stripping of 96% and 91%, respectively were observed at feed solution pH 2, 5% (v/v) LIX84–I dissolved in kerosene as the extractant, a mixture of 0.8 M  $\text{NH}_2\text{CSNH}_2$  with 1 M HCl as the stripping solution, and equal flow rates of feed and stripping solutions of 100 mL/min. Highest membrane stability was attained at 350 min using hexane as a solvent. The calculated activation energy ( $E_a$ ) was 30 kJ/mol implying that the separation of Pd(II) was controlled by the diffusion

and chemical reaction. Details are available in the published article of Journal of Industrial and Engineering Chemistry (pp: 212-220). Vol. 21. 2015 [107].

### **Chapter III**

This chapter highlighted the purification of Sn(IV) and recovery of Pd(II) from flexible printed circuit board wastewater via HFSLM. This work examined the influences of extractant concentration in the liquid membrane, HCl concentration, and flow rates of feed and stripping solutions. The thermodynamic properties were also investigated. The extraction of Pd(II) and purification of Sn(IV) were 100% and 84%, respectively. Purification of Sn(IV) remained in the feed solution. Pd(II) and Sn(IV) kinetic reaction orders approached 1.0, and the reaction rate constants were 0.08509 and 0.00301 min<sup>-1</sup>, respectively. The experimental results agreed well with the calculated results from the mathematical model with the deviation less than 5%. Details are available in the published article of Journal of Industrial and Engineering Chemistry (pp: 217-228). Vol. 22. 2015 [108].

### **Chapter IV**

This chapter studied mass transfer resistance and response surface methodology for the separation of platinum(IV) from gold refining wastewater across HFSLM. Successful results of 96% Pd(IV) extraction and 88% stripping were attained by using 10%(v/v) trioctylmethyl-ammonium chloride (Aliquat 336) as the extractant. The mass transfer resistances were  $(1/k_a)$   $3.297 \times 10^4$  s/cm,  $(1/k_m)$   $0.164 \times 10^4$  s/cm,



( $1/k_o$ )  $3.404 \times 10^4$  s/cm, and ( $1/K$ )  $6.865 \times 10^4$  s/cm. The system was governed by the mass transfer resistance from the liquid membrane. Response surface methodology was used to qualify and estimate the influences of operating conditions. The predicted model was in good agreement with the experimental data at a standard deviation of 1%. Details are available in the published article of Journal of Industrial and Engineering Chemistry (pp: 23-35). Vol: 42. 2016 [109].

## Chapter V

This chapter explored the effects of natural solvents (non-toxic diluents) and organic solvents (conventional diluents) on the separation of platinum(IV) from gold refining wastewater across HFSLM. Consequently, 91% extraction and 81% stripping of Pd(IV) were observed by using sunflower oils at 328.15 K. The overall mass transfer resistance ( $R$ ) was  $146.612 \times 10^4$  s/cm. The separation process was endothermic ( $\Delta H_{ex}^0 = 98.804$  kJ/mol) and spontaneous ( $\Delta G_{ex}^0 = -37.822$  kJ/mol). The  $E_a$  of 1.673 kJ/mol indicated that the diffusion of complex species across the liquid membrane controlled the mass transfer step. Moreover, a modified Apelblat model gave an excellent match for predicting the extraction behavior of Pt(IV) at 1.28% RMSD. Details are available in the published article of Journal of Industrial and Engineering Chemistry. (pp: 278-289). Vol. 54. 2017 [110].

### 1.17 References

- [1] D. Afzali, R. Jamshidi, S. Ghaseminezhad, Z. Afzali, *Arabian J. Chem.*, 5 (2012) 461-466.
- [2] A. Uheida, Y. Zhang, M. Muhammed, *J. Membr. Sci.*, 241 (2004) 289-295.
- [3] T. Gebel, H. Lantzsch, K. Pleßow, H. Dunkelberg, *Mutat Res-Gen Tox En* 389 (1997) 183-190.
- [4] A. Dakshinamoorthy, P.S. Dhami, P.W. Naik, N.L. Dudwadkar, S.K. Munshi, P.K. Dey, V. Venugopal, *Desalination*, 232 (2008) 26-36.
- [5] I.M. Ahmed, A.A. Nayl, J.A. Daoud, *Int J Miner Process*, 101 (2011) 89-93.
- [6] Z. Hubicki, M. Leszczyńska, B. Łodyga, A. Łodyga, *Miner. Eng.*, 19 (2006) 1341-1347.
- [7] B. Godlewska-Żyłkiewicz, *Spectrochim. Acta, Part B*, 58 (2003) 1531-1540.
- [8] H. Ebrahimzadeh, N. Tavassoli, M.M. Amini, Y. Fazaeli, H. Abedi, *Talanta*, 81 (2010) 1183-1188.
- [9] B. Gupta, I. Singh, *Hydrometallurgy*, 134 (2013) 11-18.
- [10] B. Swain, J. Jeong, S.-k. Kim, J.-c. Lee, *Hydrometallurgy*, 104 (2010) 1-7.
- [11] C. Fontas, C. Palet, V. Salvado, M. Hidalgo, *J Membrane Sci*, 178 (2000) 131-139.
- [12] F.F. Zha, A.G. Fane, C.J.D. Fell, *Journal of Membrane Science*, 107 (1995) 59-74.
- [13] I. Akin, S. Erdemir, M. Yilmaz, M. Ersoz, *J Hazard Mater*, 223 (2012) 24-30.
- [14] C. Fontas, E. Antico, F. Vocanson, R. Lamartine, P. Seta, *Sep Purif Technol*, 54 (2007) 322-328.

- [15] M. Rovira, J.L. Cortina, A.M. Sastre, *Solvent Extr Ion Exc*, 17 (1999) 333-349.
- [16] A. Zaghbani, R. Tayeb, M. Dhahbi, M. Hidalgo, F. Vocansonc, I. Bonnamour, P. Seta, M.A. Fontas, *Sep Purif Technol*, 57 (2007) 374-379.
- [17] A.T. Yordanov, J.T. Mague, D.M. Roundhill, *Inorg Chim Acta*, 240 (1995) 441-446.
- [18] A. Uheida, Y. Zhang, M. Muhammed, *Journal of Membrane Science*, 241 (2004) 289-295.
- [19] E. Antico, A. Masana, M. Hidalgo, V. Salvado, M. Valiente, *Hydrometallurgy*, 35 (1994) 343-352.
- [20] S. Rastegarzadeh, N. Pourreza, A.R. Kiasat, H. Yahyavi, *Microchim Acta*, 170 (2010) 135-140.
- [21] J.Y. Lee, J.R. Kumar, J.S. Kim, D.J. Kim, H.S. Yoon, *J Ind Eng Chem*, 15 (2009) 359-364.
- [22] T.R. Reddy, N.N. Meeravali, A.V.R. Reddy, *Sep Purif Technol*, 103 (2013) 71-77.
- [23] B. Raju, J.R. Kumar, J.-Y. Lee, H.-S. Kwonc, M.L. Kantam, B.R. Reddy, *J. Hazard. Mater.*, 227–228 (2012) 142-147.
- [24] M.C. Costa, A. Assuncao, A.M.R. da Costa, C. Nogueira, A.P. Paiva, *Solvent Extr Ion Exc*, 31 (2013) 12-23.
- [25] A.M. Yousif, M. Nishioka, Y. Wakui, T.M. Suzuki, *Solvent Extr Ion Exc*, 30 (2012) 77-87.
- [26] C. Fontas, M. Hidalgo, V. Salvado, *Solvent Extr Ion Exc*, 27 (2009) 83-96.
- [27] A. Zaghbani, R. Tayeb, M. Dhahbi, M. Hidalgo, F. Vocansonc, I. Bonnamour, P. Seta, M.A. Fontas, *Sep. Purif. Technol.*, 57 (2007) 374-379.

- [28] M. Trautmann, H.J. Holdt, *Sep Purif Technol*, 149 (2015) 279-287.
- [29] C. Zhang, K. Huang, P.H. Yu, H.Z. Liu, *Sep Purif Technol*, 108 (2013) 166-173.
- [30] B. Swain, J. Jeong, S.K. Kim, J.C. Lee, *Hydrometallurgy*, 104 (2010) 1-7.
- [31] J.R. Kumar, H.I. Lee, J.Y. Lee, J.S. Kim, J.S. Sohn, *Sep Purif Technol*, 63 (2008) 184-190.
- [32] P.P. Sun, M.S. Lee, *Hydrometallurgy*, 109 (2011) 181-184.
- [33] P.P. Sun, J.Y. Lee, M.S. Lee, *Hydrometallurgy*, 113 (2012) 200-204.
- [34] J.Y. Lee, J.R. Kumar, J.S. Kim, H.K. Park, H.S. Yoon, *J Hazard Mater*, 168 (2009) 424-429.
- [35] P.P. Sun, J.Y. Lee, M.S. Lee, *Mater Trans*, 52 (2011) 2071-2076.
- [36] A.N. Nikoloski, K.L. Ang, D. Li, *Hydrometallurgy*, 152 (2015) 20-32.
- [37] W. Wei, C.W. Cho, S. Kim, M.H. Song, J.K. Bediako, Y.S. Yun, *J Mol Liq*, 216 (2016) 18-24.
- [38] T.H. Nguyen, C.H. Sonu, M.S. Lee, *J Ind Eng Chem*, 32 (2015) 238-245.
- [39] S. Suren, U. Pancharoen, N. Thamphiphit, N. Leepipatpiboon, *J Membrane Sci*, 448 (2013) 23-33.
- [40] A. Kumar, R. Haddad, G. Benzal, R. Ninou, A.M. Sastre, *Journal of Membrane Science*, 174 (2000) 17-30.
- [41] J. Markoš, Chapter 9: Roles of Facilitated Transport Through HFSLM in *Engineering Applications InTech*, (2011).
- [42] T. Prapasawat, A.W. Lothongkum, U. Pancharoen, *Chem Pap*, 68 (2014) 180-189.
- [43] P. Kandwal, S.A. Ansari, P.K. Mohapatra, *J Membrane Sci*, 405 (2012) 85-91.
- [44] C. Fontas, V. Salvado, M. Hidalgo, *J Membrane Sci*, 223 (2003) 39-48.

- [45] S. Chaturabul, K. Wongkaew, U. Pancharoen, *Separ Sci Technol*, 48 (2013) 93-104.
- [46] M.S. Manna, P. Saha, A.K. Ghoshal, *J Membrane Sci*, 471 (2014) 219-226.
- [47] D.H. Kim, I.H. Baek, S.U. Hong, H.K. Lee, *J Membrane Sci*, 372 (2011) 346-354.
- [48] W.D. Zhang, C.H. Cui, Z.S. Hao, *Chinese J Chem Eng*, 18 (2010) 48-54.
- [49] A. Bhattacharyya, S.A. Ansari, P. Kandwal, P.K. Mohapatra, V.K. Manchanda, *Separ Sci Technol*, 46 (2011) 205-214.
- [50] V.C. Adya, A. Sengupta, S. Ansari, P.K. Mohapatra, M.K. Bhide, S.V. Godbole, *J Radioanal Nucl Ch*, 295 (2013) 1023-1028.
- [51] T. Barri, T. Trtic-Petrovic, M. Karlsson, J.A. Jonsson, *J Pharmaceut Biomed*, 48 (2008) 49-56.
- [52] A.M. Msagati, *Comp Biochem Phys A*, 151 (2008) S51-S51.
- [53] (<http://www.lenntech.com/periodic/elements/pd.htm> (accessed 27-07-2017)).
- [54] (<http://www.lenntech.com/periodic/elements/pt.htm> (accessed 27-07-2017)).
- [55] M.R.S.E.R.a.A. Cognis: *Mining Chemicals Technology*, 1-73, Cognis Group, 2007.
- [56] Y.J. Qin, J.M.S. Cabral, *J Chem Technol Biot*, 65 (1996) 137-148.
- [57] A. Manuel, L.C. Jose, in *Solvent extraction and membranes, fundamentals and applications in new materials*, CRC Press, the United States of America (2008).
- [58] I. Van de Voorde, K. Latruwe, L. Pinoy, E. Courtijn, F. Verpoort, *Solvent Extr Ion Exc*, 25 (2007) 809-829.
- [59] B.R. Reddy, B. Raju, J.Y. Lee, H.K. Park, *J Hazard Mater*, 180 (2010) 253-258.
- [60] MCT.

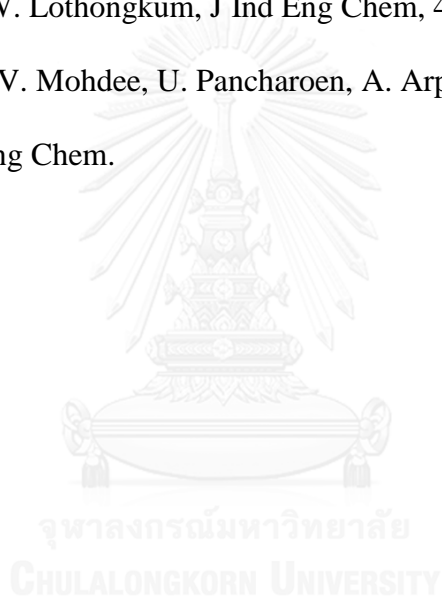
- [61] M.V. Rane, V. Venugopal, *Hydrometallurgy*, 84 (2006) 54-59.
- [62] C. Foulon, D. Pareau, G. Durand, *Hydrometallurgy*, 51 (1999) 139-153.
- [63] C.Y. Peng, T.H. Tsai, *Desalin Water Treat*, 47 (2012) 105-111.
- [64] M. Rovira, L. Hurtado, J.L. Cortina, J. Arnaldos, A.M. Sastre, *React Funct Polym*, 38 (1998) 279-287.
- [65] C. Fontas, V. Salvado, M. Hidalgo, *Solvent Extr Ion Exc*, 17 (1999) 149-162.
- [66] H.H. Nejad, S.S. Zadeh, S. Alam, *Can Metall Quart*, 52 (2013) 342-347.
- [67] S.N. Duche, P.M. Dhadke, *Sep Sci Technol*, 37 (2002) 3011-3024.
- [68] K. Wongkaew, N. Sunsandee, U. Pancharoen, K. Nootong, P. Ramakul, *J Ind Eng Chem*, 22 (2015) 217-228.
- [69] K. Wongkaew, U. Pancharoen, S. Phatanasri, N. Leepipatpiboon, A.W. Lothongkum, *J Ind Eng Chem*, 21 (2015) 212-220.
- [70] T.Z. Sadyrbaeva, *Separ Sci Technol*, 41 (2006) 3213-3228.
- [71] K. Wongkaew, T. Wannachod, V. Mohdee, U. Pancharoen, A. Arpornwichanop, A.W. Lothongkum, *J Ind Eng Chem*.
- [72] F.J. Alguacil, C. Caravaca, M.I. Martin, *J Chem Technol Biot*, 78 (2003) 1048-1053.
- [73] P.K. Kuipa, M.A. Hughes, *Separ Sci Technol*, 37 (2002) 1135-1152.
- [74] K.S.R. T.H. Lowry, Chapter 2: some fundamentals of physic organic chemistry, in: T.H. Lowry, K.S. Richardson (Eds.), *Mechanism and Theory in Organic Chemistry*, 57-123, New York: Harper and Row, Publishers, Inc., 1976.
- [75] R.A.S. E. Buncl, H. Wilson, The solvent as medium, in: E. Buncl, R.A. Stairs, H. Wilson (Eds.), *The role of the solvent in chemical reactions*, 159, New York: Oxford University Press, Inc., 2003.

- [76] K. Wang, Z.D. Chang, Y.C. Ma, C. Lei, S.C. Jin, Y. Wu, I. Mahmood, C. Hua, H.Z. Liu, *Fluid Phase Equilib*, 278 (2009) 103-108.
- [77] G.H. Yang, M.S. Jahan, L. Ahsan, Y.H. Ni, *Sep Purif Technol*, 120 (2013) 341-345.
- [78] A.P. de los Rios, F.J. Hernandez-Fernandez, F. Tomas-Alonso, J.M. Palacios, G. Villora, *Desalination*, 245 (2009) 776-782.
- [79] N. Leepipatpiboon, U. Pancharoen, P. Ramakul, *Korean J Chem Eng*, 30 (2013) 194-200.
- [80] S. Shailesh, P.N. Pathak, P.K. Mohapatra, V.K. Manchanda, *Desalination*, 232 (2008) 281-290.
- [81] S.H. Chang, T.T. Teng, N. Ismail, *J Hazard Mater*, 181 (2010) 868-872.
- [82] K. Chakrabarty, P. Saha, A.K. Ghoshal, *J Membrane Sci*, 350 (2010) 395-401.
- [83] P. Kazemi, M. Peydayesh, A. Bandegi, T. Mohammadi, O. Bakhtiari, *Chem Pap*, 67 (2013) 722-729.
- [84] P. Venkateswaran, A.N. Gopalakrishnan, K. Palanivelu, *J Environ Sci-China*, 19 (2007) 1446-1453.
- [85] N. Sunsandee, N. Leepipatpiboon, P. Ramakul, T. Wongsawa, U. Pancharoen, *Sep Purif Technol*, 102 (2013) 50-61.
- [86] I. Matsubara, Y. Takeda, K. Ishida, *Fresen J Anal Chem*, 366 (2000) 213-217.
- [87] E. Goralska, M.T. Coll, A. Fortuny, C.S. Kedari, A.M. Sastre, *Solvent Extr Ion Exc*, 25 (2007) 65-77.
- [88] L. Pan, Z.D. Zhang, *Miner Eng*, 22 (2009) 1271-1276.
- [89] A. Cieszynska, M. Wisniewski, *Hydrometallurgy*, 113 (2012) 79-85.

- [90] W. Srirachat, T. Wongsawa, N. Sunsandee, U. Pancharoen, S. Kheawhom, *Fluid Phase Equilib*, 401 (2015) 34-47.
- [91] M. Valisko, D. Boda, *Condens Matter Phys*, 8 (2005) 357-376.
- [92] Landolt-Börnstein, Springer-Verlag, Berlin, (1991).
- [93] F. Angulo-Brown, L.A. Arias-Hernández, *The Journal of Physical Chemistry*, 100 (1996) 9193-9195.
- [94] S.V. Yadav, V.V. Mahajani, *Sep Sci Technol*, 42 (2007) 1283-1303.
- [95] E.O. Otu, *Thermochim. Acta*, 329 (1999) 117-121.
- [96] P.A. O'Hara, M.P. Bohrer, *J. Membr. Sci.*, 44 (1989) 273-287.
- [97] J.M. Zhao, W. Li, D.Q. Li, Y. Xiong, *Solvent Extr Ion Exc*, 24 (2006) 165-176.
- [98] R. Davarkhah, F. Khanramaki, M. Asgari, B. Salimi, P. Ashtari, M. Shamsipur, *J Radioanal Nucl Ch*, (2013) 1-8.
- [99] W. Liao, G. Yu, S. Yue, D. Li, *Talanta*, 56 (2002) 613-618.
- [100] P. Peng, A.G. Fane, X. Li, *Desalination*, 173 (2005) 45-54.
- [101] T. Wannachod, V. Mohdee, S. Suren, P. Ramakul, U. Pancharoen, K. Nootong, *J Ind Eng Chem*, 26 (2015) 214-217.
- [102] C. Fontàs, C. Palet, V. Salvadó, M. Hidalgo, *J Membrane Sci.*, 178 (2000) 131-139.
- [103] T. Pirom, K. Wongkaew, T. Wannachod, U. Pancharoen, N. Leepipatpiboon, *J Ind Eng Chem*.
- [104] N. Leepipatpaiboon, U. Pancharoen, N. Sunsandee, P. Ramakul, *Korean J Chem Eng*, (2014) 1-7.
- [105] P.C. Rout, K. Sarangi, *Sep Purif Technol*, 122 (2014) 270-277.



- [106] M.S.R.a. E. Bringas, JA. Irabien and I. Ortiz, In: J. Chem Technol Biotechnol, 84 (2009) 1583-1614.
- [107] K. Wongkaew, U. Paricharoen, S. Phatanasri, N. Leepipatpiboon, A.W. Lothongkum, J Ind Eng Chem, 21 (2015) 212-220.
- [108] K. Wongkaew, N. Sunsandee, U. Pancharoen, K. Nootong, P. Ramakul, J Ind Eng Chem, 22 (2015) 217-228.
- [109] K. Wongkaew, T. Wannachod, V. Mohdee, U. Pancharoen, A. Arpornwichanop, A.W. Lothongkum, J Ind Eng Chem, 42 (2016) 23-35.
- [110] K. Wongkaew, V. Mohdee, U. Pancharoen, A. Arpornwichanop, A.W. Lothongkum, J Ind Eng Chem.



## CHAPTER II

Effect of diluent polarity on membrane stability in the separation of trace Pd(II) from wastewater by HFSLM using LIX84-I

Kraiwith Wongkaew<sup>a</sup>, Ura Pancharoen<sup>a</sup>, Suphot Phatanasri<sup>a\*</sup>, Natchanun Leepipatpiboon<sup>b\*\*</sup>, Anchaleeporn W. Lothongkum<sup>c</sup>

a: Department of Chemical Engineering, Faculty of Engineering, Chulalongkorn University, Pathumwan Bangkok 10330, Thailand

b: Chromatography and Separation Research Unit, Department of Chemistry, Faculty of Science, Chulalongkorn University, Patumwan, Bangkok 10330, Thailand

c: Department of Chemical Engineering, Faculty of Engineering, King Mongkut's Institute of Technology Ladkrabang, Bangkok 10520, Thailand

จุฬาลงกรณ์มหาวิทยาลัย  
CHULALONGKORN UNIVERSITY

---

This article has been published in Journal: Journal of Industrial and Engineering Chemistry. (Page: 212-220). Volume: 21. Year:2015

---

## 2.1 Abstract

In a liquid membrane, the type of diluents for the selected extractant plays an important role in membrane stability and separation efficiency. High Pd(II) extraction and stripping of 96% and 91%, respectively, were observed by HFSLM under a feed pH 2, 5% (v/v) LIX84–I dissolved in kerosene and a mixture of 0.8 M  $\text{NH}_2\text{CSNH}_2$  with 1 M HCl as a stripping solution. The highest stability was attained at 350 min by using hexane as a diluent. Finally, the calculated activation energy ( $E_a$ ) of 30 kJ/mol implied that the separation of Pd(II) was controlled by the diffusion and chemical reaction.

*Keywords:* Palladium; Diluent; Polarity; HFSLM; Membrane stability; LIX 84–I

\*Corresponding author. Tel.: +66 2 2186893; fax: +66 2 2186877.

E-mail address: s\_phatanasri@yahoo.com (S. Phatanasri).

\*\*Corresponding author. Tel.: +66 2 2187608; fax: +66 2 2541309.

E-mail address: natchanun.l@chula.ac.th (N. Leepipatpiboon).

## 2.2 Introduction

Palladium, a rare noble element, has special physical and chemical properties, such as high melting point, catalytic activities and corrosion resistance. Palladium is low in abundance and fetches a high price. Pure palladium and its alloys have been extensively used in many applications: contacts, grids for electronic tubes, telephone circuits, electrical relays and switching systems in telecommunication equipment, heat

and corrosion resistance apparatus, resistance wires, and catalytic converters [1, 2]. In the flexible printed circuit board (FPCB) industry, palladium is used in the direct plating process (DPP). After finishing the process, trace amounts of palladium ions, Pd(II) approximately 100–400 mg/L are found in the wastewater. Palladium can affect the growth and health of living beings. For example, PdCl<sub>2</sub> at 5 ppm in drinking water has an adverse impact on human health [3]. Therefore, it is important to separate palladium from wastewater.

Conventional methods for separating Pd(II) from aqueous solutions are precipitation [4], solvent extraction [5], ion exchange [6], bio-adsorption [7] and adsorption [8]. However, these methods possess both advantages and disadvantages [9-13]. To overcome a major shortcoming of these conventional methods i.e. inefficient separation of the target species at a very low concentration (ppm or ppb level), a hollow fiber supported liquid membrane (HFSLM) can be applied. HFSLM has a high membrane interfacial surface area per unit volume, and can simultaneously extract and strip the target species in one single-step operation [14, 15]. Literature reviews of HFSLM applications for the separation of metal ions are described elsewhere [16-18].

Although the HFSLM system has been widely studied for the separation of metal ions, it has its limitation regarding insufficient liquid membrane stability. This limitation can be due to the loss of the extractant and/or diluent from the micropores of the hollow fibers. Parameters affecting the stability of the liquid membrane, as previously reported [19], are type of extractants as well as type of diluents. The separation of platinum-group metals, in particular Pd(II) and Pt(IV), has been extensively investigated by many researchers. These experiments mostly concerned

synthetic wastewater at low metal concentrations and employed extractants such as 2-hydroxy-5-nonylacetophenone oxime (LIX84-I) which has high efficiency and excellent selectivity [20]. Rane and Venugopal [21] extracted Pd(II) and Pt(IV) using LIX84-I dissolved in dodecane via solvent extraction. The stripping percentages of Pd(II) and Pt(IV) were 97% and 86%, respectively. Reddy et al. [22] also extracted Pd(II) and Pt(IV) using LIX84-I and Alamine336 dissolved in kerosene, employing solvent extraction; the stripping of Pd(II) and Pt(IV) was higher than 99%. Alkyl phosphines, in particular triisobutylphosphine sulfide (TIBPS), are becoming popular as extractants for metal ions due to their poor aqueous solubility, good hydrolytic stability and selectivity [23]. TIBPS was applied to extract Pd(II), as in a previously published report [24]. Tri-*n*-butyl phosphate (TBP) is a neutral extractant classified as a soft base, which can react with anions and cations in the solution. TBP shows high performance of Pd(II) extraction, as reported elsewhere [25].

In order to prolong the stability of the liquid membrane, different types of diluents are considered for sufficient miscibility in the chosen extractant in the diluents. Appropriate diluents should meet certain requirements e.g. high solubility in water, high interfacial tension between the solvent and water phases, low volatility, low viscosity, little tendency to react with metal ions, low toxicity, and low cost [19, 26]. The polarity of diluents is also a parameter which can affect the stability of the liquid membrane. Leepipatpiboon et al. [27] reported the influence of diluent polarity on the stability of liquid membrane in the HFSLM system for Co(II) and Ni(II) separation by using Alamine300 as the extractant and different diluents. Their results demonstrated that high polarity (polarity indexes  $\geq 3.5$ ) of diluents bring about high extraction performance but low stability. Further, Sunsandee et al. [28] reported on

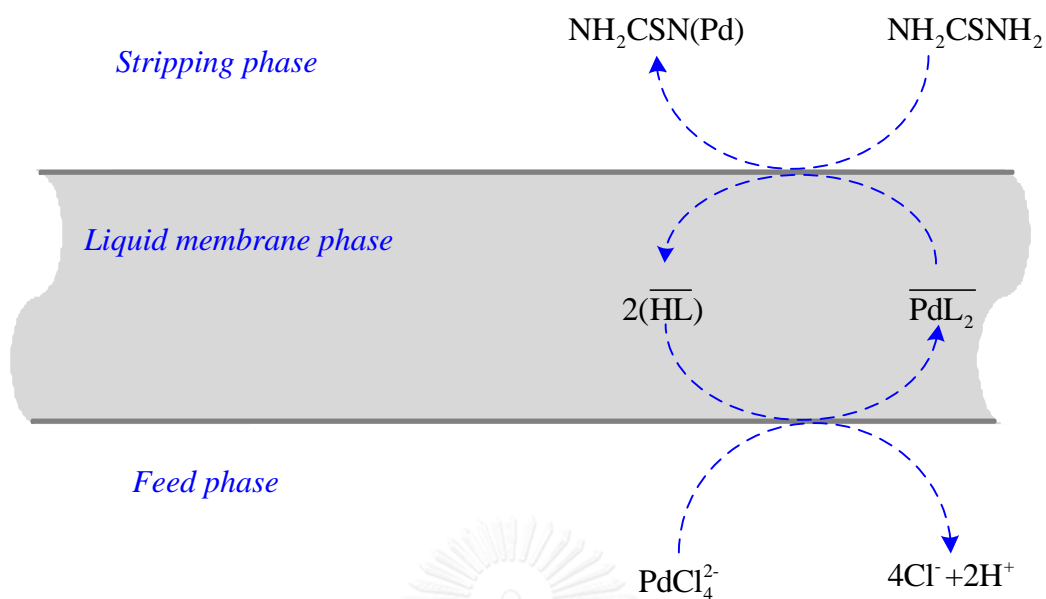
the extraction of (S)-amlodipine by using DBTA as the extractant and various diluents in the HFSLM system. The results revealed that benzene, which has a polarity index of 2.7, provided the best compromise between extraction performance and liquid membrane stability. The increasing polarity of diluents causes an increase in the solubility of the liquid membrane in the aqueous solutions. This leads to instability of the liquid membrane. Thus, the stability of the liquid membrane depends significantly on the diluent chosen. However, to the best of our knowledge, no literature has reported on the influence of diluent polarity on the stability of liquid membrane for Pd(II) separation in the HFSLM system.

This paper reports on the extraction and stripping of Pd(II) from the FPCB wastewater as the feed solution via HFSLM. Several parameters influencing the extraction and stripping efficiency of Pd(II) were investigated: types of diluents, extractants, and stripping agents, concentrations of extractants and stripping agents, pH of the feed solution, initial concentration of Pd(II), operating temperature, flow rates of feed and stripping solutions, operating time, and stability of the liquid membrane. The accuracy of the experimental data in terms of reproducibility of the liquid membrane was reported. Furthermore, the activation energy ( $E_a$ ) was studied in order to determine a rate limiting the Pd(II) separation.

## 2.3 Theory

### 2.3.1 Transport mechanisms of Pd(II) across the liquid membrane phase

The HFSLM system is divided into three main phases: feed, liquid membrane and stripping phases. As shown in **Fig. 2.1**, the mass transport mechanisms involve several steps. Pd(II) in molecule of  $\text{PdCl}_4^{2-}$  dissolving in the feed solution reacts with the organic extractant (LIX 84-I,  $\overline{\text{HL}}$ ) at the feed-liquid membrane interface to form complex species ( $\overline{\text{PdL}_2}$ ). Subsequently,  $\overline{\text{PdL}_2}$  diffuses across the liquid membrane phase to the liquid membrane-stripping interface and then reacts with the stripping agent thiourea ( $\text{NH}_2\text{CSNH}_2$ ) in the stripping solution. As a result, Pd(II) is released into the stripping phase while  $\overline{\text{HL}}$  diffuse back into the feed-liquid membrane interface to react again with Pd(II) in the feed solution. The mass transport of Pd(II) is driven by the concentration gradient between the feed and stripping solutions.



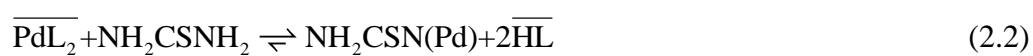
**Fig.2. 1** Mass transport mechanism of Pd(II) across the liquid membrane phase using LIX 84–I as the extractant and the combination of  $\text{NH}_2\text{CSNH}_2$  and  $\text{HCl}$  as the stripping solution.

The extraction reaction of Pd(II) with the extractant ( $\overline{\text{HL}}$ ) is expressed in Eq.

(2.1) [21, 29]:



The stripping reaction of Pd(II) with the stripping agent ( $\text{NH}_2\text{CSNH}_2$ ) is as follows:





### 2.3.2 Thermodynamics

The influence of temperature on the extraction equilibrium ( $K_{ex}$ ) of Pd(II) extracted with LIX 84-I is directly related to the Van't Hoff equation. This equation has a connection with the standard Gibbs free energy and the Gibbs-Helmholtz equation [30]. Gibbs free energy change ( $\Delta G_{ex}^0$ ) for Pd(II) extraction can be calculated by Eqs. (2.3) and (2.4):

$$\Delta G_{ex}^0 = -RT \ln K_{ex} \quad (2.3)$$

$$K_{ex} = -\frac{\Delta G_{ex}^0}{RT} \quad (2.4)$$

However, since activity coefficients have not been incorporated, shifted free energy,  $\Delta G_{ex}^0$ , can be calculated.  $\Delta G_{ex}^0$  is related to the standard enthalpy and extraction entropy changes ( $\Delta H_{ex}^0$  and  $\Delta S_{ex}^0$ ) through the Gibbs-Helmholtz equation. The relationship between Gibbs free energy and the enthalpy and entropy is described by Eq. (2.5):

$$\Delta G^0 = \Delta H_{ex}^0 - T\Delta S_{ex}^0 \quad (2.5)$$

Substituting Eq. (2.5) into Eq. (2.3) results in the Van't Hoff equation in linear form, shown as Eq. (6) [31]:

$$\ln K_{ex} = -\frac{\Delta H_{ex}^0}{RT} + \frac{\Delta S_{ex}^0}{R} \quad (2.6)$$

A plot of  $\ln K_{ex}$  versus  $1/T$  should give a straight line, with the standard enthalpy change calculated from the slope. The equilibrium constant is proportional to  $K_{ex}$ . Thus, slopes of  $\ln K_{ex}$  versus  $1/T$  plots would yield the standard enthalpy change. Previous works discussed the conditions for the constancy of  $\Delta H_{ex}^0$  and  $\Delta S_{ex}^0$ , and these apply here as well [32].

The activation energy values were obtained from the Arrhenius equation, as shown in Eq. (2.7). Activation energy ( $E_a$ ) values have a strong effect on the temperature of actual rate constants.  $E_a$  values are always below 20 kJ/mol. These values are generally accepted as indicative of pure diffusion-limited transport. When the activation energies are higher than 40 kJ/mol, chemical reactions play a role in the transport [33-35]. Between 20 kJ/mol and 42 kJ/mol, a mixed diffusion-chemical reaction mechanism is present [36]. The activation energy of the transport of Pd(II) in the HFSLM system was obtained by plotting the flux ( $J$ ) values versus ( $1/T$ ) [37], using Eq. (2.8):

$$J = Ae^{-E_a/RT} \quad (2.7)$$

$$\ln J = \ln A - \frac{E_a}{R} \frac{1}{T} \quad (2.8)$$

where  $R$  denotes the universal gas constant (8.314 J/mol·K),  $A$  is the frequency factor and  $T$  is the absolute temperature (K).

### 2.3.3 Diluents and liquid membrane stability

The selection of proper extractants and diluents for impregnating the micropores of the hollow fibers is indispensable in order to achieve good extractability and long-term liquid membrane stability. The characteristics of individual diluents are mostly responsible not only for the lifetime of the liquid membrane but also for the solubility of the complex species existing in the liquid membrane phase. Many types of diluents in the HFSLM system have been studied in the literature regarding the different lifetime of the liquid membrane. Fontàs et al. [19] for instance studied the influence of diluents on the separation of Pd(II), Pt(IV) and Rh(III). Various diluents e.g. Cumene, 3-chlorotoluene, anethol, dicyclopentadiene, dodecane, kerosene and decaline were used and mixed with Cyanex 471 as the extractant to be the liquid membrane. The results indicated that 3-chlorotoluene led to the highest permeability values compared with other diluents investigated at a lifetime of the liquid membrane of 2 hrs. Leepipatpiboon et al. [27] investigated the efficiency of seven diluents such as hexane, decanol, chlorobenzene, benzene, dichloromethane, ethylene dichloride and chloroform on the extraction of Co(II) and Ni(II) and on the stability of liquid membrane using Alamine300 as the extractant. The results showed the highest percentage of extraction of Co(II) at 82% under the lifetime of hexane at 200 min. In addition, Sunsandee et al. [28] reported the effect of diluents on the extraction of enantioseparation of (S)-amlodipine using DBTA as the extractant. The diluents i.e. hexane, 1-decanol, chlorobenzene, benzene, 1,2-dichloromethane,

ethylene dichloride, and chloroform were investigated. The percentage of extraction of (S)-amlodipine reaching 77.50% was reported under the longest lifetime of 1-decanol at 150 min. Nonetheless, the literature concerning the influence of hexane, xylene, cyclohexane, benzene, chlorobenzene, 1,2-dichloromethane, dodecane, chloroform and kerosene on the extraction efficiency of Pd(II) together with the stability of the liquid membrane via HFSLM has not been addressed.

### 2.3.4 Percentages of extraction and stripping

The percentage of Pd(II) extraction was defined as:

$$\% \textit{Extraction} = \frac{[M]_{\textit{complex species}}}{[M]_{f, \textit{in}}} \times 100 \quad (2.9)$$

where  $[M]_{\textit{complex species}}$  is the concentration of complex species in the liquid membrane phase, and  $[M]_{f, \textit{in}}$  is the initial Pd(II) concentration in the feed solution.

The percentage of Pd(II) stripping was calculated by:

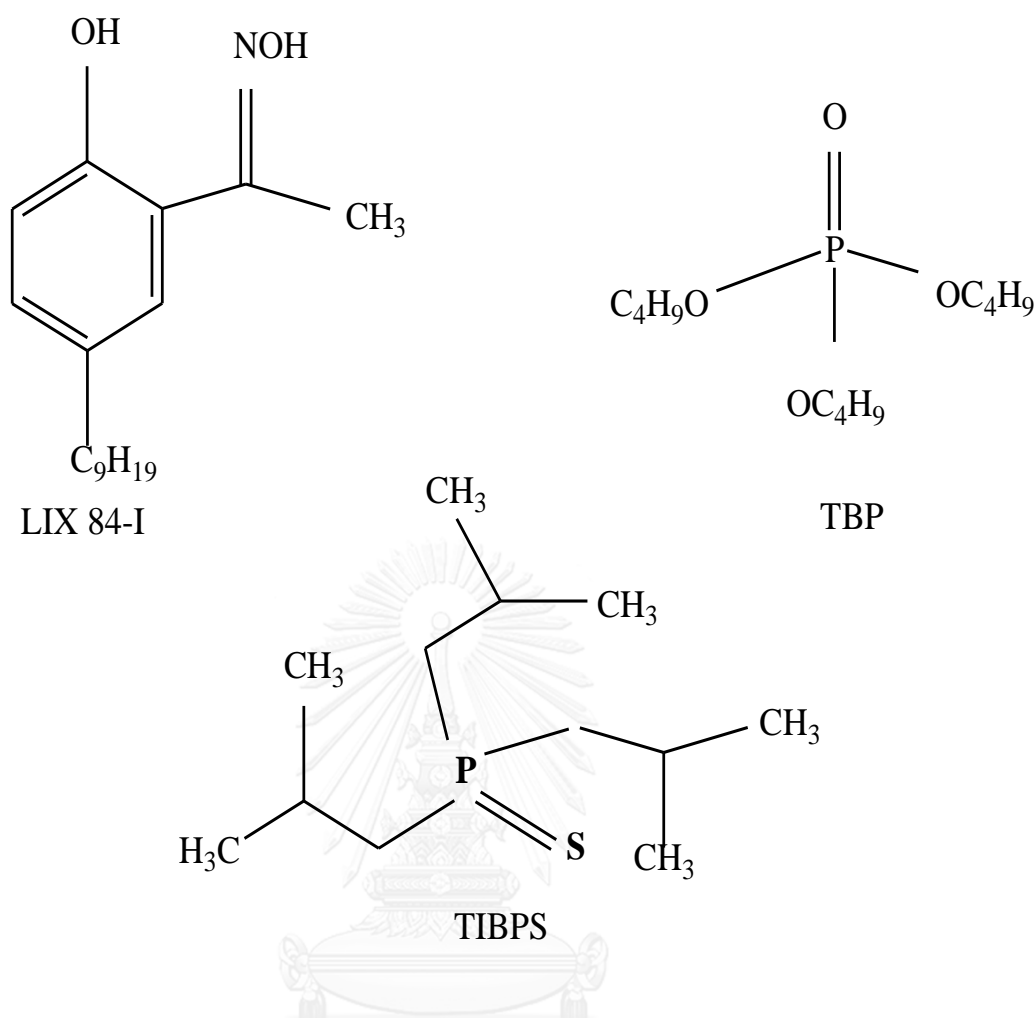
$$\% \textit{Stripping} = \frac{[M]_{s, \textit{out}}}{[M]_{f, \textit{in}}} \times 100 \quad (2.10)$$

where  $[M]_{s, \textit{out}}$  is the outlet concentration of Pd(II) in the stripping solution (mg/L).

## 2.4 Experiment

### 2.4.1 Chemicals and reagents

The wastewater from the FPCB industry containing 100-400 mg/L Pd(II) (supplied by PCTT Ltd., Thailand) was diluted by a hydrochloric acid solution used as the feed solution throughout the experiment. To remove dirt and other unwanted materials, the wastewater was filtered through filter paper (Whatman No. 42). LIX 84-I, used as an extractant, was supplied by Henkel (Thailand) Ltd. Tri-*n*-butyl phosphate (TBP) and triisobutylphosphine sulfide (TIBPS) were supplied by Merck (Germany). The structures of LIX 84-I, TBP and TIBPS are illustrated in **Fig. 2.2**. The stripping agents that were used in this experiment, for example, thiourea ( $\text{NH}_2\text{CSNH}_2$ ) was purchased from RFLC New Zealand, and sulfuric acid ( $\text{H}_2\text{SO}_4$ ), ammonium chloride ( $\text{NH}_4\text{Cl}$ ) and hydrochloric acid (HCl) were purchased from Sigma-Aldrich. Experiments were carried out using several different diluents without further purification. All diluents—benzene, chloroform, chlorobenzene, cyclohexane, 1,2-dichloromethane, dodecane, hexane, kerosene and xylene—were of analytical grade and purchased from Merck. Double-deionized water (Milli-Q; Millipore, USA),  $18.2 \text{ M}\Omega\cdot\text{cm}^{-1}$  conductivity, was used for all dilutions.



**Fig.2. 2** The chemical structures of LIX 84–I, TBP and TIBPS.

#### 2.4.2 Apparatus and analytical instruments

The HFSLM module (Liqui-Cel®Extra-Flow Laboratory) was supplied by CELGARD LLC (Charlotte, NC; formerly Hoechst Celanese). The module uses Celgard microporous polypropylene fibers that are woven into fabric and wrapped around a central tube that supplies the shell side fluid. The properties of the hollow fiber module are specified in **Table 2.1**. A magnetic stirrer (model CMT-V1; Protronics Intertrade Co., Ltd., Thailand) was used to stir the feed and stripping

solutions. The pH values of the feed solution were adjusted by adding periodically a small amount of hydrochloric solution as measured by the professional pH Meter PP-50 (TransInstruments, Singapore). The pump used in all experiments was a peristaltic pump (Cole-Parmer, USA) which can generate pressures up to 8.6 bar (125 psi). The concentration of Pd(II) in the feed and stripping samples was analyzed by the inductively coupled plasma optical emission spectrometer (ICP-OES) (model JY 2000-2; HORIBA Jobin Yvon, France).

**Table 2. 1** Physical characteristics of the hollow fiber module.

Characteristics	Descriptions
Material	polypropylene
Number of fibers	35,000
Fiber inside diameter (cm) $\times 10^2$	2.4
Fiber outside diameter (cm) $\times 10^2$	3.0
Effective length (cm)	19.8
Surface area (cm <sup>2</sup> ) $\times 10^{-4}$	1.4
Area per unit volume (cm <sup>2</sup> cm <sup>-3</sup> )	29.3
Membrane porosity (%)	25
Average pore size (cm) $\times 10^{-5}$	0.3
Membrane tortuosity	2.6
Module diameter (cm)	6.3
Module length (cm)	20.3
Operating temperature (°C)	0-60

### 2.4.3 Procedures

The single hollow fiber module in recirculation mode of feed and stripping solutions was set in the same manner as reported by Wongsawa et al. [38]. At first, the liquid membrane was circulated into the tube and shell sides of the HFSLM for at least 40 min [38] to impregnate in the micropores of the hollow fibers. The excess liquid membrane was completely washed out with distilled water for 10 min. Then, the feed and stripping solution were counter-currently pumped into the tube and shell sides, respectively. Each feed and stripping sample of 30 mL for all investigated influences were kept and analyzed in order to determine the concentration of Pd(II).

## 2.5 Results and discussion

### 2.5.1 Influences of types of diluents

Nine diluents i.e. hexane, xylene, cyclohexane, benzene, chlorobenzene, 1,2-dichloromethane, dodecane, chloroform and kerosene were investigated using LIX84-I as the extractant and a mixture of  $\text{NH}_2\text{CSNH}_2$  with HCl as the stripping solution. The percentages of Pd(II) extraction and stripping are listed in **Table 2.2**. The polarity index values of diluents as reported elsewhere [27, 28, 39] were also considered in order to select the appropriate diluents.



**Table 2. 2** Performance of the diluents on the percentages of Pd(II) extraction and stripping.

Diluents	Polarity index (-)	% Extraction	% Stripping
Hexane	0.1[27]	66.25 ± 1.60	59.80 ± 1.41
Cyclohexane	0.2[28]	67.13 ± 1.43	63.96 ± 1.45
Chlorobenzene	2.5[27]	68.68 ± 6.90	64.35 ± 4.43
Benzene	2.7[27]	71.89 ± 3.65	63.01 ± 2.95
1,2-dichloromethane	3.1[28]	73.20 ± 1.44	55.36 ± 2.97
Chloroform	4.1[39]	64.13 ± 1.42	61.33 ± 1.10
Dodecane	n/a	58.31 ± 0.80	58.30 ± 1.34
Kerosene	n/a	70.98 ± 1.41	67.75 ± 4.34
Xylene	n/a	67.68 ± 0.74	63.76 ± 1.47

**Note:** The percentages of Pd(II) extraction and stripping were studied under pH 2 of the feed solution, the Pd(II) concentration in the feed solution of 100 mg/L, the LIX84-I concentration of 2% (v/v), the stripping concentration of 0.1 M  $\text{NH}_2\text{CSNH}_2$  mixed with 1 M HCl and 100 mL/min of feed and stripping flow rates.

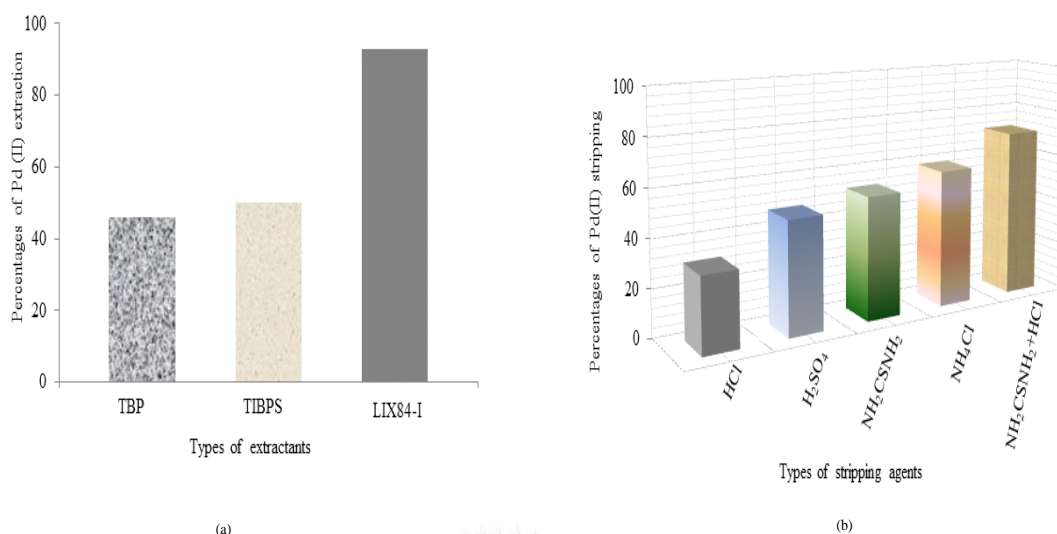
The results in Table 2 indicated that 1,2-dichloromethane provided the higher percentage of extraction of Pd(II) at 73.20%, with a relative error of approximately 1.5% when compared with other diluents with difference polarity indexes (hexane, cyclohexane, chlorobenzene, benzene and chloroform). On the other hand, the percentage of Pd(II) stripping in the case of 1,2-dichloromethane was observed to be a moderate 55.36%, with a relative error of approximately 3%. This tendency might be related to the polarity and interaction of different organic diluents with the extractant [27]. In the case of the three diluents without polarity indexes (dodecane, kerosene and xylene), the results indicated that kerosene showed the best performance

and achieved more than 70% extraction of Pd(II), and about 67% for stripping, with relative errors of approximately 1.4% and 4.3%, respectively. In this study, however, kerosene was selected for further experiments. This is because kerosene has balanced percentages of Pd(II) extraction and stripping, including a high flash point for hydrocarbon diluents [22]. In addition, kerosene is most readily available and the least expensive of the diluents. Similar results were presented in a previous report by Reddy et al. [22] which highlighted that kerosene is a suitable diluent for Pd(II) extraction employing 14%(v/v) LIX 84–I as the extractant. The percentages of Pd(II) extraction reaching almost 100% were obtained. Panigrahi et al. [40] was also successful in using LIX 84–I dissolved in kerosene for the extraction and stripping of Cu(II).

### 2.5.2 Influences of types of extractants and stripping agents

From a review of literature, LIX 84–I [21], TIBPS [19] and TBP [25] showed high performance in the extraction of Pd(II). Consequently, these extractants were selected to investigate the extraction of Pd(II) in chloride media. The results as shown in **Fig. 2.3(a)** indicated that TBP performed poorly in extracting Pd(II) from aqueous feed solution. This is because TBP can react with both anions and cations in the aqueous feed solution. TIBPS is a neutral extractant, classified as a soft base, which can react with anions and cations in the solution (similar to TBP). Thus, percentage of Pd(II) extraction was low. LIX 84–I was found to be the most suitable extractant for the extraction of Pd(II). This corresponded to the fact that LIX 84–I is an acidic extractant which reacts well with cationic form of Pd(II). Similar results demonstrated

the influence of LIX 84–I on the extraction and stripping of Pd(II) and Pt(IV) from hydrochloric solutions using the solvent extraction method, as reported by Rane and Venugopal [21]. The latter reported that Pd(II) was selectively extracted from  $\text{PdCl}_4^{2-}$  in the aqueous feed solution by LIX84–I. Extraction of Pd(II) reached more than 97% while chloride ions were released in the aqueous feed solution as shown in Eq. (1). Foulon et al. [29, 41] studied the effect of LIX63 which is an acidic extractant on the extraction of Pd(II) from  $\text{PdCl}_4^{2-}$ . The results demonstrated that LIX63 can selectively extract Pd(II) and then releases chloride ions into the aqueous feed solution. The studies of Rane and Venugopal [21] and Foulon et al. [29, 41] can confirm that the LIX group is more effective for the extraction of Pd(II). Furthermore, LIX84–I was successfully used in the extraction of the other metal ions i.e. Cu(II) as reported by Pancharoen et al. [42]. In this work, LIX 84–I was therefore recommended for use throughout the experiments for extraction of Pd(II) from the aqueous feed solution.



**Fig.2. 3** Percentages of extraction and stripping of Pd(II) against (a) types of extractants and (b) types of stripping agents under conditions: feed solution at pH 2, 2% (v/v) LIX 84–I, the combination of 1 M NH<sub>2</sub>CSNH<sub>2</sub> and 1 M HCl, 100 mg/L Pd(II) in the feed solution and equal flow rates of feed and stripping solutions of 100 mL/min.

For the stripping of Pd(II) from complex species, a number of stripping agents were used. Certainly, the fundamental principle depends on the characteristics of the selected extractants [43]. In this work, the investigation of stripping agents which have an influence on the stripping of Pd(II) from the liquid membrane phase was carried out by testing stripping agents which were able to form complex species with Pd(II) strong enough to strip Pd(II) from the complex species. The stripping agents—H<sub>2</sub>SO<sub>4</sub>, HCl, NH<sub>2</sub>CSNH<sub>2</sub>, NH<sub>4</sub>Cl, and a combination of NH<sub>2</sub>CSNH<sub>2</sub> and HCl—were chosen because of their good Pd(II) stripping efficiency, as noted in previous reports [21, 44]. The percentage of stripping by different stripping agents at identical concentrations of 0.1 M is illustrated in **Fig. 2.3(b)**. The results indicated that the

stripping efficiency of Pd(II) decreased in the order of  $\text{NH}_2\text{CSNH}_2 + \text{HCl} > \text{NH}_4\text{Cl} > \text{NH}_2\text{CSNH}_2 > \text{HCl} > \text{H}_2\text{SO}_4$ . The combination of  $\text{NH}_2\text{CSNH}_2$  and HCl achieved a stripping percentage of approximately 70%. This can be attributed to the fact that  $\text{NH}_2\text{CSNH}_2$  mixed with HCl has stronger decomplexation ability for Pd(II) compared with other reagents. These results are consistent with extraction of Pd(II) employing Alamine 336 as the extractant, and using a mixture of  $\text{NH}_2\text{CSNH}_2$  and HCl as the stripping agent as reported by Sun and Lee [45]. In addition, Reddy et al. [22] also used a mixture of  $\text{NH}_2\text{CSNH}_2$  and HCl for stripping the complex species in the organic solvent; the results were higher than 99.7% for both metal ions. Thus, the mixture of  $\text{NH}_2\text{CSNH}_2$  and HCl was selected as the stripping solution for further study of other relevant variables.

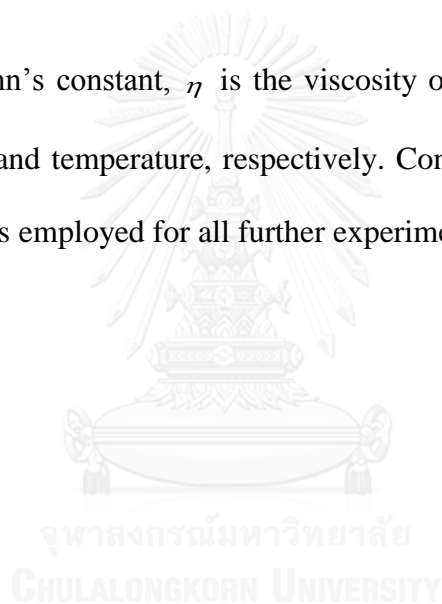
### 2.5.3 Influences of concentrations of extractant and stripping agent

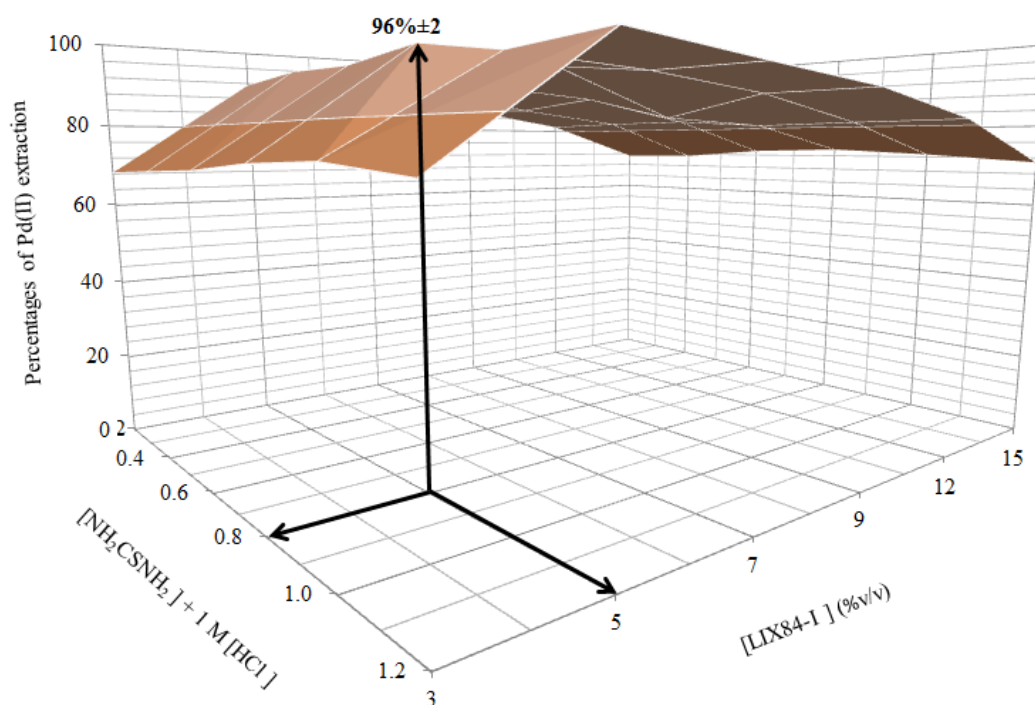
Extraction efficiency of metal ions through HFSLM relies on the concentration of extractant molecules in the liquid membrane phase [19, 46]. In this work, the influence of LIX84-I concentration in the liquid membrane phase on the efficiency of Pd(II) extraction was investigated by varying the concentration of LIX84-I in a range of 2–15% (v/v) and the concentration of  $\text{NH}_2\text{CSNH}_2$  of 0.2–1.2 M mixed with the fixed concentration of 1 M HCl as the stripping solution. The results in **Fig. 2.4** indicated that the extraction of Pd(II) reaching almost 96% was achieved at 5% (v/v) LIX84-I. The percentage of extraction increased as the concentration of LIX84-I increased. However, extraction percentage of Pd(II) decreased at concentrations > 9% (v/v) due to an increase in liquid membrane viscosity. This resulted in mass transfer

obstruction in the liquid membrane phase, as described in a previous report [47]. This viscosity phenomenon can be explained by the molecular kinetic equation of Nernst; the diffusion coefficient  $\xi$  can be expressed as cited in many previous publications [48, 49]:

$$\xi = \frac{k_B T}{6\pi\eta r} \quad (2.11)$$

where  $k_B$  is Boltzmann's constant,  $\eta$  is the viscosity of the liquid membrane, and  $r$  and  $T$  are the radius and temperature, respectively. Consequently, a concentration of 5% (v/v) LIX84–I was employed for all further experiments.

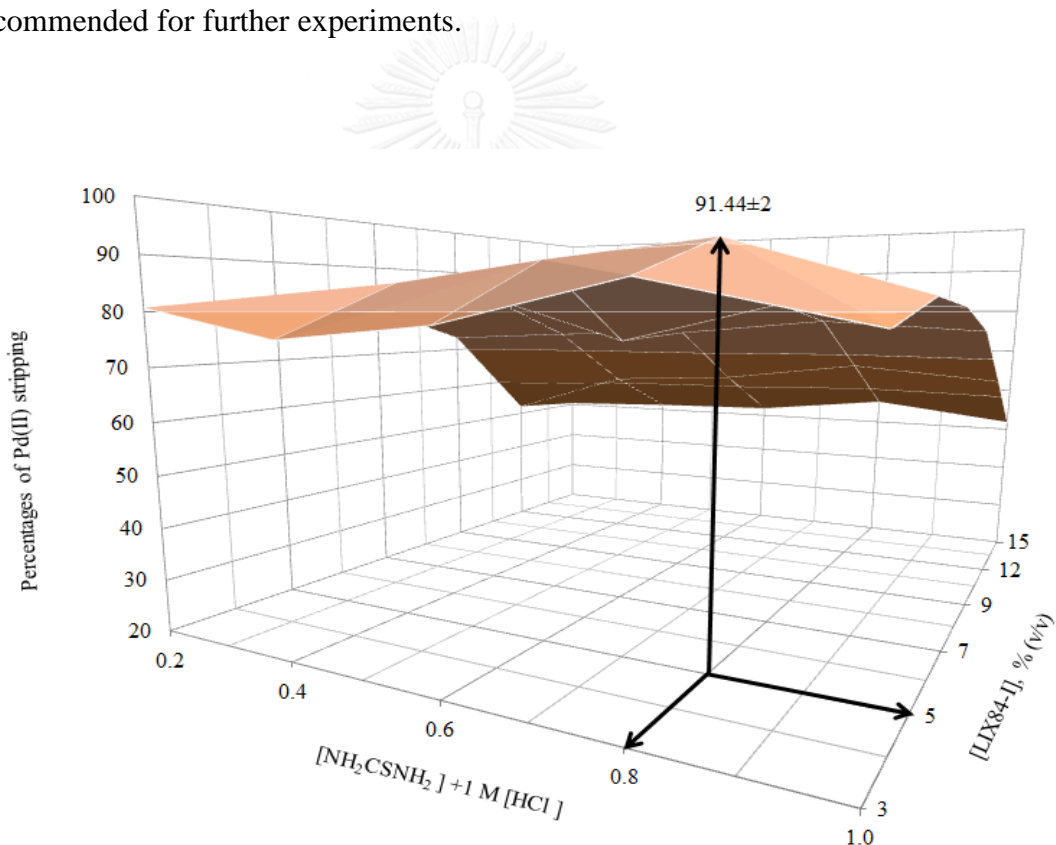




**Fig.2. 4** Percentages of extraction of Pd(II) against concentrations of LIX 84–I and concentrations of NH<sub>2</sub>CSNH<sub>2</sub> mixed with 1 M HCl under conditions: feed solution at pH 2, 100 mg/L Pd(II) in the feed solution, and equal flow rates of feed and stripping solutions at 100 mL/min.

Moreover, in order to investigate the significance of the role of stripping concentration in the stripping of Pd(II) from the membrane phase, various concentrations of NH<sub>2</sub>CSNH<sub>2</sub> (0.2–1.2 M) were used with a fixed concentration of 1 M HCl. The results showed that stripping percentage of Pd(II) of more than 90% was achieved at 0.8 M NH<sub>2</sub>CSNH<sub>2</sub> as presented in **Fig. 2.5**. When the concentration of NH<sub>2</sub>CSNH<sub>2</sub> was higher than 0.8 M, stripping percentage of Pd(II) decreased because of the precipitation of NH<sub>2</sub>CSNH<sub>2</sub>. This led to difficulty in stripping the

complex species at the liquid membrane–stripping interface. Indeed, this precipitation blocked the pores between the liquid membrane and the stripping interface. The results were in accordance with a previous publication as reported by Pirom et al.[50]. The latter highlighted the influence of the concentration of stripping agents on the extraction and stripping of Co(II) and Mn(II). The results also showed that a lower  $\text{NH}_2\text{CSNH}_2$  concentration in the stripping phase is favorable and sufficient for Pd(II) stripping. Therefore, a concentration of 0.8 M  $\text{NH}_2\text{CSNH}_2$  and 1 M HCl was recommended for further experiments.



**Fig.2. 5** Percentages of stripping of Pd(II) against concentrations of LIX 84–I and concentrations of  $\text{NH}_2\text{CSNH}_2$  mixed with 1 M HCl under conditions: feed solution at pH 2, 100 mg/L Pd(II) in the feed solution, and equal flow rates of feed and stripping solutions at 100 mL/min.

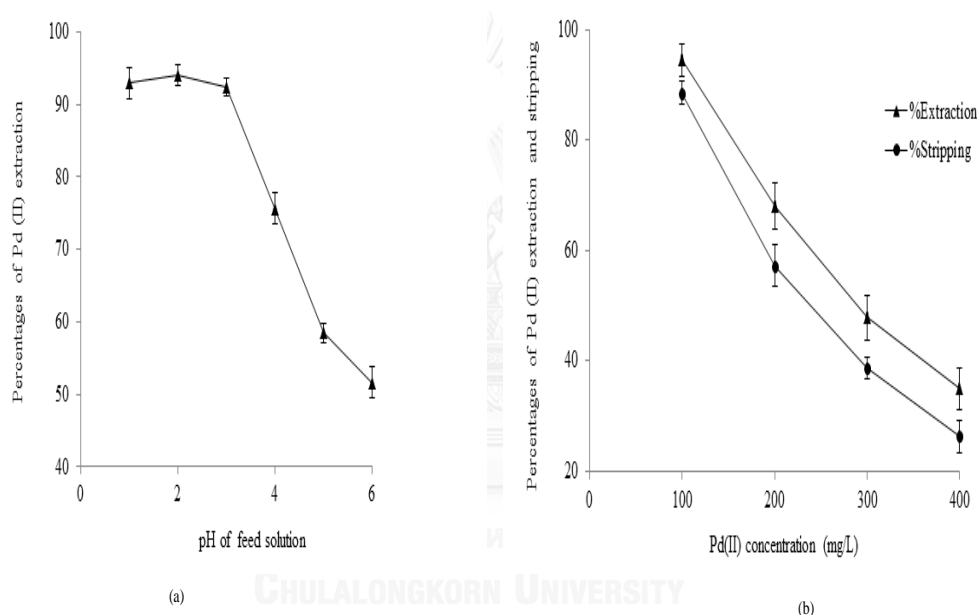


#### 2.5.4 Influences of pH and Pd(II) concentration in feed solution

In the literature, it has been reported that the efficiency of LIX84-I for metal ion extraction from acidic aqueous solutions depended on the pH of feed solution [38]. In this study, the pH of feed solution was investigated in a range of 1–6 M. The relationship between extraction efficiency and initial aqueous pH is illustrated in **Fig. 2.6(a)**. The results indicate that percentage of extraction increased when the pH of feed solution increased. Maximum extraction percentage was achieved at pH 2. However, it subsequently decreased. A similar phenomenon was noted in a previous report [21] which highlighted that extraction efficiency of Pd(II) in chloride solutions with LIX84-I increased when the initial aqueous pH increased, reaching a maximum at pH 3 and then decreased. In this work, the optimum value of pH for the feed solution proved to be pH 2 where a high extraction percentage of Pd(II) is achievable. Thus, the pH value of the feed solution at 2 was selected for further studies.

The effect of the initial Pd(II) concentration in the feed solution on the extraction efficiency of Pd(II) was investigated in a range of 100–400 mg/L. The experimental results showed that the concentration of Pd(II) in the membrane increased when the initial Pd(II) concentration was 100 mg/L, as demonstrated in **Fig. 2.6(b)**. The percentages of Pd(II) extraction decreased at concentrations of Pd(II) higher than 100 mg/L. The decrease in extraction efficiency at higher concentrations of Pd(II) may be because of the increasing overall mass transfer resistance with higher Pd(II) concentration, as reported previously [51]. It is also noteworthy that a decrease in distribution ratio was observed as initial Pd(II) concentration increased. From the

experiments, it can be concluded that the HFSLM system is suitable for the extraction of Pd(II) at very low concentration, in particular lower than 100 mg/L. In the case of Pd(II) extraction at high concentration ( $> 100$  mg/L), solvent extraction proved to be a suitable system corresponding to the work of Rane and Venugopal [21] and Reddy et al. [22]. Therefore, the concentration of 100 mg/L Pd(II) was used in further experiments.



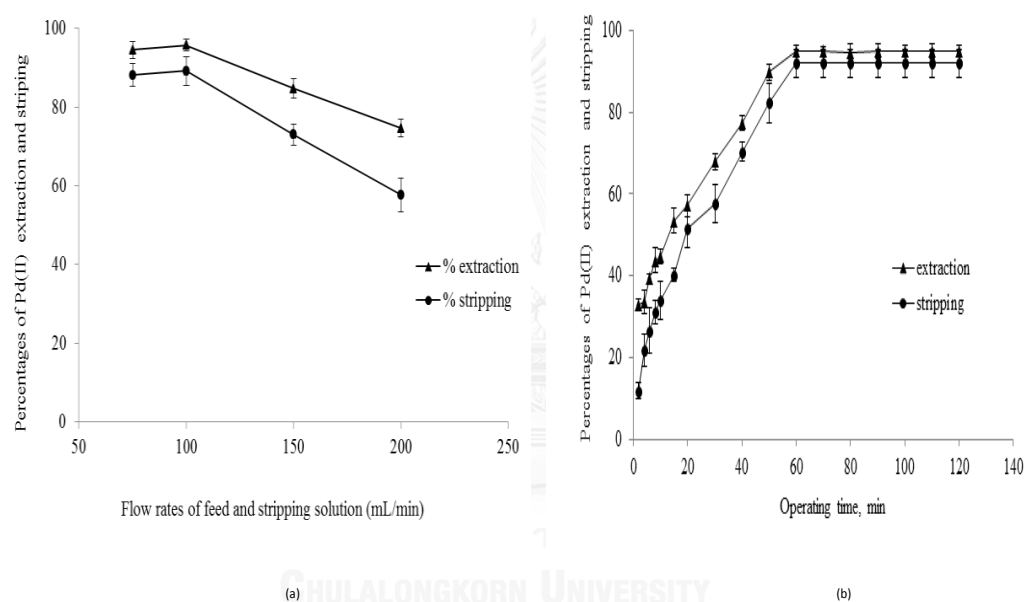
**Fig.2. 6** Percentages of extraction and stripping of Pd(II) against (a) pH of feed solution and (b) initial concentration of Pd(II) in feed solution under conditions: 5% (v/v) LIX 84-I, the combination of 0.8 M  $\text{NH}_2\text{CSNH}_2$  and 1 M HCl and equal flow rates of feed and stripping solutions of 100 mL/min.

### 2.5.5 Influences of hydrodynamics and operating time

The flow rate of feed and stripping solution may control the mechanism of Pd(II) transport across HFSLM incorporating several mass transfer resistances and may govern extractability. Consequently, the influence of feed and stripping flow rate was evaluated and results are illustrated in **Fig. 2.7(a)**. Equal flow rates of feed and stripping solutions were varied from 75 to 200 mL/min. This demonstrated that percentages of extraction and stripping increased when both flow rates increased from 75 to 100 mL/min. At 75 mL/min, extraction efficiency was lower than at 100 mL/min because of the difficulty in supplementing Pd(II) in the hollow fiber module, thus possibly depleting the liquid membrane and resulting in a reduction in the extractability of Pd(II). When the flow rate was increased up to 100 mL/min, the boundary layers between the feed–liquid membrane and liquid membrane–stripping interfaces were thin, causing a decrease in the mass transfer resistance and thus improving the extraction and stripping reactions. However, at higher flow rates, extraction efficiency tended to drop which may result in the loss of extractants and diluents from the liquid membrane phase. Similar results demonstrated the influence of high flow rates of feed and stripping solutions on the extraction and stripping of uranium as reported by Lothongkum et al.[52]. In addition, Wongsawa et al. [38] reported that the operation of the HFSLM system at high flow rates in both feed and stripping was not recommended. Therefore, an equal operating flow rate for both feed and stripping solutions of 100 mL/min was recommended for further experiments.

The extraction and stripping of Pd(II) from chloride solution were determined for different operating times. The percentages of Pd(II) extraction and stripping

increased when the operating times increased up to 60 min, as shown in **Fig. 2.7(b)**. Further increases in operating time showed stable behavior, with percentages of approximately 95% for extraction and 90% for stripping. This indicated that the equilibrium time for this system was 60 min.



**Fig.2. 7** Percentages of extraction and stripping of Pd(II) against (a) flow rates of feed and stripping solutions and (b) operating time under conditions: feed solution at pH 2, 100 mg/L Pd(II) in the feed solution, 5% (v/v) LIX 84–I, the combination of 0.8 M  $\text{NH}_2\text{CSNH}_2$  and 1 M HCl and equal flow rates of feed and stripping solutions at 100 mL/min.

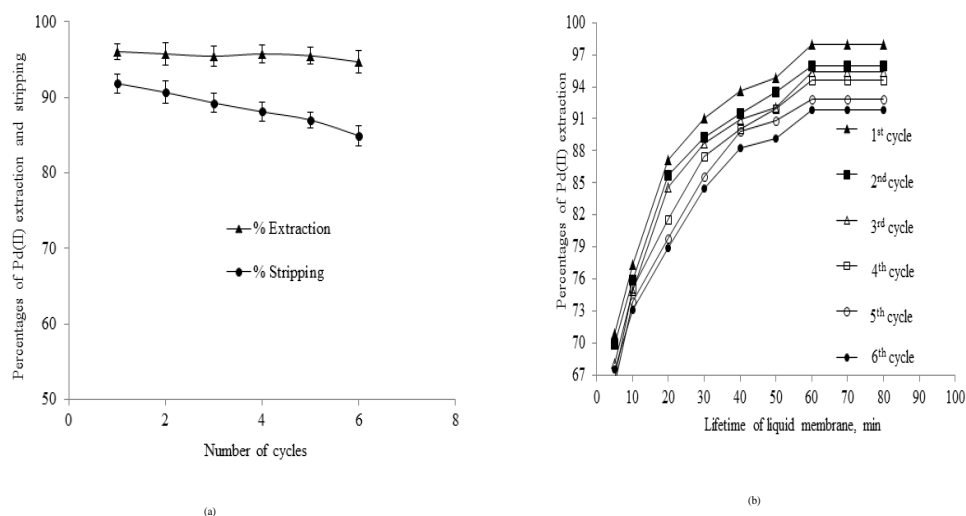
### 2.5.6 Influences of operating temperature

Temperature has an important influence on the extraction process because it affects both the extraction time and extraction efficiency. Increasing the temperature in the feed solution increases the diffusion coefficients of the target ions and also decreases the viscosity of the liquid membrane phase. Therefore, the influence of temperature on the efficiency of Pd(II) extraction was investigated in the range of 30–50 °C. The results indicated that an increase in temperature resulted in a straight increase in extraction percentage as confirmed by the  $R^2$  value of 0.965. Thus, it was noted that the percentages of extraction increased from 96% at 30 °C to approximately 98% at 50 °C. However, HFSLM has a restricted operating temperature, which cannot exceed 60 °C, as shown in **Table 2.1**. This small increase in extraction efficiency was achieved since the increase in temperature caused a positive complexation reaction of Pd(II) in the liquid membrane phase, a reaction which involves proton transfer or hydrogen bond formation. The calculated results of enthalpy changes by correlation with the Van't Hoff equation showed negative values, indicating that the extraction reaction of Pd(II) at the feed–liquid membrane interface is an exothermic reaction. Thus, complex species increased in accordance with increasing temperature. Furthermore, at higher temperatures, a decrease in the viscosity of extractants and diluents in the membrane phase improves the permeability between the feed and membrane interface, facilitating the diffusion of complex species through the liquid membrane phase. This is another reason for the increased efficiency of Pd(II) extraction. Additionally, the activation energy ( $E_a$ ) values can be determined using the

Arrhenius equation. These values have a strong effect on the reaction rate constants. It was found that extraction rate increased when temperature was increased, and the apparent activation energy,  $E_a = 30$  kJ/mol, was calculated from Eq. (8) for the extraction. The data obtained in the present system indicates that the extraction rate for Pd(II) may be controlled by a mixed regime (both kinetic and diffusion) [33-35].

### 2.5.7 Influences of separation cycles through the hollow fiber module

HFSLM methods have been shown to be extremely successful for the simultaneous extraction and stripping of target ions from wastewater [46]. One of the concerns about the continuous use of HFSLM for extraction and stripping of Pd(II) is the stability of the fiber material. In addition, the long-term stability of the HFSLM system is important for scaling-up decisions in actual industrial applications. Thus, the stability of the liquid membrane was investigated by using the separation cycle at optimum conditions: feed solution at pH 2, 5% (v/v) LIX84-I concentration dissolved in kerosene, a combination of 0.8 M  $\text{NH}_2\text{CSNH}_2$  and 1 M HCl, equal flow rates of feed and stripping solutions of 100 mL/min, and an operating time of 60 min. **Fig. 2.8(a)** and **Fig. 2.8(b)** illustrate the percentages of extraction and stripping of Pd(II) versus the operation of each cycle and lifetime of the liquid membrane. As can be seen, there is a slight decrease in the percentage of extraction during the course of six consecutive cycles. This decrease in extraction and stripping efficiency is due to the loss of extractants and diluents from the liquid membrane phase [53].



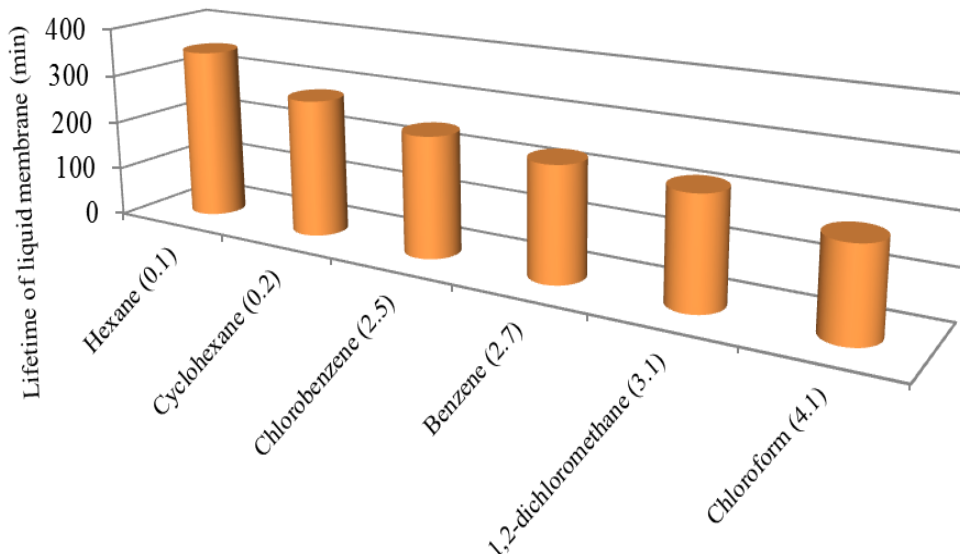
**Fig. 2. 8** Percentages of extraction and stripping of Pd(II) against (a) number of separation cycles through a single-HFSLM module and (b) lifetime time of liquid membrane for any separation cycles through a single-HFSLM module under conditions: feed solution at pH 2, 100 mg/L Pd(II) in the feed solution, 5% (v/v) LIX 84–I, the combination of 0.8 M  $\text{NH}_2\text{CSNH}_2$  and 1 M HCl and equal flow rates of feed and stripping solutions at 100 mL/min.

For the investigation of extraction and stripping of Pd(II), the accuracy of the data is a function of reproducibility under identical optimum operating conditions in order to verify the feasibility and consistency of the experimental results. In this context, six different extraction operations were conducted independently; the reproducibility of the results was subsequently checked. As illustrated in **Fig. 2.8(a)**, the extraction efficiency has a marginal variation, indicating excellent reproducibility of the experimental data. The highest percentage of Pd(II) extraction reaching 97% with a standard deviation of 1.3% was observed.

### 2.5.8 Influences of diluents on membrane stability

Several parameters must be considered in selecting the organic diluents to be immobilized in the micropores as a liquid membrane. The selection of proper diluents is significant because of instability of the liquid membrane. Parameters such as viscosity, water solubility, high boiling point etc. were used to achieve the most suitable selection of diluents for sufficient long-term stability of the liquid membrane in the extraction and stripping of Pd(II) under optimum conditions. In this study, one of the significant highlights is the influence of the polarity indexes of individual diluents on the stability of the liquid membrane, together with their effect on extraction and stripping efficiency. First of all, loss or leakages of the liquid membrane by adding Sn(IV) to the feed solution using the optimum conditions need to be checked. The results demonstrated that Sn(IV) can be used as a tracer to investigate membrane stability because Sn(IV) was not extracted under optimum conditions existing in the aqueous feed solution. Therefore, if Sn(IV) was detected in the stripping solution, this would indicate that the liquid membrane had been damaged and had leaked into the feed and stripping solution.

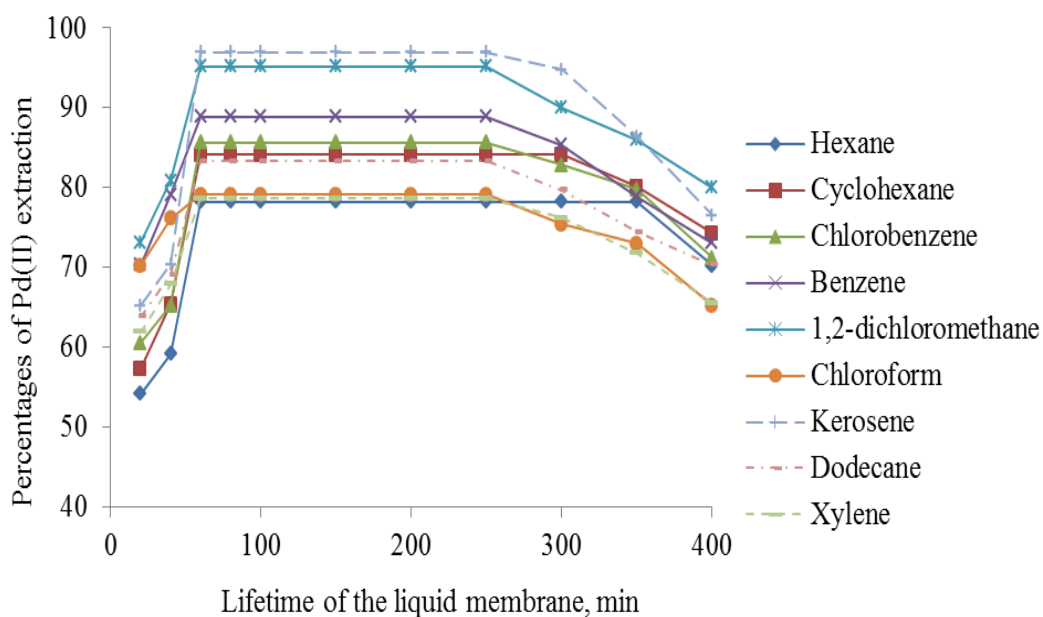




**Fig.2. 9** Lifetime of the liquid membrane studied by the HFSLM system against types of diluents with their polarity indexes under conditions: feed solution at pH 2, 100 mg/L Pd(II) in the feed solution, 5% (v/v) LIX 84-I, the combination of 0.8 M  $\text{NH}_2\text{CSNH}_2$  and 1 M HCl and equal flow rates of feed and stripping solutions at 100 mL/min.

The influence of diluents with different polarity indexes together with non-polarity indexes on the stability of the liquid membrane was investigated. The results demonstrated the stability of the liquid membrane for individual diluents in the order of hexane (0.1) > cyclohexane (0.2) > chlorobenzene (2.5) > benzene (2.7) > 1,2-dichloromethane (3.1) > chloroform (4.1), as shown in **Fig. 2.9**. As the polarity of individual diluents decreases, the stability of the liquid membrane increases. This is similar to the work of Leepipatpiboon et al [27]. When diluents with high polarity indexes are close to the polarity index of water (9.0), the stability of the liquid membrane decreases because of greater solubility of diluents in the aqueous feed and

stripping phases. This is because the polar molecules of diluents interact more strongly with the polar molecules of water. In other words, if the investigated diluents have close polarity indexes with water, the liquid membrane leaks out from the pores of the hollow fibers. Moreover, the higher the increase of polarity index of diluents results in the interface layers ( $\delta$ ) growing too thick. Accordingly, the liquid membrane leaks out from the micropores of the hollow fibers to the feed and the stripping solutions. For this reason, diluents with higher polarity indexes lead to higher extraction performance of the target ions but lower stability. In **Fig. 2.10**, the results indicated that the lifetime of liquid membrane for about 250 min was achieved using kerosene, dodecane and xylene as the diluents. Although kerosene is without a polarity index, the lifetime of the liquid membrane is somewhat low, compared with diluents with polarity indexes. This is because the solubility of kerosene in LIX84-I is lower than diluents with polarity indexes. Therefore, the selection of diluents with polarity indexes dissolved in LIX84-I impregnated in the liquid membrane results in the longest stability of 350 min (hexane), demonstrating that the polarity index is a single-parameter correlation. Hence, with decreasing polarity of the diluents, the stability of the liquid membrane is increased. However, in this study, kerosene was employed throughout which attributed to the balance of percentages of Pd(II) extraction and stripping.



**Fig.2. 10** Percentages of extraction of Pd(II) studied by the HFSLM system against lifetime of individual diluents under conditions: feed solution at pH 2, 100 mg/L Pd(II) in the feed solution, 5% (v/v) LIX 84–I, the combination of 0.8 M  $\text{NH}_2\text{CSNH}_2$  and 1 M HCl and equal flow rates of feed and stripping solutions at 100 mL/min.

## 2.6 Conclusion

This work investigated the simultaneous extraction and stripping of Pd(II) from FPCB wastewater via HFSLM. The highest percentages of Pd(II) extraction and stripping (96% and 91%, respectively) were obtained with feed solution at pH 2, 5% (v/v) LIX84–I dissolved in kerosene as liquid membrane, 0.8 M  $\text{NH}_2\text{CSNH}_2$  mixed with 1 M HCl as the stripping agent, and equal flow rates of feed and stripping solutions of 100 mL/min. Diluents with lower polarity indexes could prolong membrane stability; however the percentages of extraction and stripping decreased. By using hexane, with a polarity index of 0.1, the longest stability of the liquid

membrane (350 min) was achieved. The operating temperature in a range of investigation (30–50 °C) had a slight effect on the separation of Pd(II). The extraction reaction of LIX84–I with Pd(II) were controlled by a mixed regime (both kinetic and diffusion) due to activation energy,  $E_a = 30$  kJ/mol. Reproducibility of the liquid membrane was found to be excellent in the recycling mode. The HFSLM system was able to successfully extract and strip Pd(II) from the FPCB wastewater.

## 2.7 Acknowledgements

The authors gratefully acknowledge financial support from the Thailand Research Fund through the Royal Golden Jubilee Ph.D. Program (Grant No. PHD/0297/2550). Many thanks also to the Separation Laboratory, Department of Chemical Engineering, Chulalongkorn University, Bangkok.

## 2.8 References

- [1] D. Afzali, R. Jamshidi, S. Ghaseminezhad, Z. Afzali, *Arabian J. Chem.*, 5 (2012) 461-466.
- [2] A. Uheida, Y. Zhang, M. Muhammed, *J. Membr. Sci.*, 241 (2004) 289-295.
- [3] T. Gebel, H. Lantzsch, K. Pleßow, H. Dunkelberg, *Res-Gen. Tox. En.*, 389 (1997) 183-190.

- [4] A. Dakshinamoorthy, P.S. Dhimi, P.W. Naik, N.L. Dudwadkar, S.K. Munshi, P.K. Dey, V. Venugopal, *Desalination*, 232 (2008) 26-36.
- [5] I.M. Ahmed, A.A. Nayl, J.A. Daoud, *Int. J. Miner. Process.*, 101 (2011) 89-93.
- [6] Z. Hubicki, M. Leszczyńska, B. Łodyga, A. Łodyga, *Miner. Eng.*, 19 (2006) 1341-1347.
- [7] B. Godlewska-Żyłkiewicz, *Spectrochim. Acta., Part B*, 58 (2003) 1531-1540.
- [8] H. Ebrahimzadeh, N. Tavassoli, M.M. Amini, Y. Fazaeli, H. Abedi, *Talanta*, 81 (2010) 1183-1188.
- [9] B. Gupta, I. Singh, *Hydrometallurgy*, 134 (2013) 11-18.
- [10] B. Swain, J. Jeong, S.-k. Kim, J.-c. Lee, *Hydrometallurgy*, 104 (2010) 1-7.
- [11] C. Fontas, C. Palet, V. Salvado, M. Hidalgo, *J. Membr. Sci.*, 178 (2000) 131-139.
- [12] F.F. Zha, A.G. Fane, C.J.D. Fell, *J. Membr. Sci.*, 107 (1995) 59-74.
- [13] I. Akin, S. Erdemir, M. Yilmaz, M. Ersoz, *J. Hazard Mater.*, 223 (2012) 24-30.
- [14] C. Naksang, N. Sunsandee, N. Thamphiphit, U. Pancharoen, P. Ramakul, N. Leepipatpiboon, *Separ. Sci. Technol.*, 48 (2013) 867-876.
- [15] S. Suren, T. Wongsawa, U. Pancharoen, T. Prapasawat, A.W. Lothongkum, *Chem. Eng. J.*, 191 (2012) 503-511.
- [16] J.W. Choi, K.S. Cho, B.K. Oh, Y.K. Kim, I.J. Youn, W.H. Lee, *J. Ind. Eng. Chem.*, 9 (2003) 294-300.

- [17] J.W. Choi, K.S. Cho, B.K. Oh, I.J. Youn, J. Jeong, S. Park, W.H. Lee, *J. Ind. Eng. Chem.*, 7 (2001) 230-240.
- [18] P. Ramakul, U. Mooncluen, Y. Yanachawakul, N. Leepipatpiboon, *J. Ind. Eng. Chem.*, 18 (2012) 1606-1611.
- [19] C. Fontas, V. Salvado, M. Hidalgo, *J. Membr. Sci.*, 223 (2003) 39-48.
- [20] K. Wieszczycka, M. Kaczerewska, M. Krupa, A. Parus, A. Olszanowski, *Sep. Purif. Technol.*, 95 (2012) 157-164.
- [21] M.V. Rane, V. Venugopal, *Hydrometallurgy*, 84 (2006) 54-59.
- [22] B.R. Reddy, B. Raju, J.Y. Lee, H.K. Park, *J. Hazard Mater.*, 180 (2010) 253-258.
- [23] R. Singh, A.R. Khwaja, B. Gupta, S.N. Tandon, *Talanta*, 48 (1999) 527-535.
- [24] C. Fontas, V. Salvado, M. Hidalgo, *Ind. Eng. Chem. Res.*, 41 (2002) 1616-1620.
- [25] J.Y. Lee, B. Raju, B.N. Kumar, J.R. Kumar, H.K. Park, B.R. Reddy, *Sep. Purif. Technol.*, 73 (2010) 213-218.
- [26] Y. Liu, B. Shi, *Sep. Purif. Technol.*, 65 (2009) 233-242.
- [27] N. Leepipatpiboon, U. Pancharoen, P. Ramakul, *Korean J. Chem. Eng.*, 30 (2013) 194-200.
- [28] N. Sunsandee, P. Ramakul, U. Pancharoen, N. Leepipatpiboon, *Sep. Purif. Technol.*, 116 (2013) 405-414.
- [29] C. Foulon, D. Pareau, G. Durand, *Hydrometallurgy*, 51 (1999) 139-153.
- [30] F. Angulo-Brown, L.A. Arias-Hernández, *J. Phys. Chem.*, 100 (1996) 9193-9195.

- [31] S.V. Yadav, V.V. Mahajani, *Separ. Sci. Technol.*, 42 (2007) 1283-1303.
- [32] E.O. Otu, *Thermochim. Acta.*, 329 (1999) 117-121.
- [33] P.A. O'Hara, M.P. Bohrer, *J. Membr. Sci.*, 44 (1989) 273-287.
- [34] J.M. Zhao, W. Li, D.Q. Li, Y. Xiong, *Solvent Extr. Ion Exc.*, 24 (2006) 165-176.
- [35] R. Davarkhah, F. Khanramaki, M. Asgari, B. Salimi, P. Ashtari, M. Shamsipur, *J. Radioanal Nucl. Ch.*, (2013) 1-8.
- [36] W. Liao, G. Yu, S. Yue, D. Li, *Talanta*, 56 (2002) 613-618.
- [37] P. Peng, A.G. Fane, X. Li, *Desalination*, 173 (2005) 45-54.
- [38] T. Wongsawa, N. Leepipatpiboon, N. Thamphiphit, U. Pancharoen, A.W. Lothongkum, *Chem. Eng. J.*, 222 (2013) 361-373.
- [39] Polarity index -<http://macro.lsu.edu/howto/solvents/Polarity%20index.htm>, (accessed 02.02.2014).
- [40] S. Panigrahi, P.K. Parhi, K. Sarangi, K.C. Nathsarma, *Sep. Purif. Technol.*, 70 (2009) 58-62.
- [41] C. Foulon, D. Pareau, M. Stambouli, G. Durand, *Hydrometallurgy*, 54 (1999) 49-63.
- [42] U. Pancharoen, T. Wongsawa, A.W. Lothongkum, *Separ. Sci. Technol.*, 46 (2011) 2183-2190.
- [43] J. Traeger, J. Konig, A. Stadtke, H.J. Holdt, *Hydrometallurgy*, 127 (2012) 30-38.
- [44] L. Pan, Z.D. Zhang, *Miner. Eng.*, 22 (2009) 1271-1276.
- [45] P.P. Sun, M.S. Lee, *Hydrometallurgy*, 109 (2011) 181-184.

- [46] S. Chaturabul, K. Wongkaew, U. Pancharoen, *Sep. Purif. Technol.*, 48 (2013) 93-104.
- [47] C. Fontàs, C. Palet, V. Salvadó, M. Hidalgo, *J. Membr. Sci.*, 178 (2000) 131-139.
- [48] S.C. Roy, J.V. Sonawane, N.S. Rathore, A.K. Pabby, P. Janardan, R.D. Changrani, P.K. Dey, S.R. Bharadwaj, *Separ. Sci. Technol.*, 43 (2008) 3305-3332.
- [49] D. Buachuang, P. Ramakul, N. Leepipatpiboon, U. Pancharoen, *J. Alloys. Compd.*, 509 (2011) 9549-9557.
- [50] T. Pirom, K. Wongkaew, T. Wannachod, U. Pancharoen, N. Leepipatpiboon, *J. Ind. Eng. Chem.*, <http://dx.doi.org/10.1016/j.jiec.2013.07.043>
- [51] C.C. Wang, F.L. Yang, F.G. Meng, H.M. Zhang, Y. Xue, G. Fu, *Bioresource Technol.*, 101 (2010) 5469-5474.
- [52] A.W. Lothongkum, P. Ramakul, W. Sasomsub, S. Laoharochanapan, U. Pancharoen, *J. Taiwan Inst. Chem. E.*, 40 (2009) 518-523.
- [53] R. Güell, E. Anticó, V. Salvadó, C. Fontàs, *Sep. Purif. Technol.*, 62 (2008) 389-393.



### CHAPTER III

Purification of Sn(IV) and recovery of Pd(II) from flexible printed circuit board industry wastewater via HFSLM: temperature effect investigation

Krirkratthawit Wongkaew <sup>a</sup>, Niti Sunsandee <sup>b</sup>, Ura Pancharoen <sup>a</sup>,

Kasidit Nootong <sup>a,\*</sup>, Prakorn Ramakul <sup>c,\*</sup>

a Department of Chemical Engineering, Faculty of Engineering, Chulalongkorn University, Bangkok 10330, Thailand

b Government Pharmaceutical Organization, Ratchathevi, Bangkok 10400, Thailand

c Department of Chemical Engineering, Faculty of Engineering and Industrial Technology, Silpakorn University, Nakhon Pathom 73000, Thailand

จุฬาลงกรณ์มหาวิทยาลัย  
CHULALONGKORN UNIVERSITY

---

This article has been published in Journal: Journal of Industrial and Engineering Chemistry. (Page: 217-228). Volume: 22. Year:2015

---

### 3.1 Abstract

Purification of Sn(IV) and recovery of Pd(II) from flexible printed circuit board (FPCB) industry wastewater via HFSLM has been presented. This work examined the influence of extractant concentration in the liquid membrane, HCl concentration, and flow rates of feed and stripping solutions. The thermodynamic properties were also investigated. The results showed that percentage of recovery of Pd(II) was 100% and purify 84% of Sn(IV) remaining in the feed solution. The Sn(IV) and Pd(II) kinetic reaction orders approached 1.0 and the reaction rate constants were read at 0.00301 and 0.08509 min<sup>-1</sup>, respectively. The experimental results were agreed with the mathematical model.

*Keywords:* Liquid membrane; Hollow fiber; Recovery; Stannous; Palladium

---

\*Corresponding author. Tel.: +66 2 218 6864; Fax: +66 2 218 6877.

\*\*Corresponding author. Tel.: +66 3421 9368; Fax: +66 3421 9368.

E-mail address: kasidit.n@chula.ac.th (K. Nootong), prakorn@su.ac.th (P. Ramakul).

### 3.2 Introduction

Flexible printed circuit board (FPCB) technology is an enabling technology for several important applications in various industries, e.g. automobiles, computers, digital cameras, telecommunications, etc. The advantage of this electronic technology is in its effect on performance in the design of flexible circuits, allowing a reduction in their size, weight, assembly time and cost, while continuously enhancing their functionality. The demand for flexible circuits has grown rapidly, at an average annual growth rate (AAGR) of 13.5%, to reach US\$11.2 billion in 2010 and a projected US\$16 billion in 2015 [1]. Nowadays, in most fields the economic situation is highly competitive, particularly in regard to matters such as time of delivery, quality and, perhaps most importantly, product price. As indicated above, this is interrelated with a reduction of production costs go together. However, the specific process flow for producing FPCB must be considered [2]. The five main processes are: computer numerical control process (CNC), direct plating process (DPP), plated through-hole process (PTH) [3], circuit-forming process (CIR), and the final process (FIN). For all five of the processes, since the cause of waste is the DPP process, the activating solution and precious metals (palladium and stannous) are included in the waste. Both of these precious metals have many versatile uses, such as in the jewelry industry [4], in printed circuit boards in the electronics industry [5], in catalytic converters in the automobile industry [6], as dental alloys [7], for plating and coating processes in the steel industry [8], and as catalysts in the petrochemical industry [9], etc.

In practice, multidisciplinary research and technology was used for separation of palladium ions from aqueous solution such as precipitation [10], and solvent extraction [11]. On the other hand, these conventional methods are ineffective at a very dilute concentration of metal ions [12]. Recently, liquid-liquid extraction has been reported as a suitable method for extraction and stripping of palladium and platinum ions from various aqueous solutions by using many extractants [13, 14]. The results proved that this system can be recover palladium ions successfully. However, this system suffers from many disadvantages, i.e., the large inventory, loss of high purity solvents and extractant, as well as the disposal of solvents [15]. In recent years, the separation of metal ions at a very low concentration has been focused on the liquid membrane system. In particular, a hollow fiber supported liquid membrane (HFSLM) is an excellent system for the separation of metal ions at very low concentration (in ppm and ppt) from several solutions. This technique has demonstrated feasibility of application on an industrial scale for separating and increasing the concentration of several metal ions [16, 17]. The advantages of a hollow fiber membrane over traditional separation techniques are its high efficiency, high contact area, high selectivity, low operating costs and energy consumption [18, 19]. A summary of previous works on the separation of stannous and palladium by several methods is shown in **Table 3.1**.

**Table 3. 1** Literature reviews on the separation extraction of palladium and stannous

Author	Method	Feed solution	Extractant	Diluent
Bandekar et al. [13]	SE	Sn(IV), Sb(III), etc.	PC-88A	Toluene
Rane et al. [14]	SE	Pt(IV), Pd(II)	LIX 84-I	Dodecane
Zaghbani et al. [15]	FSSLM	Au(III), Pd(II)	Thiacalix 4	NPOE
Zou et al. [20]	SE	Rh(III), Sn(II),	TBP	No use
Rovira et al. [21]	FSSLM	Pt(IV), Rh(III), Pd(II)	DEHTPA	Kerosene
Patthaweeongka et	HFSLM	Pt(IV), Pd(II), etc.	TRHCl-OA	Chloroform
<b>Uheida</b> et al. [23]	HFSLM	Pd(II)	NTH	Hexane
This work	HFSLM	Pd(II), Sn(IV)	LIX 84-I	Kerosene

**Note:** SE, solvent extraction; FSSLM, flat-sheet supported liquid membrane; and HFSLM, hollow fiber supported liquid membrane

The extraction and stripping reactions of metal ions across HFSLM take place on two interfaces of the feed – membrane and membrane –stripping. Both reactions are in the power of the controlled temperature in the system [24, 25]. A little previous work reported the influence of temperature on the efficiency of extraction and stripping of the target of metal ions across HFSLM. Bautista-Flores et al. [26] reported that an increase in operating temperature ranging 15 °C to 35 °C results in the increasing extraction efficiency for lead (II) separation across HFSLM. Sunsandee et al. [27] reported the efficiency of temperature ranging investigated the effects of temperature ranging from 25 °C – 35 °C on extractability of enantioseparation of (R,S)-amlodipine. Usapein et al.[24] reported the influence of operating temperature on extraction and stripping of Cr(VI). Results noted that the extraction of Cr(VI) increased when the temperature was increased from 20 °C to 50 °C. However, when operating temperature was higher than 40 °C, the lifetime of liquid membrane are

short. Liu and Shi [25] reported that the influence of operating temperature ranging from 15–35 °C on ethylbenzene and nitrobenzene extraction across HFSLM. Results revealed that separation percentage increased when the temperature was increased. It was found that the separation efficiency increased when the operating temperature was raised. Nonetheless, no literature information with respect to influence of temperature on efficiency of palladium ions via a single module HFSLM operation was addressed.

The main objectives of this paper are to present the effect of operating parameters, in particular operating temperature, on efficiency of extraction and stripping of palladium ions from FPCB industrial wastewater across HFSLM. FPCB industrial wastewater containing stannous as an impurity was used as the feed solution. HFSLM was impregnated with LIX84-I which was selected as the extractant as results of its efficiency in separation of palladium ions from various aqueous solution[14].

### 3.3 Theory

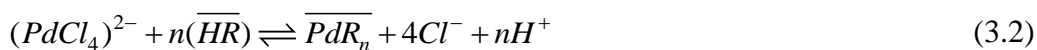
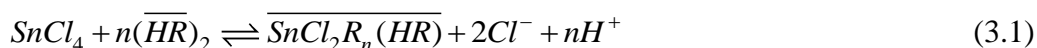
#### 3.3.1 Extraction equilibrium ( $K_{ex}$ )

In HFSLM, the carrier LIX 84-I was dissolved in kerosene to generate an organic solution which was embedded in the hydrophobic micropores of the hollow fiber module. The feed phase was FPCB industrial wastewater that contained Pd(II) and Sn(IV) ions. The properties of the flexible printed circuit board industry wastewater are shown in **Table 3.2**.

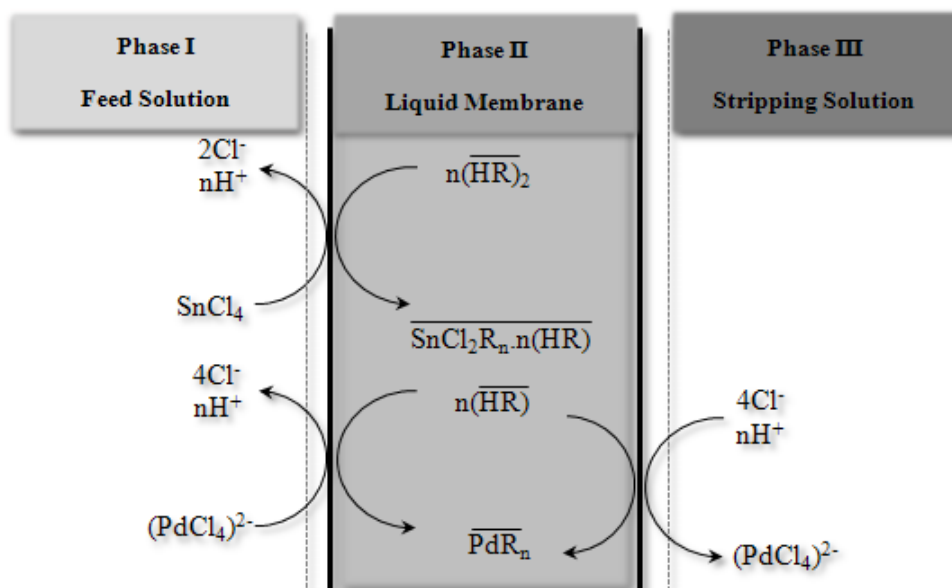
**Table 3. 2** Characteristics of the flexible printed circuit board industry wastewater.

Parameter	Value
Color	Brownish
Temperature (°C)	30
pH	5.2
Sn(IV) (ppm)	400
Pd(II) (ppm)	300
Pt(II) (ppm)	45
Cu(II) (ppm)	5
TSS (mg/L)	750
BOD (mg/L)	1720
COD (mg/L)	3080
Conductivity (µs/cm)	2850

In the HFSLM system, the feed solution was pumped into the inner side while the stripping solution was simultaneously pumped into the outer side of each hollow fiber in the system. The transport mechanism of precious metal ions in the microporous hollow fiber is presented in **Fig. 3.1**. Stannous and palladium ions in the feed solution were in the form  $\text{SnCl}_4$  [20] and  $(\text{PdCl}_4)^{2-}$  [28], respectively. They reacted with LIX 84-I, represented by  $\overline{HR}$ , and occur in complex species form as in Eqs. (3.1) and (3.2) [13, 14]:



The complex species of stannous ( $\overline{\text{SnCl}_2\text{R}_n(\text{HR})}$ ) and palladium ( $\overline{\text{PdR}_n}$ ) in the liquid membrane phase permeated from the feed solution–liquid membrane interface through the liquid membrane–stripping solution interface. At the liquid membrane–stripping interface,  $\overline{\text{PdR}_n}$  complex species reacted with proton ions, as in Eq. (2), while stannous complex species did not react with proton in the stripping solution.



**Fig.3. 1** Counter-transport scheme of  $\text{SnCl}_4$  and  $(\text{PdCl}_4)^{2-}$  extraction and stripping by LIX 84-I.



The efficiencies of the system were defined in terms of % extraction, % stripping as reported elsewhere [29] and % purity could be determined by Eq. (3.3)

$$\% \text{ Purity} = \frac{\text{Actual amount of desired metal}}{\text{Total amount of metals}} \times 100 \quad (3.3)$$

From Eqs. (1) and (2), the extraction equilibrium constants of stannous ( $K_{ex,Sn}$ ) and palladium ( $K_{ex,Pd}$ ) were calculated by Eqs. 3.4(a) and 3.4(b), respectively:

$$K_{ex,Sn} = \frac{[\overline{SnCl_2R_n \cdot n(HR)}][Cl^-]^2[H^+]^n}{[SnCl_4][(HR)_2]^n} \quad 3.4(a)$$

$$K_{ex,Pd} = \frac{[\overline{PdR_n}][Cl^-]^4[H^+]^n}{[(PdCl_4)^{2-}][HR]^n} \quad 3.4(b)$$

### 3.3.2 Distribution ratio (D)

The distribution ratio ( $D$ ) is the ratio between desired metal ions in the organic phase and the desired metal ions in the feed solution phase at equilibrium[30]. For stannous and palladium, the distribution ratio can be rearranged and expressed as:

$$D_{Sn} = \frac{[\overline{SnCl_2R_n \cdot n(HR)}]}{[SnCl_4]} = \frac{K_{ex,sn}[(\overline{HR})_2]^n}{[Cl^-]^2[H^+]^n} \quad 3.5(a)$$

$$D_{Pd} = \frac{[\overline{PdR}_n]}{[(PdCl_4)^{2-}]} = \frac{K_{ex,Pd} [\overline{HR}]^n}{[Cl^-]^4 [H^+]^n} \quad 3.5(b)$$

### 3.3.3 Stoichiometric coefficient (n)

After taking the logarithm to both sides, Eqs. 3.5(a) and 3.5(b) can be rewritten as shown below, where the slope of the linear equation gives the stoichiometric coefficient value ( $n$ ):

$$\log(D_{Sn} [Cl^-]^2) = n \log \left[ \frac{[\overline{HR}]_2}{[H^+]} \right] + \log K_{ex,Sn} \quad 3.6(a)$$

$$\log(D_{Pd} [Cl^-]^4) = n \log \left[ \frac{[\overline{HR}]}{[H^+]} \right] + \log K_{ex,Pd} \quad 3.6(b)$$

### 3.3.4 Determining the permeability coefficient (P)

Considering the mechanism in **Fig. 3.1**, at the interface between the feed and liquid membrane phases, the interfacial reactions were faster and the distribution ratios of metal ions was higher than at the interface between the liquid membrane and stripping phase [18, 21]. The permeability coefficient can be expressed as suggested by Danesi et al. [31]:

$$-V_{feed} \ln \frac{C_{feed}}{C_{feed,0}} = AP \frac{\alpha}{\alpha+1} t \quad (3.7)$$

where  $\alpha = \frac{Q_{feed}}{PL\varepsilon\pi N r_i}$

with the following variables:  $V_{feed}$  is the volume of the feed solution;  $C_{feed, 0}$  and  $C_{feed}$  are the precious metal concentrations at time 0 and t, respectively;  $A$  is the effective area of the hollow fiber module;  $P$  is the permeability coefficient;  $t$  is the time;  $Q_{feed}$  is the volumetric flow rate of the feed solution;  $L$  is the length;  $\varepsilon$  is the porosity of the hollow fiber;  $N$  is the number of hollow fibers in the module; and  $r_i$  is the internal radius of the hollow fiber. From Eq. (3.7), by plotting  $[-V_{feed} \ln (C_{feed}/C_{feed, 0})]$  as a function of time ( $t$ ), the slope in terms of  $[AP \{ \alpha / (\alpha+1) \}]$  was obtained. Finally, the term of the permeability coefficient can be calculated.

### 3.3.5 Mass transfer modeling

The relationship between the mass transfer coefficient and the permeability coefficient ( $P$ ) is used to determine the mass transfer coefficients of stannous and palladium ion diffusion through the HFSLM. The permeability coefficient depends on three mass transfer resistances, as shown in Eq. (3.8). The first resistance occurs in the aqueous flow through the hollow fiber lumen. The second resistance is from the metal complexes permeating through the liquid membrane and becoming immobilized on the porous wall of the fiber. The third resistance is due to the stripping solution and organic interface outside of the fiber.

$$\frac{1}{P} = \frac{1}{k_i} + \frac{r_i}{r_{lm}} \frac{1}{P_m} + \frac{r_i}{r_o} \frac{1}{k_s} \quad (3.8)$$

where:  $k_i$  is the aqueous mass transfer coefficient in the tube side;  $k_s$  is the stripping mass transfer coefficient in the shell side;  $r_{lm}$  is the log-mean radius of the hollow fiber,  $r_{lm} = (r_o - r_i) / \ln(r_o / r_i)$ ;  $r_o$  is the external radius of the hollow fiber; and  $P_m$  is the membrane permeability coefficient.

The relation between the membrane permeability coefficient ( $P_m$ ) and the distribution ratio ( $D$ ) is shown in Eq. (3.9) [32]:

$$P_m = D k_m \quad (3.9)$$

By substituting  $D_{Sn}$  and  $D_{Pd}$  from Eqs. 3.5(a) and 3.5(b), respectively, into Eq. (3.9), 3.10(a) and 3.10(b) were obtained:

$$P_{m,Sn} = \frac{K_{ex,Sn} k_{m,Sn} \left[ \frac{(\overline{HR})_2}{2} \right]^n}{[Cl^-]^2 [H^+]^n} \quad 3.10(a)$$

$$P_{m,Pd} = \frac{K_{ex,Pd} k_{m,Pd} \left[ \frac{(\overline{HR})}{2} \right]^n}{[Cl^-]^4 [H^+]^n} \quad 3.10(b)$$

By substituting  $P_{m, Sn}$  and  $P_{m, Pd}$  from Eqs. 3.10(a) and 3.10(b) into Eq. (3.8), assuming the stripping reaction is instantaneous and the contribution of the stripping

phase is neglected [33],  $P_{m, Sn}$  and  $P_{m, Pd}$  can be expressed as in Eqs. 3.11(a) and 3.11(b), respectively.

The permeability coefficient of stannous ( $P_{Sn}$ ):

$$\frac{1}{P_{Sn}} = \frac{1}{k_{i,Sn}} + \frac{r_i}{r_{lm}} \frac{1}{\frac{K_{ex,Sn} k_{m,Sn} [(HR)_2]^n}{[Cl^-]^2 [H^+]^n}} \quad 3.11(a)$$

The permeability coefficient of palladium ( $P_{Pd}$ ):

$$\frac{1}{P_{Pd}} = \frac{1}{k_{i,Pd}} + \frac{r_i}{r_{lm}} \frac{1}{\frac{K_{ex,Pd} k_{m,Pd} [HR]^n}{[Cl^-]^4 [H^+]^n}} \quad 3.11(b)$$

### 3.3.6 Effect of temperature on extraction equilibrium

The effect of temperature on the extraction equilibrium constants ( $K_{ex}$ ) of Sn(IV) and Pd(II) was directly related to the van't Hoff equation. This equation is related to standard Gibbs free energy and the Gibbs–Helmholtz equation, as in [34, 35].

Since  $\Delta G^o = -RT \ln K_{eq}$ ,

$$\text{then } \ln K_{eq} = -\frac{\Delta G^o}{RT} \quad 3.12(a)$$

The relation of Gibbs free energy with the enthalpy and entropy follows as in Eq. 3.12

(b) [35]:

$$\Delta G^o = \Delta H^o - T\Delta S^o \quad 3.12(b)$$

By substituting Eq. 3.12(b) into Eq. 3.12(a), the van't Hoff equation in linear form was obtained, as shown in Eq. 3.12(c):

$$\ln K_{eq} = -\frac{\Delta H^o}{RT} + \frac{\Delta S^o}{R} \quad 3.12(c)$$

### 3.3.7 Hollow fiber model for extraction of stannous (IV) and palladium (II)

The extraction Eqs. (3.1) and (3.2) can be simplified as follows:



Where  $A$  is stannous or palladium ions,  $B$  is an extractant,  $C$  is the complex species of stannous or palladium ions in the organic phase,  $D$  is proton, and  $E$  is chloride ions in the feed solution. The suffixes  $a$ ,  $b$ ,  $c$ ,  $d$  and  $e$  are stoichiometric coefficients. The reaction rate of  $A$ ,  $-r_A$ , can be described as follows:

$$-r_A = k_f C_A^m(x, t) \quad (3.14)$$

where  $k_f$  is the reaction rate constant (L/mol)<sup>m-1</sup>/time,  $C_A(x, t)$  is the concentration of stannous or palladium ions (mol/L) at time  $t$ ,  $m$  is the reaction order and  $t$  is time (min).

The mathematical model of the hollow fiber supported liquid membrane system that was developed by Pancharoen et al. [36] was applied to this work. The conservation of mass for Sn(IV) and Pd(II) ion transport in the hollow fiber can be expressed by Eq. 3.15(a):

$$-\frac{Q}{A_c} \frac{\partial}{\partial x} C_A(x, t) - \frac{A_p}{A_c} \varepsilon \cdot r_A(x, t) = \frac{\partial}{\partial t} C_A(x, t) \quad 3.15(a)$$

Previous work [22] showed that the reaction order of palladium extraction was equal to 1 ( $m = 1$ ):

at initial time ( $t = 0$ ):

$$C_A(x, 0) = C_A(0, 0) \exp\left(-\frac{k_f A_p x}{Q}\right), \quad 0 \leq x \leq L \quad 3.15(b)$$

at any time ( $t$ ):

$$\bar{C}_A(L, t) = \exp\left(-k_f \frac{A_p}{A_c} \varepsilon \cdot \tau_0\right) \bar{C}_A(0, t - \tau_0) \cdot u(t - \tau_0) \quad 3.15(c)$$

where  $u(t - \tau_0)$  is a unit function;

$$u(t-\tau_0)=0, t < \tau_0$$

$$u(t-\tau_0)=1, t \geq \tau_0$$

let

$$\bar{C}_A(L, t) = C_A(L, t) - C_A(L, 0)$$

$$\tau_0 = \frac{A_C L}{Q}$$

when  $A_C$  is the cross-sectional area of a hollow fiber ( $\text{cm}^2$ ) and  $Q$  is the volumetric flow rate (mL/min).

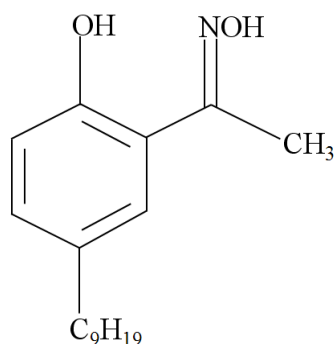
## 3.4 Experimental

### 3.4.1 Feed solution and reagents

The activating waste solution from PCTT Ltd., Thailand, included Sn(IV) and Pd(II) ions dissolved in hydrochloric acid solution. In order to eliminate dirt, the wastewater solution was filtered with filter paper (Whatman No. 42) via a vacuum pump. A sequential inductively coupled plasma spectrometer (ICPS-7000; Shimadzu Corp., Kyoto, Japan) was used for metals determination. The results showed that the initial concentrations of stannous and palladium were 400 and 300 ppm, respectively. LIX 84-I, used as an extractant, was supplied by Henkel Thailand Ltd. (Bangkok). The chemical structure of LIX 84-I is shown in **Fig.3.2**. The liquid membrane diluent was commercial grade kerosene from Thai Oil Public Co., Ltd. (Bangkok). Analytical



grade hydrochloric acid, supplied by Merck Co., Ltd. (Thailand) was used as the stripping solution.



**Fig.3. 2** The chemical structure of LIX 84-I.

### 3.4.2 HFSLM apparatus

The HFSLM apparatus consisted of a Liqui-Cel<sup>®</sup> Extra-Flow 2.5 × 8 laboratory liquid/liquid extraction module (Celgard, Charlotte NC, USA), two chemical gear pumps, two variable speed controllers, two rotameters and four pressure gauges. The liquid/liquid extraction module was composed of 35,000 polypropylene fibers. The properties of the hollow fiber module are shown in **Table 3.3**.

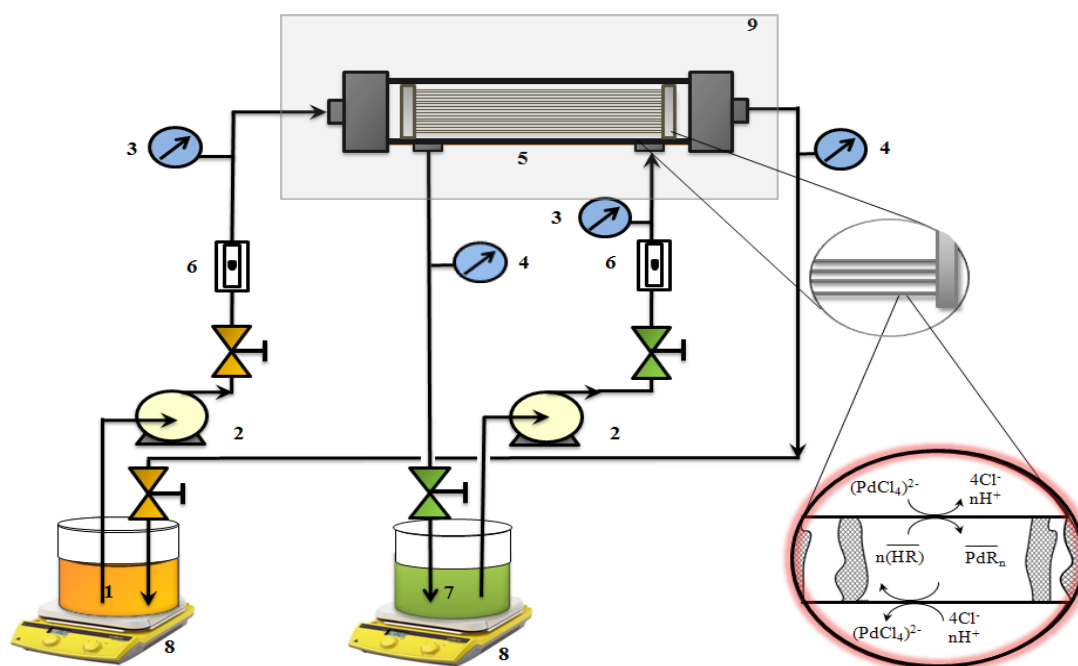
**Table 3. 3** Characteristics of the hollow fiber module.

Attributes	Details
Material	Polypropylene
Diameter of module	0.063 m
Number of hollow fibers	35,000
Inside diameter of a hollow fiber	$2.4 \times 10^{-4}$ m
Outside diameter of a hollow fiber	$3.0 \times 10^{-4}$ m
Effective length of a hollow fiber	0.203 m
Contact area	$1.4 \text{ m}^2$
Area per unit volume	$2.93 \times 10^3 \text{ m}^2/\text{m}^3$
Pore size	$3 \times 10^{-8}$ m
Porosity	30%
Tortuosity	2.6
Operating temperature	10 – 60 °C

### 3.4.3 Procedures

A single hollow fiber module operation for the purification of stannous and the recovery of palladium ions is shown in **Fig. 3.3**. The separation mechanism consisted of three steps. The first step was preparation of the HFSLM module by feeding organic solution (extractant dissolved in kerosene) into the tube side of the hollow fiber module for 40 min to ensure that the extractant was embedded into the micropores of the hollow fibers. The second step was simultaneously pumping the feed solution into the tube side and stripping solution into the shell side of the HFSLM module in a counter-current flow pattern. The temperature of the system was maintained by using a stirrer with temperature control. Finally, the samples from the feed and stripping solutions were taken every 10 min for 60 min; the concentrations

of stannous and palladium ions in the samples were determined by ICPS-7000. The accuracy of the measurements was calculated in term uncertainty not more than 1%.

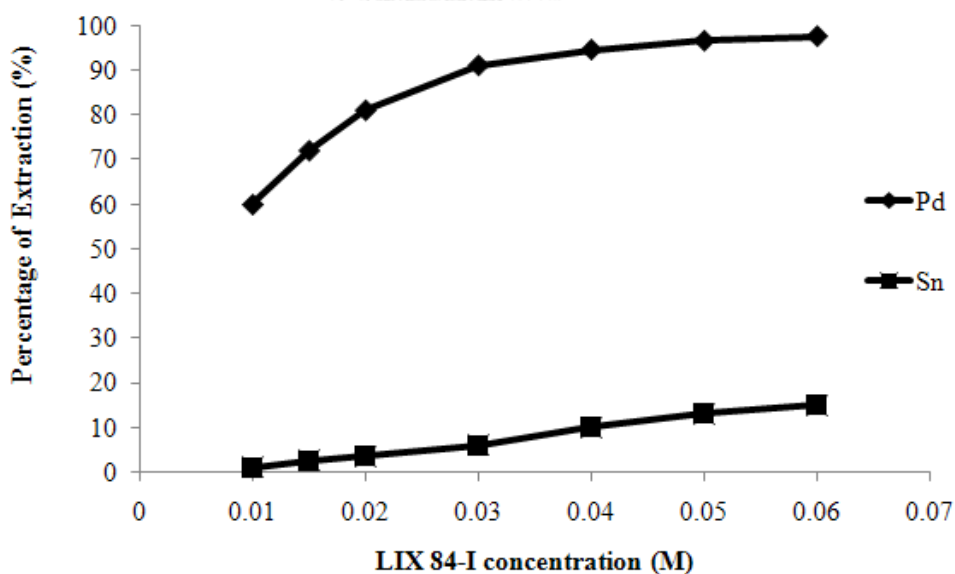


**Fig.3.** Schematic counter-current flow diagram for a single-module operation in the HFSLM: 1) feed reservoir, 2) gear pumps, 3) inlet pressure gauges, 4) outlet pressure gauges, 5) hollow fiber module, 6) flow meters, 7) stripping reservoir, 8) stirrer with temperature control, and 9) temperature control box.

### 3.5 Results and discussion

#### 3.5.1 Effect of LIX 84-I concentration on the extractability of Sn(IV) and Pd(II)

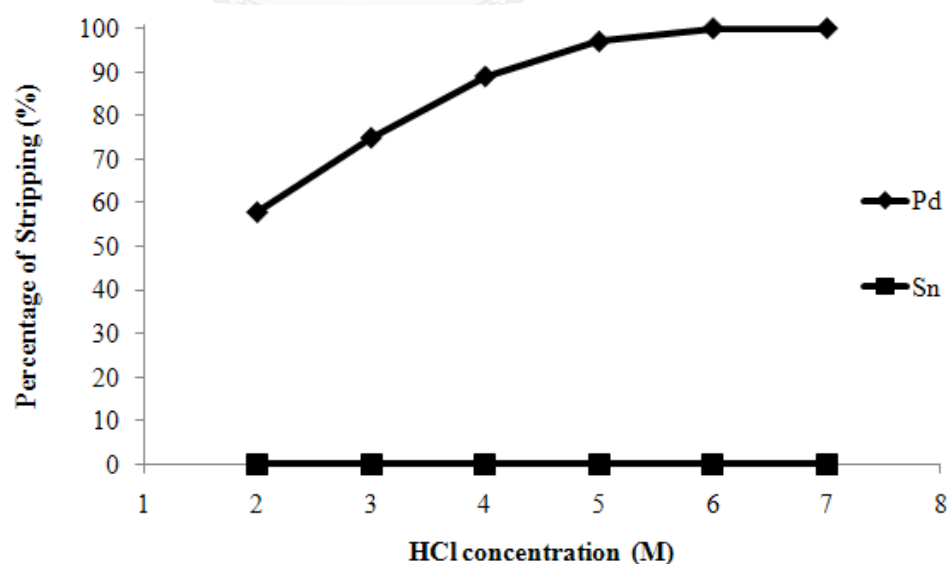
In order to investigate the effect of extractant concentration in the liquid membrane, LIX 84-I concentrations were varied from 0.01 M to 0.06 M, as indicated in **Fig. 3.4**. Sn(IV) and Pd(II) extraction percentages increased with increasing LIX 84-I concentration, which was in agreement with Le Chatelier's principle. An LIX 84-I concentration of 0.06 M gave the highest extraction efficiency for stannous and palladium of 15% and 97.5%, respectively.



**Fig.3. 4** Percentage of extraction against LIX 84-I concentration: pH of feed solution = 3; strip solution using 6 M of hydrochloric acid;  $Q_{feed} = Q_{strip} = 100$  ml/min; temperature 20 °C.

### 3.5.2 Effect of stripping solution concentration

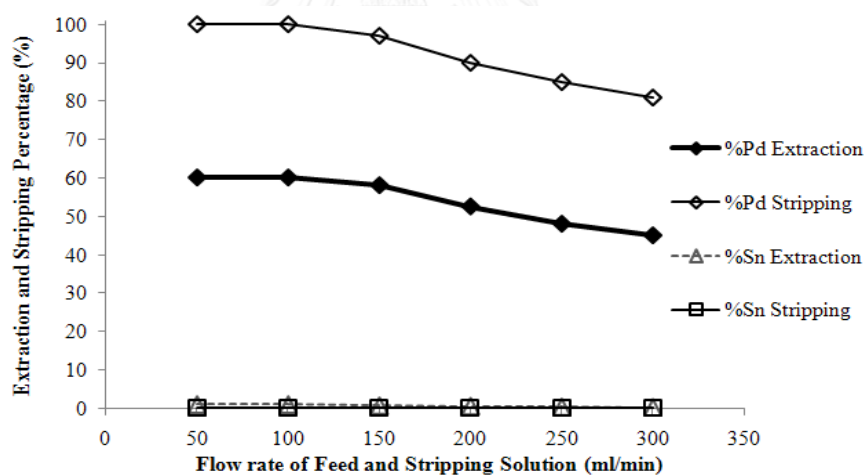
The effect of HCl concentration in the stripping solution on the efficiency of Sn(IV) and Pd(II) recovery were also investigated; the results are shown in **Fig. 3.5**. It can be inferred that the stannous ions cannot be recovered using any HCl concentration because the stannous ions did not react with proton in the stripping solution [37]. However, when the HCl concentration in the stripping solution was increased from 2.0 M to 7.0 M, the stripping percentage of palladium increased, which is in accordance with Eq. (2). The recovery of palladium ions reached a maximum value with 6.0 M concentration of HCl solution. Above this concentration, the recovery of palladium ions increased only slightly. Therefore, 6.0 M concentration of HCl was accepted as the best stripping solution concentration.



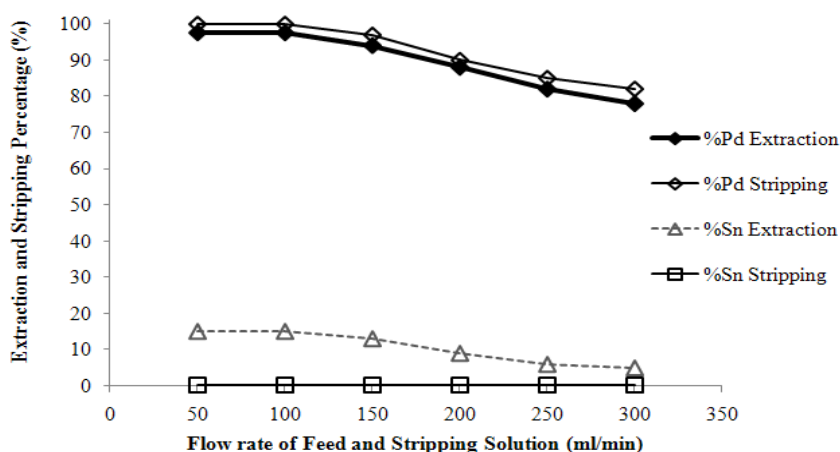
**Fig.3. 5**The percentage of stripping against HCl concentrations: LIX 84-I 0.01 M, pH of feed = 3,  $Q_{feed} = Q_{strip} = 100$  ml/min, temperature 20 °C.

### 3.5.3 Effects of flow rate of feed and stripping solutions

The flow rate during extraction is an important factor. Effects of flow rate on the extraction of stannous and palladium ions are shown in **Fig. 3.6**. As seen from **Fig. 3.6**, stannous and palladium extraction decreased by increasing the flow rate. This decreasing can be explained by decreased residence time in the range of 10 to 30 min of the solution in the hollow fiber module [13]. For stannous recovery, the flow rate did not influence stannous ion recovery because stannous ions do not react with proton in the stripping solution [37]. Hence, a flow rate of 100 mL/min was chosen as the optimum flow rate.



(a)

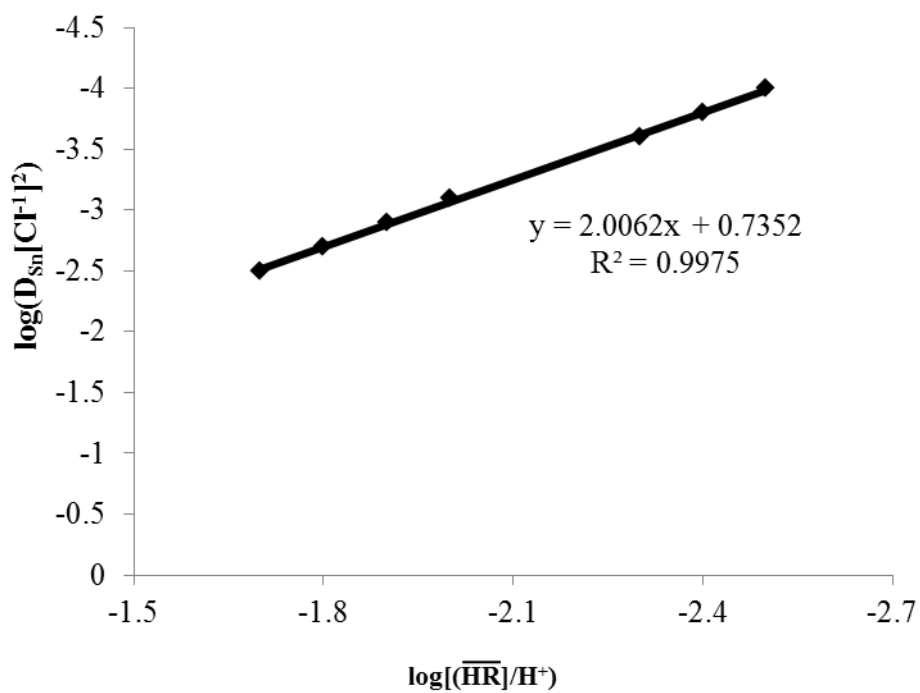


(b)

**Fig.3. 6** Extraction and stripping percentages of stannous and palladium ions against flow rate of feed and stripping solutions: (a) LIX 84-I 0.01 M; (b) LIX 84-I 0.06 M (pH of feed = 3; strip solution = 6 M of hydrochloric acid; system temperature = 20 °C).

### 3.5.4 Stoichiometric coefficient of Sn(IV) and Pd(II) extraction with LIX 84-I

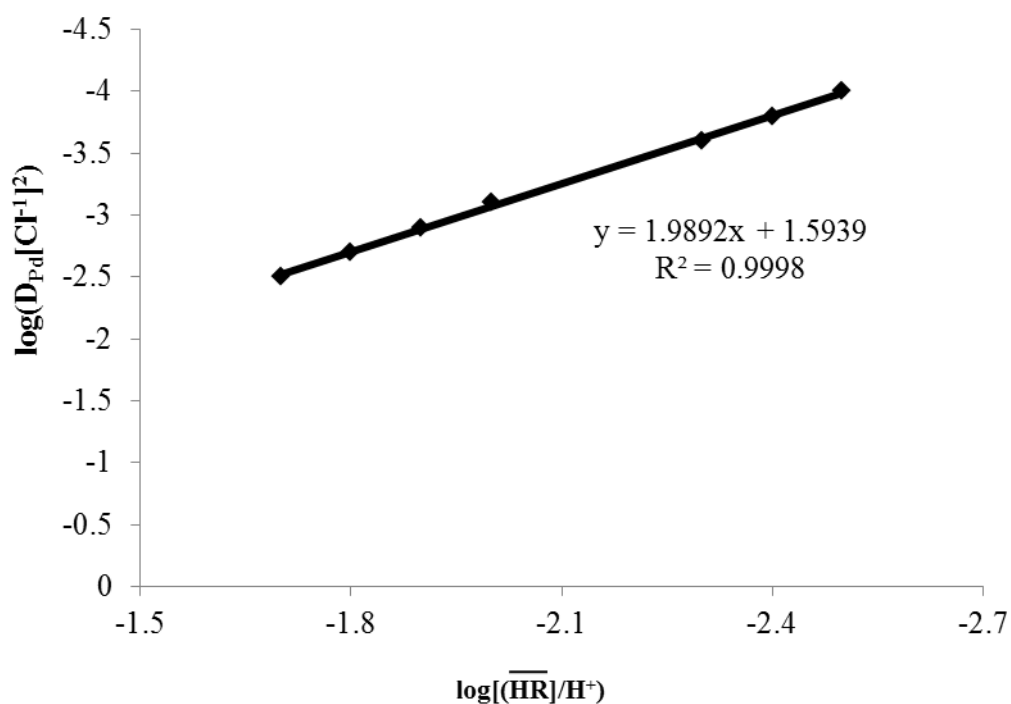
The stoichiometric coefficients of stannous and palladium extraction with varying amounts of LIX 84-I were calculated by Eqs. 3.6(a) and 3.6(b). From these equations, we can plot  $\log(D_{Sn} \cdot [Cl^-]^2)$  versus  $\log\left(\frac{[(\overline{HR})_2]}{[H^+]}\right)$  for stannous extraction, as shown as **Fig. 3.7**.



**Fig.3. 7** Plot of  $\log(D_{Sn} \cdot [Cl^-]^2)$  versus  $\log \frac{[(\overline{HR})_2]}{[H^+]}$ .

In the same way, for palladium extraction we can plot  $\log(D_{Pd} \cdot [Cl^-]^4)$  versus  $\log\left(\frac{[\overline{HR}]}{[H^+]}\right)$ . The result is shown in **Fig. 3.8**.





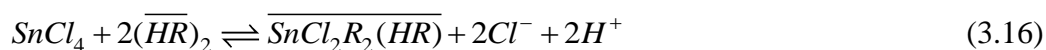
**Fig.3. 8** Plot of  $\log\left(D_{Pd} \cdot [Cl^-]^4\right)$  versus  $\log\left(\frac{[HR]}{[H^+]}\right)$ .

**Figs. 3.7 and 3.8** show that both slopes of the linear equation line give a stoichiometric coefficient  $n$  value equal to 2. This implies that LIX 84-I reacted with Sn(IV) in a ratio of 2:1 and reacted with Pd(II) in a ratio of 2:1. These ratios are in agreement with the findings of Bandekar et al. [13] and Rane et al. [14], respectively.

### 3.5.5 Extraction equilibrium constant

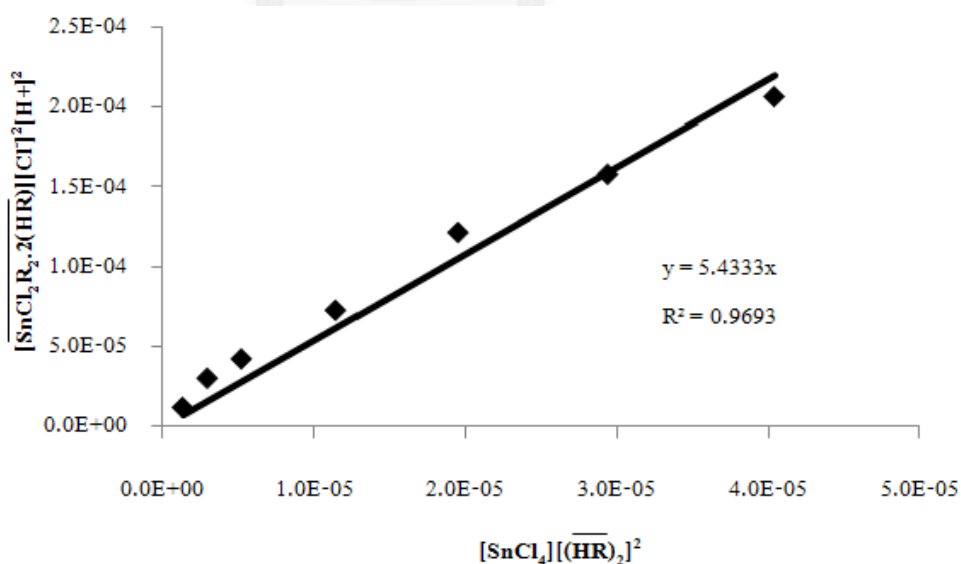
From the previous results of determining the stoichiometric coefficient value of stannous and palladium extraction with LIX 84-I, we can substitute  $n = 2$  into Eqs.

(3.1), (3.2), 3.4(a) and 3.4(b) as shown in the following equations. For the extraction reaction of stannous, the equilibrium constant is shown as:



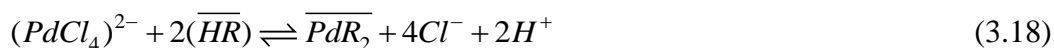
$$K_{ex,Sn} = \frac{[\overline{\text{SnCl}_2\text{R}_2 \cdot 2(\text{HR})}][\text{Cl}^-]^2[\text{H}^+]^2}{[\text{SnCl}_4][(\overline{\text{HR}})_2]^2} \quad (3.17)$$

From the stannous equilibrium in Eq. (17), the result is shown in **Fig. 3.9**, the plot of  $[\overline{\text{SnCl}_2\text{R}_2 \cdot 2(\text{HR})}][\text{Cl}^-]^2[\text{H}^+]^2$  versus  $[\text{SnCl}_4][(\overline{\text{HR}})_2]^2$ . The equilibrium constant stannous extraction value ( $K_{ex, Sn}$ ) can be determined from the slope of the linear equation of  $5.433 \text{ (mol/L)}^2$ .



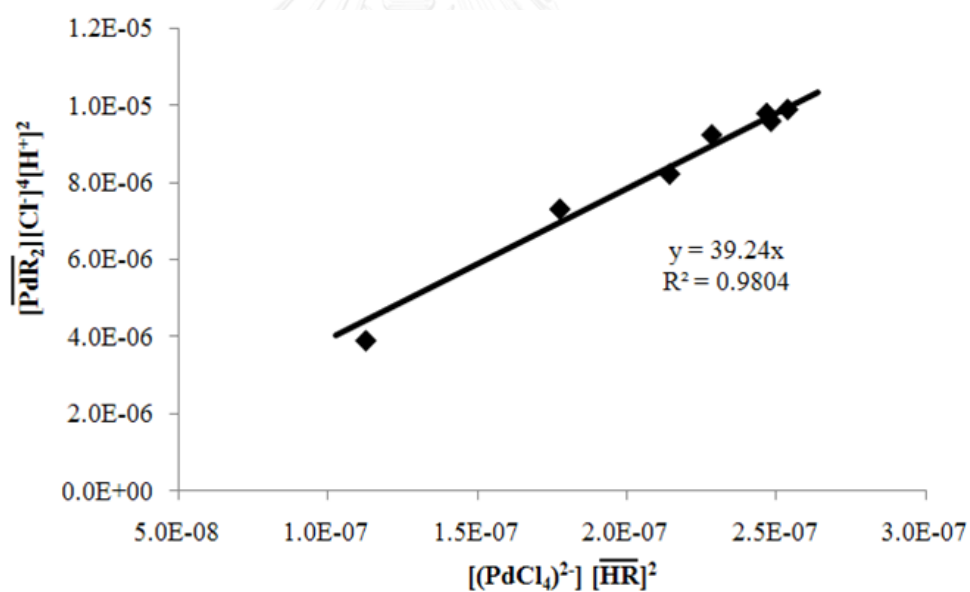
**Fig.3. 9** Fitting of the equilibrium constant of stannous extraction with LIX 84-I.

The extraction reaction of palladium and the equilibrium constant were rewritten as:



$$K_{ex, Pd} = \frac{[\overline{PdR_2}] \cdot [Cl^-]^4 \cdot [H^+]^2}{[(PdCl_4)^{2-}] \cdot [\overline{HR}]^2} \quad (3.19)$$

By the same way, the palladium equilibrium in Eq. (3.19), the relation between  $[\overline{PdR_2}][Cl^-]^4[H^+]^2$  and  $[(PdCl_4)^{2-}][\overline{HR}]^2$  was plotted; the results are shown in **Fig. 3.10**. The equilibrium constant palladium extraction value ( $K_{ex, Pd}$ ) is 39.24 (mol/L)<sup>2</sup>.



**Fig.3. 10** Fitting of the equilibrium constant of palladium extraction with LIX 84-I.

### 3.5.6 The distribution ratios

The distribution ratios were calculated by substituting the stoichiometric coefficient of 2 ( $n = 2$ ) into Eqs. 3.5(a) and 3.5(b), while the LIX 84-I concentrations were varied from 0.01 M to 0.06 M, as shown in **Table 3.4**.

**Table 3.4** Distribution ratios for different concentrations of LIX 84-I.

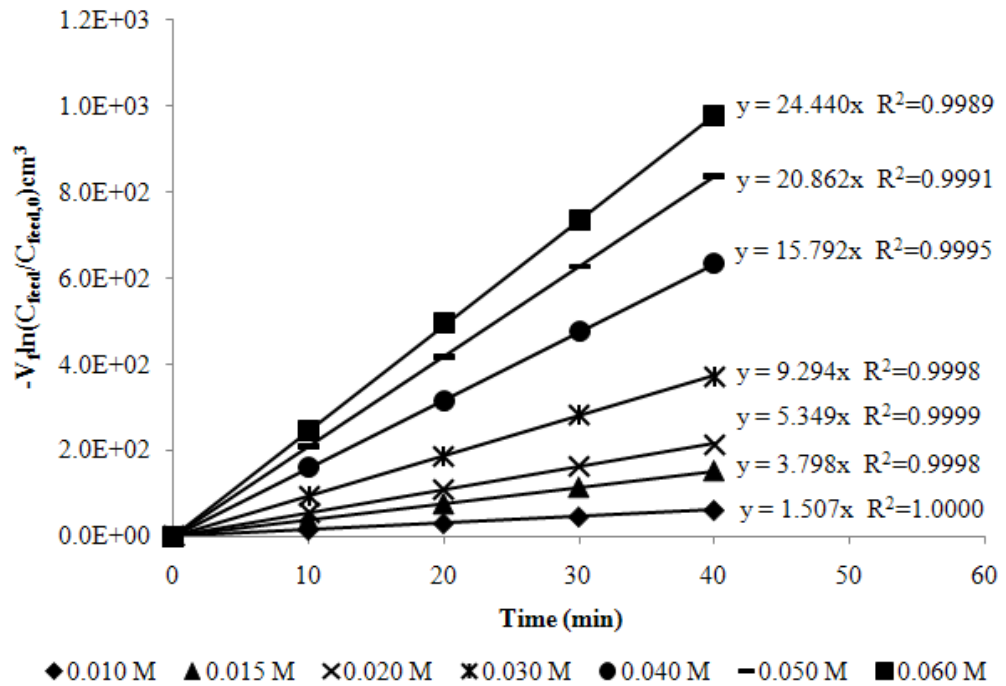
LIX 84-I (M)	0.010	0.015	0.020	0.030	0.040	0.050	0.060
$D_{Sn}$	0.006±	0.014±	0.024±	0.054±	0.097±	0.151±	0.217±
	0.001	0.001	0.001	0.001	0.001	0.001	0.001
$D_{Pd}$	1.090±	2.453±	4.360±	9.810±	17.440±	27.250±	39.240±
	0.001	0.001	0.001	0.001	0.001	0.001	0.001

It was observed that the increasing the LIX 84-I concentration in the liquid membrane from 0.01 M to 0.06 M increased both the stannous and palladium distribution ratios. According to the extraction equations in Eqs. (3.1) and (3.2), increasing the carrier concentration increases the forward reaction. This phenomenon is consistent with Le Chatelier's theory, and agrees with Pancharoen et al. [38].

### 3.5.7 Calculation of permeability

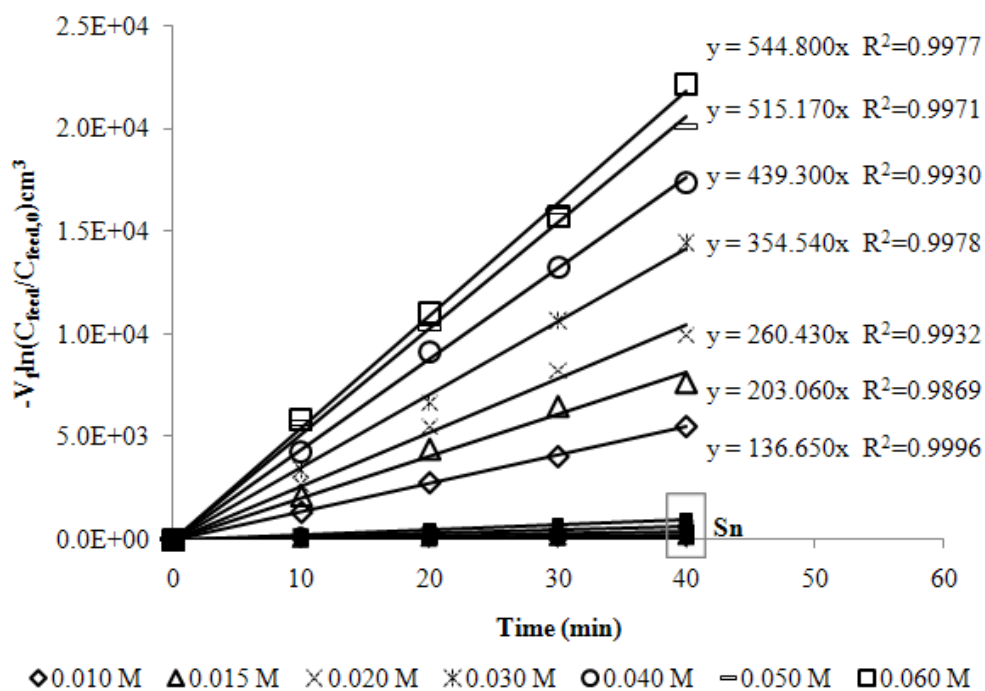
According to the experimental results and Eq. (7),  $V_{feed} \ln (C_{feed}/C_{feed, 0})$  versus time, was plotted and considered the function of LIX 84-I concentration

increasing from 0.01 M to 0.06 M. Results of stannous and palladium extraction are shown in **Figs. 3.11** and **3.12**, respectively.



**Fig.3. 11** Plot of  $-V_{feed} \ln (C_{feed}/C_{feed,0})$  of stannous ions in the feed solution against time, with different LIX 84-I concentrations.

From **Figs. 3.11** and **3.12**, the term  $\left(-AP \left[\frac{\phi}{\phi+1}\right]\right)$  was obtained by the slope of the linear equation line. The permeability coefficients ( $P$ ) of stannous and palladium extraction were calculated as a function of LIX 84-I concentration increasing from 0.01 M to 0.06 M as shown in **Table 3.5**.



**Fig.3. 12** Plot of  $-V_{feed} \ln (C_{feed}/C_{feed, 0})$  of palladium ions in the feed solution against time, with different LIX 84-I concentrations.

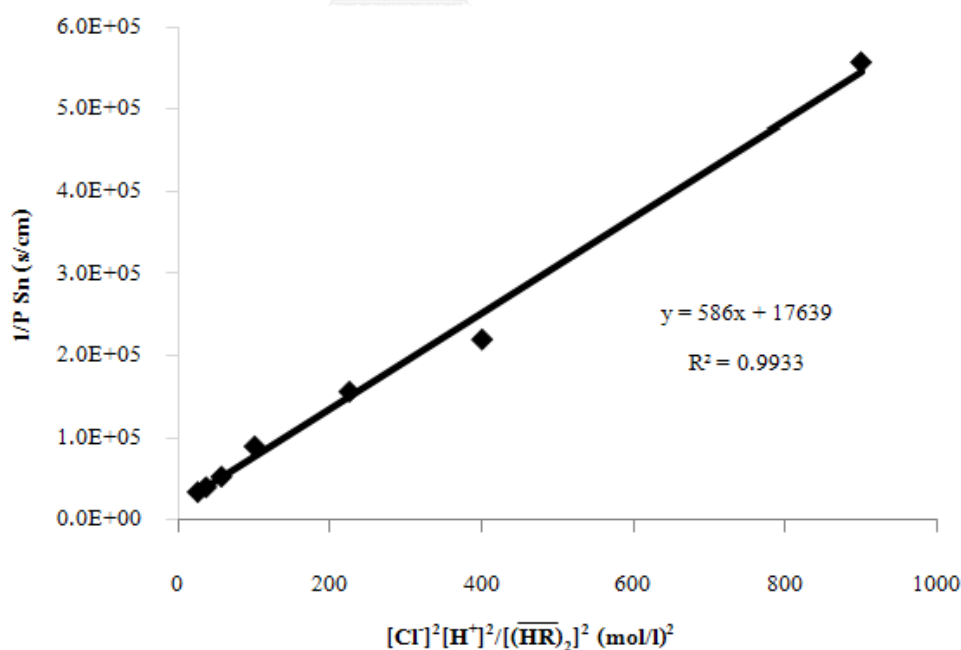
**Table 3. 5** The permeability of stannous and palladium ions with different concentrations of LIX 84-I.

LIX 84-I (M)	0.010	0.015	0.02	0.03	0.04	0.05	0.06
$P_{Sn}$ (cm/s $\times 10^4$ )	0.018 $\pm 0.002$	0.046 $\pm 0.002$	0.064 $\pm 0.002$	0.112 $\pm 0.002$	0.193 $\pm 0.002$	0.257 $\pm 0.002$	0.303 $\pm 0.002$
$P_{Pd}$ (cm/s $\times 10^4$ )	2.096 $\pm 0.002$	3.623 $\pm 0.002$	5.409 $\pm 0.002$	10.070 $\pm 0.002$	18.670 $\pm 0.002$	39.374 $\pm 0.002$	60.500 $\pm 0.002$

As seen in **Table 3.5**, with increasing LIX 84-I concentration from 0.01 M to 0.06 M, the permeability coefficients of both stannous and palladium increased because increasing the carrier concentration resulted in an increase of the forward reaction, in agreement with Le Chatelier's principle. Therefore, 0.06 M of LIX 84-I in the liquid membrane was selected as the best carrier concentration.

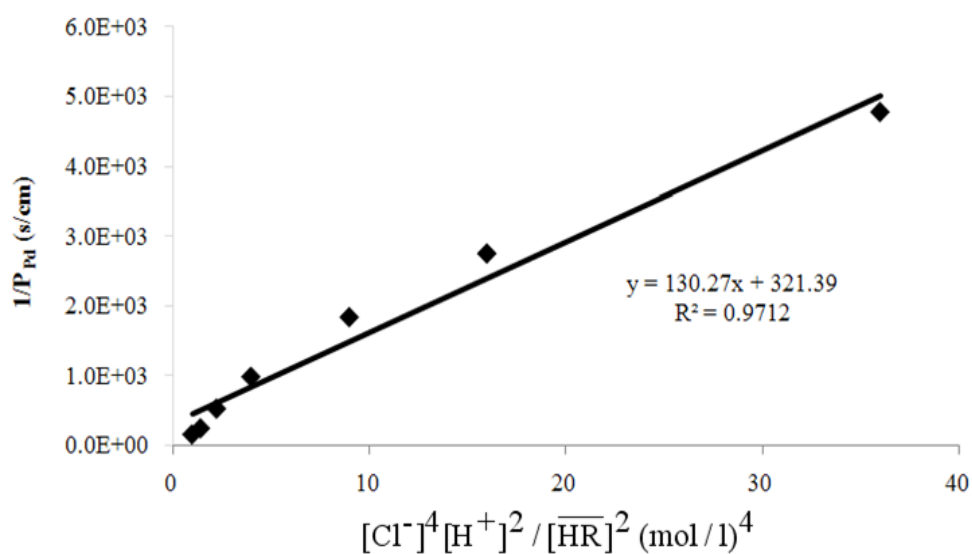
### 3.5.8 Mass transfer coefficients

The mathematical model of the HFSLM depends on three mass transfer resistances, which were applied to this work as Eq. 3.11(a) for stannous extraction and Eq. 3.11(b) for palladium extraction. For stannous extraction, we can plot the term of  $(1/P_{Sn})$  as a function of  $([Cl^-]^2[H^+]^2 / [(HR)_2]^2)$  against increasing LIX 84-I concentration, as shown in **Fig. 3.13**.



**Fig.3. 13** Plot of  $1/P_{Sn}$  as a function of  $[Cl^-]^2[H^+]^2 / [(HR)_2]^2$ .

The mass transfer coefficient can be determined from slope and intercept of linear equation, respectively.  $k_{i, Sn}$  and  $k_{m, Sn}$  are equal to  $5.7 \times 10^{-5}$  and  $2.18 \times 10^{-4}$  cm/s, respectively.



**Fig.3. 14** Plot of  $1/P_{Pd}$  as a function of  $[Cl^-]^4[H^+]^2 / [HR]^2$ .

By the same way, referring to Eq. 3.11(b), for palladium extraction we can plot the term  $(1/P_{Pd})$  as a function of  $([Cl^-]^4[H^+]^2 / [HR]^2)$  against increasing LIX 84-I concentration as shown in **Fig. 3.14**.

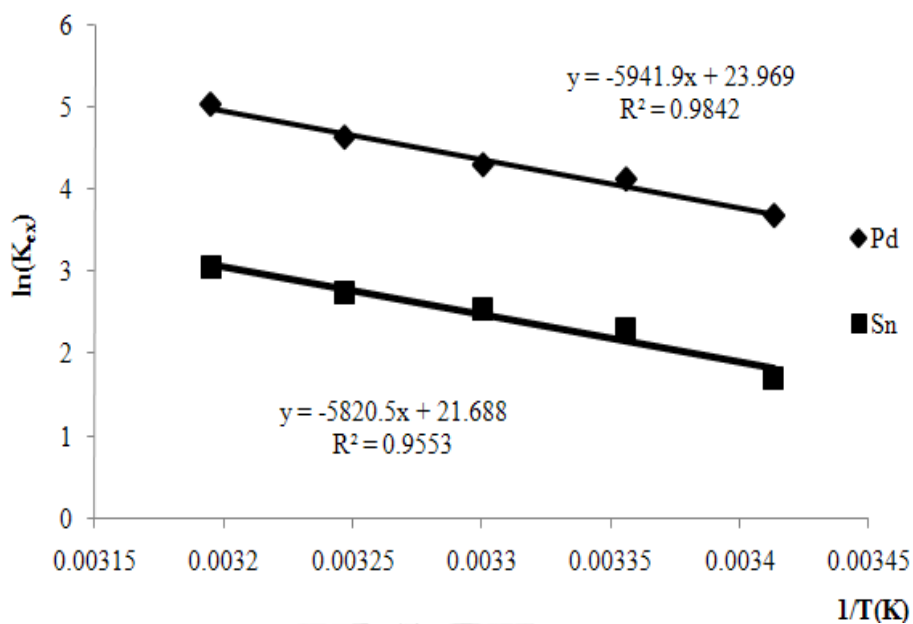
The mass transfer coefficient can be obtained by the slope of the linear equation line, and the intercept gives the term  $1/k_{i, Pd}$ .  $k_{i, Pd}$  and  $k_{m, Pd}$  are equal to  $3.11 \times 10^{-3}$  and  $1.75 \times 10^{-4}$  cm/s, respectively. The mass transfer coefficient has a profound influence on the extraction behavior that follows from the HFSLM mechanism. Therefore, the mass transfer coefficient is directly proportional to transport efficiency. In the case of stannous behavior, the membrane mass transfer coefficient ( $k_{m, Sn}$ ) was



higher than the aqueous mass transfer coefficient ( $k_{i,Sn}$ ). This indicated that the aqueous mass transfer coefficient of stannous ( $k_{i,Sn}$ ) is the mass transfer-controlling step. In the same way, in the case of palladium behavior, the aqueous mass transfer coefficient ( $k_{i,Pd}$ ) was higher than the membrane mass transfer coefficient ( $k_{m,Pd}$ ). This shows that the membrane mass transfer coefficient ( $k_{m,Pd}$ ) is the rate-controlling step.

### 3.5.9 Effect of temperature on extraction equilibrium

According to Eqs. 3.12(a) and 3.12(b), the plot in term  $\ln(K_{ex})$  versus  $1/T$ , considered as a function of temperature increasing from 20 °C to 40 °C. The HFSLM system used the conditions of LIX 84-I concentration of 0.01 M, and feed and stripping flow rates equal to 100 mL/min. The result for stannous and palladium extraction is displayed in **Fig. 3.15**. The values of  $\Delta H$  and  $\Delta S$  for stannous extraction were 48.4 kJ/mol and 180 J/(mol·K), and for palladium extraction were 49.4 kJ/mol and 199.0 J/(mol·K). The positive values of  $\Delta H$  indicate that the extraction of stannous and palladium are endothermic reactions. The positive  $\Delta S$  and the negative  $\Delta G$  value indicate that the reaction proceeds as a forward reaction. These values from analytical calculation are shown in **Table 3.6**.



**Fig.3. 15** Plots of  $\ln(K_{ex, Sn})$  and  $\ln(K_{ex, Pd})$  versus  $1/T$ .

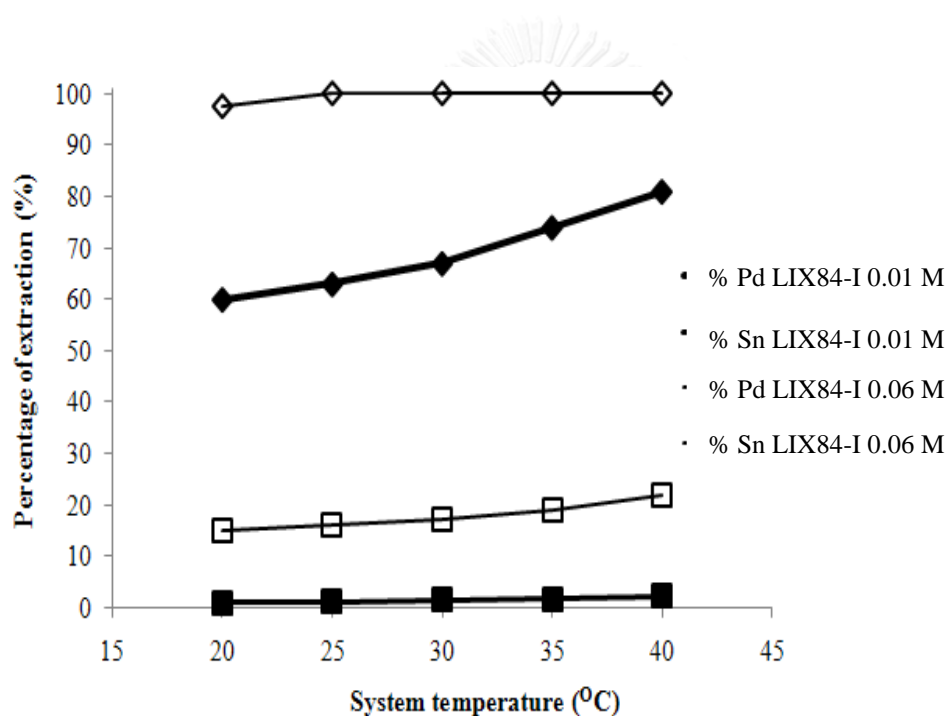
**Table 3. 6** Thermodynamic data for Sn(IV) and Pd(II) in LIX 84-I 0.01 M.

Temperature (°C)	$K_{ex, Sn}$	$K_{ex, Pd}$	$\Delta G^{\circ}_{Sn}$ (KJ/mol)	$\Delta G^{\circ}_{Pd}$ (KJ/mol)	$D_{Sn}$	$D_{Pd}$
20	5.4	39.2	-8.4	-8.9	0.00 6	1.09 0
25	10.0	61.3	-9.8	-10.2	0.01 1	1.70 3
30	12.8	73.1	-10.5	-10.8	0.01 4	2.03 0
35	15.6	102. 5	-11.2	-11.9	0.01 7	2.84 6

		153.			0.02	4.26
40	21.2		-11.9	-13.1		
		5			0	3

Note:  $Q_{feed} = Q_{strip} = 100$  ml/min

Consequently, the effect of temperature on the extent of extraction was considered as a function of temperature increasing from 20 °C to 40 °C, and was



**Fig.3. 16** Plot of percentage of extraction versus system temperature. ( $Q_{feed} = Q_{strip} = 100$  mL/min.)

From **Fig. 3.16**, when the temperature of the HFSLM was increased from 20 °C to 40 °C, the extraction percentage of stannous and palladium increased, in agreement with Eq. (3.23). The optimal conditions for purification of stannous and

recovery of palladium is 0.06 M of LIX 84-I, 6 M of HCl in stripping solution, and a system temperature of 25 °C. It is possible to purify 84% of stannous that remains in the feed solution, and to recover 100% of palladium in the stripping solution.

### 3.5.10 Verification of the model with the experimental results for Sn(IV) and Pd(II)

#### 3.5.10.1 Reaction order

In this work, the reaction orders ( $m$ ) from Eq. 3.15(a) of Sn(IV) and Pd(II) extractions were verified by differential method [39]. The various LIX 84-I concentrations were 0.01 M, 0.02 M, 0.04 M and 0.06 M, using a system temperature of 20 °C. Combining the mole balance with the rate law equation given by Eq. (3.14) results in Eq. 3.20(a):

$$-\frac{dC_A}{dt} = k_f C_A^m \quad 3.20(a)$$

After taking the logarithm of both sides of the equation:

$$\log\left(-\frac{dC_A}{dt}\right) = m \log C_A + \log k_f \quad 3.20(b)$$

From Eq. 3.20(b), when we plot the term  $(\log[-dC_A/dt])$  versus  $[\log C_{A,average}(x,t)]$ , the slope of the linear equation will give the reaction order  $m$  value,

and the intercept is  $\log k_f$ . The reaction order and reaction rate constant were calculated for a variety of concentrations of LIX 84-I, as shown in **Table 3.7**.

**Table 3.7** Reaction order and reaction rate constants.

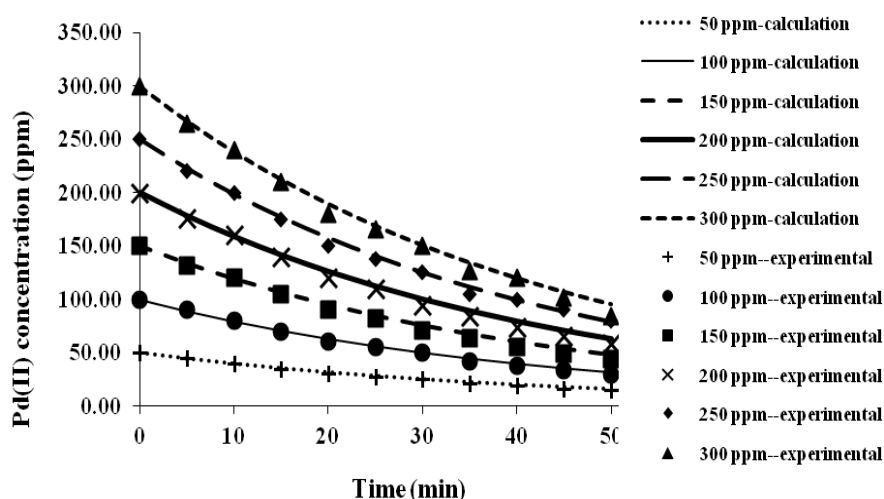
LIX 84-I (M)	Sn(IV)			Pd(II)			Result
	Slope = m	$k_f$ (min <sup>-1</sup> )	$R^2$	Slope = m	$k_f$ (min <sup>-1</sup> )	$R^2$	
0.01	0.7318	0.00035	0.7247	1.2039	0.00700	0.7232	Reject
0.02	0.8036	0.00079	0.8074	1.1312	0.02326	0.7562	Reject
0.04	0.9723	0.00272	0.8844	1.0289	0.06126	0.8967	Reject
0.06	1.0262	0.00301	0.9885	0.9874	0.08509	0.9942	Accept

CHULALONGKORN UNIVERSITY

From the calculated results in **Table 3.7**, it was found that when LIX 84-I concentration increased, the reaction rate constant was likewise increased due to Eq. 3.20(a). The suitable LIX 84-I concentration was represented by an  $R^2$  value which approached 1. Under optimal conditions, the reaction order for stannous and palladium are approximately 1.

### 3.5.10.2 Comparison of experimental data and mathematical model calculation

All of the experimental results were compared with the mathematical model in Eqs. 3.15(b) and 3.15(c), as shown in **Fig. 3.17**. Eqs. 3.15(b) and 3.15(c), were used to predict the concentration of Pd(II) at different times for different extractant concentrations. The computational results (solid line) were in good agreement with the experimental data (dashed line). Based on this result, it can be concluded that the reaction flux model is satisfactory for the separation of Pd(II) through a hollow fiber supported liquid membrane. It is a simple mathematical model which can be easily used to predict the concentration of metal separation in the feed tank for the recirculating mode of an HFSLM system.



**Fig.3. 17** Different concentrations of Pd(II) in the feed phase, plotted as a function of time.

### 3.6 Conclusion

Purification of stannous ions and recovery of palladium was achieved by HFSLM using LIX 84-I. Under optimal experimental conditions, 100% of palladium

can be recovered from FPCB industrial wastewater solution and 84% of stannous remaining in the feed solution can be purified. The stoichiometric coefficient ( $n$ ) of LIX 84-I for the combination of Sn(IV) and Pd(II) is equal to 2.0. The optimal conditions consist of a LIX 84-I concentration equal to 0.06 M, 6 M HCl stripping solution, a volumetric flow rate of feed and stripping solutions equal to 100 mL/min, and a system temperature of 25 °C. The mass transfer coefficients of the aqueous feed,  $k_{i, Sn}$  and  $k_{i, Pd}$ , were  $5.70 \times 10^{-5}$  and  $3.11 \times 10^{-3}$  cm/s, respectively. The organic phase mass transfer coefficients,  $k_{m, Sn}$  and  $k_{m, Pd}$ , were  $2.18 \times 10^{-4}$  and  $1.75 \times 10^{-4}$  cm/s, respectively. Therefore, the rate-controlling step for Sn(IV) is the diffusion of stannous through the film layer between the feed and the liquid membrane. On the other hand, the rate-controlling step for Pd(II) is the diffusion of palladium complex through the liquid membrane. The kinetic reaction order of both Sn(IV) and Pd(II) ( $m$ ) is equal to 1.0, and the reaction rate constants are 0.00301 and 0.08509 min<sup>-1</sup>, respectively.

### 3.7 Nomenclature

$A$	effective area of the membrane (cm <sup>2</sup> )
$A_c$	cross-sectional area of a hollow fiber (cm <sup>2</sup> )
$A_p$	area of micropores of a hollow fiber (cm <sup>2</sup> )
$C$	concentration (mg/L) or (gmol/L)
$D$	distribution ratio [-]
$G$	Gibbs free energy (kJ/mol)
$H$	enthalpy (kJ/mol)

$k$	mass transfer coefficient [cm/s] or reaction rate constant ( $\text{min}^{-1}$ )
$K$	equilibrium constant [-]
$L$	length of a fiber (cm)
$m$	reaction order [-]
$n$	stoichiometric coefficient
$N$	number of hollow fibers in the module [-]
$P$	permeability (cm/s)
$Q$	volumetric flow rate ( $\text{cm}^3/\text{min}$ )
$r$	rate of the reaction ( $\text{mol/L}\cdot\text{min}$ ), or radius (cm)
$R$	gas constant ( $8.314 \text{ J/mol}\cdot\text{K}$ )
$S$	entropy ( $\text{J/mol}\cdot\text{K}$ )
$t$	time (min)
$T$	temperature ( $^{\circ}\text{C}$ )
$V$	volume ( $\text{cm}^3$ )
$x$	direction of fiber axis

*Greek Letters*

$\tau_0$	constant in Eq. (27)
$\varepsilon$	porosity of hollow fiber [-]

*Subscripts*

ex	extraction
feed	feed phase
i	internal or aqueous phase
m	membrane
o	external



$I_m$	log-mean
Pd	palladium ions
Sn	stannous ions
strip	stripping phase

### **3.8 Acknowledgements**

The authors greatly appreciate financial support by the Thailand Research Fund through the Royal Golden Jubilee Ph.D. Program (Grant No.PHD/0297/2550), the Integrated Innovation Academic Center (IIAC), Chulalongkorn University Centenary Academic Development Project (RES 560530019), the Department of Chemical Engineering, Faculty of Engineering and Industrial Technology, Silpakorn University. Many thanks are given to the Separation Laboratory, Department of Chemical Engineering, Faculty of Engineering, Chulalongkorn University, Bangkok, Thailand, for chemical and apparatus support. Thanks are also given to PCTT Ltd. for kindly supplying the wastewater solution as well as to the Government Pharmaceutical Organization (GPO), Thailand, for kindly supplying all instruments for analysis and measurement.

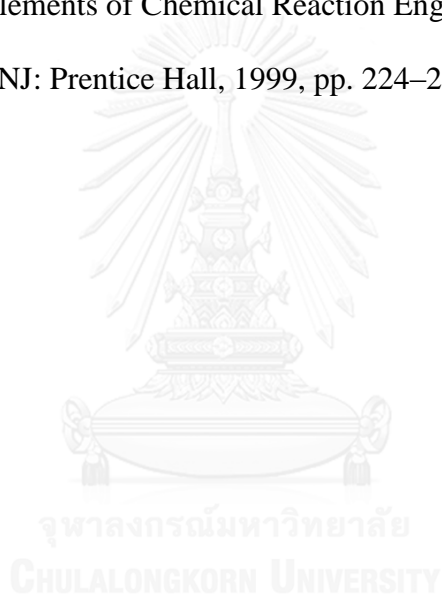
### 3.9 References

- [1] Electronics Industry Market Research and Knowledge Network,  
<http://www.electronics.ca/presscenter/articles/1242/1/Global-Flexible-Printed-Circuit-Boards-Market-to-Exceed-16-Billion-by-2015/Page1.html> (accessed 01.03.14).
- [2] C.F. Coombs Jr., Printed Circuits Handbook, 5th ed. New York: McGraw-Hill, 2002, pp. 28.5–31.14, 58.1–58.17.
- [3] N. Patton, Flexible PCBs and plating through holes: challenges and solutions. *CircuiTree*, 18(9) (2005) 44–50.
- [4] R.W. Hesse, *Jewelrymaking through History: an Encyclopedia*. Westport, CT: Greenwood Publishing Group, 2007, p. 146. .
- [5] J. LaDou, *Int. J. Hyg. Environ. Health*, 209 (2006) 211-219.
- [6] G. Asimellis, N. Michos, I. Fasaki, M. Kompitsas, *Spectrochimica Acta, Part B*, 63 (2008) 1338-1343.
- [7] W.H. Guo, W.A. Brantley, W.A.T. Clark, J.Z. Xiao, E. Papazoglou, *Dent. Mater.*, 19 (2003) 334-340.
- [8] N.D. Nam, M.J. Kim, Y.W. Jang, J.G. Kim, *Corros. Sci.*, 52 (2010) 14-20.
- [9] A.K. Aboul-Gheit, A.E. Awadallah, S.M. El-Kossy, A.L.H. Mahmoud, *J. Nat. Gas. Chem.*, 17 (2008) 337-343.

- [10] A. Dakshinamoorthy, P.S. Dhama, P.W. Naik, N.L. Dudwadkar, S.K. Munshi, P.K. Dey, V. Venugopal, *Desalination*, 232 (2008) 26-36.
- [11] V.S. Kislik, in Chapter 5 - Examples of Application of Solvent Extraction Techniques in Chemical, Radiochemical, Biochemical, Pharmaceutical, Analytical Separations, and Wastewater Treatment, pp. 185-314, Elsevier, Amsterdam (2012).
- [12] S. Suren, U. Pancharoen, N. Thamphiphit, N. Leepipatpiboon, *J. Membr. Sci.*, 448 (2013) 23-33.
- [13] S.V. Bandekar, P.M. Dhadke, *Talanta*, 46 (1998) 1181-1186.
- [14] M.V. Rane, V. Venugopal, *Hydrometallurgy*, 84 (2006) 54-59.
- [15] A. Zaghbani, R. Tayeb, M. Dhahbi, M. Hidalgo, F. Vocansonc, I. Bonnamour, P. Seta, M.A. Fontas, *Sep. Purif. Technol.*, 57 (2007) 374-379.
- [16] Y.D. Jagdale, P.V. Vernekar, A.W. Patwardhan, A.V. Patwardhan, S.A. Ansari, P.K. Mohapatra, V.K. Manchanda, *Sep. Sci. Technol.*, 48 (2013) 2454-2467.
- [17] P.V. Vernekar, A.W. Patwardhan, A.V. Patwardhan, S.A. Ansari, P.K. Mohapatra, V.K. Manchanda, *Sep. Sci. Technol.*, 48 (2013) 1003-1014.
- [18] R. Prakorn, P. Weerawat, U. Pancharoen, H. Milan, *J. Chin. Inst. Chem. Eng.*, 36 (2005) 459-465.
- [19] U. Pancharoen, R. Prakorn, P. Weerawat, *J. Ind. Eng. Chem.*, 11 (2005) 926-931.
- [20] M. Garcia-Gabaldon, V. Perez-Herranz, J. Garcia-Anton, J.L. Guinon, *Sep. Purif. Technol.*, 45 (2005) 183-191.
- [21] M. Rovira, A.M. Sastre, *J. Membr. Sci.*, 149 (1998) 241-250.

- [22] P. Weerawat, V. Nattaphol, U. Pancharoen, *Korean J. Chem. Eng.*, 20 (2003) 1092-1096.
- [23] A. Uheida, Y. Zhang, M. Muhammed, *J. Membr. Sci.*, 241 (2004) 289-295.
- [24] P. Usapein, A.W. Lothongkum, P. Ramakul, U. Pancharoen, *Korean J. Chem. Eng.*, 26 (2009) 791-798.
- [25] Y. Liu, B. Shi, *Sep. Purif. Technol.*, 65 (2009) 233-242.
- [26] A.N. Bautista-Flores, E.R.D. Miguel, J. de Gyves, J.A. Jonsson, *J. Membr. Sci.*, 363 (2010) 180-187.
- [27] N. Sunsandee, N. Leepipatpiboon, P. Ramakul, T. Wongsawa, U. Pancharoen, *Sep. Purif. Technol.*, 102 (2013) 50-61.
- [28] M.A. Barakat, M.H.H. Mahmoud, Y.S. Mahrous, *Appl. Catal. A-Gen.*, 301 (2006) 182-186.
- [29] T. Wongsawa, N. Leepipatpiboon, N. Thamphiphit, U. Pancharoen, A.W. Lothongkum, *Chem. Eng. J.*, 222 (2013) 361-373.
- [30] J.D. Seader, E.J. Henley, *Separation Process Principles*. New York: John Wiley & Sons, 1998.
- [31] P.R. Danesi, *J. Membr. Sci.*, 20 (1984) 231-248.
- [32] N.S. Rathore, J.V. Sonawane, A. Kumar, A.K. Venugopalan, R.K. Singh, D.D. Bajpai, J.P. Shukla, *J. Membr. Sci.*, 189 (2001) 119-128.
- [33] F.Z. El Aamrani, A. Kumar, L. Beyer, A. Florido, A.M. Sastre, *J. Membr. Sci.*, 152 (1999) 263-275.
- [34] W. Greiner, L. Neise, H. Stöcker, *Thermodynamics and Statistical Mechanics*. New York: Springer-Verlag, 1995.

- [35] F. Angulo-Brown, L.A. Arias-Hernández, J. Phys. Chem., 100 (1996) 9193-9195.
- [36] U. Pancharoen, T. Wongsawa, A.W. Lothongkum, Sep. Sci. Technol., 46 (2011) 2183-2190.
- [37] L.H. Zou, J. Chen, X.J. Pan, Hydrometallurgy, 50 (1998) 193-203.
- [38] U. Pancharoen, S. Somboonpanya, S. Chaturabul, A.W. Lothongkum, , J. Alloy Compd., 489 (2010) 72-79.
- [39] H.S. Fogler, Elements of Chemical Reaction Engineering, 3rd edition. Upper Saddle River, NJ: Prentice Hall, 1999, pp. 224–226.



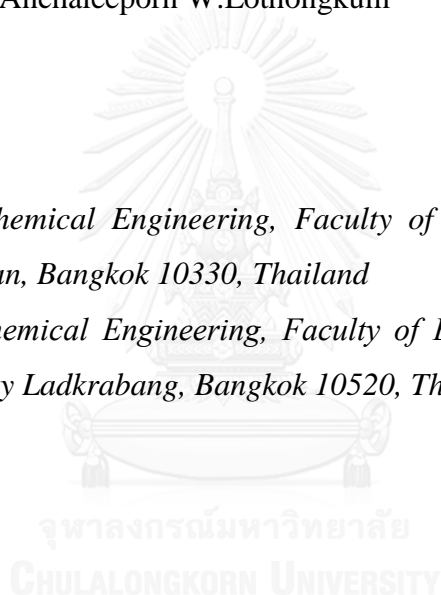
**CHAPTER IV**

Mass transfer resistance and response surface methodology for separation of platinum (IV) across hollow fiber supported liquid membrane

Krirkratthawit Wongkaew<sup>a</sup>, Thanaporn Wannachod<sup>a</sup>, Ura Pancharoen<sup>a,\*</sup>, Amornchai Arpornwichanop<sup>a,\*\*</sup>, Anchaleeporn W.Lothonkum<sup>b</sup>

*a: Department of Chemical Engineering, Faculty of Engineering, Chulalongkorn University, Pathumwan, Bangkok 10330, Thailand*

*b: Department of Chemical Engineering, Faculty of Engineering, King Mongkut's Institute of Technology Ladkrabang, Bangkok 10520, Thailand*



---

This article has been published in Journal: Journal of Industrial and Engineering Chemistry.

(Page: 23-35). Volume: 42. Year:2016

---

#### 4.1 Abstract

The separation of platinum (IV) from wastewater across hollow fiber supported liquid membrane was successful in reaching 96% extraction and 88% stripping using 10%(v/v) trioctylmethyl-ammonium chloride (Aliquat 336) as the extractant. The mass transfer resistances were  $(1/k_a)$   $3.297 \times 10^4$  s/cm,  $(1/k_m)$   $0.164 \times 10^4$  s/cm,  $(1/k_o)$   $3.404 \times 10^4$  s/cm and  $(1/K)$   $6.865 \times 10^4$  s/cm. The system was governed by the mass transfer resistance from the liquid-membrane. Response surface methodology was used to qualify and estimate the influence of operating conditions. Predicted model with experimental data were in good agreement at a standard deviation of 1%.

\*Corresponding author. Tel.: +66 2 218 6891; Fax: +66 2 218 6877.

E-mail addresses: [ura.p@chula.ac.th](mailto:ura.p@chula.ac.th)

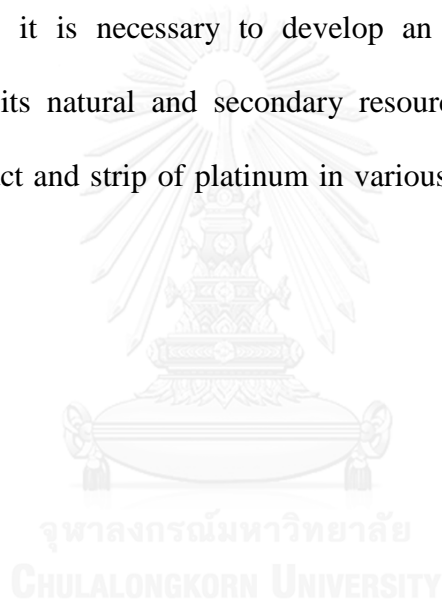
\*\* Corresponding author. Tel.: + 66 2 218 6999; Fax: 662 218 6877.

E-mail addresses: [amornchai.a@chula.ac.th](mailto:amornchai.a@chula.ac.th)

**Keywords:** response surface methodology; platinum (IV); Aliquat 336; mass transfer; hollow fiber supported liquid membrane

## 4.2 Introduction

Platinum occurs as only 0.003 ppb in the Earth's crust and is 30 times rarer than gold [1]. Platinum is currently receiving much attention as a precious metal due to its wide use in various industries [1]. It is employed as an alloy material, as a whitening agent in jewelry, and as an automobile catalyst. Its demand is increasing constantly. However, resources of platinum are limited. Hence, its value has increased. Therefore, it is necessary to develop an effective system to recover platinum from both its natural and secondary resources [2, 3]. The conventional systems used to extract and strip of platinum in various systems are shown in **Table 4.1**.





**Table 4. 1** Summary of previous works on separation of platinum (IV) using different methods.

Authors	Metals	Extractants	Diluents	Stripping	Methods	%Ext Pt(IV)	Ref
Sun et al.	Pt(IV) & Pd(II)	Alamine 336	toluene	thiourea in HCl	LLE	99	[4]
Sun et al.	Pt(IV)& Rh(III)	AGMP-1	N/A	NaCl	IE	99.9	[5]
Lee et al.	Pt(IV)& Rh(III)	Alamine 308	kerosene	thiourea in HCl	LLE	98	[6]
Gupta et al.	Pt(IV),Pd(II) & Rh(III)	Cyanex 923	toluene	HClO <sub>4</sub>	LLE	100	[7]
Sun et al.	Pt(IV)& Rh(III)	TOPO	toluene	thiourea in HCl	LLE	99	[8]
Aleksandar et al.	Pt(IV),Pd(II) & Rh(III)	XUS 43600	N/A	thiourea	Adsorption	99.9	[9]
Michael et al.	Pt(IV) & Ru(III)	N/A	N/A	N/A	Adsorption	90	[10]
Thi et al.	Pt(IV)& Pd(II)	Aliquat 336+TBP	kerosene	thiourea in HCl	LLE	99.9	[11]
This work	Pt(IV) from Pd(II), Au(III),Cu(II) and Zn(II)	Aliquat 336 and LIX84-I, Cyanex923, TBP & TOPO	kerosene	thiourea in HCl	HFSLM	>98	

Note: LLE= liquid liquid extraction; IE= ion exchange and HFSLM=hollow fiber supported liquid membrane

Many publications, as reported in the literature [12-15], have demonstrated that the HFSLM system is a highly effective method for the separation of metal ions

from various aqueous solutions. HFSLM can, in one single-step operation, simultaneously extract and strip a relatively low concentration of metal ions, making this process considerably attractive [16]. This process can overcome conventional methods since it is low in energy consumption, has low operating costs, and uses less chemicals [17]. HFSLM has a high surface area and is easily scalable for commercial application [18]. Moreover, HFSLM can be connected in series in order to improve both extraction and stripping processes. It has also been successfully employed in a wide variety of applications e.g. food [19], water treatment [20], gas separation [21], and pharmaceutical wastewater [22]. Further reviews of the HFSLM system for the separation of metal ions are reported elsewhere [15, 23, 24]. Although the HFSLM system has many advantages, loss of the liquid membrane from the micro-pore of hollow fibers, influencing on both the permeation flux and selectivity, has always been an obstacle to its adoption for large-scale applications.

As stated, the extremely important disadvantage of HFSLM is the fouling of the hollow fibers causing a reduction in the active area of the membrane and therefore a reduction in flux and process productivity over time. Fouling can be minimized by regular cleaning intervals. The concepts of membrane fouling and cleaning were explained Li & Chen [25] such as membrane surface modification, new module designs and etc.

In order to study the relationship of several parameters, response surface methodology (RSM) was undertaken by employing a set of mathematics and statistics. RSMs are most valuable for the design of experiments, assessing the influence of parameters and determining the optimized parameters for a particular response. A central composite design (CCD) assists by fitting the gathered

experimental data into an empirical, second-order polynomial equation. Furthermore, CCD along with a second-order polynomial equation provides a satisfactory representation of most continuous response surfaces over a relatively broad factor domain [26]. Gupta et al. applied RSM in order to optimize operating conditions for extraction of mercury across the system of pseudo-emulsion hollow fiber with strip dispersion. It was noted that regression analysis revealed that the percentages of extraction of mercury up to 98% can be obtained under optimized conditions [27].

In the HFSLM system, mass transfer is the sum of the mass of metal ions investigated, transporting from feed phase to stripping phase [28]. Various works have been reported on the mass transfer coefficient for transport of metal ions across HFSLM [14, 29]. Li et al. [30] studied the mass transfer coefficient for transportation of fumaric acid across HFSLM using trialkylamine as extractants. It was observed that the mass transfer resistance in the feed of boundary layer, the diffusion resistance across the liquid membrane and the mass transfer resistance from the stripping boundary layer were the rate controlling steps.

In this study, the efficiency of the HFSLM system on the separation of platinum (IV) from wastewater was evaluated by selecting different commercial extractants such as 2-hydroxy-5-nonylaceto-phenone oxime (LIX84), a mixture of four trialkyl-phosphine oxides (Cyanex 923), trioctylmethyl-ammonium chloride (Aliquat 336), tri-n-butylphosphate (TBP) and trioctylphosphine oxide (TOPO). The influences of types and concentrations of different extractants on percentages of extraction and stripping of platinum (IV) were further explored as well as the distribution ratio, permeability coefficients and overall mass transfer coefficients. In order to determine optimum values of operating parameters, RSM was applied by utilizing face-centered

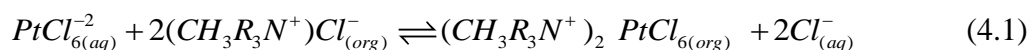
central composite design (CCF). Three variables undertaken for CCF were  $X_1$ (concentration of platinum (IV) in feed phase),  $X_2$ (concentration of Aliquat 336 in the liquid membrane phase) and  $X_3$ (concentration of  $\text{NH}_2\text{CSNH}_2$  in HCl in the stripping phase). Finally, the optimized conditions were employed to separate platinum (IV) from gold refining wastewater, kindly supplied by Gold Field Refinery Co. Ltd, Thailand.

### 4.3 Theory

#### 4.3.1 Transport of platinum (IV) across the liquid membrane phase

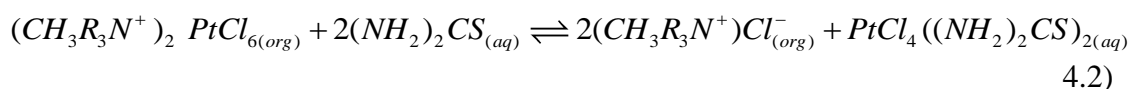
The separation of platinum (IV) using Aliquat 336 as the extractant involved facilitated coupled counter-transport through HFSLM. Transportation of platinum (IV) across the HFSLM system is shown in **Fig.4.1**. Platinum (IV) in the feed solution diffuses to the interface of the feed - liquid membrane phases. Then, platinum (IV) reacts with Aliquat 336 at this interface to generate complex species as demonstrated in Eq. (1). After that, the complex species transport to the interface of the liquid membrane-stripping phases, using the concentration gradient. No transport of platinum (IV) across the liquid membrane is assumed. This complex species react with the stripping agents at the interface of the liquid membrane-stripping phases. Thus, the complex species are released into the stripping phase as revealed in Eq. (2). Platinum (IV) is transferred into the stripping phase while Aliquat 336 returns to the liquid membrane and transfers to the interface of feed and liquid-membrane. Aliquat 336 reacts again with platinum (IV) at this interface.

The extraction reaction of platinum (IV) using Aliquat 336 as the extractant has been published previously [31]. The extraction reaction of platinum (IV) in chloride media with Aliquat 336 is as follows:

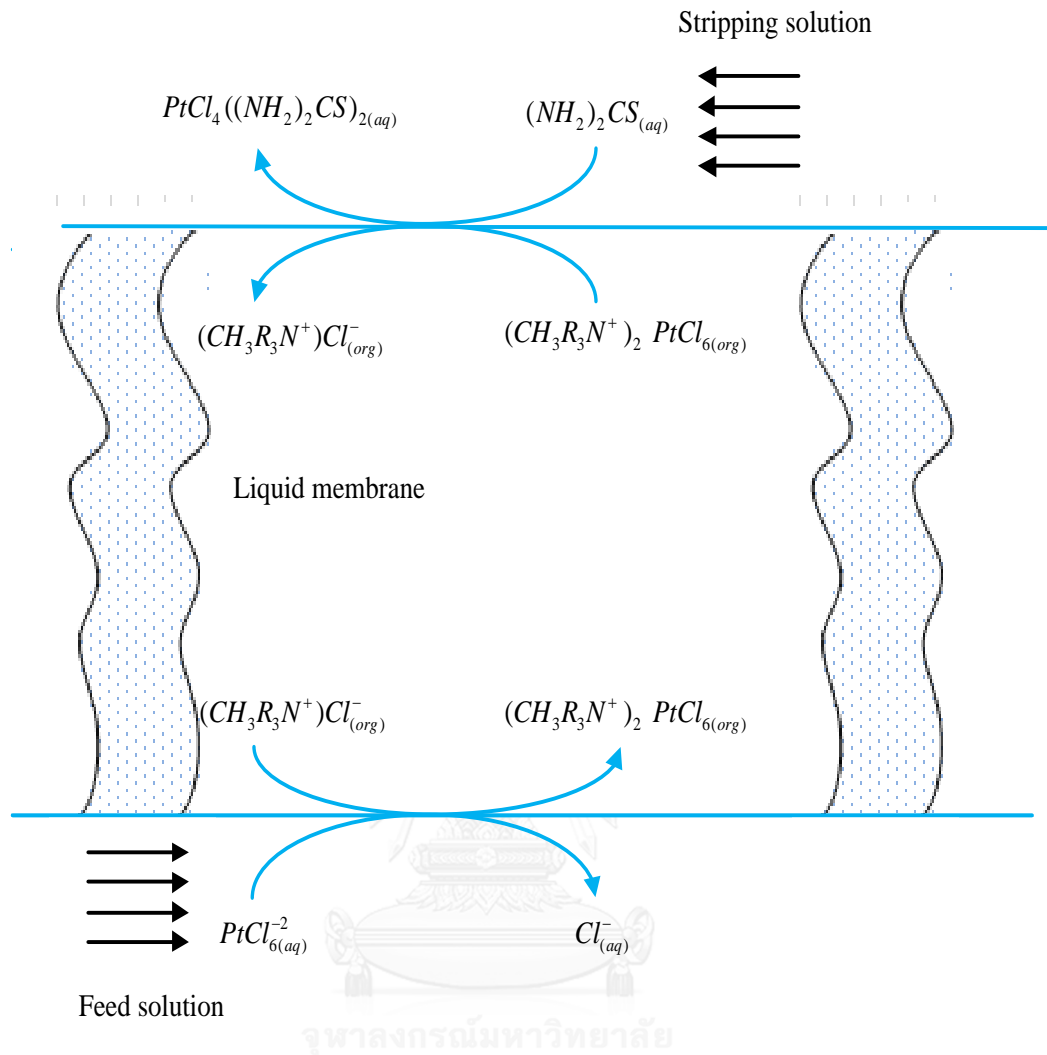


where  $PtCl_{6(aq)}^{-2}$  is platinum (IV) in the feed solution,  $(CH_3R_3N^+)Cl_{(org)}^-$  (Aliquat 336) is the selected extractant in the liquid-membrane phase,  $(CH_3R_3N^+)_2 PtCl_{6(org)}$  is the complex species in the liquid – membrane phase and  $Cl_{(aq)}^-$  is chloride ions.

The stripping of platinum (IV) with thiourea solution has been reported elsewhere [1]. The stripping reaction between the complex species and the stripping solution is as follows:



where  $(NH_2)_2CS_{(aq)}$  is the employed stripping agent in the stripping solution,  $PtCl_4((NH_2)_2CS)_{2(aq)}$  is platinum (IV) which was stripped from the liquid membrane.



**Fig.4. 1** Transportation of platinum (IV) across hollow fiber supported liquid membrane.

#### 4.3.2 Distribution ratio

The distribution ratio of platinum (IV) between the feed phase as well as the liquid- membrane phase can be determined by:

$$D = \frac{[(CH_3R_3N^+)_2PtCl_{6(org)}]}{[PtCl_{6(aq)}^{-2}]} \quad (4.3)$$

where  $[(CH_3R_3N^+)_2 PtCl_{6(org)}]$  is calculated by using Eq. (4.4), describing the partition equilibrium of platinum (IV) of the HFSLM system.

$$[(CH_3R_3N^+)_2 PtCl_{6(org)}] = \frac{V_a}{V_o} [(PtCl_{6(aq)}^{2-})_{f,in} - (PtCl_{6(aq)}^{2-})_{f,out}] \quad (4.4)$$

where  $V_a$  is volume of the feed solution ( $cm^3$ ) and  $V_o$  is volume of the liquid membrane solution ( $cm^3$ ).

#### 4.3.3 Calculation of overall mass transfer resistance

Eq. (4.5) was employed to assess the overall mass transfer coefficient. The mass transfer coefficient for platinum (IV) through the HFSLM system is the sum of six individual mass transfer resistances. These are the mass transfer resistance in the feed phase  $R_a (1/k_a)$ , the liquid membrane resistance  $R_m (1/k_m)$ , shell-side resistance  $R_o (1/k_o)$ , stripping reaction resistance  $R_{as} (1/k_{as})$  and stripping side resistance  $R_s (1/k_s)$ . The correlation of six individual mass transfer resistances and individual mass transfer coefficient is shown in Eq(4.5-4.6) [32]:

$$R = R_a + R_e + R_m + R_o + R_s + R_{as} \quad (4.5)$$

Otherwise;

$$\frac{1}{K} = \frac{1}{k_a} + \frac{1}{k_e} + \frac{1}{D_f k_m} + \frac{1}{D_f k_o} + \frac{1}{D_s k_s} + \frac{1}{(D_s / k_s) k_{as}} \quad (4.6)$$

The mass transfer resistance of platinum (IV) across the stripping phase in Eq. (4.6) can be ignored because the stripping reaction is instantaneous [32, 33]:

$$\frac{1}{K} = \frac{1}{k_a} + \frac{1}{k_e} + \frac{1}{D_f k_m} + \frac{1}{D_f k_o} \quad (4.7)$$

The Lévêque equation was calculated by using the relationship of the Sherwood (*Sh*) and Schmidt correlations (*Sc*) [34]. The mass transfer coefficient of platinum (IV) in the aqueous feed phase can be determined:

$$Sh = 1.62 \left( \frac{d_i}{L} Re Sc \right)^{0.33} \quad (4.8)$$

where *Re*, *Sh* and *Sc* can be defined as follows:

$$Re = \frac{4Q_f}{\mu \pi d_i}$$

$$Sh = \frac{K_f d_i}{D_f}$$

$$Sc = \frac{\nu}{D_f}$$

The value of *Re* was calculated as 30.17 which was lower than 2,700, demonstrating that the laminar flow occurred inside the hollow fibers. Consequently, *k<sub>a</sub>* can be calculated as below [33]:



$$k_a = 1.62 \frac{D_f}{d_i} \left( \frac{d_i v_f}{LD_f} \right)^{0.33} \quad (4.9)$$

The values of  $k_m$  can be determined as follows:

$$k_m = \frac{D_m \varepsilon d_{lm}}{\delta \eta d_o} \quad (4.10)$$

The values of  $k_o$  can be calculated using the correlation of the Sherwood and Schmidt correlation [33]:

$$k_o = 1.25 \frac{D_m}{d_h^{0.07}} \left( \frac{d_h v_s}{\nu L} \right)^{0.93} \left( \frac{\nu_s}{D_m} \right)^{0.33} \quad (4.11)$$

The hydraulic diameter between the shell sides of two fibers is determined as follows [23, 35]:

$$d_h = \frac{d_a^2 - d_i^2 - nd_0^2}{nd_0} \quad (4.12)$$

where  $d_h$  is the hydraulic diameter of the shell side (cm),  $d_i$  is the inner diameter of the shell side (cm) and  $d_o$  is the outer diameter of the membrane (cm).

#### 4.3.4 Experimental design for RSM

RSM has been utilized to determine optimized values of independent variables that maximize or minimize response (independent) variables. Among many designs, the commonest design in RSM is central composite design (CCD). In this work, face-centered central composite design (CCF) was selected in order to optimize the process parameters for extraction of platinum (IV) across the HFSLM system. A three-factor and three-level CCD with 17 individual design points was used to find the regression model. This is because CCF is able to relatively predict high quality over the entire design space [27]. CCF for three variables  $X_1$ (concentration of platinum (IV)),  $X_2$ (concentration of Aliquat 336) and  $X_3$ (concentration of  $\text{NH}_2\text{CSNH}_2$  in HCl) with three levels is listed in **Table 4.2**. The code of variables considered in this investigation is also presented in **Table 4.2**. The average percentage after three runs was taken as the response variable (% extraction of platinum (IV)).

A second-order polynomial regression equation according to Eq(4.13) was estimated from the experiment utilizing the degree of platinum (IV) extraction:

$$Y = \beta_0 + \sum_{i=1}^3 \beta_i X_i + \sum_{i=1}^3 \beta_{ii} X_i^2 + \sum_{i < j=1}^3 \beta_{ij} X_i X_j \quad (4.13)$$

where  $Y$  is the response variable (% extraction of metal ions),  $\beta_0$ ,  $\beta_i$ ,  $\beta_{ii}$  and  $\beta_{ij}$  represent the regression coefficients of intercept, linear, quadratic, and interaction terms, respectively, and  $X_i$ ,  $X_j$  are the independent variables.

In this work, the design of the experiment and the analysis of variance (ANOVA) of the CCF design was conducted employing Design-Expert software using version 9.0.6 (the Design-Expert® software trial).

**Table 4. 2** Level and code of variables for Box-Behnken design.

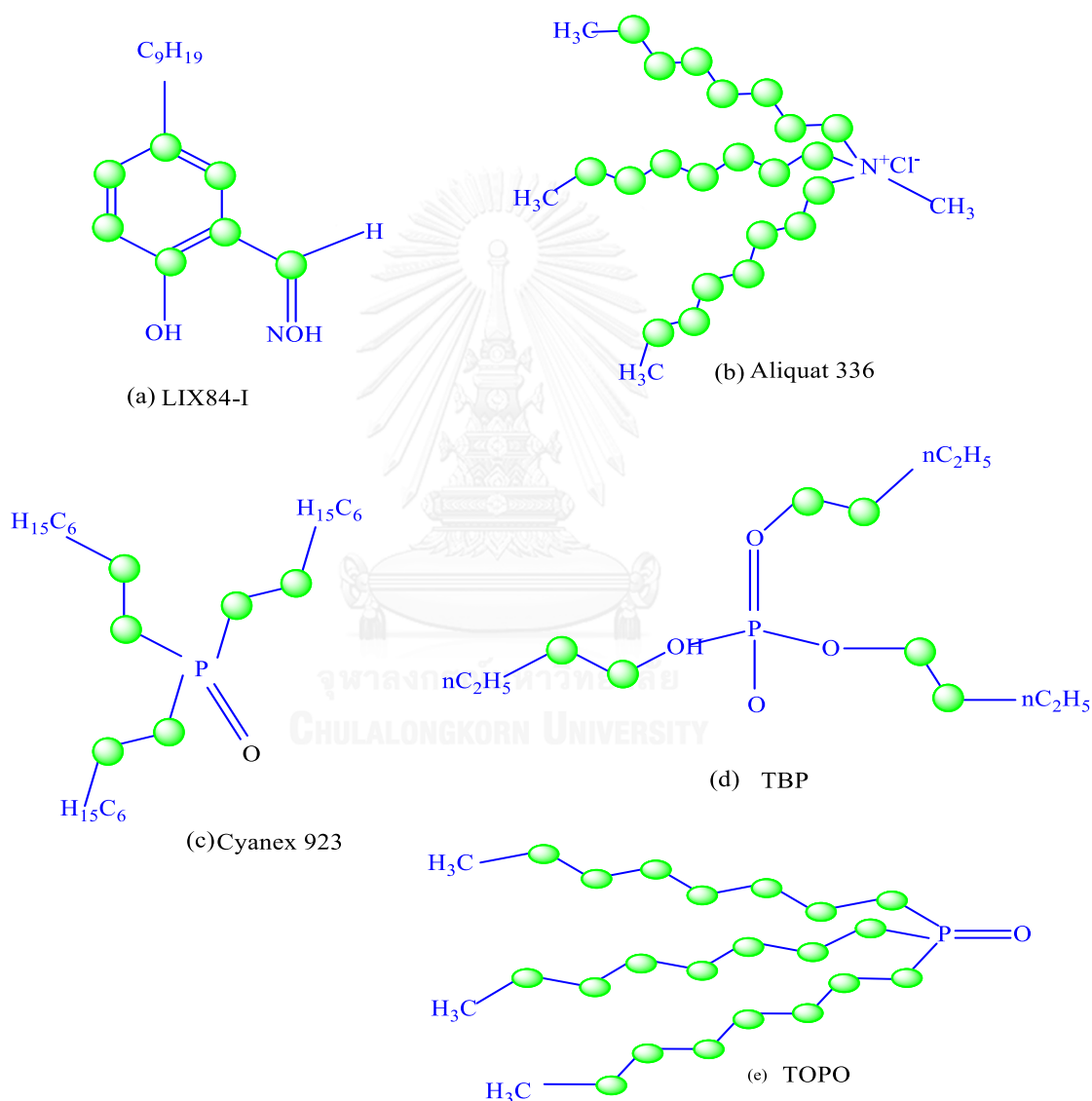
Variables	Symbol	Coded levels		
		-1	0	+1
Platinum(IV), (mg/L)	$X_1$	5	30	50
Aliquat 336, %(v/v)	$X_2$	3	7	10
Thiourea, M	$X_3$	0.1	0.8	1

## 4.4 Experiment

### 4.4.1 Chemicals and reagents

Platinum (IV) solutions were prepared by dissolving an appropriate quantity of platinum (IV) chloride in 5 M hydrochloric acid. Platinum (IV) concentration in the aqueous solutions was measured by the inductively coupled plasma optical emission spectrometer (ICP–OES). The liquid membrane was impregnated with different extractants in the micro-porous hollow fibers as listed in **Table 4.3**. The structures of these extractants are shown below in **Fig.4.2**.  $\text{NH}_2\text{CSNH}_2$  (98% purity) and HCl (37% purity) was used as stripping agents. Hydrochloric acid (Sigma-Aldrich) and

sodium hydroxide (97% purity from Sigma-Aldrich) were employed to adjust the value of pH in feed solutions. All reagents used throughout experiments were of analytical grades. Double distilled water ( $18.2 \text{ M}\Omega\cdot\text{cm}^{-1}$ ) was employed throughout the experiments.



**Fig.4. 2** Chemical structures of (a) LIX84-I (b) Aliquat 336 (c) Cyanex 923 (d) TBP and (e) TOPO.

**Table 4. 3** Extractants and stripping agents used in this study.

<b>Extractants/stripping agents</b>	<b>Reagent name</b>	<b>MW</b> g/mol	<b>Density</b> g/cm <sup>3</sup>	<b>Company</b>	
Aliquat 336	N-Methyl-N,N,N-trioctylammonium chloride	404	0.884	Sigma-Aldrich	
LIX84-I	2-hydroxy-5-nonylacetophenone oxime	263	0.940	Henkel	Thai Ltd
Cyanex 923	Phosphine oxides	348	0.880	Henkel	Thai Ltd.
TBP	Tri-n-butyl phosphate	266	0.973	Sigma-Aldrich	
TOPO	Trioctylphosphine oxide	387	0.880	Sigma-Aldrich	
NH <sub>2</sub> CSNH <sub>2</sub>	Thiourea	76.12	-	Sigma-Aldrich	
HCl	Hydrochloric acid	36.46		Sigma-Aldrich	

The best conditions from using the synthetic wastewater were observed and used in order to compare with the industrial wastewater from gold refining processes, kindly supplied by Gold Field Refinery Co. Ltd, Thailand. The composition of the gold refining wastewater is shown in **Table 4.4**.

**Table 4. 4** Compositions of gold refining wastewater.

Metals	Pt(IV)	Pd(II)	Au(III)	Cu(II)	Zn(II)
Concentration (mg/L)	5.00	0.88	0.94	0.55	0.12

#### 4.4.2 Apparatus

The HFSLM equipment used for carrying out the separation of platinum (IV) is comprised of a hollow fiber module, gear pumps, rotameters, variable flow rate controllers and pressure gauges. The hollow fiber module is composed of Celgard®x-40 microporous fibres intertwined into the fabric and wrapped around a central-tube feeder to supply the shell-side fluid. Physical characteristics of this module are shown below in **Table 4.5**. The feed and stripping solutions were stirred by using a magnetic stirrer (model CMT-V1; Protronics Intertrade Co., Ltd., Thailand). The professional pH Meter PP-50 (TransInstruments, Singapore) was used to measure the pH values of the feed solution by using hydrochloric acidic solution and sodium hydroxide solution to adjust the pH of the feed solution. A peristaltic pump from Cole-Parmer, USA with 8.6 bar (125 psi) was used throughout experiments. The inductively coupled plasma optical emission spectrometer (ICP-OES) (model JY 2000-2; HORIBA Jobin Yvon, France) was employed to measure the concentration of platinum (IV) in the feed and stripping samples.

**Table 4. 5** Properties of the hollow fiber module.

Characteristics	Descriptions
Material	polypropylene
Number of fibers	35,000
Fiber inside diameter	0.024 cm
Fiber outside diameter	0.03 cm
Effective length	19.8 cm
Surface area	$1.4 \times 10^4 \text{ cm}^2$
Area per unit volume	$29.3 \text{ cm}^2/\text{cm}^3$
Membrane porosity	30%
Average pore size	$3 \times 10^{-6} \text{ cm}$
Membrane tortuosity	2.6
Module diameter	6.3 cm
Module length	20.3 cm
Operating temperature	273 – 333 K

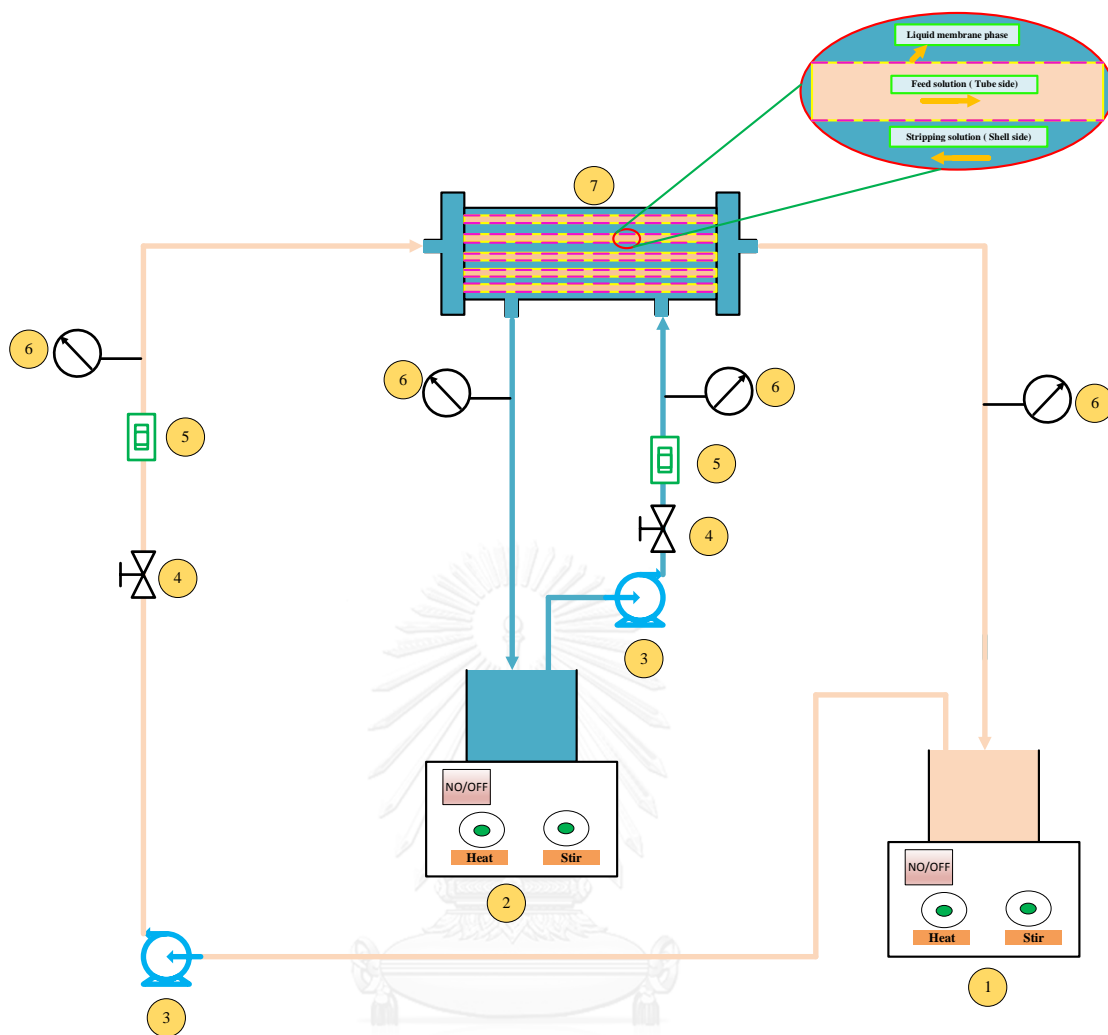
#### 4.4.3 Procedures

The liquid-membrane was prepared by circulating extractants (such as Aliquat 336, LIX84-I, cyanex 923, TBP and TOPO) dissolved in kerosene into the tube and shell sides of the hollow fiber module. The circulated time was 40 min in order to ensure the extractant wholly embedded in the micro-pores of the hollow fibers [36]. Circulating time for impregnation of Aliquat 336 in the liquid - membrane was assessed by adjusting the time ranging from 30-80 min and it was found that the efficiency of extraction of platinum (IV) was not significantly different. Thus, the

time of 40 min was set in all experiments. Distilled water was used to wash out the excessive liquid membrane for 10 min. Subsequently, both feed and stripping solutions were pumped into the HFSLM system. Samples of outlet feed and stripping for each experimental condition were kept after 30 min. Operating temperature was at ambient temperature (30 °C). The experimental operation was set up as shown in **Fig.4.3**. After finishing each run, the hollow fiber module was regenerated for a new separation cycle. Surfactant and distilled water was used in order to eliminate the liquid membrane in the micro-pores of the hollow fibers. Subsequently, the hollow fibers were dried with isopropyl alcohol. The concentration of metal ions in the aqueous phases was determined before and after extraction for calculating the efficiency of extraction and stripping. The concentration of metal ions in the liquid-membrane phases was deduced by mass balance. In order to confirm the efficiency and reliability, each analysis was conducted in three duplicate. The pH of feed solution was maintained at 2. The mixtures of 0.8 M thiourea and 1 M HCl were employed as the stripping solution. This data have been reported in previous works [37, 38] as listed in **Table 4.6**.

The mass transfer resistance in the feed phase  $k_a$ , the liquid membrane resistance  $k_m$ , shell-side resistance  $k_o$  and overall mass transfer resistance are calculated by using the correlations from Eq(4.5) to Eq(4.12) as reported elsewhere [32, 33].





**Fig.4. 3** Schematic representation of the flow diagram of feed and stripping solutions in counter-current direction via HFSLM: (1) feed reservoir (2) stripping solution reservoir (3) pump (4) flow regulator valve (5) flow indicator (6) pressure indicator and (7) HFSLM.

**Table 4. 6** Optimized conditions for operation of HFSLM for separation of platinum (IV)

Conditions	Optimized Values
Concentration of platinum(IV), mg/L	5
pH in feed solution	2
Aliquat 336, %(v/v)	10
Impregnated time of liquid membrane, min	40
Operating time, min	30
Diluents	kerosene
Flow rate in the feed solution, mL/min	100
Flow rate in the stripping solution, mL/min	100

จุฬาลงกรณ์มหาวิทยาลัย  
CHULALONGKORN UNIVERSITY

The accuracy of the modeling was verified by the standard deviation as follows [39]:

$$S.D.(%) = 100 \times \sqrt{(n_{data} - 1)^{-1} \times \sum_{i=1}^{n_{data}} \left[ \frac{(C_{i,cal} - C_{i,exp})}{C_{i,exp}} \right]^2} \quad (4.14)$$

where  $n_{\text{data}}$  is the number of data points and the superscripts “cal” and “exp” refer to the calculated and experimental values, respectively.  $C_{\text{exp}}$  and  $C_{\text{cal}}$  in mg/L are concentrations obtained from the experiment and the model.

## 4.5. Results and discussion

### 4.5.1 The influences of types and concentration of extractants

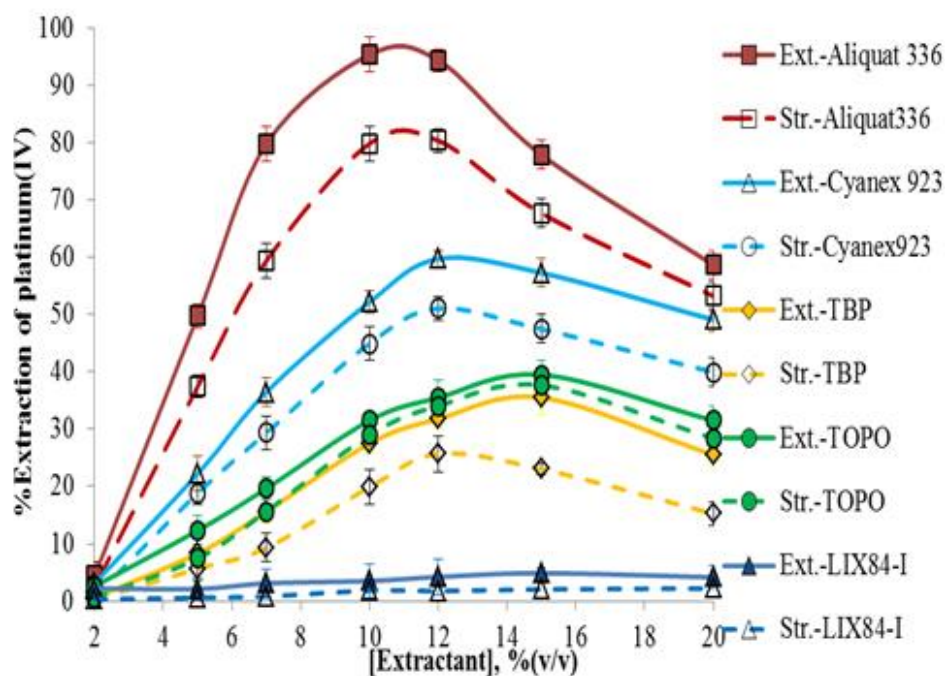
Aliquat 336, LIX84, Cyanex 923, TBP and TOPO, dissolved in kerosene were selected as the liquid membrane. Aliquat 336 was selected because Aliquat 336 is a water insoluble quaternary ammonium salt produced by the methylation of mixed trioctyl/ decyl amine, which is capable of forming oil soluble salts of anionic species at acidic or slightly alkaline pH. It is composed of a large organic cation associated with a chloride ion,  $(CH_3R_3N^+)Cl_{(org)}^-$ . As the ammonium structure has a permanent positive charge, it can form salts with anions over a wider pH range than primary, secondary or tertiary amines. Other extractants were selected because its performance on the separation of the precious metals in different systems [37, 38, 40, 41].

Five extractants were tested via HFSLM, operated by using a single module operation. **Fig. 4.4** depicts types of extractants as a function of their concentration by plotting percentage extraction of platinum (IV) versus concentration of extractants investigated. It was observed that the order of extraction power was in the sequence of Aliquat 336 > Cyanex 923 > TOPO > TBP > LIX84. Aliquat 336 showed the best performance greater than other extractants investigated. This was attributed to the fact that Aliquat 336 is a basic extractant which reacts well with anions of platinum (IV)

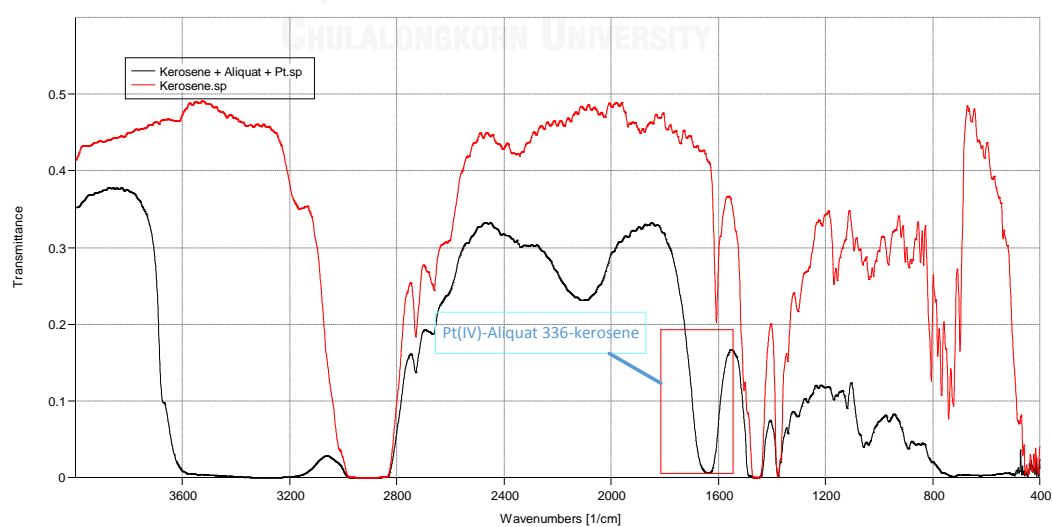
[42]. Furthermore, Aliquat 336 was found to be most effective in the extraction and stripping of other metal ions, namely plutonium [43] and chromium [44].

FT-IR was operated to characterize platinum (IV) complex after extraction. The result is illustrated in **Fig. 4.5** demonstrating the location where the platinum (IV) complex formed after the  $(\text{CH}_3)\text{N}^+$  function group in Aliquat 336 captured the platinum (IV) in stretching pattern.

According to Eq. (4.1), the percentages of extraction of platinum (IV) are positively influenced by the concentration of extractants investigated. The concentration of Aliquat 336 was varied in the range of 2-20 % (v/v). In the case of LIX84, Cyanex 923, TBP, TOPO, experiments were carried out similar to Aliquat 336. The experimental results are presented in **Fig. 4.4**. Thus, it was noted that percentages of extraction of platinum (IV) increased in the case of all extractants studied. However, when the concentration of all extractants increased more than 12 % (v/v), percentages of extraction of platinum(IV) decreased. This may be attributed to an increase in the viscosity of the liquid membrane phase which may retard the mass transfer rates [36, 45]. Thus, 10 % (v/v) Aliquat 336 was employed in further experiments.



**Fig.4. 4** The influence of types of extractants and their concentration on percentages of extraction platinum (IV) under pH 2 of feed solution, 0.8 M  $\text{NH}_2\text{CSNH}_2$  in 1 M HCl, 100 mL/min equal flow rates of feed and stripping.



**Fig.4. 5** FT-IR spectrum of complex species in the liquid membrane phase (Pt(IV)-Aliquat 336-kerosene)

#### 4.5.2 The influences of extractants on distribution ratio and permeability coefficient

The distribution coefficients (D) of platinum (IV) from aqueous solution through HFSLM as reported in **Table 4.7**, were determined. It was noted that the distribution coefficient depends on the concentration of each extractant in the liquid-membrane phase. Regarding Aliquat 336, the distribution coefficient increased when Aliquat 336 concentration increased until it reached an optimum point of 10 %(v/v). However, it decreased at Aliquat 336 concentration greater than 12%(v/v). This was due to an increase in viscosity of Aliquat 336 which led to an increase in liquid membrane resistance and difficulty in transport of the platinum (IV)-extractant complex [46]. The results demonstrate that Aliquat336 concentration should not exceed 10%(v/v).

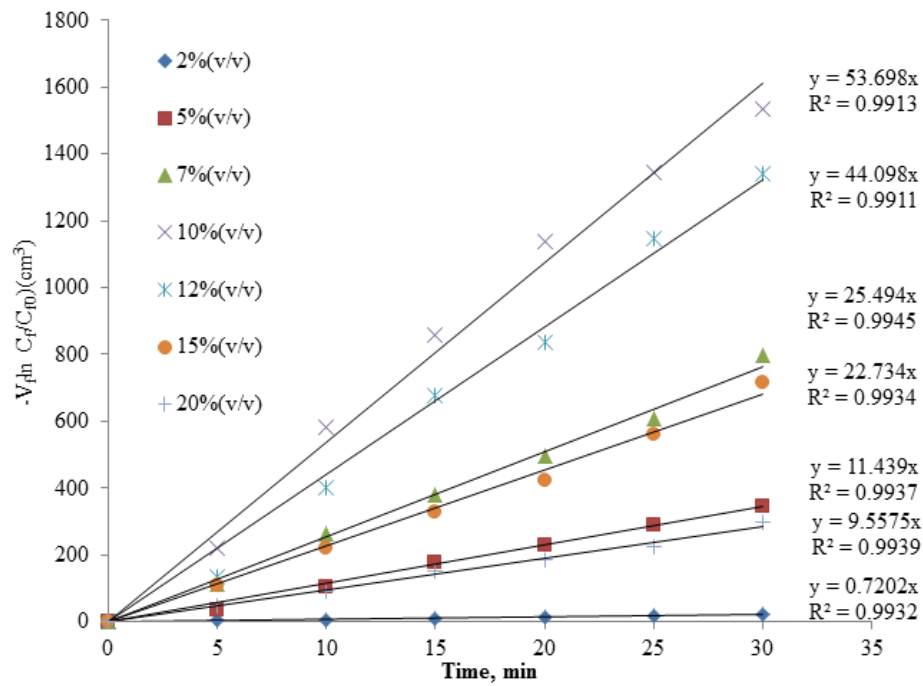
The permeability coefficient can be explained as reported by Danesi et al. [47]:

$$-V_{feed} \ln \frac{C_{feed}}{C_{feed,0}} = AP \frac{\alpha}{\alpha + 1} t \quad (15)$$

where 
$$\alpha = \frac{Q_{feed}}{PLE\pi Nr_i}$$

$V_{feed}$  stands for the volume in the feed solution,  $C_{feed, 0}$  and  $C_{feed}$  stand for the platinum(IV) concentrations at time 0 and t, respectively,  $A$  is the area of the hollow fiber module,  $P$  is the permeability coefficient,  $t$  is the time,  $Q_{feed}$  is the flow rate in the feed solution,  $L$  is the length,  $\varepsilon$  is the hollow fiber porosity,  $N$  is the number of hollow fibers in the module, and  $r_i$  is the internal radius of the hollow fiber. In Eq. (4.15), the slope in terms of  $AP(\alpha/\alpha+1)$  was obtained by plotting  $[-V_{feed} \ln$

$(C_{feed}/C_{feed,0})]$  versus time ( $t$ ). The results are illustrated in **Fig. 4.6**. Finally, the values of  $P$  can be determined as shown in **Table 4.7**. The results indicate that  $P$  decreased when the concentration of extractants increased.



**Fig.4. 6** Permeability coefficient versus operating time under concentration of extractants ranging from 3-15 % (v/v), pH 2 of feed solution, 0.8 M  $\text{NH}_2\text{CSNH}_2$  in 1 M HCl, 100 mL/min equal flow rates of feed and stripping.

**Table 4. 7** Efficiency of HFSLM in terms of distribution ratios and permeability coefficients using different extractants under optimal conditions.

Extractants, %(v/v)	D (-)	P(cm/s) x 10 <sup>4</sup>	Extractants, %(v/v)	D(-)	P(cm/s) x 10 <sup>4</sup>
LIX84-I			TOPO		
2	0.002	0.100	2	0.026	0.369
5	0.003	0.114	5	0.123	0.970
7	0.011	0.119	7	0.196	1.266
10	0.035	0.439	10	0.315	1.592
12	0.042	0.458	12	0.355	1.721
15	0.029	0.325	15	0.395	1.772
20	0.022	0.263	20	0.315	1.546
Cyanex 923			Aliquat 336		
2	0.031	0.317	2	0.044	0.441
5	0.222	1.513	5	0.498	1.928
7	0.365	1.721	7	0.798	2.197
10	0.522	1.977	10	0.953	2.324
12	0.597	1.985	12	0.943	2.321
15	0.573	1.913	15	0.779	2.182
20	0.491	1.899	20	0.587	1.884
TBP					
2	0.006	0.106			
5	0.083	0.735			
7	0.156	1.138			
10	0.275	2.082			
12	0.318	1.450			
15	0.355	1.570			
20	0.255	1.350			



### 4.5.3 The effect of extractants on mass transport resistance

The mass transfer resistances were determined under optimized conditions such as pH 2 of feed solution, Aliquat 336 at 10%(v/v) dissolved in kerosene, 0.8 M  $\text{NH}_2\text{CSNH}_2$  and 1 M HCl and 100 mL/ min equal flow rates of feed and stripping solution. The mass transfer resistance in the feed phase  $k_a$ , the liquid membrane resistance  $k_m$ , shell-side resistance  $k_o$  and overall mass transfer resistance were calculated by using the correlations from Eq(4.5) to Eq(4.12) as reported elsewhere [32, 33]. The four individual transfer resistances are listed in **Table 4.8**.  $1/K$  was determined and found to be  $6.865 \times 10^4$  s/cm. The mass transfer resistances from the liquid membrane phase proved to be much higher than that from the extraction reaction and the shell side mass transfer resistances. This demonstrated that the mass transfer resistance from the feed phase and the shell side mass transfer resistances had less influence on the overall mass transfer process. Individual transfer resistances of Cyanex 923, TOPO, TBP, and LIX84 are also listed in **Table 4.8**. The transportation of platinum (IV) across the liquid membrane in the case of using Cyanex 923, TOPO, TBP, and LIX84 was controlled by the mass transfer resistance from the liquid membrane

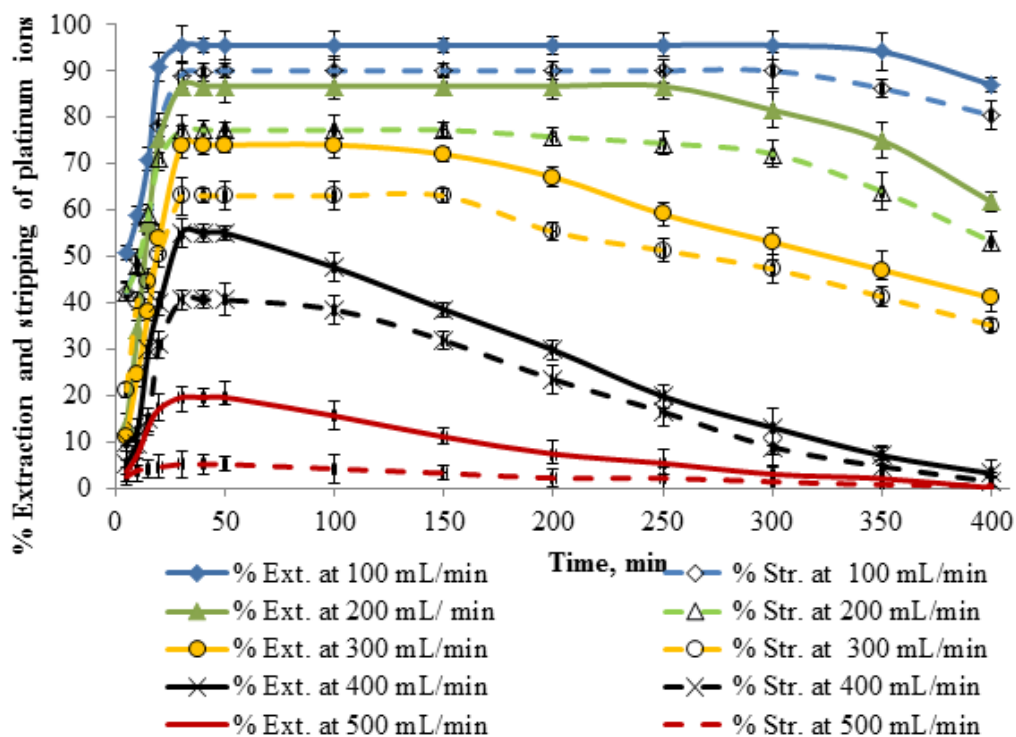
**Table 4. 8** Mass transfer resistances under optimum conditions.

Extractants	Individual mass transfer resistances x 10 <sup>-4</sup> s/cm			
	1/ <i>k<sub>a</sub></i>	1/ <i>k<sub>m</sub></i>	1/ <i>k<sub>o</sub></i>	<i>I/K</i>
Aliquat 336	3.297	0.164	3.406	6.865
Cyanex 923	3.297	0.0071	3.406	6.710
TOPO	3.297	0.0066	3.406	6.710
TBP	3.297	0.0081	3.406	6.711
LIX84	3.297	0.0075	3.406	6.711

**Note:** pH 2 of feed solution, 10%(v/v) Aliquat 336 dissolved in kerosene, 0.8 M NH<sub>2</sub>CSNH<sub>2</sub> and 1 M HCl as the stripping agent, room temperature, and equal flow rates of feed and stripping solution at 100 mL/ min.

#### 4.5.4 Effects of flow rates of feed solution $Q_f$ and stripping solution $Q_s$

The influence of  $Q_f$  and  $Q_s$  on the separation of platinum (IV) was varied in the range of 100– 500 mL/min in one module operation. The result is shown in **Fig. 4.7**. Maximum percentages of extraction of platinum (IV) were obtained for both  $Q_f$  and  $Q_s$  at 100 mL/min. Percentages of platinum (IV) extraction obtained were 96%. However, percentages of platinum (IV) extraction decreased when the values of  $Q_f$  and  $Q_s$  increased owing to the residence time of the solution in the hollow fiber module as well as the loss of liquid-membrane from the micro-pores of the hollow fibers which occurred [48].



**Fig.4.** Percentages of extraction of platinum (IV) versus the flow rate of feed and stripping solution between 100 and 500 mL/min under pH 2 of feed solution, 0.8 M  $\text{NH}_2\text{CSNH}_2$  in 1 M HCl and 100 mL/min equal flow rates of feed and stripping.

#### 4.5.5 Separation of platinum (IV) from industrial wastewater

The selectivity was controlled by adjusting the types of extractants, stripping agent and pH of feed solution [49, 50]. In this study, the formation of target ions in feed solution is formed in different forms at pH 2. Platinum (IV) and palladium (II) are in form of  $\text{PtCl}_6^{2-}$  and  $\text{PdCl}_4^{2-}$ , respectively. Aliquat 336 which composed of a

large organic cation associated with a chloride ion,  $(CH_3R_3N^+)Cl_{(org)}^-$ , can extract both  $PtCl_6^{-2}$  and  $PdCl_4^{-2}$  [37, 38]. However,  $PdCl_4^{-2}$  is lower stripped from the liquid membrane as shown in **Fig. 4.8**. Like, the effect of 2-ethylhexyl-2-ethylhexyl phosphoric acid (HEHEPA) on the extraction and stripping of Nd(III) from other rare earth metals [51].

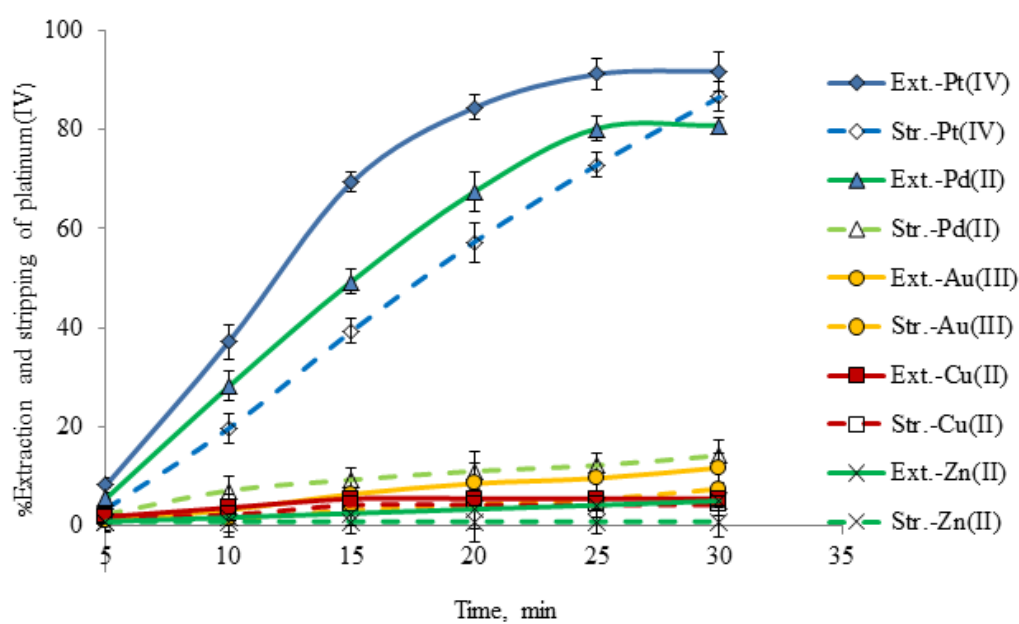
Some vital extraction conditions were optimized and the HFSLM method was applied to actual wastewater samples from gold refining processes, kindly supplied by Gold Field Refinery Co. Ltd, Thailand. Thus, it was observed that extraction of platinum (IV) from gold refining wastewater via HFSLM reached 90% as shown in **Fig.4.8**. However, when the industrial wastewater was compared with the synthesis wastewater, efficiency of extraction of platinum (IV) dropped 5.2%. This was because of the influence of other impurities (other metal ions) [52]. The trend of extraction of other impurities was observed as follows: Pt(IV)>Pd(II)>Au(III)>Cu(II)>Zn(II).

The efficiency of selective separation of platinum (IV) from other metal ions in terms of separation factor [53, 54], is reported in **Table 4.9**. The separation factor is shown in Eq(16):

$$S.F. = \frac{D_{Pt(IV)}}{D_M} \quad (4.16)$$

where  $D_{Pt(IV)}$  = distribution coefficient of platinum(IV),  $D_M$  = distribution coefficient of Pd(II), Au(III), Cu(II) and Zn(II).

This indicated that a small amount of impurities was transported within the time interval required for quantitative transport of platinum (IV). Therefore, platinum (IV) can be selectively extracted and stripped from gold refining wastewater using Aliquat 336.



**Fig.4. 8** The extraction and stripping of platinum(IV) and their impurity from gold refining wastewater under: pH 2 of feed solution, 10%(v/v) Aliquat 336, 0.8 M  $\text{NH}_2\text{CSNH}_2$  and 1 M HCl and equal flow rates of feed and stripping solution at 100 mL/ min.

**Table 4.9** The separation factor for validation at 10%(v/v) Aliquat 336.

SF <sub>A/B</sub>	Pt(IV)/Pd(II)	Pt(IV)/ Au(III)	Pt(IV)/ Cu(II)	Pt(IV)/ Zn(II)
Values	16.97	248.68	969.49	1275.84

#### 4.5.6 Optimization of extraction of platinum (IV)

A Box-Behnken design under RSM was employed to analyze the interactive influence of feed concentration, concentration of Aliquat 336 and concentration of the mixture of NH<sub>2</sub>CSNH<sub>2</sub> and HCl. The variables in coded units for the design matrix are shown in **Table 4.2**. **Table 4.10** below shows the predicted results and the experimental data of response (percentages of extraction of platinum (IV), % E). The predicted results of responses (%E) were obtained from quadratic model fitting techniques employing the software. Multiple regression analysis of the experimental data was applied to develop the statistical model in order to predict the percentages of the extraction of platinum (IV). The statistical model is presented accordingly:

$$\begin{aligned} \% E = & 47.64333 - 0.71130X_1 + 13.84382X_2 - 22.03835X_3 + 0.063903X_1X_2 \\ & - 0.014118X_1X_3 - 0.89898X_2X_3 + 3.48136 \times 10^{-3} X_1^2 - 1.30890X_2^2 - 0.67151X_3^2 \end{aligned} \quad (4.17)$$

where %E (yield) is the percentages of extraction of platinum (IV),  $X_1$  is concentration of platinum (IV) in feed solution, mg/L,  $X_2$  is the concentration of Aliquat 336 in the liquid membrane and  $X_3$  is the concentration of thiourea in stripping solution.

The statistical model was verified by employing variance (ANOVA) for the response surface quadratic model [55, 56]. As can be seen in **Table 4.11**, the F-value of the model is 52.23 indicating that the model is highly significant [57]. The model has a very low probability value (p model,  $F < 0.0002$ ). Values of p are less than 0.0500 which demonstrate that the model terms are significant [58, 59]. All the model coefficients such as  $X_1$ ,  $X_2$ ,  $X_3$ ,  $X_1X_2$ ,  $X_1X_3$ ,  $X_2X_3$ ,  $X_1^2$ ,  $X_2^2$  and  $X_3^2$  are significant as shown in **Table 4.11**. The accuracy of this model can be verified by determining the adjusted  $R^2$  (multiple correlation coefficients  $R$ ). The value of adjusted  $R^2$  (0.9853) for Eq. (4.17) indicates that the total variation of 98.53% for percentages of extraction of platinum (IV) is attributed to the independent variables and only about 1.47% of the total variation cannot be expressed by using this model. The closer the values of adjusted  $R^2$  are equal to 1 indicate that correlation between the experimental and predicted values fit in well [60]. Moreover, the sum of squared errors of prediction (SSE) and the corresponding root-mean square deviation (RMSD) were 5.2514 and 0.1164. Low of SSE and RMSD proved that the results from predicted model were in good agreement with experimental data.

In **Fig. 4.9(a)** below, the normal probability plot of residuals for extraction of platinum (IV) indicates how closely the set of obtained values followed the theoretical distribution. In **Fig.4.9(b)**, experimental points are reasonably aligned, suggesting a normal distribution. Thus, the developed regression model adequately describes the data obtained, approximately expressing 98.53% of the variability of response. Moreover, the use of residuals was investigated to access the model adequacy. In **Fig.**

**4.9(c)**, residuals were found to be scattered and without any definite pattern which showed the adequacy of the model.

A Design Expert program was employed to plot the fitted response surface in order to understand the interaction of the parameters required for optimum condition for extraction of platinum (IV). The plots are illustrated in **Figs 4.10(a-c)**. According to Fig. 10(a1 and a2), the response surface plots show the relation among the concentration of Aliquat 336 in the liquid membrane and the concentration of thiourea, while the concentration of HCl were kept constant at 1 M.. The increase in the concentration of Aliquat 336 improved percentages of extraction of platinum (IV) because the higher available Aliquat 336 reacting with platinum (IV) at the interface of feed and stripping solution. At higher amounts of concentration of Aliquat 336, the percentage of extraction significantly decreased because of the limited mass transfer rate of target ions across the liquid membrane phase.

**Fig. 4.10(b1)** and **4.10(b2)** shows the interaction of the concentration of Aliquat 336 with the concentration of platinum (IV) and their relation to the percentage of extraction. Maximum extraction of platinum (IV) is achieved with 10%(v/v) Aliquat 336. The results show that at higher concentration of platinum(IV), the percentages of extraction is low because of the high amount of platinum(IV) accumulating at the interface of feed and liquid membrane phase, resulting in fouling. The fouling causes to obstruct the transportation of complex species across the liquid membrane phase.

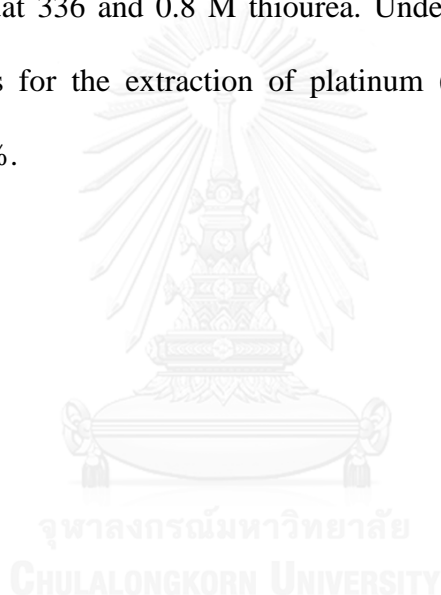
**Fig. 4.10(c1)** and **4.10(c2)** illustrated the interaction of the concentration of platinum(IV) in the feed solution and concentration of thiourea by fixed the concentration of hydrochloric acid at 1 M. Maximum extraction of platinum (IV) is



achieved using the concentration of thiourea higher 0.8 M and all concentration of platinum(IV) investigated.

The results show that the initial adsorption rate is very rapid because of the high available surface area and vacant sites on the adsorbent, and the rate is accelerated by enhanced mass transfer promoted by the ultrasonic power.

By solving Eq. (4.16) using the above-mentioned software, the optimum conditions for the test variables were the concentration of feed solution 5 mg/L, 10% (v/v) Aliquat 336 and 0.8 M thiourea. Under these conditions, maximum predicted percentages for the extraction of platinum (IV) were observed reaching approximately 95.92%.

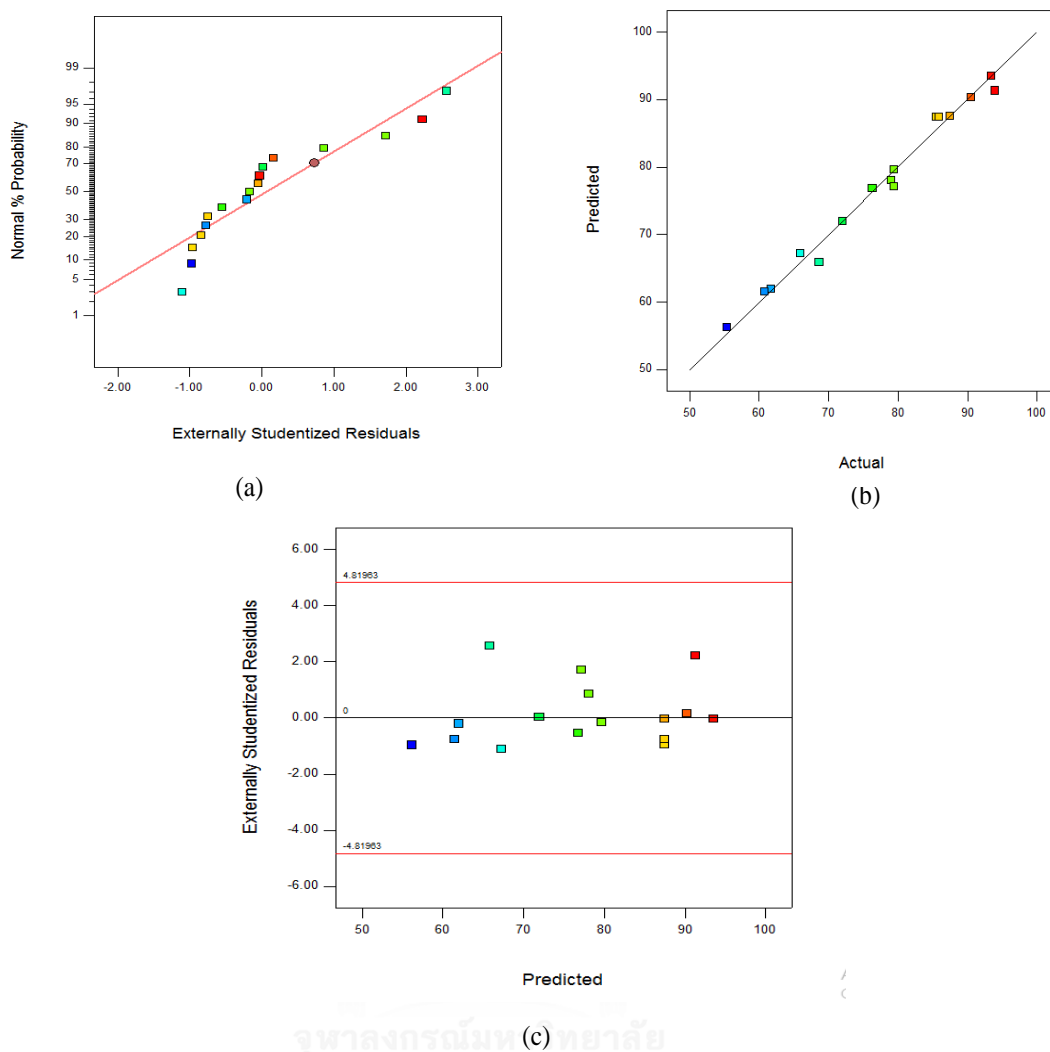


**Table 4. 10** Face-centred composite design matrix along with experimental and predicted values of platinum(IV) extraction across HFSLM.

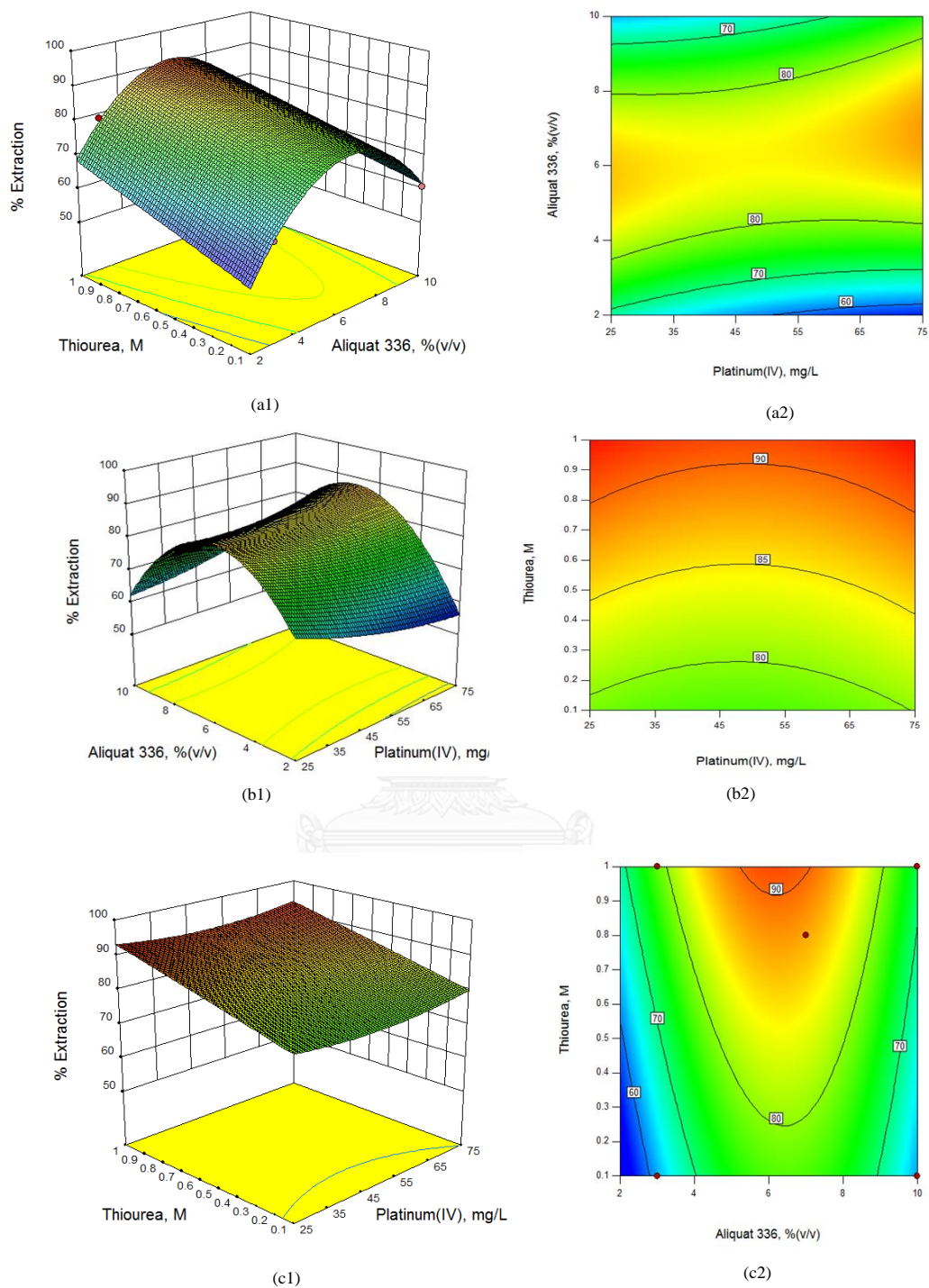
Experiment No.	Feed concentration (mg/L), $X_1$	Aliquat 336 concentration (%(v/v)), $X_2$	Stripping phase concentration (M), $X_3$	Extraction (%)	
				Experimental	Predicted (Eq.(16))
1	-1	-1	-1	76.32	76.8
2	-1	1	1	65.98	65.22
3	1	-1	1	79.07	78.08
4	1	1	-1	60.76	61.51
5	0	0	0	85.93	86.46
6	-1	-1	1	93.45	93.48
7	-1	1	-1	55.34	56.21
8	1	-1	-1	61.78	61.98
9	1	1	1	71.98	71.95
10	0	0	0	85.56	85.46
11	-1	0	0	95.92	95.29
12	1	0	0	87.45	87.52
13	0	-1	0	79.37	79.64
14	0	1	0	68.66	67.83
15	0	0	-1	79.45	79.15
16	0	0	1	90.54	90.28
17	0	0	0	85.76	86.46

**Table 4. 11** ANOVA for the response surface quadratic polynomial model.

Factors	Sum of square (SS)	df	Mean square (MS)	F-value	p
Model	2234.09	9	248.23	52.23	<0.0001
$X_1$	0.047	1	0.047	$9.867 \times 10^{-3}$	0.9237
$X_2$	35.24	1	35.24	7.42	0.0296
$X_3$	216.73	1	216.73	45.60	0.0003
$X_1X_2$	203.85	1	203.85	42.89	0.0003
$X_1X_3$	0.17	1	0.17	0.037	0.8537
$X_2X_3$	17.10	1	17.10	3.60	0.0997
$X_1^2$	8.09	1	8.09	1.70	0.2333
$X_2^2$	657.04	1	657.04	138.25	<0.0001
$X_3^2$	0.022	1	0.022	$4.6 \times 10^{-3}$	0.9478
Lack of fit	32.20	5	6.64	193.58	0.0051
Pure error	0.069	2	0.034		
Cor.total	2267.36	16			



**Fig.4. 9** (a) The normal probability plot for platinum extraction; (b) plot of observed values versus predicted values and (c) plot of residuals versus observed values.



**Fig.4. 10** (a1 and a2) is corresponding three-dimensional surface plot and contour plot of concentration of Aliquat 336 %(v/v) and platinum (IV) mg/L, (b1 and b2) is of thiourea M and platinum (IV) mg/L and (c1 and c2) is of Aliquat 336 %(v/v) and thiourea .

#### 4.6. Conclusion

Different commercial extractants such as Aliquat 336, LIX84-I, Cyanex 923, TBP and TOPO were investigated by dissolving in kerosene. Results indicated that Aliquat 336 is a more powerful extractant than LIX84, Cyanex 923, TBP and TOPO for given conditions. Extraction of platinum (IV) reached 96% when Aliquat 336 was used as extractant under optimized conditions. The mass transfer resistance for Aliquat 336 was investigated. It was found that the liquid membrane resistance ( $1/k_m$ ) of  $0.164 \times 10^4$  s/cm, aqueous solution in the feed phase resistance ( $1/k_a$ ) of  $3.297 \times 10^4$  s/cm, organic phase shell-side resistance ( $1/k_o$ ) of  $3.404 \times 10^4$  s/cm and overall mass transfer resistance ( $1/K$ ) of  $6.865 \times 10^4$  s/cm was obtained. Thus, it can be verified that the HFSLM system was governed by the mass transfer resistance from the liquid membrane. Experimental results, after three identical runs, were found to be excellent. Next, response surface methodology (RSM) was investigated in order to determine optimum values for the independent variables. Results showed that the HFSLM system could effectively separate platinum (IV) from gold refining solution. A quadratic regression model showed the interaction between independent parameters (concentrations of platinum (IV), Aliquat 336 and thiourea). The significant regression coefficient ( $p < 0.05$ ) proved that this model was an excellent goodness of fit with the experimental data. The results suggested that the concentrations of platinum(IV), Aliquat 336 and thiourea have a significant influence on the extraction of platinum (IV).

#### 4.7 Acknowledgements

The authors greatly appreciate financial support by the Thailand Research Fund through the Royal Golden Jubilee Ph.D. Program (Grant No.PHD/0297/2550). Many thanks also go to the Separation Laboratory, Department of Chemical Engineering, Chulalongkorn University, Bangkok, Thailand for supporting apparatus.

#### 4.8 Nomenclature

$A$	area of membrane (cm <sup>2</sup> )
$D_f$	diffusivity of platinum (IV) in the aqueous feed solution (cm <sup>2</sup> /s)
$D_m$	diffusivity of platinum (IV) extractant complex in the liquid membrane phase
$d_h$	hydraulic diameter of the shell side (cm)
$d_a$	diameter of the fiber bundle
$d_i$	inner diameter of the shell side (cm)
$d_o$	outer diameter of the membrane (cm)
$K$	overall mass transfer coefficient (cm/s)
$k_a$	mass transfer coefficient in the aqueous feed solution (cm/s)
$k_e$	mass transfer coefficient due to the extraction reaction (cm/s)
$k_m$	mass transfer coefficient of the membrane phase (cm/s)

$k_s$	mass transfer coefficient due to the stripping reaction (cm/s)
$k_{as}$	mass transfer coefficient for the aqueous stripping solution (cm/s)
$k_o$	mass transfer coefficient in the shell side between hollow fibers (cm/s)
$L$	fiber module length (cm)
$D_f$	partition coefficient between the organic membrane phase and the aqueous feed solution
$D_s$	partition coefficient between the organic membrane phase and the stripping solution
$Re$	Reynolds number
$Sh$	Sherwood number
$Sc$	Schmidt number
$t$	time (s)
$U_f$	flow rate inside the hollow fibers (cm/s)
$U_s$	flow rate in the shell side (cm/s)
$V_a$	volume of the aqueous feed solution (cm <sup>3</sup> )
$V_o$	volume of the organic membrane solution (cm <sup>3</sup> )

#### 4.9 References

- [1] J.Y. Lee, J.R. Kumar, J.S. Kim, D.J. Kim, H.S. Yoon, J Ind Eng Chem, 15 (2009) 359-364.
- [2] L. Zhou, J. Xu, X. Liang, Z. Liu, J. Hazard. Mater., 182 (2010) 518-524.



- [3] T.R. Reddy, N.N. Meeravali, A.V.R. Reddy, *Sep Purif Technol*, 103 (2013) 71-77.
- [4] P.P. Sun, M.S. Lee, *Hydrometallurgy*, 109 (2011) 181-184.
- [5] P.P. Sun, J.Y. Lee, M.S. Lee, *Hydrometallurgy*, 113 (2012) 200-204.
- [6] J.Y. Lee, J.R. Kumar, J.S. Kim, H.K. Park, H.S. Yoon, *J Hazard Mater*, 168 (2009) 424-429.
- [7] B. Gupta, I. Singh, *Hydrometallurgy*, 134 (2013) 11-18.
- [8] P.P. Sun, J.Y. Lee, M.S. Lee, *Mater Trans*, 52 (2011) 2071-2076.
- [9] A.N. Nikoloski, K.L. Ang, D. Li, *Hydrometallurgy*, 152 (2015) 20-32.
- [10] M. Trautmann, H.J. Holdt, *Sep Purif Technol*, 149 (2015) 279-287.
- [11] T.H. Nguyen, C.H. Sonu, M.S. Lee, *J Ind Eng Chem*, 32 (2015) 238-245.
- [12] V.C. Adya, A. Sengupta, S. Ansari, P.K. Mohapatra, M.K. Bhide, S.V. Godbole, *J Radioanal Nucl Ch*, 295 (2013) 1023-1028.
- [13] S. Suren, U. Pancharoen, N. Thamphiphit, N. Leepipatpiboon, *J Membrane Sci*, 448 (2013) 23-33.
- [14] P. Kandwal, S.A. Ansari, P.K. Mohapatra, *J Membrane Sci*, 384 (2011) 37-43.
- [15] Y.D. Jagdale, A.W. Patwardhan, K.A. Shah, S. Chaurasia, A.V. Patwardhan, S.A. Ansari, P.K. Mohapatra, *Desalination*, 325 (2013) 104-112.
- [16] I.M. Coelho, M.M. Cardoso, R.M.C. Viegas, J.P.S.G. Crespo, *Sep. Purif. Technol.*, 19 (2000) 183-197.
- [17] L.D. Mafu, T.A.M. Msagati, B.B. Mamba, *Phys Chem Earth PT A/B/C*, 50-52 (2012) 121-126.
- [18] P. Kandwal, S.A. Ansari, P.K. Mohapatra, *J Membrane Sci*, 405 (2012) 85-91.

- [19] B.F. Jirjis, S. Luque, in Chapter 9 - Practical Aspects of Membrane System Design in Food and Bioprocessing Applications, Z.F. Cui, H.S. Muralidhara Eds., pp. 179-212, Butterworth-Heinemann, Oxford (2010).
- [20] W. Zhang, C. Cui, Z. Hao, Chin. J. Chem. Eng., 18 (2010) 48-54.
- [21] R. Khalilpour, A. Abbas, Z.P. Lai, I. Pinnau, Chem. Eng. Res. Des., 91 (2013) 332-347.
- [22] N. Sunsandee, P. Ramakul, N. Thamphiphit, U. Pancharoen, N. Leepipatpiboon, Chem Eng J, 209 (2012) 201-214.
- [23] P.V. Vernekar, Y.D. Jagdale, A.W. Patwardhan, A.V. Patwardhan, S.A. Ansari, P.K. Mohapatra, V.K. Manchanda, Chem Eng Res Des, 91 (2013) 141-157.
- [24] P.C. Rout, K. Sarangi, Hydrometallurgy, 133 (2013) 149-155.
- [25] H.C. Li, V, Membrane Technology, (2010) Elsevier, ISBN 978-971-85671-85632-85673, USA., pp. 85213-85249.
- [26] T. Wannachod, P. Phuphaibul, V. Mohdee, U. Pancharoen, S. Phatanasri, Miner Eng, 77 (2015) 1-9.
- [27] S. Gupta, M. Chakraborty, Z.V.P. Murthy, Sep Purif Technol, 114 (2013) 43-52.
- [28] T. Wannachod, T. Wongsawa, P. Ramakul, U. Pancharoen, S. Kheawhom, J Ind Eng Chem, 33 (2016) 246-254.
- [29] W.D. Zhang, C.H. Cui, Z.S. Hao, Chinese J Chem Eng, 18 (2010) 48-54.
- [30] S.J. Li, H.L. Chen, L. Zhang, Sep Purif Technol, 66 (2009) 25-34.
- [31] C. Fontas, V. Salvado, M. Hidalgo, Solvent Extr Ion Exc, 17 (1999) 149-162.
- [32] Y. Tang, W. Liu, J. Wan, Y. Wang, X. Yang, Process Biochemistry, 48 (2013) 1980-1991.

- [33] Z.Q. Ren, H.L. Meng, W.D. Zhang, J.T. Liu, C.H. Cui, *Sep Sci Technol*, 44 (2009) 1181-1197.
- [34] S.R. Wickramasinghe, M.J. Semmens, E.L. Cussler, *J Membrane Sci*, 69 (1992) 235-250.
- [35] A. Baudot, J. Flourey, H.E. Smorenburg, *Aiche J*, 47 (2001) 1780-1793.
- [36] T. Wongsawa, N. Leepipatpiboon, N. Thamphiphit, U. Pancharoen, A.W. Lothongkum, *Chem Eng J*, 222 (2013) 361-373.
- [37] K. Wongkaew, N. Sunsandee, U. Pancharoen, K. Nootong, P. Ramakul, *J Ind Eng Chem*, 22 (2015) 217-228.
- [38] K. Wongkaew, U. Pancharoen, S. Phatanasri, N. Leepipatpiboon, A.W. Lothongkum, *J Ind Eng Chem*, 21 (2015) 212-220.
- [39] Z. Albaraka, Z. Asfari, J.M. Loureiro, M. Burgard, D. Trebouet, *Sep Purif Technol*, 63 (2008) 493-499.
- [40] H.H. Nejad, S.S. Zadeh, S. Alam, *Can Metall Quart*, 52 (2013) 342-347.
- [41] S.N. Duche, P.M. Dhadke, *Sep Sci Technol*, 37 (2002) 3011-3024.
- [42] M. Resina, C. Fontas, C. Palet, M. Munoz, *Desalination*, 200 (2006) 100-102.
- [43] S.K. Singh, S.C. Tripathi, P.M. Gandhi, D.K. Singh, *Sep Sci Technol*, 48 (2013) 1015-1022.
- [44] A. Bhowal, G. Bhattacharyya, B. Inturu, S. Datta, *Sep Purif Technol*, 99 (2012) 69-76.
- [45] C. Fontas, C. Palet, V. Salvado, M. Hidalgo, *J Membrane Sci*, 178 (2000) 131-139.
- [46] D. Buachuang, P. Ramakul, N. Leepipatpiboon, U. Pancharoen, *J Alloy Compd*, 509 (2011) 9549-9557.

- [47] P.R. Danesi, *J Membrane Sci*, 20 (1984) 231-248.
- [48] N. Leepipatpaiboon, U. Pancharoen, N. Sunsandee, P. Ramakul, *Korean J Chem Eng*, (2014) 1-7.
- [49] A.D. Sharma, A.W. Patwardhan, S.A. Ansari, P.K. Mohapatra, *Sep Sci Technol*, 50 (2015) 332-342.
- [50] Y.L. Mao, H. Chen, J. Han, Y. Wang, X. Tang, L. Ni, L. Wang, *J Iran Chem Soc*, 13 (2016) 403-410.
- [51] T. Wannachod, N. Leepipatpiboon, U. Pancharoen, K. Nootong, *Chem Eng J*, 248 (2014) 158-167.
- [52] C. Fontas, M. Hidalgo, V. Salvado, E. Antico, *Anal Chim Acta*, 547 (2005) 255-261.
- [53] J.C. Lee, J. Jeong, B.S. Kim, M.S. Kim, M. Kobayashi, *Mater Trans*, 45 (2004) 1915-1919.
- [54] B. Sengupta, M.S. Bhakhar, R. Sengupta, *Hydrometallurgy*, 99 (2009) 25-32.
- [55] A. Asfaram, M. Ghaedi, A. Goudarzi, M. Rajabi, *Dalton Transactions*, 44 (2015) 14707-14723.
- [56] M. Ghaedi, H.Z. Khafri, A. Asfaram, A. Goudarzi, *Spectrochimica Acta Part A: Molecular and Biomolecular Spectroscopy*, 152 (2016) 233-240.
- [57] F. Nasiri Azad, M. Ghaedi, K. Dashtian, M. Montazerzohori, S. Hajati, E. Alipanahpour, *RSC Advances*, 5 (2015) 61060-61069.
- [58] E.A. Dil, M. Ghaedi, A.M. Ghaedi, A. Asfaram, A. Goudarzi, S. Hajati, M. Soylok, S. Agarwal, V.K. Gupta, *J Ind Eng Chem*, 34 (2016) 186-197.
- [59] S. Dashamiri, M. Ghaedi, K. Dashtian, M.R. Rahimi, A. Goudarzi, R. Jannesar, *Ultrasonics Sonochemistry*, 31 (2016) 546-557.

[60] S. Mannan, A. Fakhru'l-Razi, M.Z. Alam, J Environ Sci, 19 (2007) 23-28.



**CHAPTER V****Separation of platinum (IV) across hollow fiber supported liquid membrane using non-toxic diluents: mass transfer and thermodynamics**

Krirkratthawit Wongkaew<sup>a</sup>, Vanee Mohdee<sup>a</sup>, Ura Pancharoen<sup>a,\*</sup>, Amornchai Arpornwichanop<sup>a,\*\*</sup>, Anchaleeporn W.Lothonkum<sup>b</sup>

*a: Department of Chemical Engineering, Faculty of Engineering, Chulalongkorn University, Pathumwan, Bangkok 10330, Thailand*

*b: Department of Chemical Engineering, Faculty of Engineering, King Mongkut's Institute of Technology Ladkrabang, Bangkok 10520, Thailand*

จุฬาลงกรณ์มหาวิทยาลัย  
CHULALONGKORN UNIVERSITY

## 5.1 Abstract

Non-toxic diluents were studied and compared with toxic diluents for separation of platinum (IV) across hollow fiber supported liquid membrane (HFSLM). 91.41 % extraction and 81% stripping of platinum (IV) was observed for sunflower oils at 328.15 K. Overall mass transfer resistance ( $R$ ) was  $146.612 \times 10^4$  s/cm. The separation process was exothermic ( $\Delta H_{ex}^0 = -975.20$  kJ/mol) and spontaneous ( $\Delta G_{ex}^0 = -326.447$  J/mol). The  $E_a$  of 1.673 kJ/mol indicated that the diffusion of complex species across the liquid membrane controlled the mass transfer step. Moreover, a modified Apelblat model gave an excellent match for predicting the extraction behavior of platinum (IV) at 1.2818% RMSD.

**Keywords:** platinum (IV); non-toxic diluents; sunflower oils; thermodynamics; HFSLM.

\*Corresponding author. Tel.: +66 2 218 6891; Fax: +66 2 218 6877.

E-mail addresses: [ura.p@chula.ac.th](mailto:ura.p@chula.ac.th)

\*\* Corresponding author. Tel.: + 66 2 218 6999; Fax: 662 218 6877.

E-mail addresses: [amornchai.a@chula.ac.th](mailto:amornchai.a@chula.ac.th)

## 5.2 Introduction

Platinum is a precious metal of enormous importance. There has been increasing demand for its use in various industries. Platinum is used not only in the jewelry trade but also in modern industry. Platinum is in a primary resource (ore)

which is limited. Platinum can also be found in secondary sources (i.e. wastewater). Recently, platinum has come under investigation since contamination of secondary sources has been found to contain platinum at a relatively low concentration. Thus, reliable and effective methods have to be developed for the separation and recovery of platinum (IV) from wastewater [1]. The secondary sources of wastewater from gold refining processes are of significance revealing platinum at low concentration of approximately 5 mg/L and other precious metal ions [2].

A liquid membrane system is a useful method for the separation of metal ions from wastewater because of its unique properties whereby it can extract and recover target ions simultaneously [3]. Nevertheless, the instability of supported liquid membrane (SLM) and tricky operations has blocked its applications at industrial level. Previous literature has highlighted a number of novel types of liquid membrane systems e.g. renewal SLM [4], SLM with emulsion [5] and SLM with strip dispersion [6]. Of late, among these liquid membrane types, the hollow fiber supported liquid membrane (HFSLM) system has shown a new prospective. HFSLM has more advantages such as high selectivity, simultaneous extraction and recovery of target metal ions at relatively low concentration in ppm and ppt levels. Moreover, it is easy to apply on an industrial scale [7]. Thus, HFSLM has been applied in the separation of various metal ions i.e. toxic and precious metal ions from aqueous solutions as stated elsewhere [8].

The use of toxic diluents is harmful to humans, livings and environments even though in trace level. Thus, environmentally friendly diluents (i.e.their distinctive characteristics such as nontoxicity, non-volatility, renewability and biodegradability [9]), were used instead of toxic diluents. The unlimited resources of non-toxic diluents



as well as the relatively simpler processing steps ensure the employment of vegetable oils as diluent substitutes. Diluent substitutes are also less expensive than toxic diluents. Previous works have reported the effect of vegetable oils in the liquid membrane systems in order to successfully separate and recover various compounds such as mercury [10], methylene blue [11] and copper [12]. Due to the extraction and stripping of target metal ions using non-toxic diluents, it was low when compared with toxic diluents [10, 13]. In order to improve the system for extraction and stripping of target ions, in particular at relatively low concentration (<100 ppm), energy (temperature) are introduced. Although the cost for operation increased, it is worth to investment as similar to previous publications [13-17].

This work highlights and compares the effect of non-toxic diluents with toxic diluents on the performance of extraction and stripping of platinum (IV) from gold refining wastewater, kindly supplied by Gold Field Refinery Co. Ltd, Thailand. This experiment was carried out to explore the possibility of substituting toxic diluents with environmentally friendly diluents (non-toxic diluents) such as soybean oils, sunflower oils and coconut oils. The influence of non-toxic diluents are compared with the toxic diluents (benzene, cyclohexane, chlorobenzene, chloroform, hexane and 1,2-dichloromethane). Both toxic and non-toxic diluents are reported in terms of the efficiency of extraction and stripping of platinum (IV), distribution ratio, permeability, mass transfer coefficient, selectivity, extraction equilibrium and kinetic parameters. Moreover, a modified Apelblat model was applied to correlate and predict experimental data. Finally, the accuracy of the model was validated by root-mean square deviation (RMSD).

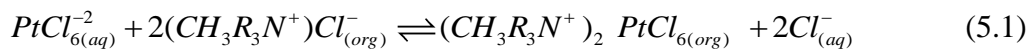
### 5.3 Theory

#### 5.3.1 Transportation of platinum (IV) across HFSLM

Separation of the target metal ions via HFSLM, using a basic extractant, involved facilitated coupled counter-transport. It can be explained as follows: the target metals  $PtCl_{6(aq)}^{-2}$  in the feed solution are transferred to the interface between the feed-liquid membrane phases. Subsequently,  $PtCl_{6(aq)}^{-2}$  reacts with the extractant  $(CH_3R_3N^+)Cl_{6(org)}^-$  to form a complex species  $(CH_3R_3N^+)_2PtCl_{6(aq)}^-$  as shown in Eq. (5.1). Then, the complex species  $(CH_3R_3N^+)_2PtCl_{6(aq)}^-$  diffuses through the liquid membrane phase to the interface between the liquid membrane and stripping phase. The occurring complex species  $(CH_3R_3N^+)_2PtCl_{6(aq)}^-$  reacts with the selected stripping agents  $(NH_2)_2CS_{(aq)}$  at the interface of the liquid membrane-stripping phase. After that,  $PtCl_{6(aq)}^{-2}$  are released into the stripping phase as illustrated in Eq. (5.2).  $PtCl_{6(aq)}^{-2}$  diffuses into the stripping solution while the released extractant  $(CH_3R_3N^+)Cl_{6(org)}^-$  from the complex species moves back to the interface of the feed-liquid membrane using the concentration gradient. At the feed-liquid membrane interface,  $(CH_3R_3N^+)Cl_{6(org)}^-$  reacts again with  $PtCl_{6(aq)}^{-2}$ .

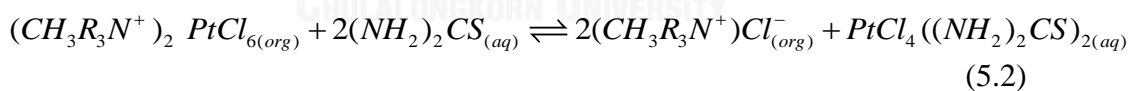
In HCl media,  $PtCl_{6(aq)}^{-2}$  is the predominant species, even at 0.1 M HCl [18]. Fontàs et al [19] proved that no polynuclear complexes are formed in the liquid phase. Taking into consideration that most Pt(IV) exists as hexachloroplatinate (IV) ion,

$PtCl_{6(aq)}^{-2}$ , high concentration of chloride. The extraction reaction of platinum (IV) using Aliquat 336 as the extractant has been published previously [19]. The extraction reaction of platinum (IV) in chloride media with Aliquat 336 is as follows:



where  $PtCl_{6(aq)}^{2-}$  is platinum (IV) in the feed solution,  $(CH_3R_3N^+)Cl_{6(org)}^-$  is the selected extractant,  $(CH_3R_3N^+)_2 PtCl_{6(aq)}$  is the complex species and  $Cl_{(aq)}^-$  is chloride ions.

The stripping of platinum (IV) with thiourea solution was reported elsewhere [20]. The stripping reaction between the complex species and the stripping solution is as follows:



where  $(NH_2)_2 CS_{(aq)}$  is the employed stripping agent in the stripping solution,  $PtCl_4((NH_2)_2 CS)_{2(aq)}$  is platinum (IV) which is stripped from the liquid membrane.

### 5.3.2 Distribution ratio, the extraction and stripping equilibrium constants

The distribution ratio of platinum (IV) between the feed phase and the liquid-membrane phase was expressed as:

$$D = \frac{[(CH_3R_3N^+)_2 PtCl_{6(org)}]}{[PtCl_{6(aq)}^{-2}]} \quad (5.3)$$

where  $[(CH_3R_3N^+)_2 PtCl_{6(org)}]$  is calculated using Eq. (5.4), describing the partition equilibrium of platinum (IV) of the HFSLM system.

$$[(CH_3R_3N^+)_2 PtCl_{6(org)}] = \frac{V_a}{V_o} [(PtCl_{6(aq)}^{2-})_{f.in} - (PtCl_{6(aq)}^{2-})_{f.out}] \quad (5.4)$$

where  $V_a$  and  $V_o$  represented volumes of the feed solution and the liquid membrane ( $cm^3$ ), respectively.

The extraction of platinum (IV) using Aliquit 336 has been explained elsewhere [19] as shown in Eq(5.1). The extraction equilibrium ( $K_{ex}$ ) can be described according to the following equation:

$$K_{ex} = \frac{[(CH_3R_3N^+)_2 PtCl_{6(org)}][Cl_{(aq)}^-]^2}{[PtCl_{6(aq)}^{2-}][[(CH_3R_3N^+)Cl_{(org)}^-]^2]} \quad (5.5)$$

The stripping of platinum (IV) from the liquid membrane phase using  $NH_2CSNH_2$  in HCl is as shown in Eq (5.2). The stripping equilibrium ( $K_{st}$ ) can be described according to the following equation:

$$K_{st} = \frac{[PtCl_4((NH_2)_2CS)_{2(aq)}][[(CH_3R_3N^+)Cl_{org}^-]^2]}{[(CH_3R_3N^+)_2 PtCl_{6(org)}][[(NH_2)_2CS_{(aq)}]^2]} \quad (5.6)$$

### 5.3.3 Permeability coefficient

Danesi [21], in accordance with the mass transfer model, reported that the permeability in feed solution  $P_F$  and in stripping solution  $P_S$  is obtained using Eqs (5.7) and (5.8):

$$\text{Feed solution: } \ln\left(\frac{C_F}{C_{FO}}\right) = \varepsilon \frac{S}{V_A} P_F t \quad (5.7)$$

$$\text{Stripping solution: } \ln\left(1 - \frac{C'}{C_{FO}}\right) = \varepsilon \frac{S}{V_B} P_S t \quad (5.8)$$

### 5.3.4 Thermodynamic parameters and activation energy ( $E_a$ )

The thermodynamic parameter for the separation of platinum (IV) in terms of extraction equilibrium directly corresponds with Van't Hoff equation. It has a relationship with the standard Gibbs free-energy ( $\Delta G_{ex}^0$ ) and Gibbs–Helmholtz equations [22].  $\Delta G_{ex}^0$  for the platinum (IV) extraction can be determined as follows:

$$\Delta G_{ex}^0 = -RT \ln K_{ex} \quad (5.9)$$

$$\ln K_{ex} = -\frac{\Delta G_{ex}^0}{RT} \quad (5.10)$$

$\Delta G_{ex}^0$  is correlated with the standard enthalpy ( $\Delta H_{ex}^0$ ) together with the extraction entropy ( $\Delta S_{ex}^0$ ) as explained by the Gibbs–Helmholtz equation. The correlation of  $\Delta H_{ex}^0$  with  $\Delta S_{ex}^0$  is according to the following equation:

$$\Delta G_{ex}^o = \Delta H_{ex}^o - T\Delta S_{ex}^o \quad (5.11)$$

Substituting Eq.(5.10) in Eq.(5.11), the Van't Hoff equation was obtained in linear form and is presented as [23]:

$$\ln K_{ex} = \frac{\Delta H_{ex}^o}{RT} - \frac{\Delta S_{ex}^o}{R} \quad (5.12)$$

A plot of  $\ln K_{ex}$  versus  $1/T$  should give a straight line and its slope and intercept is used to calculate  $\Delta H_{ex}^0$  and  $\Delta S_{ex}^0$ , respectively.

The activation energy ( $E_a$ ) has an impact on the temperature of actual rate constants. The value of  $E_a$  being lower than 20 kJ/mol demonstrated that transportation of metal ions across HFSLM is governed by pure diffusion-limited transport. However, when  $E_a$  is higher than 40 kJ/mol, this indicates that the system is controlled by the chemical reaction. Again, when  $E_a$  is in the range of 20 kJ/mol to 42 kJ/mol, this demonstrates that the process is governed by a mixture of diffusion and chemical reaction [24]. A plot of the logarithm of the flux ( $\ln J$ ) versus ( $1/T$ ) is used to determine a  $E_a$  as shown in Eq. (5.13):

$$J = Ae^{-E_a/RT} \quad (5.13)$$

where  $J$  is the flux,  $R$  denotes the universal gas constant (8.3145 J/mol K),  $A$  is the frequency factor, and  $T$  is the absolute temperature.

### 5.3.5 Mass transfer resistance

Eq. (5.14) was employed to assess overall mass transfer resistance. The mass transfer resistance for platinum (IV) through the HFSLM system is the sum of five individual mass transfer resistances. These are namely, the feed phase  $R_a$  ( $1/k_a$ ), the liquid membrane resistance  $R_m$  ( $1/k_m$ ), shell-side resistance  $R_o$  ( $1/k_o$ ), stripping reaction resistance  $R_{as}$  ( $1/k_{as}$ ) and stripping side resistance  $R_s$  ( $1/k_s$ ). The correlation of the five individual mass transfer resistances and individual mass transfer coefficients is as shown in Eqs (5.14-5.15) [25]:

$$R = R_a + R_m + R_o + R_s + R_{as} \quad (5.14)$$

Otherwise;

$$\frac{1}{K} = \frac{1}{k_a} + \frac{1}{D_f k_m} + \frac{1}{D_f k_o} + \frac{1}{D_s k_s} + \frac{1}{(D_s / k_s) k_{as}} \quad (5.15)$$

The values of  $k_s$  and  $k_{as}$  in Eq. (5.15) can be ignored because the stripping reaction is instantaneous [25, 26]:

$$\frac{1}{K} = \frac{1}{k_a} + \frac{1}{D_f k_m} + \frac{1}{D_f k_o} \quad (5.16)$$

The L ev eque equation was calculated using the relationship of the Schmidt correlations ( $Sc$ ) and Sherwood ( $Sh$ ) [27].

$$Sh = 1.62 \left( \frac{d_i}{L} ReSc \right)^{0.33} \quad (5.17)$$

where  $Re$ ,  $Sh$  and  $Sc$  can be defined as follows:

$$Re = \frac{4Q_f}{\mu\pi d_i}$$

$$Sh = \frac{K_f d_i}{D_f}$$

$$Sc = \frac{\nu}{D_f}$$

The value of  $Re$  was calculated as 30.17, which was lower than 2,700, demonstrating that the laminar flow occurred inside the hollow fibers. Consequently,  $k_a$  was calculated as follows [26]:



$$k_a = 1.62 \frac{D_f}{d_i} \left( \frac{d_i v_f}{LD_f} \right)^{0.33} \quad (5.18)$$

The values of  $k_m$  can be determined as follows:

$$k_m = \frac{D_m \varepsilon d_{lm}}{\delta \eta d_o} \quad (5.19)$$

The values of  $k_o$  can be calculated using the correlation of the Sherwood and Schmidt correlation [26]:

$$k_o = 1.25 \frac{D_m}{d_h^{0.07}} \left( \frac{d_h v_s}{\nu L} \right)^{0.93} \left( \frac{\nu_s}{D_m} \right)^{0.33} \quad (5.20)$$

The hydraulic diameter is determined as follows [28, 29]:

$$d_h = \frac{d_a^2 - d_i^2 - nd_0^2}{nd_0} \quad (5.21)$$

where  $d_h$  is the hydraulic diameter of the shell side (cm),  $d_i$  is the inner diameter of the shell side (cm) and  $d_o$  is the outer diameter of the membrane (cm).

### 5.3.6 The modified Apelblat equation

Generally, the relationship between extracted mole fraction of the solubility correlated as a function of temperature is expressed according to [30, 31]. The following equation was applied to predict the percentages of extraction across HFSLM:

$$\ln x = A + \frac{B}{T} + C \ln T \quad (5.22)$$

where  $T$  represents the absolute temperature,  $A$ ,  $B$  and  $C$  represent model parameters,  $x$  is the mole fraction of platinum(IV) or % extraction at the investigated temperature. The constant values of  $A$  and  $B$  stand for the variation in the solution activity coefficient. The constant value of  $C$  reflects the influence of temperature upon the fusion enthalpy [32].

A program of Minitab Statistical Software version 17 was employed to find the curve fitting of models in order to estimate parameters involved in the modified Apelblat equation. The procedure of curve fitting was employed to foretell and express the accuracy of this model. A set of best fit parameters was estimated by using a nonlinear least squares method, trust-region algorithms and LAR robust method. The error between the calculated and predicted responses for performance of extraction of platinum (IV) was represented by root-mean square deviation (RMSD).

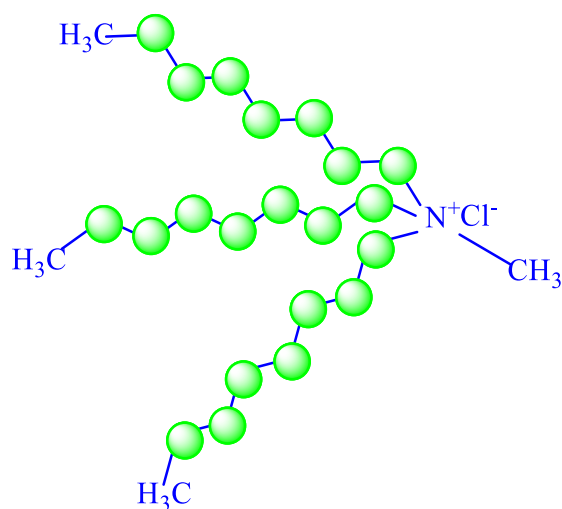
The corresponding root-mean square deviation (RMSD) is determined as follows:

$$\text{RMSD} = \sqrt{\frac{\sum_{i=1}^N (E_{i,\text{cal}} - E_{i,\text{exp}})^2}{N}} \quad (5.23)$$

## 5.4 Experiment

### 5.4.1 Chemicals and reagents

Wastewater from gold refining processes are quite significant sources which contain platinum at a low concentration approximately 5 mg/L and other precious metal ions [38]. The properties of feed solutions from gold refining processes are shown in **Table 5.1**. The wastewater was kindly supplied by Gold Field Refinery Co. Ltd, Thailand. Platinum (IV) in the aqueous solutions was analyzed by ICP–OES. Hydrophobic liquid membrane was prepared by impregnating with tri-n-octylmethylammonium (Aliquat 336) in the micro-porous hollow fibers. Its structures are reported in **Fig.5.1** [2]. Thiourea ( $\text{NH}_2\text{CSNH}_2$ ) (98% purity) and hydrochloric acidic solution (HCl) (37% purity) was used as stripping agents. Hydrochloric acid and sodium hydroxide (97% purity from Sigma-Aldrich) were used to adjust the pH of feed solutions. All toxic diluents used in these experiments were purchased from Sigma-Aldrich and listed in **Table 5.2**. Non-toxic diluents were purchased in the local markets in Thailand. The properties of non-toxic diluents are listed in **Table 5.3**. All reagents used in this experiment were of analytical grade. Double distilled water of  $8.2 \text{ M}\Omega\cdot\text{cm}^{-1}$  was used throughout the experiments.



**Fig.5. 1** The structures of Aliquat 336

**Table 5. 1** The properties of feed solutions from gold refining processes

Parameter	Value
Color	Brownish
Temperature (°C)	30
pH	6.6
Pt(IV) (ppm)	5
Au(III) (ppm)	0.94
Pd(II) (ppm)	0.88
Cu(II) (ppm)	0.55
Zn(II) (ppm)	0.12
Na(I) (ppm)	3892.45
Conductivity ( $\mu\text{s}/\text{cm}$ )	2850

**Table 5. 2** The properties of toxic diluents

Properties	H	CY	CH	B	1,2-D	CHI
Chemical formula	C <sub>6</sub> H <sub>14</sub>	C <sub>6</sub> H <sub>12</sub>	C <sub>6</sub> H <sub>5</sub> Cl	C <sub>6</sub> H <sub>6</sub>	C <sub>2</sub> H <sub>4</sub> Cl <sub>2</sub>	CHCl <sub>3</sub>
MW (g/mol)	86.18	84.16	112.56	78.11	98.95	119.37
Purity (%)	95	99.5	99.8	99.9	99.8	-
Analysis method of purity (%)	GC	GC	GC	GC	GC	-
Density (g/cm <sup>3</sup> )	0.6548	0.7781	1.11	0.8765	1.253	1.489
Viscosity (cP) (20°C)	0.3	1.02	0.714	0.6076	0.84	0.117
Surface tension (dyn/cm) (20°C)	18.43	24.95	33.60	28.88	26.50	27.50
Dielectric constant (at 25°C)	1.88	2.02	5.62	2.3	8.93	4.81
Polarity index (P')	0.1	0.2	2.5	2.7	3.1	4.1

**Note:** 1,2-D (1, 2-dichloromethane ); H (hexane); CY (cyclohexane); CH(chlorobenzene); B(benzene) and CHI(chloroform)

**Table 5. 3** The properties of non-toxic diluents

Properties	coconut oil	soybean oil	sunflower oil
Density (g/cm <sup>3</sup> )[33, 34]	0.9150	0.9185	0.9169
Viscosity (cP)(20°C)[35] [36]	55.0	54.3	41.6
Surface tension (dyn/cm) (20°C) [33, 37, 38]	33.40	33.85	33.50
Dielectric constant (at 25°C)	27	N/A	25
Polarity index (P')	N/A	N/A	N/A

#### 5.4.2 Apparatus

The HFSLM of Celgard®x-40 microporous fibers used throughout the experiments is comprised of a hollow fiber module, gear pumps, rotameters, variable flow rate controllers and pressure gauges. The unique characteristics of this module are presented in **Table 5.4**. The temperature of feed and stripping solutions was controlled by using a heater and stirrer (model CMT-V1; Protronics Intertrade Co. Ltd. Thailand). The professional pH Meter PP-50 (TransInstruments, Singapore) was employed to measure the pH values of the feed solution using hydrochloric acidic solution and sodium hydroxide solution to adjust the pH of the feed solution. A pump from Cole-Parmer, USA with 8.6 bar (125 psi) was used throughout the experiments. The inductively coupled plasma optical emission spectrometer (ICP-OES) (model JY

2000–2; HORIBA Jobin Yvon, France) was employed to measure the concentration of platinum (IV) in all samples.

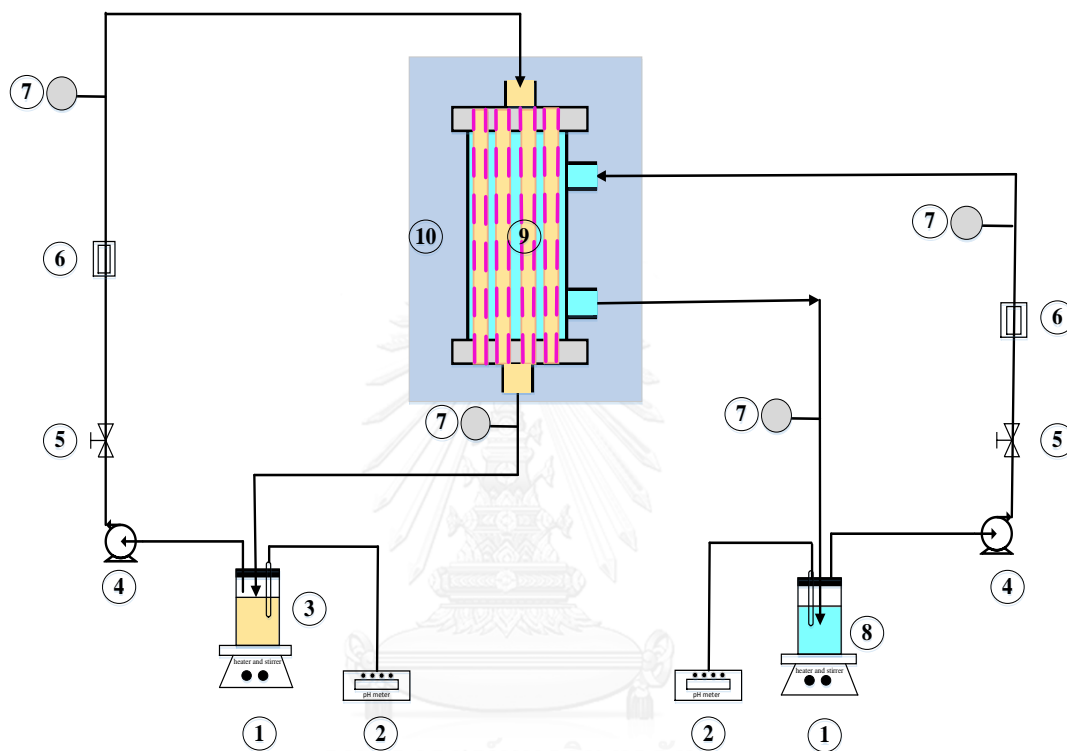
**Table 5. 4** Physical characteristics of the hollow fiber module

Characteristics	Descriptions
Material	polypropylene
Number of fibers	35,000
Fiber inside diameter (cm)	0.024
Fiber outside diameter (cm)	0.03
Effective length (cm)	19.8
Surface area (cm <sup>2</sup> )	1.4 x 10 <sup>4</sup>
Area per unit volume (cm <sup>2</sup> /cm <sup>3</sup> )	29.3
Membrane porosity	25%
Average pore size (cm)	3x10 <sup>-6</sup>
Membrane tortuosity	2.6
Module diameter (cm)	6.3
Module length (cm)	20.3
temperature (K)	273 – 333

### 5.4.3 Procedures

In the sequence of experiments, Aliquat 336, dissolved in many investigated diluents, was used as the liquid membrane. A schematic diagram of the HFSLM module employed in this experiment is shown below in **Fig 5.2** [2]. The temperature of the HFSLM system was controlled by a thermostatically controlled bath which was

checked using a digital thermometer (with an accuracy of  $\pm 0.1$  K) while the temperature of the feed and stripping solution was controlled by a heater and stirrer.



**Fig.5. 2** Flow diagram in the HFSLM system: (1) stirrer and heater (2) pH meter (3) feed reservoir (4) pressure indicator (5) flow regulator valve (6) flow indicator (7) pressure indicator (8) stripping reservoir, (9) HFSLM and (10) thermostatically controlled bath

A mixture of extractant and diluent was used to prepare the liquid membrane. The mixture was pumped into the tube and shell sides of the hollow fibers for 40 min at the flow rates of 100 mL/min, ensuring that the extractant was entirely impregnated in the micro-pores of the hollow fibers [2, 39]. After impregnation was completed,



the tube and shell sides were washed by distilled water in order to remove excess liquid membrane from the HFSLM module. Subsequently, both feed and stripping solutions, each of 3000 cm<sup>3</sup>, were fed into the tube and shell sides of the hollow fibers. Volumes of samples (10 cm<sup>3</sup>) were withdrawn from the outlet feed and stripping solutions at the desired time intervals. Samples were analyzed by ICP–OES. When each experiment was finished, regeneration of the hollow fiber module was required for a new separation cycle. Both feed and stripping sides of the hollow fiber module were continuously washed by deionized water and followed by ethyl alcohol for 60 min in order to remove the liquid membrane in the micro-pores of the hollow fibers. After that, isopropyl alcohol was employed to dry the inside of the HFSLM system. Each analysis was carried out in duplicate in order to confirm the efficiency and reliability of the separation of platinum (IV) across the HFSLM system. The efficiency of separation of platinum(IV) can be calculated by using the same correlation as reported earlier [2].

Optimized parameters such as the impregnated time (40 min) of the liquid membrane in the micro-pores of the hollow fibers, the operating times of 30 min, 10% (v/v) Aliquat 336 as the liquid membrane phase, 0.8 M NH<sub>2</sub>CSNH<sub>2</sub>(thiourea) in 1 M HCl (hydrochloric acid) as the stripping solution, equally flow rates of feed and stripping of 100 mL/ min, were reported in our previous work [2].

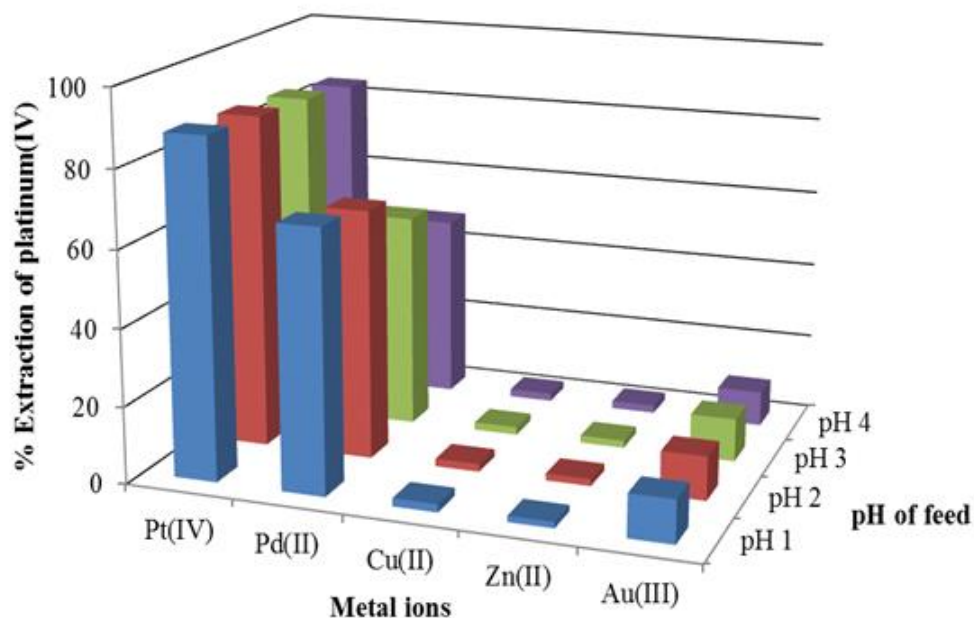
## **5.5 Results and discussion**

### **5.5.1 The pH values of feed solution**

The pH of the feed solution plays a significant role in the transport of metal ions across the liquid membrane phase because it has a direct effect on the efficiency of the extractant to form complex species with metal ions [39, 40]. Accordingly, the experimental results are revealed below in **Fig.5.3**, indicating that the efficiency of extraction of platinum (IV) was somewhat excellent at pH ranging 1-4pH. This was because Aliquat 336 is a water insoluble quaternary ammonium salt produced by the methylation of mixed trioctyl/ decyl amine, which is capable of forming oil soluble salts of anionic species at acidic or slightly alkaline pH. It is composed of a large organic cation associated with a chloride ion,  $(CH_3R_3N^+)Cl_{(org)}^-$ . As the ammonium structure has a permanent positive charge, it can form salts with anions over a wider pH range than primary, secondary or tertiary amines. At a lower feed solution, in particular pH 1, percentage of extraction of platinum (IV) was also high in line with pH 2 of feed solution. However, pH 1 of feed solution was not recommended because at a highly acidic state the HFLSM fibers became frayed [39, 41]. In case of other competing anions on the extraction and stripping, the results were shown in **Fig.3**, indicating that other metal ions were also extracted. In particular Pd(II). This was because in hydrochloric acid/chloride media, Pd(II) can form four chlorocomplexes ,i.e.,  $[PdCl]^-$ ,  $[PdCl_2]$ ,  $[PdCl_3]^-$  and  $[PdCl_4]^-$ . In reality,  $[PdCl_4]^-$  is the predominant species [42]. The selectivity was controlled by adjusting the types of extractants, stripping agent and pH of feed solution [43, 44]. In this study, the formation of target ions in feed solution is formed in different forms at pH 2. Platinum (IV) and palladium (II) are in form of  $PtCl_6^{2-}$  and  $PdCl_4^{2-}$ , respectively. Aliquat 336 which composed of a large organic cation associated with a chloride ion,

$(CH_3R_3N^+)Cl_{(org)}^-$ , can extract both  $PtCl_6^{2-}$  and  $PdCl_4^{2-}$  [45, 46]. However,  $PdCl_4^{2-}$  is lower stripped from the liquid membrane. Like, the effect of 2-ethylhexyl-2-ethylhexyl phosphoric acid (HEHEPA) on the extraction and stripping of Nd(III) from other rare earth metals [47]. The selectivity of platinum (IV) from other metal ions in terms of the separation factor was published in our previous paper [48]”. In further experiments, pH 2 of feed solution was recommended for the separation of platinum (IV).





**Fig.5. 3** The influence of pH of feed solution on the extraction of platinum(IV) from wastewater under 10% (v/v) Aliquat 336, 0.8 M  $\text{NH}_2\text{CSNH}_2$  in 1 M HCl, equal flow rates of feed and stripping at 100 mL/min and operating at ambient temperature

### 5.5.2 Influences of toxic diluents on the extraction and stripping of platinum (IV)

The suitable diluents were selected based on requirements in order to facilitate immobilize in the hollow fiber pores i.e. high capacity for dissolving carrier and also allow ion-pair formation between target ion and extractant selected, low viscosity because of promoting high target ion fluxes through the liquid membrane and low toxicity [49]. Various polar diluents were employed to select the suitable diluents for platinum (IV) extraction and stripping, using Aliquat 336 as the extractant.

When comparison of the various toxic diluents was completed, it was found that the order of extraction power was hexane < cyclohexane < chlorobenzene < benzene < 1,2-dichloromethane < kerosene < chloroform as shown in **Figs. 5.4(a-b)**. Of the seven diluents, chloroform was found to be the best since it had the highest permeability coefficient and distribution ratio as shown in **Table 5.5**. It was found that the polarity indexes increased, resulting in slight increase of the efficiency of extraction and stripping of platinum (IV) because of closely individual polarity indexes, for example, the percentages of extraction and stripping of chloroform (polarity indexes: 4.1) were approximately 99 and 88, respectively while hexane (polarity indexes: 0.1) of 85 and 76, respectively. This was corresponded with the separation of Co(II) and Ni(II) from thiocyanate media as reported by Leepitapiboon et al [17]. This can be attributed to the fact that these diluents with polarity indexes (lower than polarity indexes of water) can mix well with Aliquat 336, enhancing transport of complex species across liquid membrane phases. However, when diluents with high polarity indexes are close to the polarity index of water (9.0), the stability of the liquid membrane decreased because of greater solubility of diluents in the aqueous feed and stripping phases [17]. This is because the polar molecules of diluents interact more strongly with the polar molecules of water. In other words, if the investigated diluents have close polarity indexes with water, the liquid membrane leaks out from the pores of the hollow fibers. Moreover, the higher the increase of polarity index of diluents results in the interface layers ( $\delta$ ) was thin, enhancing transport of complex species across liquid membrane phases, obtaining higher extraction and stripping [50].

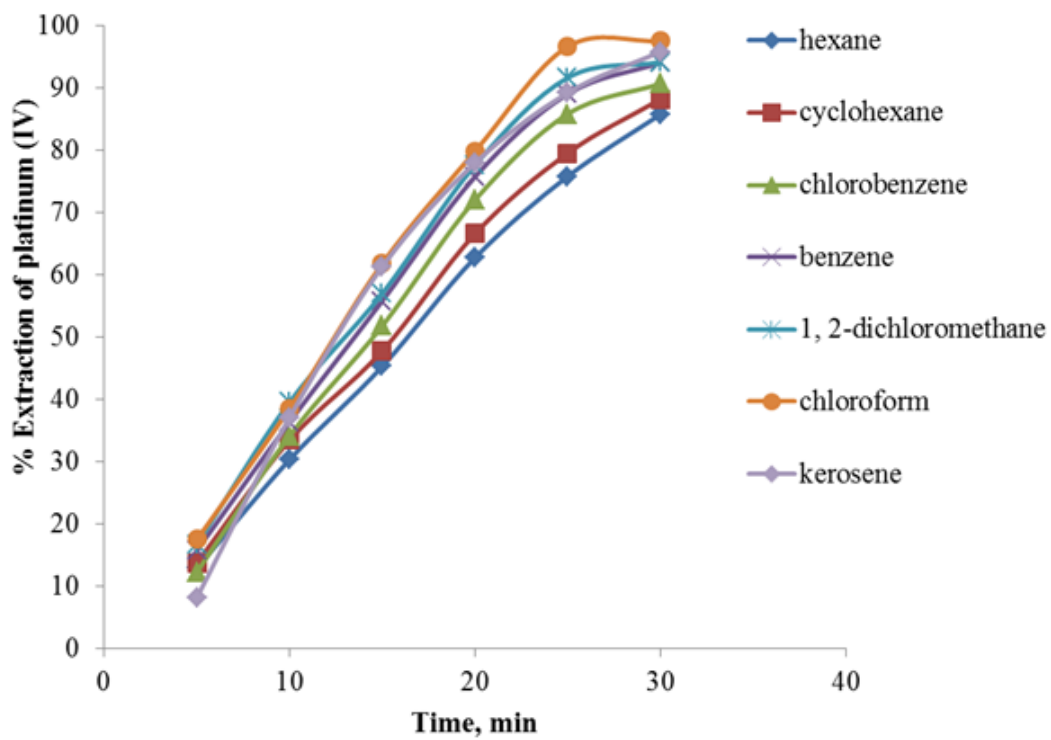
From **Table 5.5**,  $K_{ex}$  increases it means that the affinity of the metal for the organic phase or liquid membrane phase increases. while  $K_{st}$  decrease, for example,

$K_{ex}$  and  $K_{st}$  for chloroform are  $0.4617 \times 10^{-8}$  and  $2.9865 \times 10^{-11}$ , respectively. The value of  $K_{st}$  will increase or decrease, depending on the properties of liquid membrane phase (metal ions + diluent + extractant) and types and concentration of stripping agents. In previous work [48], we investigated the efficiency of types and concentration of stripping agents such as  $NH_2CSNH_2$  in HCl,  $NH_4OH$ ,  $NH_4Cl$ ,  $NaClO_4$  and  $Na_2S_2O_3$  for use as stripping solution for recovery of target metal ions from liquid membrane phase. Results demonstrated that the efficiency of stripping agents is  $NH_2CSNH_2$  in HCl >  $NaClO_4$  >  $Na_2S_2O_3$  >  $NH_4Cl$  >  $NH_4OH$ . This is due to the fact that  $NH_2CSNH_2$  in HCl has stronger de-complexation ability to platinum (IV) than other reagents [51].

In **Table 5.6**, the accumulation of target metal ions was observed because the permeability coefficients in the feed and stripping phases as calculated from Eqs (5.7-5.8) differ. This may be the properties of complex species dissolved in different diluents as generated in the liquid membrane i.e.  $(CH_3R_3N^+)_2PtCl_{6(aq)}$  and the efficiency of stripping agents selected for removing target ions  $PtCl_{6(aq)}^{2-}$  from the liquid membrane phase [13-17, 52]. In the liquid membrane phase, viscosity of extractants and diluents impacts on the diffusivity and increases membrane phase resistance as shown in Eq (5.24) [53] as follows:

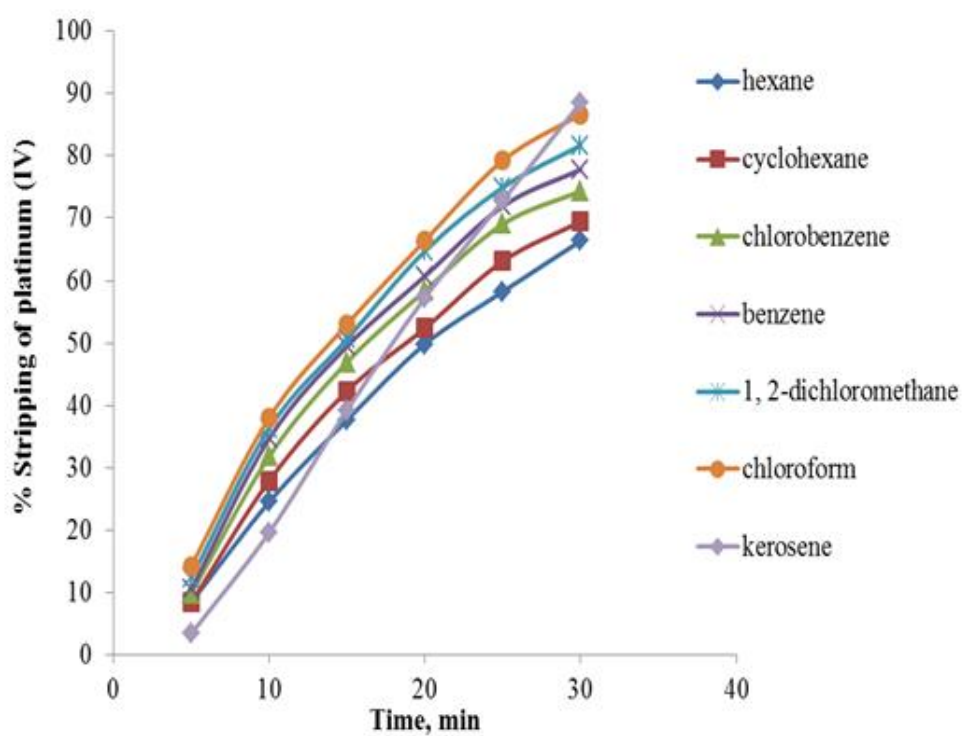
$$D^* = \frac{kT}{6\pi\eta r} \quad (24)$$

where  $D^*$  is the diffusion coefficient ( $\text{cm}^2/\text{s}$ ),  $k$  is the Boltzmann constant,  $T$  is the absolute temperature,  $\eta$  is the viscosity of the liquid phase, and  $r$  is the molecular radius of the solute (cm).



CHULALONGKORN UNIVERSITY

(a)



(b)

**Fig.5. 4** The effects of types of toxic diluents on (a) the extraction (b) the stripping for platinum (IV) across liquid membrane under optimized conditions under optimized conditions



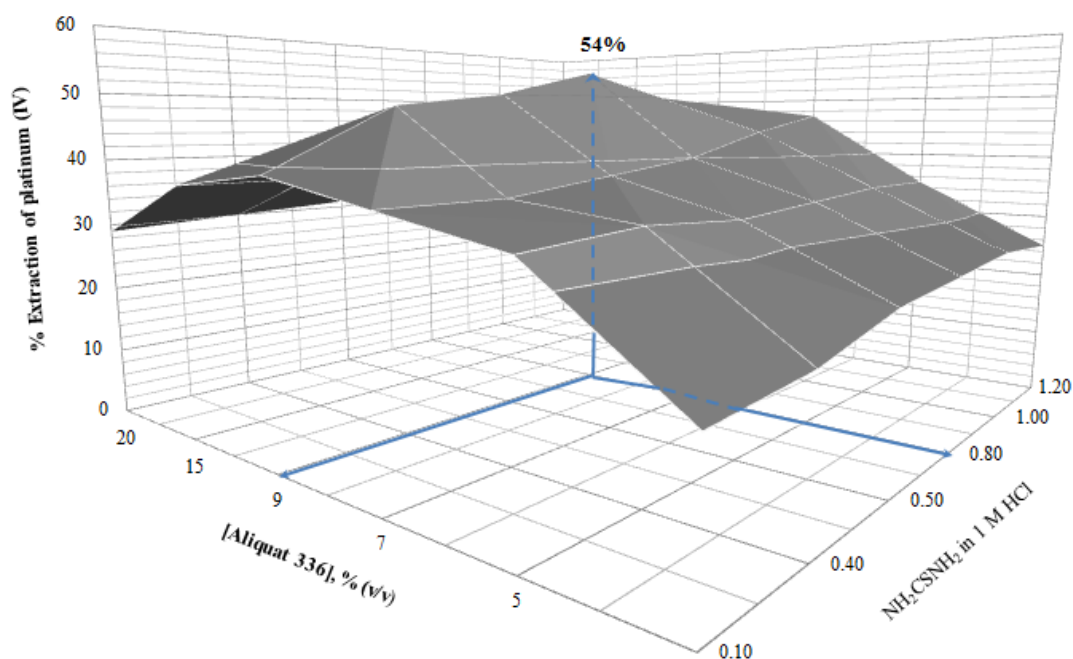
**Table 5. 5** The effect of toxic diluents on extraction equilibrium constants, stripping equilibrium constants, distribution ratios and permeability coefficient under optimized conditions

Diluents	$K_{ex} \times 10^8$	$K_{st} \times 10^{11}$	$D_F$	$D_S$	$P_F(\text{cm/s}) \times 10^4$	$P_S(\text{cm/s}) \times 10^4$
hexane	5.5744	4.3288	0.8568	0.7745	1.7115	0.9520
cyclohexane	7.2352	4.2875	0.8812	0.7882	1.8895	1.0465
chlorobenzene	9.9659	3.8493	0.9062	0.8206	2.2199	1.2107
benzene	0.1732	3.9782	0.9398	0.8281	2.5915	1.3277
1, 2- dichloromethane	0.1767	3.1714	0.9408	0.8682	2.6915	1.4914
chloroform	0.4617	2.9865	0.9748	0.8892	3.6365	1.7588
kerosene	0.2603	2.2619	0.9576	0.9246	2.8861	1.9406

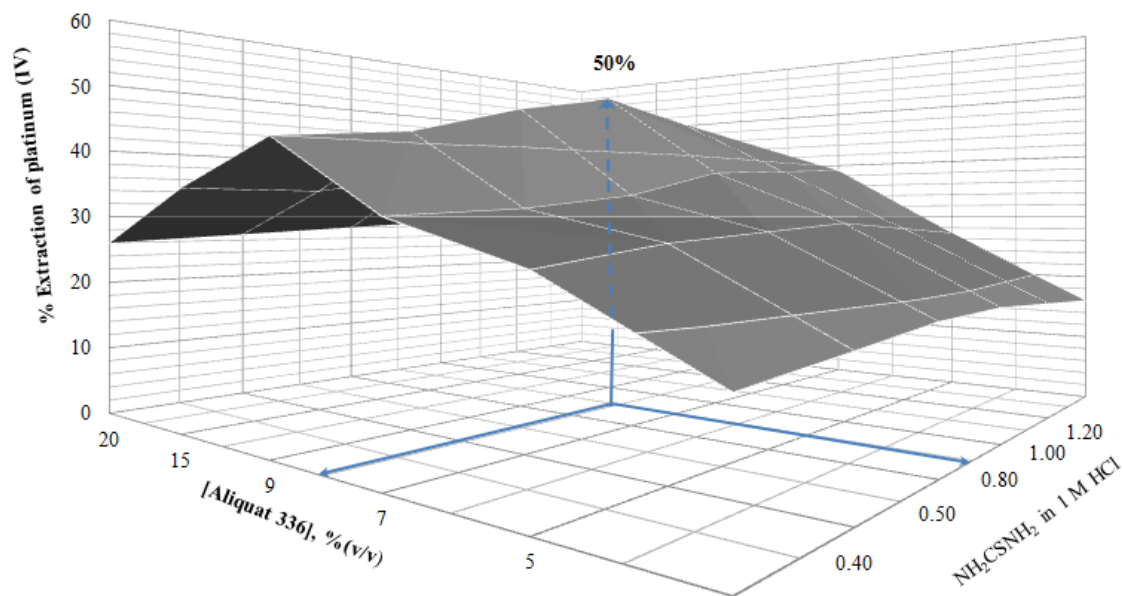
### 5.5.3 Influences of non-toxic diluents on the extraction and stripping of platinum (IV)

In order to develop safer and more non-toxic diluents, soybean oil, sunflower oil and coconut oil which are nontoxic, nonvolatile, renewable and bio-degradable, were investigated. In **Table 5.6**, the results show the effect of three non-toxic diluents in terms of the extraction equilibrium constants, stripping equilibrium constants,

distribution ratios and permeability coefficients. The trends of  $K_{ex}$  and  $K_{st}$  for non-toxic diluents are similar to toxic diluents but the values of  $K_{ex}$  and  $K_{st}$  are lower than toxic diluents. This may be in relation to its viscosity as reported in section 4.2. For instance, the values of  $K_{ex}$  and  $K_{st}$  for sunflower oil were  $0.1020 \times 10^{-9}$  and  $7.9628 \times 10^{-12}$ . In **Figs. 5.5(a-c)**, results demonstrate that sunflower oil (65%) shows higher performance for extraction of platinum (IV) as compared with coconut oil and soybean oil. In this study, the experimental results achieved verify that the HFSLM system as developed with Aliquat 336 /sunflower oil as the liquid membrane could be a useful tool for recovering platinum (IV) from wastewater.

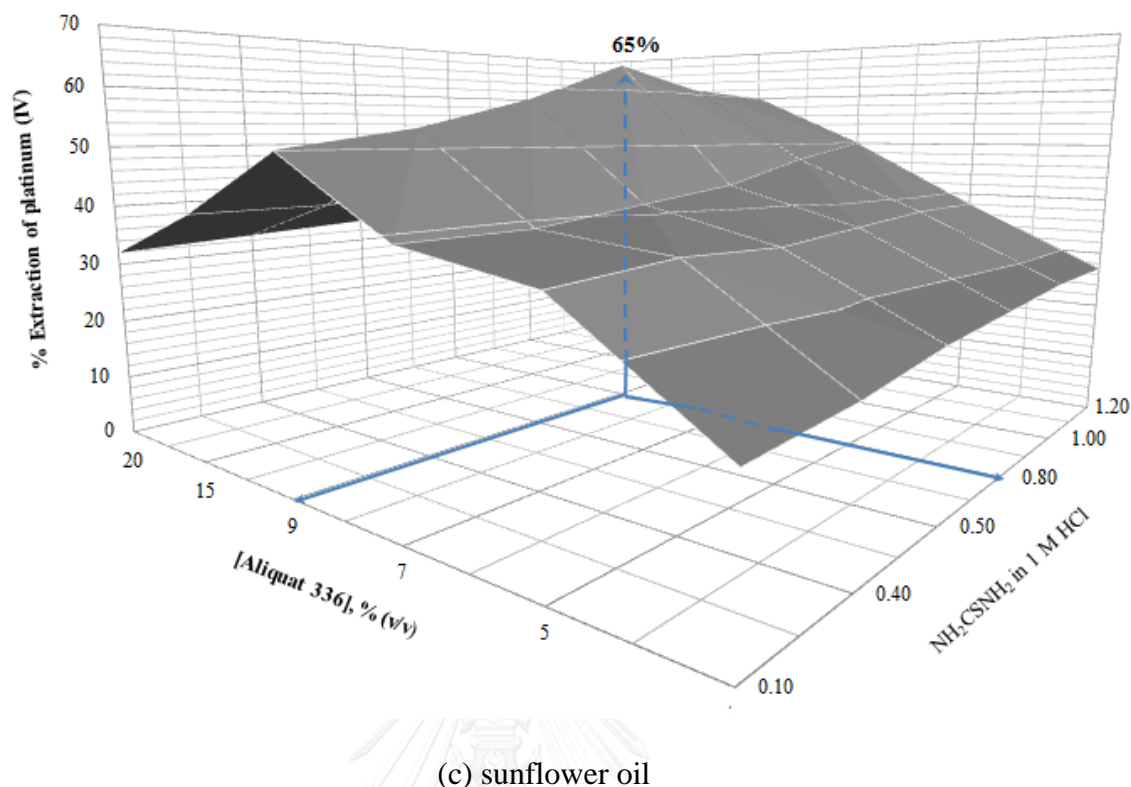


(a) coconut oil



(b) soybean oil





**Fig.5. 5** The effects of types of non-toxic diluents (a) coconut oil (b) soybean oil and (c) sunflower oil on the extraction of platinum (IV) across liquid membrane under optimized conditions

From **Table 5.6**, permeability of the non toxic diluents was decreased when compared with toxic diluents. This may be attributed to membrane saturation, lower effective membrane area, saturation of the membrane pores with the metal ion-extractant species  $(CH_3R_3N^+)_2PtCl_{6(aq)}$  and the build-up of a layer on the membrane interface [54]. Moreover, at higher concentration of the liquid membrane, the decrease of permeability can be explained in terms of the increase in viscosity that increases membrane resistance [54]. In order to overcome, viscosity and mass transfer problems

in the liquid membrane phase, the experiments may be operated purposely at temperatures greater than the room temperature[55].

**Table 5. 6** The effect of non-toxic diluents on extraction equilibrium constants, stripping equilibrium constants, distribution ratios and permeability coefficients

Non-toxic diluents	$K_{ex} \times 10^9$	$K_{st} \times 10^{12}$	$D_F(-)$	$D_S (-)$	$P_F(\text{cm/s}) \times 10^5$	$P_S(\text{cm/s}) \times 10^5$
coconut oil	2.1309	4.7579	0.4528	0.9329	0.5532	0.4894
soybean oil	3.3842	5.3499	0.5094	0.9482	4.0057	0.5722
sunflower oil	0.1020	7.9628	0.6546	0.9609	6.2332	0.8904

#### 5.5.4 Effect of temperature on non-toxic diluents for separation of platinum (IV)

From the previous experiment, sunflower oil was found to be the best non-toxic diluent for the separation of platinum (IV) from wastewater. However, the percentages of extraction were still low when compared with toxic diluents. In order to enhance its efficiency, operating temperature was investigated. This is because temperature is an ascendant parameter for regulating and adapting the percentages of extraction and stripping of metal ions together with their selectivity [17]. Nowadays, the use of the HFSLM system in the extraction and stripping of metal ions is

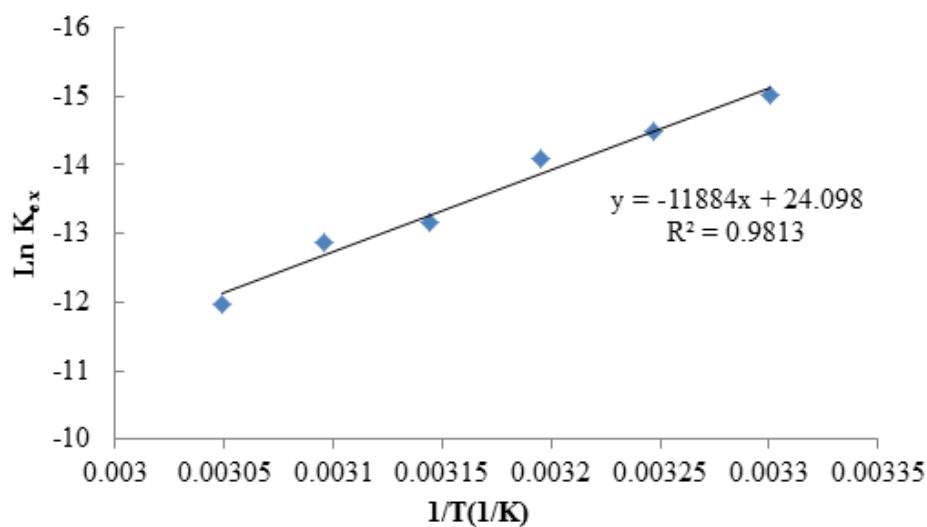
extensively undertaken due to its simplicity, low cost, low energy consumption and high separation factors. Nevertheless, very little or no reports have been carried out concerning the effect of temperature on HFSLM using non-toxic diluents [56].

In **Table 5.7**, temperature in the range of 303.15 K to 328.15 K on the extraction of platinum (IV) was adjusted. Experimental results indicated that when operating temperature was increased, the efficiency of extraction increased i.e. from 65% at 303.15 K to approximately 91% at 328.15 K for sunflower oil. This is because when operating temperature increased, the diffusion coefficients of platinum (IV) in both the feed-liquid membrane phase and liquid membrane-stripping phase increased, whereas the viscosity of the liquid membrane phase decreased [17].

**Table 5. 7** The effect of temperature on efficiency of extraction of platinum (IV) using various non-toxic diluents

Temperature (K)	% Extraction of platinum(IV)		
	Coconut oil	Soybean oil	Sunflower oil
303.15	45.28	50.94	65.46
308.15	47.38	55.73	67.18
313.15	49.93	58.19	70.14
318.15	53.14	56.40	75.97
323.15	55.93	66.02	88.83
328.15	60.39	80.02	91.41

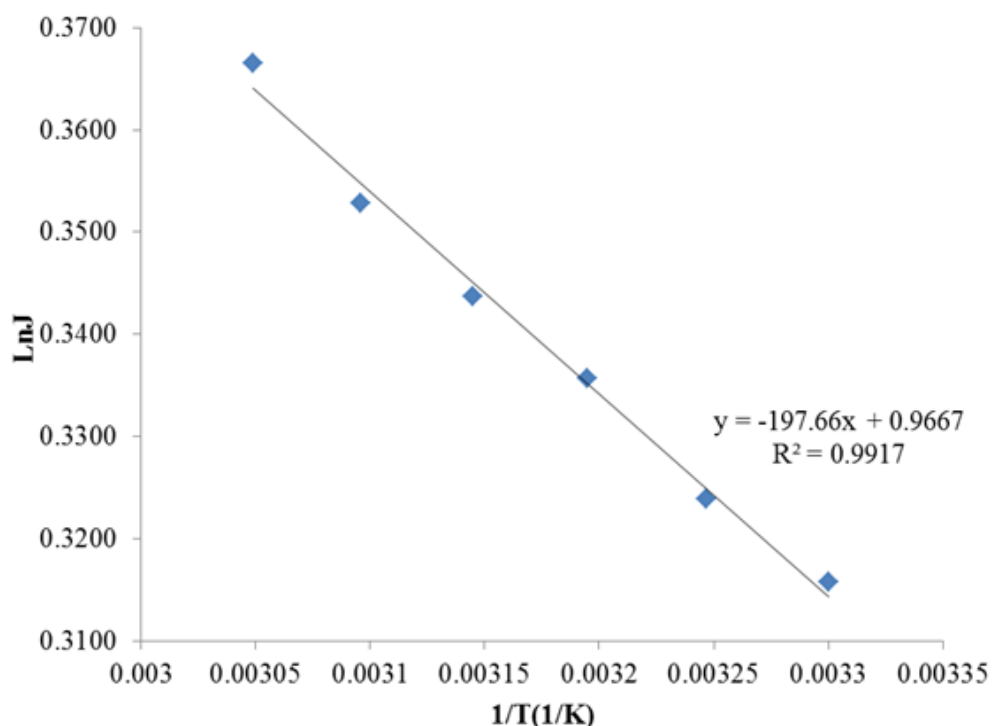
The plot of  $\log K_{ex}$  versus  $1/T$  yields straight lines with slopes proportional to the enthalpy. Examination of **Fig. 5.6** shows straight lines with slopes of -11884.6 for Pt(IV) extraction. The negative values of the enthalpy changes,  $\Delta H_{ex}^{\circ}$  -975.20 kJ mol<sup>-1</sup> Pt(IV) extraction calculated from the slopes of the linear relations indicate the exothermic nature of the Pt(IV) extraction processes[57]. From Eq(5.12), the evaluated thermodynamic parameters provide further information into both the aqueous phase complexation and the organic phase reactions. The value of  $T\Delta S_{ex}^{\circ} > \Delta H_{ex}^{\circ}$ , the standard Gibbs free energy changes  $\Delta G_{ex}^{\circ}$  are negative, referring to the spontaneous nature of Pt(IV) extraction reactions with  $(CH_3R_3N^+)Cl_{6(org)}^-$  [58]. The negative value  $\Delta S_{ex}^{\circ}$  was -1.977 J/K mol, implying the degree of order has increased during the extraction process [57]. In fact, the bonding, which involves the electrostatic attraction between oppositely charged ions, is responsible for a decrease in the randomness of the system and gives a negative entropy contribution.



**Fig.5.6** The Van't Hoff equation plot between  $\ln K_{ex}$  and  $1/T$  under optimized conditions

The value of  $E_a$  was achieved by a plot of flux ( $J$ ) and ( $1/T$ ) as presented in Eq. (5.13). Results as illustrated in **Fig.5.7** noted that the value  $E_a$  of 1.673 kJ/mol was obtained from the slope of the curve. The results reveal that the process controlling the transport of platinum (IV) across HFSLM is the diffusion.



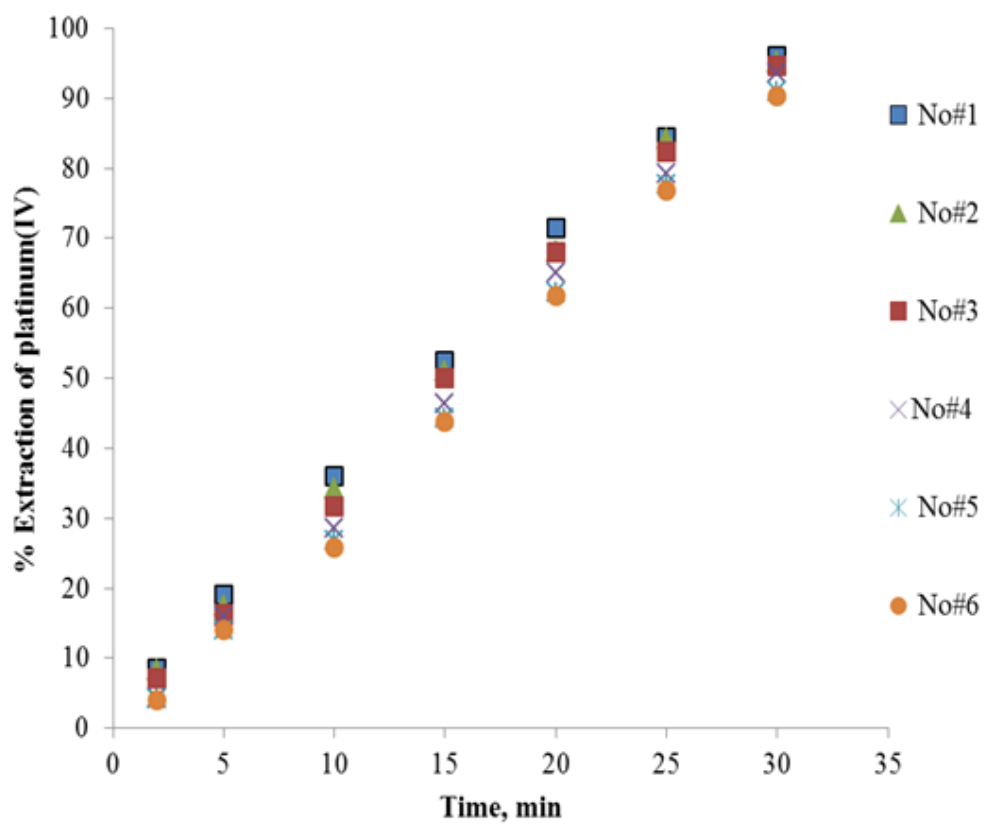


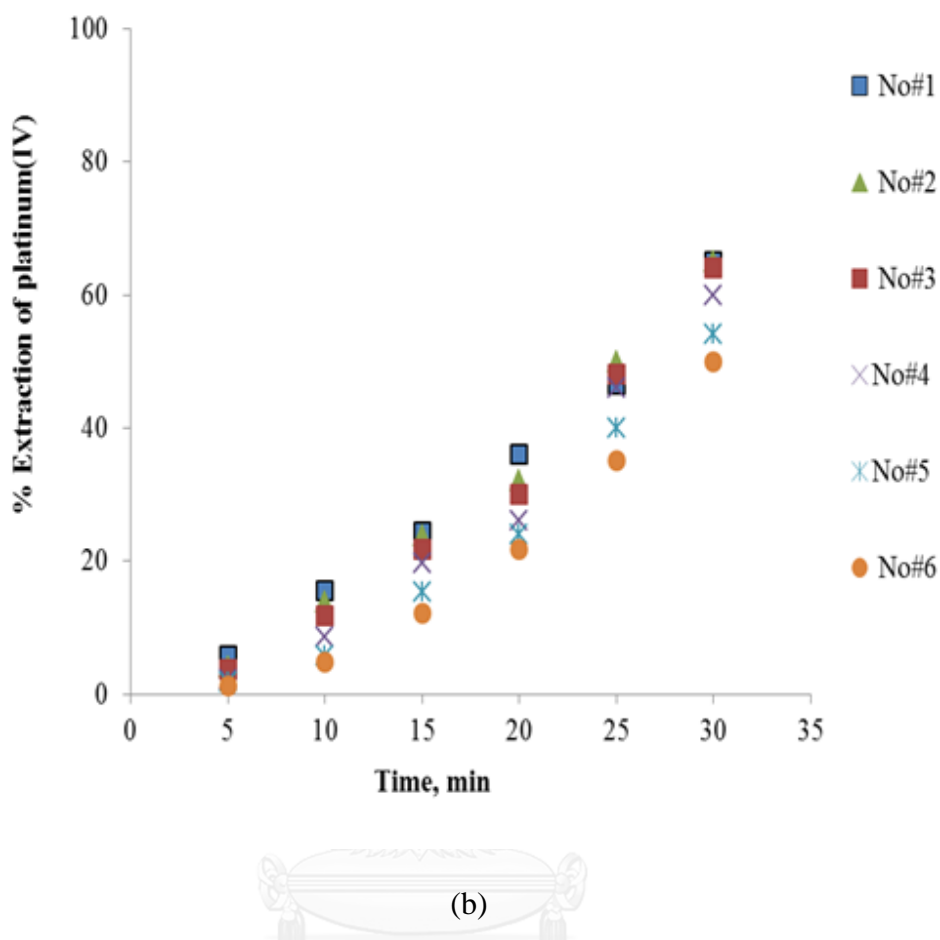
**Fig.5. 7** The Arrhenius plot of platinum (IV) transport, plotting between  $\ln J$  and  $1/T$  under optimized conditions

### 5.5.5 The number of cycles

The major challenge of the HFSLM system was to ensure that the micro-pores of the hollow fibers were fully embedded with the organic solvent (extractant and diluent). For development of commercial processes, the instability of the HFSLM system is a major obstacle. Thus, it should be investigated. The instability of the liquid membrane may be due to the loss of the liquid membrane from the micro-pores of the hollow fibers into the feed and the stripping solutions [59-62]:

**Figs. 5.8 (a-b)** illustrate the percentages of extraction of platinum (IV) versus the operation of each number of cycles using chloroform (standing for toxic diluents) and sunflower oil (standing for non-toxic diluents). Results indicated that there is a slight decrease in the efficiency of extraction during the course of six consecutive cycles for both chloroform and sunflower oil. This is because of a loss of the extractant or diluent. Similar results were obtained by Guell et al.[63]and Ren et al. [26]. They reported that a decrease in the efficiency of both extraction and stripping is due to a loss of the extractant or diluent from the support pores [64]. However, chloroform seems more stable than sunflower oil. This can be attributed to the fact that chloroform with polarity indexes and low viscosity can mix well with Aliquat 336, enhancing the transport of complex species across the liquid membrane phase. Moreover, the stripping agents (0.8 M  $\text{NH}_2\text{CSNH}_2$  in 1 M HCl) has stronger de-complexation ability to platinum (IV) using chloroform as diluents than sunflower oil [51].





**Fig.5. 8** Efficiency of extraction of platinum (IV) versus time at various number of separation cycles across HFSLM using (a) chloroform and (b) sunflower oil

### 5.5.6 Mass transfer coefficients

In **Table 5.8**, the four individual transfer resistances are listed. In the case of kerosene,  $R$  was determined and found to be  $6.865 \times 10^4$  s/cm [2]. The mass transfer resistances from the liquid membrane phase proved to be much higher than that from the mass transfer resistance across the feed phase and the shell side mass transfer resistances. This demonstrated that the mass transfer resistances from the feed phase

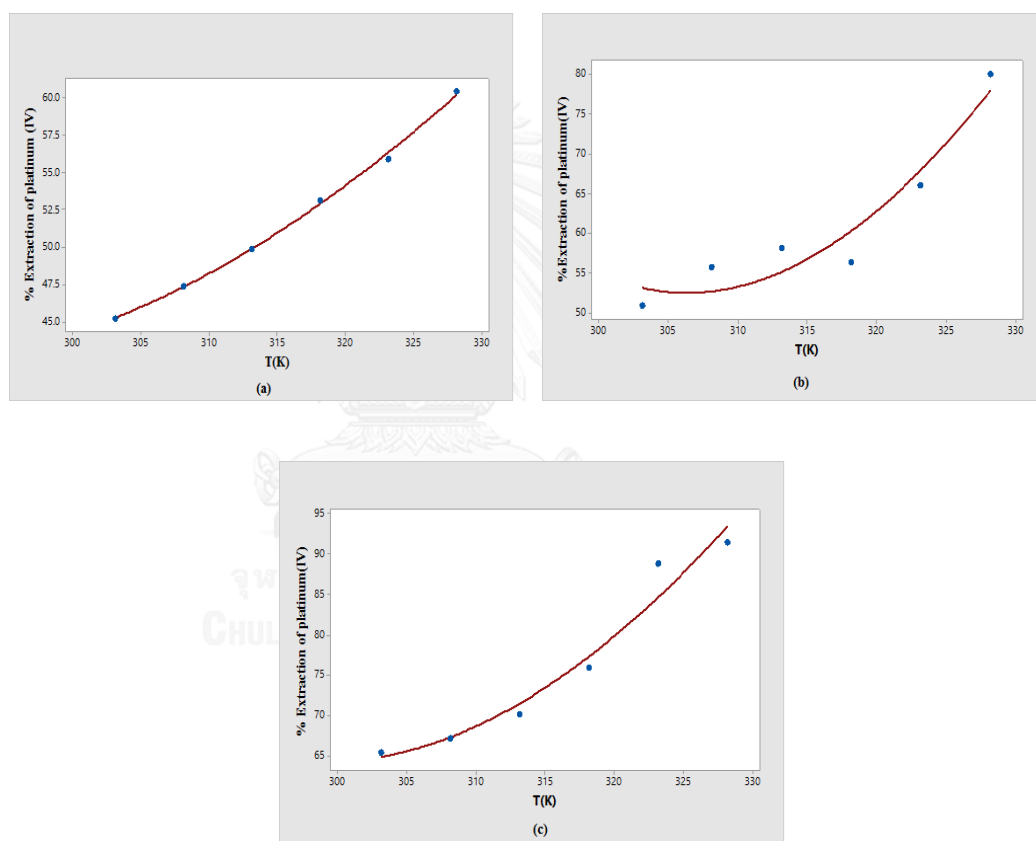
and the shell side had less influence on the overall mass transfer process. The individual transfer resistances of hexane, cyclohexane, chlorobenzene, benzene, 1, 2-dichloromethane, chloroform, coconut oil, soybean oil and sunflower oil are listed in **Table 5.8**. Thus, it can be concluded that the transportation of platinum (IV) across the HFSLM system in all investigated diluents was controlled by the mass transfer resistance from the liquid membrane.

**Table 5.8** The effect of non-toxic diluents and toxic diluents on the mass transfer resistances

Diluents	$R$ (s/cm)	$R_a$ (s/cm) $\times 10^{-4}$	$R_o$ (s/cm) $\times 10^{-4}$	$R_m$ (s/cm) $\times 10^{-4}$
hexane	4.759	3.297	1.196	0.133
cyclohexane	7.358	3.297	3.928	0.138
chlorobenzene	6.209	3.297	2.779	0.134
benzene	5.807	3.297	2.377	0.133
1, 2- dichloromethane	6.684	3.297	3.254	0.133
chloroform	3.911	3.297	0.481	0.133
kerosene	6.865	3.297	0.404	0.164
coconut oil	101.286	3.297	97.636	0.353
soybean	136.842	3.297	133.409	0.136
sunflower	146.612	3.297	143.179	0.133

### 5.5.7 Modeling

In **Table 5.9**, a set of best fit parameters is listed. The results as shown in **Fig. 5.9** demonstrate that the modified Apelblat equation was in good agreement with the experimental data for all the various diluents investigated. The values of RMSE for predictions were low as shown in **Table 5.9**.



**Fig.5. 9** Results from comparisons between a modified Apelblat equation versus various temperatures by adjusting of non-toxic diluents (a) coconut oil, (b) soybean oil and (c) sunflower oil

**Table 5. 9** Estimated model parameters of a modified Apelblat model for non-toxic diluents

Types of diluents	A	B	C	RMSE
coconut oil	-14498	628851	2182	0.5447
soybean	-74085	3377692	11024	1.2431
sunflower	-47385	2119068	7081	1.2818

## 5.6 Conclusion

This work concerns the effect of diluents on the separation of platinum (IV) from wastewater across the HFSLM system. Results found that the characteristics of each diluent are significantly responsible not only for the efficiency of extraction and stripping of platinum (IV) but also for the lifetime of the complex species staying in the liquid membrane phase. A complete separation of platinum (IV) with 99% extraction and 88% stripping by using chloroform as a diluent was achieved at room temperature. Moreover, it was found that non-toxic diluents can replace toxic-diluents. At 328.15 K, using sunflower oils, 91.41 % extraction and 81% stripping of platinum (IV) was observed. The use of HFSLM impregnated by non-toxic diluents can be a promising green technology over HFSLM impregnated toxic diluents. The thermodynamic parameters for sunflower oils such as  $\Delta G$ ,  $\Delta H$  and  $\Delta S$  were calculated

and found to be -326.45 J/mol, -975.20 J/mol and 1.977 kJ/mol K, respectively. The calculated results demonstrated that the separation process of platinum (IV) was endothermic and spontaneous. The activation energy ( $E_a$ ) of the platinum (IV) extraction reaction was 1.673 kJ/mol. This indicated that the diffusion of complex species across the liquid membrane was the mass transfer-controlling step for the separation of platinum (IV) via HFSLM. Finally, a modified Apelblat equation was applied to explain the transport of platinum (IV) in terms of efficiency of extraction across HFSLM. The calculated results from the model were in good agreement with the experimental data at 1.2818% RMSD.

### 5.7 Acknowledgements

The financial assistance of the Thailand Research Fund through the Royal Golden Jubilee Ph.D. Program (Grant No.PHD/0297/2550, is gratefully acknowledged. Many thanks also go to the Separation Laboratory, Department of Chemical Engineering, Chulalongkorn University, Bangkok, Thailand for supporting apparatus.

### 5.8 Nomenclature

A	parameter in the modified Apelblat equation (5.22)
B	parameter in the modified Apelblat equation (5.22)
C	parameter in the modified Apelblat equation (5.22)
$D_f$	diffusivity of platinum (IV) in the aqueous feed solution ( $\text{cm}^2/\text{s}$ )



$D_m$	diffusivity of platinum (IV) extractant complex in the liquid membrane phase
$d_h$	hydraulic diameter of the shell side (cm)
$d_a$	diameter of the fiber bundle
$d_i$	inner diameter of the shell side (cm)
$d_o$	outer diameter of the membrane (cm)
$K$	overall mass transfer coefficient (cm/s)
$k_a$	mass transfer coefficient in the aqueous feed solution (cm/s)
$k_e$	mass transfer coefficient due to the extraction reaction (cm/s)
$k_m$	mass transfer coefficient of the membrane phase (cm/s)
$k_s$	mass transfer coefficient due to the stripping reaction (cm/s)
$k_{as}$	mass transfer coefficient for the aqueous stripping solution (cm/s)
$k_o$	mass transfer coefficient in the shell side between hollow fibers (cm/s)
$k$	Boltzmann constant
$L$	fiber module length (cm)
$D_f$	partition coefficient between the organic membrane phase and the aqueous feed solution
$D_s$	partition coefficient between the organic membrane phase and the stripping Solution
$D^*$	diffusion coefficient (cm <sup>2</sup> /s),

$Re$	Reynolds number
$r$	molecular radius of the solute (cm).
$Sh$	Sherwood number
$Sc$	Schmidt number
$T$	absolute temperature
$t$	time (s)
$v_f$	flow rate inside the hollow fibers (cm/s)
$v_s$	flow rate in the shell side (cm/s)
$V_a$	volume of the aqueous feed solution (cm <sup>3</sup> )
$V_o$	volume of the organic membrane solution (cm <sup>3</sup> )
$\eta$	viscosity of the liquid phase

## 5.9 References

- [1] B. Gupta, I. Singh, *Hydrometallurgy*, 134 (2013) 11-18.
- [2] K. Wongkaew, T. Wannachod, V. Mohdee, U. Pancharoen, A. Arpornwichanop, A.W. Lothongkum, *J Ind Eng Chem*, 42 (2016) 23-35.
- [3] W.D. Zhang, C.H. Cui, Z.Q. Ren, Y. Dai, H.L. Meng, *Chem Eng J*, 157 (2010) 230-237.
- [4] L. Pei, L.M. Wang, W. Guo, N. Zhao, *Acta Chim Sinica*, 69 (2011) 1553-1558.
- [5] H.D. Zheng, J.J. Chen, B.Y. Wang, S.Y. Zhao, *Chinese J Chem Eng*, 21 (2013) 827-834.
- [6] M.E. Vilt, W.S.W. Ho, *J Membrane Sci*, 367 (2011) 71-77.
- [7] P.V. Vernekar, A.W. Patwardhan, A.V. Patwardhan, S.A. Ansari, P.K. Mohapatra, V.K. Manchanda, *Sep. Sci. Technol.*, 48 (2013) 1003-1014.
- [8] V.C. Adya, A. Sengupta, S. Ansari, P.K. Mohapatra, M.K. Bhide, S.V. Godbole, *J Radioanal Nucl Ch*, 295 (2013) 1023-1028.
- [9] S.H. Chang, T.T. Teng, N. Ismail, *J Hazard Mater*, 181 (2010) 868-872.
- [10] K. Chakrabarty, P. Saha, A.K. Ghoshal, *J Membrane Sci*, 350 (2010) 395-401.
- [11] P. Kazemi, M. Peydayesh, A. Bandegi, T. Mohammadi, O. Bakhtiari, *Chem Pap*, 67 (2013) 722-729.
- [12] P. Venkateswaran, A.N. Gopalakrishnan, K. Palanivelu, *J Environ Sci-China*, 19 (2007) 1446-1453.
- [13] S. Chaturabul, W. Srirachat, T. Wannachod, P. Ramakul, U. Pancharoen, S. Kheawhom, *Chem Eng J*, 265 (2015) 34-46.

- [14] A.W. Lothongkum, P. Ramakul, W. Sasomsub, S. Laoharochanapan, U. Pancharoen, *J Taiwan Inst Chem E*, 40 (2009) 518-523.
- [15] A.W. Lothongkum, S. Suren, S. Chaturabul, N. Thamphiphit, U. Pancharoen, *J Membrane Sci*, 369 (2011) 350-358.
- [16] S. Suren, T. Wongsawa, U. Pancharoen, T. Prapasawat, A.W. Lothongkum, *Chem Eng J*, 191 (2012) 503-511.
- [17] N. Sunsandee, N. Leepipatpiboon, P. Ramakul, T. Wongsawa, U. Pancharoen, *Sep Purif Technol*, 102 (2013) 50-61.
- [18] V.T. Nguyen, J.-c. Lee, A. Chagnes, M.-s. Kim, J. Jeong, G. Cote, *Rsc Adv*, 6 (2016) 62717-62728.
- [19] C. Fontas, V. Salvado, M. Hidalgo, *Solvent Extr Ion Exc*, 17 (1999) 149-162.
- [20] J.Y. Lee, J.R. Kumar, J.S. Kim, D.J. Kim, H.S. Yoon, *J Ind Eng Chem*, 15 (2009) 359-364.
- [21] H.K. Alpoguz, A. Kaya, I. Sener, *J Macromol Sci A*, 44 (2007) 1061-1068.
- [22] M. Arisaka, T. Kimura, *Solvent Extr Ion Exc*, 29 (2011) 72-85.
- [23] B.B. Adhikari, M. Gurung, H. Kawakita, K. Ohto, *Solvent Extr Ion Exc*, 31 (2013) 483-498.
- [24] R. Davarkhah, F. Khanramaki, M. Asgari, B. Salimi, P. Ashtari, M. Shamsipur, *J Radioanal Nucl Ch*, (2013) 1-8.
- [25] Y. Tang, W. Liu, J. Wan, Y. Wang, X. Yang, *Process Biochemistry*, 48 (2013) 1980-1991.
- [26] Z.Q. Ren, H.L. Meng, W.D. Zhang, J.T. Liu, C.H. Cui, *Sep Sci Technol*, 44 (2009) 1181-1197.

- [27] S.R. Wickramasinghe, M.J. Semmens, E.L. Cussler, *J Membrane Sci*, 69 (1992) 235-250.
- [28] A. Baudot, J. Floury, H.E. Smorenburg, *Aiche J*, 47 (2001) 1780-1793.
- [29] P.V. Vernekar, Y.D. Jagdale, A.W. Patwardhan, A.V. Patwardhan, S.A. Ansari, P.K. Mohapatra, V.K. Manchanda, *Chem Eng Res Des*, 91 (2013) 141-157.
- [30] X. Liu, Y. Hu, W. Yang, Y. Liu, M. Liang, *Fluid Phase Equilibr*, 360 (2013) 134-138.
- [31] G.-M. Yu, L.-S. Wang, L.-K. Jiang, J. Sun, *Fluid Phase Equilibr*, 396 (2015) 50-57.
- [32] C. Wu, J. Li, H. Dong, J. Jiang, *Thermochim Acta*, 543 (2012) 24-31.
- [33] B. Esteban, J.R. Riba, G. Baquero, R. Puig, A. Rius, *Fuel*, 102 (2012) 231-238.
- [34] C. Tangsathitkulchai, Y. Sittichaitaweekul, M. Tangsathitkulchai, *J Am Oil Chem Soc*, 81 (2004) 401-405.
- [35] R.C. Parente, C.A. Nogueira, F.R. Carmo, L.P. Lima, F.A.N. Fernandes, R.S. Santiago-Aguiar, H.B. Sant'Ana, *J Chem Eng Data*, 56 (2011) 3061-3067.
- [36] G. Sanaiotti, C.A.S. da Silva, A.G. Parreira, M.R. Totola, A.J.A. Meirelles, E.A.C. Batista, *J Chem Eng Data*, 55 (2010) 5237-5245.
- [37] E.A. Melo-Espinosa, Y. Sánchez-Borroto, M. Errasti, R. Piloto-Rodríguez, R. Sierens, J. Roger-Riba, A. Christopher-Hansen, *Energy Procedia*, 57 (2014) 886-895.
- [38] C.A.W. Allen, K.C. Watts, R.G. Ackman, *J Am Oil Chem Soc*, 76 (1999) 317-323.
- [39] T. Wongsawa, N. Leepipatpiboon, N. Thamphiphit, U. Pancharoen, A.W. Lothongkum, *Chem Eng J*, 222 (2013) 361-373.

- [40] L.D. Mafu, T.A.M. Msagati, B.B. Mamba, *Phys Chem Earth*, 50-52 (2012) 121-126.
- [41] S. Chaturabul, K. Wongkaew, U. Pancharoen, *Sep Sci Technol*, 48 (2013) 93-104.
- [42] V.T. Nguyen, J.C. Lee, A. Chagnes, M.S. Kim, J. Jeong, G. Cote, *Rsc Adv*, 6 (2016) 62717-62728.
- [43] A.D. Sharma, A.W. Patwardhan, S.A. Ansari, P.K. Mohapatra, *Sep Sci Technol*, 50 (2015) 332-342.
- [44] Y.L. Mao, H. Chen, J. Han, Y. Wang, X. Tang, L. Ni, L. Wang, *J Iran Chem Soc*, 13 (2016) 403-410.
- [45] K. Wongkaew, N. Sunsandee, U. Pancharoen, K. Nootong, P. Ramakul, *J Ind Eng Chem*, 22 (2015) 217-228.
- [46] K. Wongkaew, U. Pancharoen, S. Phatanasri, N. Leepipatpiboon, A.W. Lothongkum, *J Ind Eng Chem*, 21 (2015) 212-220.
- [47] T. Wannachod, N. Leepipatpiboon, U. Pancharoen, K. Nootong, *Chem Eng J*, 248 (2014) 158-167.
- [48] K. Wongkaew, T. Wannachod, V. Mohdee, U. Pancharoen, A. Arpornwichanop, A.W. Lothongkum, *J Ind Eng Chem*.
- [49] F.J. Alguacil, C. Caravaca, M.I. Martin, *J Chem Technol Biot*, 78 (2003) 1048-1053.
- [50] N. Sunsandee, P. Ramakul, U. Pancharoen, N. Leepipatpiboon, *Sep Purif Technol*, 116 (2013) 405-414.
- [51] J.Y. Lee, J.R. Kumar, J.S. Kim, H.K. Park, H.S. Yoon, *J Hazard Mater*, 168 (2009) 424-429.

- [52] X.J. Yang, A.G. Fane, C. Pin, *Chem Eng J*, 88 (2002) 37-44.
- [53] D. Buachuang, P. Ramakul, N. Leepipatpiboon, U. Pancharoen, *J Alloy Compd*, 509 (2011) 9549-9557.
- [54] N. Hajarabeevi, I. Mohammed Bilal, D. Easwaramoorthy, K. Palanivelu, *Desalination*, 245 (2009) 19-27.
- [55] O.O. Fasina, Z. Colley, *International Journal of Food Properties*, 11 (2008) 738-746.
- [56] M. Michel, L. Chimuka, E. Cukrowska, P. Wieczorek, B. Buszewski, *Anal Chim Acta*, 632 (2009) 86-92.
- [57] Y.A. El-Nadi, N.E. El-Hefny, H.F. Aly, *Int J Min Met Mater*, 20 (2013) 713-719.
- [58] F. Kong, J.L. Liao, S.D. Ding, Y.Y. Yang, H. Huang, J.J. Yang, J. Tang, N. Liu, *J Radioanal Nucl Ch*, 298 (2013) 651-656.
- [59] C. Clement, M.M. Hossain, *Separ Sci Technol*, 32 (1997) 2685-2703.
- [60] Y.T. Ong, K.F. Yee, Y.K. Cheng, S.H. Tan, *Sep Purif Rev*, 43 (2014) 62-88.
- [61] M. Szpakowska, O.B. Nagy, *J Membrane Sci*, 129 (1997) 251-261.
- [62] N.M. Kocherginsky, Q. Yang, L. Seelam, *Sep Purif Technol*, 53 (2007) 171-177.
- [63] R. Guell, E. Antico, V. Salvado, C. Fontas, *Sep Purif Technol*, 62 (2008) 389-393.
- [64] C. Fontas, C. Palet, V. Salvado, M. Hidalgo, *J Membrane Sci*, 178 (2000) 131-139.

## CHAPTER VI

### CONCLUSION AND RECOMMENDATIONS

#### 6.1 Conclusion

The results from this dissertation and from our previous investigations and other researchers proved that the HFSLM system is the most effective method for the separation of a very low concentration of various target species in ppm to ppb level, e.g., metal ions [1-6], organic compounds [7, 8] and enantiomers [9-11]. HFSLM can be used in several area applications. In this work, the HFSLM system successfully separate palladium(II) from the flexible printed circuit board wastewater [5, 6] and platinum(IV) from gold refining wastewater at a relatively low concentration [4, 12]. Simultaneous extraction and stripping of the target ions in a single-step operation makes the process very compact and requires less energy consumption and residence time. The advantages of HFSLM over traditional methods include less solvent used and high selectivity. It can be easy scalability by connecting in parallel or in series to obtain a larger capacity for selective separation.

This dissertation is divided into four parts:

- 1) Effect of diluent polarity on membrane stability in the separation of Pd(II) from FPCB wastewater using LIX84-I as the extractant [6]
- 2) Purification of Sn(IV) and the extraction of Pd(II) from FPCB wastewater [5]
- 3) Mass transfer resistance and response surface methodology for separation of Pt(IV) from GR wastewater [4]
- 4) Separation of Pt(IV) using natural solvents substituting to organic solvents [12].



The results indicated the highest Pd(II) extraction and stripping (96% and 91%, respectively). The optimized conditions were feed solution pH 2, 5%(v/v) LIX84-I dissolved in kerosene as the extractant (liquid membrane), 0.8 M  $\text{NH}_2\text{CSNH}_2$  mixed with 1 M HCl as the stripping solution, and equal flow rates of feed and stripping solutions of 100 mL/min. It was found that the diluents with lower polarity indexes could prolong membrane stability. However, the percentages of extraction and stripping decreased. By using hexane, with a polarity index of 0.1, the longest stability of the liquid membrane of 350 min was achieved. The operating temperature in a range of 30–50 °C had a slight effect on the separation of Pd(II). The extraction reaction of LIX84-I with Pd(II) was controlled by a mixed regime both kinetic and diffusion due to the activation energy,  $E_a = 30$  kJ/mol. Reproducibility of the liquid membrane is found to be excellent in the recycling mode. The HFSLM system is able to successfully extract and strip Pd(II) from the FPCB wastewater.

Purification of stannous ions and recovery of palladium were achieved by using LIX 84-I. Under the optimal conditions, 100% palladium can be recovered from FPCB wastewater, and 84% stannous remaining in the feed solution can be purified. The stoichiometric coefficient ( $n$ ) of LIX 84-I for the combination of Sn(IV) and Pd(II) is equal to 2.0. The optimal conditions consist of 0.06 M LIX 84-I, 6 M HCl as stripping solution, equal flow rates of feed and stripping solutions at 100 mL/min, and a system temperature of 25 °C. The mass transfer coefficients of the aqueous feeds,  $k_{i, Sn}$  and  $k_{i, Pd}$ , were  $5.70 \times 10^{-5}$  and  $3.11 \times 10^{-3}$  cm/s, respectively. The organic phase mass transfer coefficients,  $k_{m, Sn}$  and  $k_{m, Pd}$ , were  $2.18 \times 10^{-4}$  and  $1.75 \times 10^{-4}$  cm/s, respectively. Therefore, the rate-controlling step for Sn(IV) was the diffusion of stannous through the film layer between the feed and the liquid membrane. On the

other hand, the rate-controlling step for Pd(II) was the diffusion of palladium complex through the liquid membrane. The kinetic reaction orders of both Sn(IV) and Pd(II) ( $m$ ) were equal to 1.0 and the reaction rate constants were 0.00301 and 0.08509  $\text{min}^{-1}$ , respectively.

The separation of platinum(IV) was investigated using different extractants (Aliquat 336, LIX84-I, Cyanex 923, TBP and TOPO). Results indicated that Aliquat 336 is a stronger extractant than LIX84, Cyanex 923, TBP and TOPO for the given conditions. Extraction of platinum(IV) reached 96% when Aliquat 336 was used under optimized conditions. It is because Aliquat 336 is a water insoluble quaternary ammonium salt produced by the methylation of mixed trioctyl/ decyl amine which is capable of forming oil soluble salts of anionic species at acidic or slightly alkaline pH. It is composed of a large organic cation associated with a chloride ion,  $(CH_3R_3N^+)Cl_{(org)}^-$ . Because the ammonium structure has a permanent positive charge, it can form salts with anions over a wider pH range than primary, secondary or tertiary amines. The mass transfer resistance for Aliquat 336 was investigated. The following resistances were obtained, namely, the liquid membrane resistance ( $1/k_m$ ) of  $0.164 \times 10^4$  s/cm, aqueous solution in the feed phase resistance ( $1/k_a$ ) of  $3.297 \times 10^4$  s/cm, organic phase shell-side resistance ( $1/k_o$ ) of  $3.404 \times 10^4$  s/cm and overall mass transfer resistance ( $1/K$ ) of  $6.865 \times 10^4$  s/cm. Thus, it can be verified that the HFSLM system was governed by the mass transfer resistance from the liquid membrane. Experimental results, after three identical runs, were found to be excellent. Next, response surface methodology (RSM) was investigated in order to determine the optimum values for the independent variables. Results showed that the

HFSLM system could effectively separate platinum (IV) from gold refining wastewater. A quadratic regression model showed the interaction between independent parameters (concentrations of platinum(IV), Aliquat 336 and thiourea). The significant regression coefficient ( $p < 0.05$ ) proved that this model fitted in well with the experimental data. The results suggested that the concentrations of platinum(IV), Aliquat 336 and thiourea had significant influence on the extraction of platinum(IV) from gold refining wastewater.

The effects of diluents on the separation of platinum(IV) from gold refining wastewater across the HFSLM system was investigated. Results found that the characteristics of each diluent are significantly responsible not only for the efficiencies of extraction and stripping of platinum (IV) but also for the lifetime of the complex species in the liquid membrane phase. A complete separation of platinum(IV) with 99% extraction and 88% stripping using chloroform as a diluent was achieved at room temperature. Moreover, it was found that non toxic diluents could replace toxic diluents. At 328.15 K, using sunflower oils, 91% extraction and 81% stripping of platinum(IV) were attained. The use of HFSLM impregnated by non-toxic diluents can be a promising green technology over HFSLM impregnated by toxic diluents. The thermodynamic parameters for sunflower oils such as  $\Delta G$ ,  $\Delta H$  and  $\Delta S$  were calculated and found to be -37.822 kJ/mol, 98.8035 kJ/mol and 0.2003 kJ/mol K, respectively. The calculated results demonstrated that the separation process of platinum(IV) was endothermic and spontaneous. The activation energy ( $E_a$ ) of the platinum(IV) extraction reaction was 1.673 kJ/mol. This indicated that the diffusion of complex species across the liquid membrane was the mass transfer-controlling step for the separation of platinum(IV) via HFSLM. Finally, a modified

Apelblat equation was applied to explain the transport of platinum(IV) in terms of efficiency of extraction across HFSLM. The calculated results from the model were in good agreement with the experimental data at 1.28% RMSD.

The optimized operating conditions for the separation of palladium(II) from the flexible printed circuit board wastewater are concluded below in **Table 6.1.**, and for the separation of platinum(IV) from gold refining wastewater are concluded below in **Table 6.2.**



**Table 6.1** The optimized operating conditions for the extraction and stripping of palladium(II) from the flexible printed circuit board wastewater

Parameters	
1. pH of feed solution	2
2. Types of extractants	LIX 84-I
3. Concentration of extractants	5 % (v/v)
4. Types of organic solvents	kerosene
5. Types of stripping solution	NH <sub>2</sub> CSNH <sub>2</sub> in HCl
6. Concentration of stripping solution	0.8 M
7. Operating time	60 min
8. Operating temperature	323 K
9. Stability of the liquid membrane	350 min

**Table 6.2** The optimized operating conditions for the extraction and stripping of platinum(IV) from gold refining wastewater

Parameters	
1. pH of feed solution	2
2. Types of extractants	Aliquat 336
3. Concentration of extractants	10 % (v/v)
4. Types of organic solvents	kerosene
5. Types of natural solvents	sunflower oil
6. Types of stripping solution	$\text{NH}_2\text{CSNH}_2$ in HCl
7. Concentration of stripping solution	0.8 M
8. Operating time	30 min
9. Operating temperature	303 K

## 6.2 Limitation of the research

Although the HFSLM system can be applied in several industrial applications and analytical fields for separation of metal ions, the major drawbacks of HFSLM are fouling and mechanical stability of the support. In spite of its number of uses, HFSLM, with its potential such as high selectivity and effective separation of desired organic compounds, has some disadvantages which are encountered whilst scaling up its operation on an industrial scale. A major concern of the rare applications of HFSLM when used in industry is attributed to the membrane stability

in terms of long time performance. This leads to the reduction of solute flux and membrane selectivity. Thus, so far, these major drawbacks make the HFSLM not often used in large-scale industry.

### 6.3 Recommendations for future studies

1. wastewater must be pre-treated to prevent fouling in the HFSLM system.
2. Other wastewater sources of palladium(II) and platinum(IV) such as jewelry, auto-catalyst and electronics should be applied to the HFSLM system.
3. Study on the stability of the HFSLM should be widely undertaken for scaling

### REFERENCES

- [1] V.C. Adya, A. Sengupta, S. Ansari, P.K. Mohapatra, M.K. Bhide, S.V. Godbole, J Radioanal Nucl Ch, 295 (2013) 1023-1028.
- [2] N. Leepipatpiboon, U. Pancharoen, P. Ramakul, Korean J Chem Eng, 30 (2013) 194-200.
- [3] P.V. Vernekar, Y.D. Jagdale, A.W. Patwardhan, A.V. Patwardhan, S.A. Ansari, P.K. Mohapatra, V.K. Manchanda, Chem Eng Res Des, 91 (2013) 141-157.
- [4] K. Wongkaew, T. Wannachod, V. Mohdee, U. Pancharoen, A. Arpornwichanop, A.W. Lothongkum, J Ind Eng Chem, 42 (2016) 23-35.
- [5] K. Wongkaew, N. Sunsandee, U. Pancharoen, K. Nootong, P. Ramakul, J Ind Eng Chem, 22 (2015) 217-228.
- [6] K. Wongkaew, U. Paricharoen, S. Phatanasri, N. Leepipatpiboon, A.W. Lothongkum, J Ind Eng Chem, 21 (2015) 212-220.
- [7] A. Mtibe, T.A.M. Msagati, A.K. Mishra, B.B. Mamba, Phys. Chem. Earth., 50-52 (2012) 239-242.
- [8] Y. Liu, B. Shi, Sep. Purif. Technol., 65 (2009) 233-242.
- [9] S. Suren, N. Sunsandee, M. Stolcova, M. Hronec, N. Leepipatpiboon, U. Pancharoen, S. Kheawhom, Fluid Phase Equilib, 360 (2013) 332-337.
- [10] N. Sunsandee, P. Ramakul, N. Thamphiphit, U. Pancharoen, N. Leepipatpiboon, Chem. Eng. J., 209 (2012) 201-214.
- [11] N. Sunsandee, U. Pancharoen, P. Rashatasakhon, P. Ramakul, N. Leepipatpiboon, Separ Sci Technol, 48 (2013) 2363-2371.
- [12] K. Wongkaew, V. Mohdee, U. Pancharoen, A. Arpornwichanop, A.W. Lothongkum, J Ind Eng Chem , 54 (2017) 278-289.





## APPENDIX A

### A.1 Physical characteristics of the hollow fiber module

The HFSLM equipment used for the separation of the target metal ions is comprised of a hollow fiber module, gear pumps, rotameters, variable flow rate controllers and pressure gauges. The hollow fiber module is composed of Celgard®x-40 microporous fibers intertwined into the fabric and wrapped around a central-tube feeder to supply the shell-side fluid. The number of hollow fibers in the contactor was confirmed by supplier as shown in **Fig.A.1**. Other physical characteristics of this module are shown in **Table A.1**.

**Fig.A. 1** Email from supplier to confirm the number of hollow fibers in the contactor

Subject: RE: [Liqui-Cel](#) Contact Form  
> Date: Mon, 13 Dec 2010 16:08:50 -0500  
> From: [fred.wiesler@membranafiltration.com](mailto:fred.wiesler@membranafiltration.com)  
>  
> [Liqui-Cel](#) Extra-flow 2.5 in x 8 in: details of pore size, porosity and number of hollow fibers:  
>  
> Answer for porosity depends on the type of hollow fiber membrane used in the contactor. It could be X40 or X50 membrane.  
> Porosity (nominal): 25% for X40, 40% for X50  
> Pore size (nominal): 0.03 micron  
> Number of hollow fibers in contactor (nominal): 35,000

**Table A. 1** Physical characteristics of the hollow fiber module.

Characteristics	Descriptions
Material	polypropylene
Number of fibers	35,000
Fiber inside diameter (cm)	0.024
Fiber outside diameter (cm)	0.03
Effective length (cm)	19.8
Surface area (cm <sup>2</sup> )	1.4 x 10 <sup>4</sup>
Area per unit volume (cm <sup>2</sup> /cm <sup>3</sup> )	29.3
Membrane porosity	25%
Average pore size (cm)	3x10 <sup>-6</sup>
Membrane tortuosity	2.6
Module diameter (cm)	6.3
Module length (cm)	20.3
Operating temperature (K)	273 – 333

## A.2 The efficiency of extraction and stripping of target ions

The concentration of target ions in the aqueous solutions was determined before and after extraction for calculating the percents of extraction and stripping by using the inductively coupled plasma optical emission spectrometer (ICP–OES) (model JY 2000–2; HORIBA Jobin Yvon, France). The concentration of metal ions in liquid membrane phase was decreased by mass balance. For example, the concentration of platinum(IV) in gold refining wastewater is shown in **Table A. 2**. In

order to confirm the efficiency and reliability, each analysis was conducted in three duplicates.

The percentage of target ions extraction was defined as:

$$\% \text{Extraction} = \frac{[M]_{f,in} - [M]_{f,out}}{[M]_{f,in}} \times 100 \quad (\text{A.1})$$

where  $[M]_{f,in}$  is the concentration of the target ions in feed solution, and  $[M]_{f,out}$  is the concentration of target ions at any time.

The percentage of stripping of the target ions was calculated by:

$$\% \text{Stripping} = \frac{[M]_{s,out}}{[M]_{f,in}} \times 100 \quad (\text{A.2})$$

where  $[M]_{s,out}$  is the outlet concentration of the target ions in the stripping solution (ppm).

**Table A. 2** The concentration of platinum(IV) in gold refining wastewater.

Ti me	$[M]_{f,in}$ , ppm	$[M]_{f,out}$ , ppm	$[M]_{s,out}$ ppm	CM	%E	%S
5	4.91	4.59	0.17	0.32	6.46	3.48
10	4.91	3.15	0.98	1.76	35.92	20.01
15	4.91	1.54	1.96	3.37	68.68	40.00
20	4.91	0.78	2.86	4.13	84.10	58.33
25	4.91	0.44	3.64	4.47	90.99	74.21
30	4.91	0.41	4.33	4.50	91.61	88.16

Note: %Stripping (%S); %Extraction (%E); Complex species (CM)

## APPENDIX B

### B.1 Oral presentations

[1] K. Wongkaew, N. Leepipatpiboon and U.Pancharoen, State of the Art Hollow Fiber Supported Liquid Membrane on Pd (II) Separation from Wastewater Using Alamine 336, 2014 4th International Conference on Chemistry and Chemical Process (ICCCP 2014), Singapore.

[2] K. Wongkaew and U.Pancharoen, Simultaneous extraction and stripping of Pd(II) and Pt(IV) in chloride media via hollow fiber supported liquid membrane impregnated with Alamine 336 and Aliquat 336, RGJ-Ph.D. Congress XV, Thailand

[3] K. Wongkaew and U.Pancharoen, Simultaneous Extraction and Stripping of Palladium in Chloride Media via a Hollow Fiber Supported Liquid Membrane Impregnated with Tri-n-Octylamine (Alamine 336), International conference on environmental sciences, Dubai.

### B.2 Research in foreign laboratory

**January, 2015 – January, 2016,** The Laboratory Catalyzed Processes, Department of Organic Technology, Faculty of Chemical and Food Technology, Slovak University of Technology in Bratislava, Slovak Republic with Professor D.Sc. Ing. Milan Hronec.

### **B.3. Scholarships**

**2009** Scholarship form the Thailand Research Fund though the Royal Golden Jubilee Ph.D. Program (Grant No.PHD/0297/2550)

### **B.4 Peer reviewed journal publications published**

[1] K. Wongkaew, K. Fulajtárova, M. Hronec, V. Mohdee, U. Pancharoen, K. Nootong, Measurement of the solubility of the salt of 2-mercaptobenzothiazole with cyclohexylamine and tert-butylamine in various solvents at low temperatures: Models and thermodynamic parameters, *Fluid Phase Equilibria*, 434 (2017) 141-151.

[2] K. Wongkaew, T. Wannachod, V. Mohdee, U. Pancharoen, A. Arpornwichanop, A.W. Lothongkum, Mass transfer resistance and response surface methodology for separation of platinum (IV) across hollow fiber supported liquid membrane, *Journal of Industrial and Engineering Chemistry*, 42 (2016) 23-35.

[3] K. Wongkaew, N. Sunsandee, U. Pancharoen, K. Nootong, P. Ramakul, Purification of Sn(IV) and recovery of Pd(II) from flexible printed circuit board industry wastewater via HFSLM: Temperature effect investigation, *Journal of Industrial and Engineering Chemistry*, 22 (2015) 217-228.

- [4] K. Wongkaew, U. Paricharoen, S. Phatanasri, N. Leepipatpiboon, A.W. Lothongkum, Effect of diluent polarity on membrane stability in the separation of trace Pd(II) from wastewater by HFSLM using LIX84-I, *Journal of Industrial and Engineering Chemistry*, 21 (2015) 212-220.
- [5] T. Pirom, K. Wongkaew, T. Wannachod, U. Pancharoen, N. Leepipatpiboon, Separation of Co(II) and Mn(II) from sulphate media via a HFSLM: Reaction flux model and experimental verification, *Journal of Industrial and Engineering Chemistry*, 20 (2014) 1532-1541.
- [6] S. Chaturabul, K. Wongkaew, U. Pancharoen, Selective Transport of Palladium through a Hollow Fiber Supported Liquid Membrane and Prediction Model Based on Reaction Flux, *Sep Sci Technol*, 48 (2013) 93-104.
- [7] K. Wongkaew, T. Soták, M. Hronec, U. Pancharoen and A.Arpornwichanop, Effect of inorganic salts and organic solvents on extraction of maleic acid from aqueous solution: model and thermodynamics parameters, *Fluid Phase Equilibria*, in-press(2017).
- [8] K. Wongkaew, T. Wannachod, U.Pancharoen, A. Arpornwichanop, A. W.Lothonkumb, Separation of platinum (IV) across hollow fiber supported liquid membrane using non-toxic diluents: mass transfer and thermodynamics, *Journal of Industrial and Engineering Chemistry*, *J Ind Eng Chem*,54 (2017) 278-289.



**VITA**

Name: Krirkratthawit Wongkaew

Birthdate and place: May 16, 1985; Sisaket, Thailand.

Education:

2009-2016: D.Eng in Chemical Engineering, Department of Chemical Engineering; Faculty of Engineering; Chulalongkorn University, Bangkok, Thailand.

2005-2009: B.Eng in Chemical and Biological Engineering, Department of Chemical Engineering; Faculty of Engineering, Ubon ratchathani University, Ubon ratchathani, Thailand.

