

CHAPTER III



EXPERIMENTAL PROCEDURE

3.1 Materials

3.1.1 Polymer matrix

Acrylonitrile-butadiene-styrene (ABS) consisted of 24% acrylonitrile, 21% butadiene, and 55% styrene was supplied by IRPC Co., Ltd. (Thailand) in yellowish pellets form.

3.1.2 Organomontmorillonite (OMT)

Organomontmorillonite clay with a cation exchange capacity of 71 meq/100g was prepared by modifying montmorillonite with dioctadecyl dimethyl ammonium chloride in order to solve the incompatible problem on the surface between ABS and layer silicate of montmorillonite clay.

3.1.3 Silane coupling agents

Vinyltrimethoxysilane (VTMO) and 3-aminopropyltrimethoxysilane (AMMO) used as surface modifier for silica were supplied by JJ-degussa Chemicals (Thailand) Co., Ltd and Connell Bros. (Thailand) Co., Ltd., respectively. They are colorless, low viscosity liquid. They can act as an efficient adhesion promoter for various mineral filled polymers and improve the compatibility of fillers with polymers, leading to a better dispersibility.

3.1.4 Catalysts

Maleic acid was also supplied by Siam Chemical Co., Ltd. (Thailand). It is an organic compound that is a dicarboxylic acid (molecule with two carboxyl groups). The molecule consists of an ethylene group flanked by two carboxylic acid groups. It is the less stable molecule: e.g., the difference in heat of combustion is 22.7 KJ/mol. It is soluble in water and its melting point is 130 - 139°C. In addition, triethylenetetramine (TETA) was also purchased from Fluka. This oily liquid is colorless but, like many amines, assumes a yellowish color due

to impurities resulting from air-oxidation. It is soluble polar solvents and exhibits the reactivity of typical for triethanolamine.

3.1.5 Solvent



Triethanolamine (TEA) used as reactant was purchased from Ajax Finechem Nuplex Industries (Australia) Pty., Ltd., is an organic chemical compound which is both a tertiary amine and a tri-alcohol. It acts as a weak base, hygroscopic liquid with an ammonia aroma, and soluble in chloroform, water, and alcohol. In addition, its boiling point is at 335°C. For ethylene glycol (EG) used as solvent was purchased from Ajax Finechem Nuplex Industries (Australia) Pty., Ltd.

3.1.6 Commercial silica

Commercial silica (SiO_2) was purchased from Ajax Finechem Nuplex Industries (Australia) Pty., Ltd. It's white fine powder with 99.5% of purity.

The chemical structure for each chemical used in this research was summarized in Table 3.1

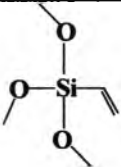
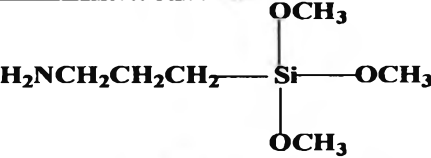
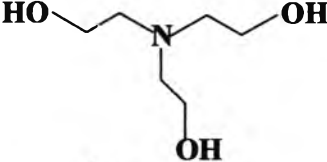
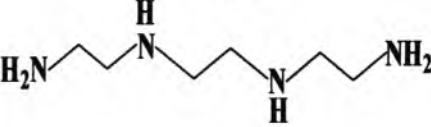
Table 3.1 Chemicals used in this research

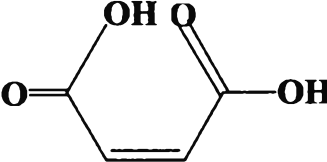
Name	Structure/Formula	Function
Acrylonitrile-butadiene-styrene (ABS)	$(C_8H_8.C_4H_6.C_3H_3N)_n$	matrix
Vinyltrimethoxysilane (VTMO)		coupling agent
3-Aminopropyltrimethoxysilane (AMMO)		coupling agent
Triethanolamine (TEA)		reactant
Triethylenetetramine (TETA)		catalyst
Ethylene glycol (EG)		solvent
Maleic acid (MA)		catalyst
Silica (SiO ₂)	$O=Si=O$	filler

3.2 Instruments

Table 3.2 Experimental instruments

Instruments	Model	Manufacturer
Two roll mill	Scientific	Labtech Engineering, USA
Compression molding machine	Scientific	Labtech Engineering, USA
Internal Mixer	MX500-D75L90	Charoen Tut, Thailand
Twin-screw extruder	TSE-16-TC	Thermo PRISM, UK
Differential scanning calorimeter	DSC1/156/700/GC10	Mettler-Toledo, Switzerland
Thermogravimetric analyzer	TGA/SDTA851 ^e	Mettler-Toledo, Switzerland
Transmission electron microscope	JEM-100SX	JEOL, Japan
Scanning electron microscope	JSM-5410LV	JEOL, Japan
Fourier transform infrared spectroscopy	Spectrum I	Perkin Elmer, USA
CHNS/O analyzer	PE2400 Series II	Perkin Elmer, USA
X-ray diffractometer	PW 3710	Philips Analytical Instrument, USA
Limiting oxygen index tester	PL	Stanton Redcroft, UK
X-ray fluorescence	ED2000	Oxford, UK
Universal testing machine	LR100k	LLOYD, UK
Izod impact tester	GT-7045-MD	Gotech, Taiwan
Surface area analyzer	ASAP2020	Micromeritics, USA
NMR Spectrometer	DPX-300	Bruker Biospin, Germany
Laser particle size analyzer	Mastersizer S	MALVERN

3.3 Experimental Procedure

The flow chart of the entire research is shown in Figure 3.1.

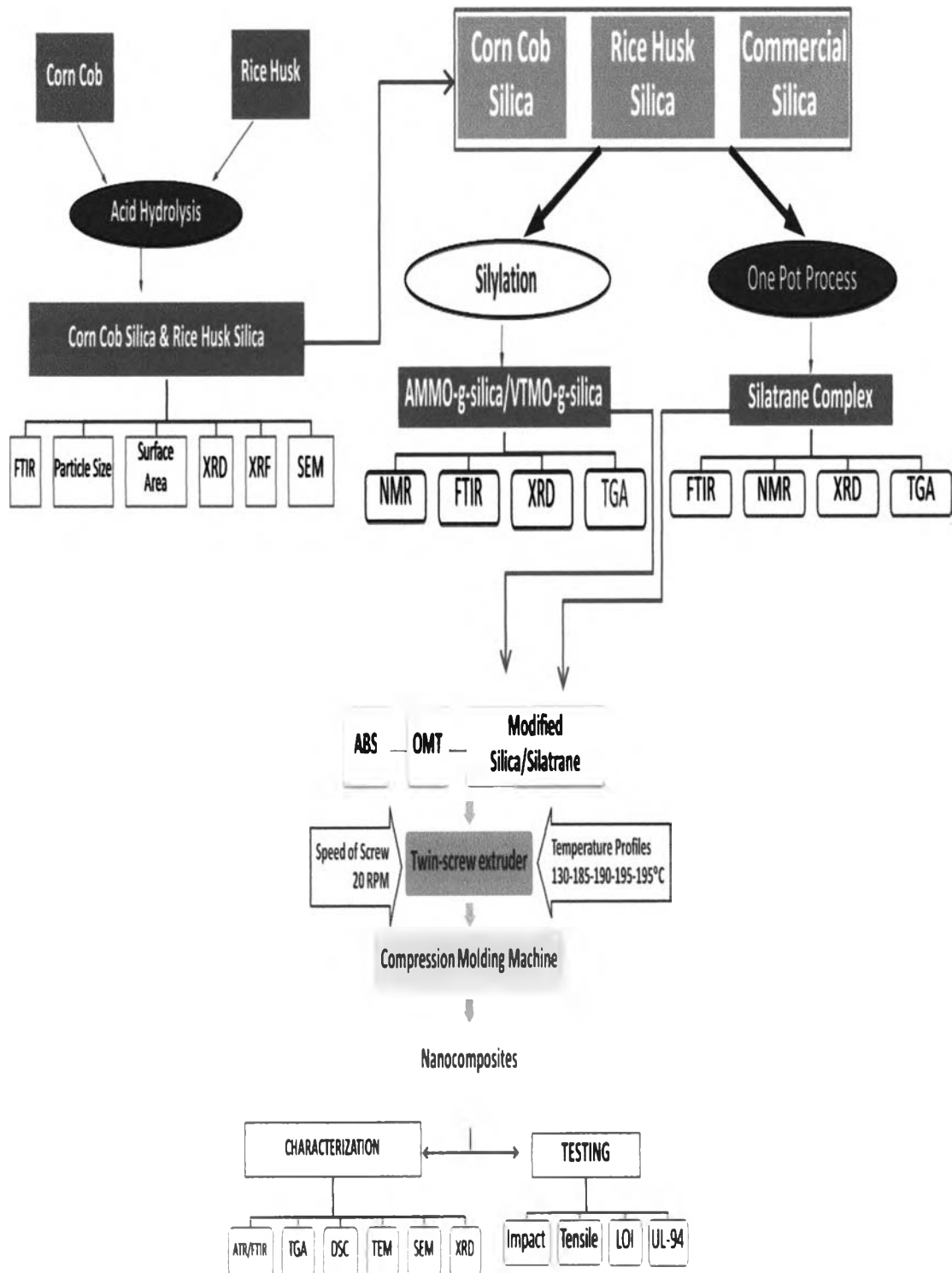

Figure 3.1 Flow chart of experimental process

3.3.1 Preparation of silica from rice husk and corn cob ash

High purity silica was prepared from corn cob and rice husk obtained from local mill using acid hydrolysis [19, 30-32]. The corn cob and rice husk were mixed with 0.4M HCl in the ratio of 100g corn cob or rice husk per 1 litre of acid and heated at 105°C for 3 hrs until the color of corn cob and rice husk changed from yellow to dark brown. Then, the samples were washed repeatedly to remove acid using tap water until pH was neutral. After that, they were dried overnight in an oven at 115°C. Next, the treated corn cob and rice husk were burnt in a furnace under controlled temperature at 700°C for 3 hrs and 4 hrs for rice husk and corn cob, respectively. The obtained silica in the form of white ash was ground by a grinder to reduce its particle size and sieved at 200 meshes.

3.3.2 Preparation of VTMO/AMMO grafted on silica

Vinyltrimethoxysilane (VTMO) and 3-aminopropyltrimethoxysilane (AMMO) were used as silane coupling agents for modifying surface of silica. The silica extracted from rice husk and corn cob was converted to hydroxylated silica by washing with 0.06M HCl as shown in equation 3.1. Then, they were vacuum filtered, washed with distilled water until pH was neutral, and dried in an oven at 110°C for 24 hrs. After that, they were mixed with VTMO/AMMO and acetone by refluxing [33-35]. Then, 1.5 g maleic acid and 10 ml water were added as a catalyst at a boiling point of acetone and reflux for 2 hrs. Next, they were filtered with acetone. Finally, the VTMO/AMMO-g-silica obtained was dried in an oven at 110°C for 24 hrs.

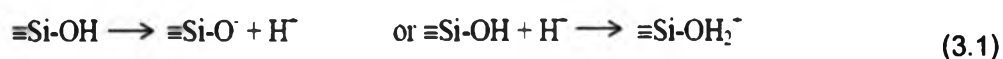

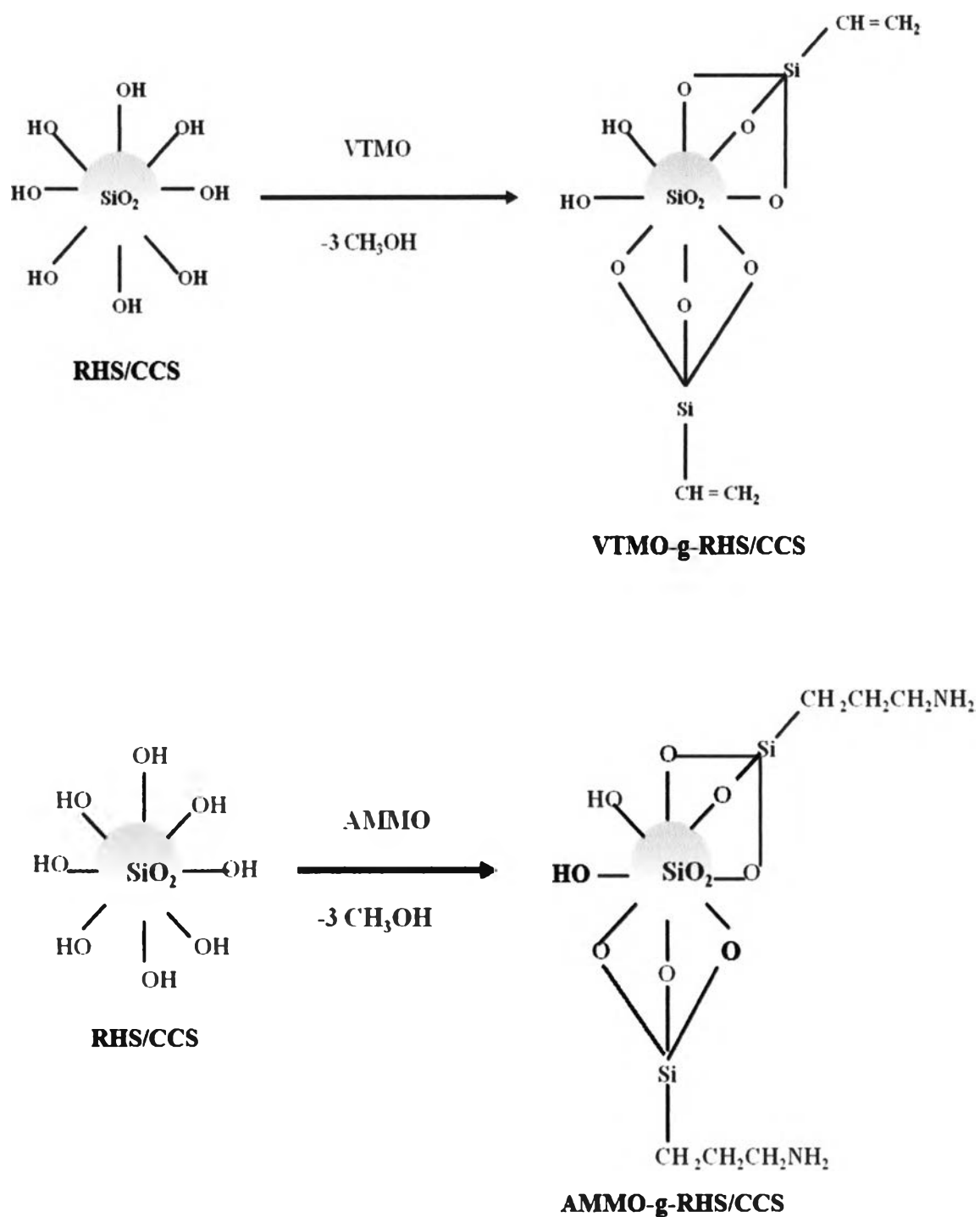

Figure 3.2 Schematic of VTMO/AMMO grafted on silica surface

3.3.3 Preparation of silatrane complex

Silatrane complex was synthesized by one pot process [7-9]. The mixture of silica (SiO₂), ethylene glycol, and triethanolamine was refluxed under nitrogen in a thermostat oil bath. Triethylenetetramine was used as a catalyst in this process. When

the temperature in oil bath reached up to 200°C, the reaction was initiated and it was then maintain at this temperature to initiate until the reaction mixture turned clear, which indicating that the reaction was completed. Then, the ethylene glycol was removed by vacuum distillation. The liquid silatrane products were precipitated by stirring with acetonitrile to remove excess triethanolamine. The silatrane obtained was dried in a vacuum oven at 80°C for 12 hrs.

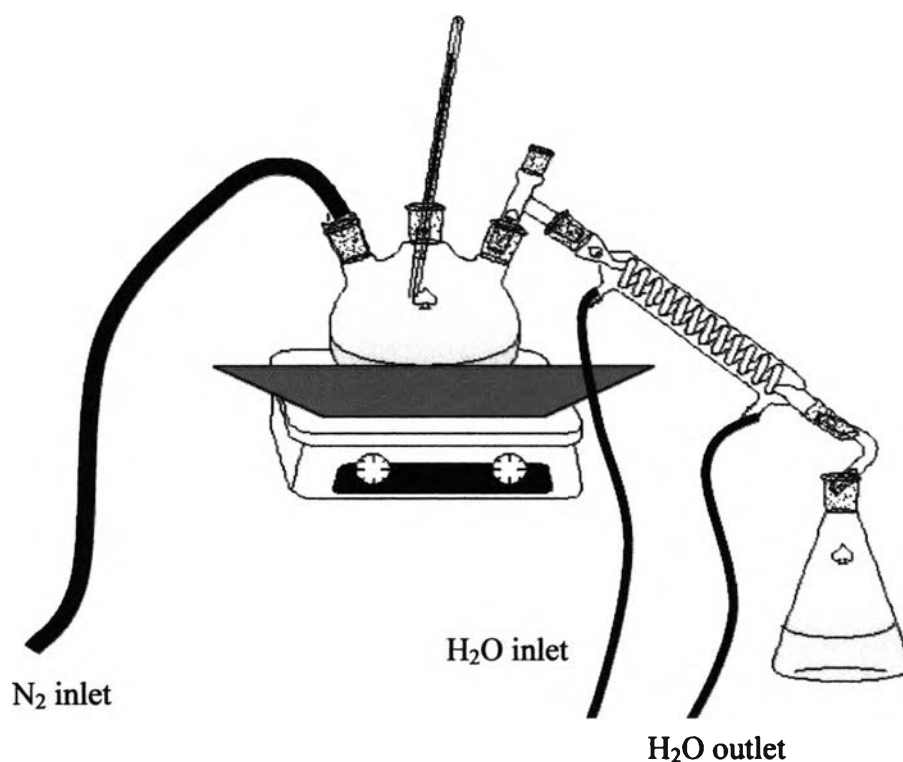

Figure 3.3 Experimental apparatus of silatrane synthesis

3.3.4 Preparation of ABS nanocomposites

3.3.4.1 Preparation of ABS/OMT nanocomposites

ABS and OMT were mixed at various ratios of OMT contents (1, 3, 5, 7, and 9 wt% based on ABS) by melt blending technique using co-rotating twin-screw extruder with L/D 24:1 at rotational speed of 20 rpm. The temperature profiles of the barrel were set at 130-185-190-195-195°C from hopper to die for all the samples. The extrudate samples were pressed at 170°C by compression molding machine and then cooled to room temperature to obtain the composite sheets. The composite sheets were prepared with different thickness and shape according to the test methods.

3.3.4.2 Preparation of ABS/OMT/silane-g-silica nanocomposites

The prepared VTMO/AMMO-g-silica was mechanically mixed with ABS and OMT at different concentrations of modified silica contents (5, 10, 15, 20, and 25 wt% based on ABS) by melt blending technique using co-rotating twin-screw extruder with L/D 24:1 at rotational speed of 20 rpm. The temperature profiles of the barrel were set at 130-185-190-195-195°C from hopper to die for all the samples. The extrudate samples were pressed at 170°C by compression molding machine and then cooled to room temperature to obtain the composite sheets. The composite sheets will be prepared with different thickness and shape according to the test methods.

3.3.4.3 Preparation of ABS/OMT/silane-g-silica/silatrane nanocomposites

The prepared silatrane was mechanically mixed with ABS, OMT, and VTMO/AMMO-g-silica at different ratios of silatrane contents (0, 5, and 10 wt% based on ABS) by melt blending technique using internal mixer at speed of 40 rpm for 10 minutes. The temperature was set at 180°C. The mixed samples were pressed at 170°C by compression molding machine and then cooled to room temperature to obtain the composite sheets. The composite sheets were prepared with different thickness and shape according to the test methods.

All the ABS nanocomposites samples prepared were summarized in Table 3.3

Table 3.3 Formulations used in this study

SAMPLES	PERCENT OF LOADING
ABS	100/0
ABS/OMT/modified silica/nanocomposites	(100-a-c), (a; a=5, 10, 15, 20, 25)
ABS/OMT/silatrane nanocomposites	(100-b-c), (b; b=5, 10, 15, 20, 25)
ABS/OMT nanocomposites	(100-c), (c; c=1, 3, 5, 7, 9)
ABS/OMT/modified silica/silatrane/nanocomposites	(100-a-b-c)

***Remarks: a = modified silica (three types: commercial silica, rice husk silica, corn cob silica), b= silatrane (three types: Silatrane, rice husk silatrane, corn cob silatrane), c= organomontmorillonite (OMT)

3.4 Characterization and Testing

3.4.1 Characterization of rice husk silica, corn cob silica, and commercial silica

3.4.1.1 Particle size

The particle size of silica from rice husk and corn cob was determined using laser particle size analyzer (MALVERN). The measurement based on the scattering of the laser beam. To prevent aggregation, n-hexane was used as dispersing agent for silica.

3.4.1.2 Surface morphology

The surface morphology of silica was investigated under a JEOL JSM-5410LV scanning electron microscopy (SEM). The SEM is particularly useful in materials analysis for the examination of fractured surfaces of sample. The cryogenic fractured surfaces were obtained by immersing the unbroken samples into liquid nitrogen for several minutes and breaking them with the tap of a hammer, the fracture surfaces were gold coated before SEM examination.

3.4.1.3 Functional group

The functional group of silica was investigated by fourier transform infrared spectrometer, Spectrum I, Perkin Elmer, with a number of scan of 16 and a resolution of 4 cm^{-1} . Samples were prepared by grinding in a mortar and pestle, then they were mixed thoroughly with potassium bromide powder with a ratio of 1:100 and pressed hydraulically to get a thin film of substance. After that, they were placed in the infrared beam position to detect spectra.

3.4.1.4 Chemical composition for elemental analysis

The chemical composition for elemental analysis of rice husk ash and corn cob ash was identified by using X-ray fluorescence (XRF). The powder of sample was mixed with 10% boric acid and burned at 1000°C . Then, it was pressed by hydrolic pressure to get a ring shape. After that, it was detected the wavelength emitted from the sample.

3.4.1.5 Surface area

Specific Surface Area Measurement Gas adsorption technique, described by Brunauer-Emmett-Teller (BET) gas adsorption theory, was used for measuring specific surface area of corn cob silica, rice husk silica, and commercial silica. The samples were degassed at high temperature for 1 hour before testing in order to get rid of moisture. The specific surface area of all the samples was calculated by using the relationship between applied pressure and volume of gas forced into the sample using BET method.

3.4.1.6 Elemental analysis

The percentage of carbon, hydrogen, and nitrogen atoms was determined by CHNS/O Analyzer. Gaseous products were fed by pyrolysis in high purity oxygen and were chromatographically separated by frontal analysis with quantitatively detected by thermal conductivity detector. The temperature in combustion step and reduction step was 925°C and 640°C, respectively.

3.4.2 Characterization of silatrane and modified silica with silane coupling agent

3.4.2.1 Chemical structure

The chemical structure of silatrane and the percentage of silane grafting on silica surface were characterized by Silicon Nuclear Magnetic Resonance (^{29}Si NMR) Spectrometer, AVANCE Digital DPX-300, Bruker Biospin. All powder samples were characterized at room temperature ($20 \pm 1^\circ\text{C}$) with solid state ^{29}Si CP/MAS NMR. The spectra were recorded at a frequency of 60 MHz. The spectral parameters used were 1,600 numbers of scan (NS), relaxation delay of 6 s, spin rate of 5 kHz, and spectral size 4 K with 2 K time domain size.

3.4.2.2 Functional group

The functional group of silatrane synthesized from rice husk silica, corn cob silica, and commercial silica was characterized by Fourier Transform Infrared (FTIR) spectrometer, Spectrum I, Perkin Elmer, with a number of scan of 16 and a resolution of 4 cm^{-1} . Samples were prepared by grinding in a mortar and

pestle, then they were mixed thoroughly with potassium bromide powder with a ratio of 1:100 and pressed hydraulically to get a thin film of substance. After that, they were placed in the infrared beam position to detect spectra.

3.4.2.3 Crystal structure

The crystal structure of silatrane and silane grafted on rice husk silica, corn cob silica and commercial silica was investigated by X-ray diffractometer (XRD), PW 3710 Philip Analytical Instrument.

3.4.2.4 Particle size

The particle size of silatrane that synthesized from rice husk silica, corn cob silica, and commercial silica was determined using laser particle size analyzer (MALVERN).

3.4.2.5 Specific surface

The specific surface area of silatrane that synthesized from rice husk silica, corn cob silica, and commercial silica were determined using surface area analyzer.

3.4.3 Characterization and testing of ABS nanocomposites

The crystal structure of montmorillonite in the ABS was evaluated by X-ray diffractometer (XRD, X-ray diffractometer), scanning electron microscopy (SEM), and transmission electron microscopy (TEM).

3.4.3.1 Functional group

The functional group of ABS nanocomposites was characterized by Fourier Transform Infrared (FTIR) spectrometer, Spectrum I, Perkin Elmer, with a number of scan of 16 and a resolution of 4 cm^{-1} by using ATR mode.

3.4.3.2 Crystal structure

The x-ray diffraction (XRD) patterns was investigated using a PW 3710 Philip Analytical Instrument. The sample was ground with a mortar and pestle,

then packed in a glass specimen holder before running in the diffractometer. Scans were measured in the range 2θ of 2 to 40° at continuous scan speed with time per step of 1 sec, using Cu- K_α radiation operated at 40 KV of generator tension and 30 mA of generator current.

3.4.3.3 Dispersibility

The dispersibility of samples was investigated by transmission electron microscopy (TEM) analysis. The specimens were cut by an ultramicrotome with a diamond knife. They have to be thin enough to allow an electron beam to be transmitted through. They are placed between the condenser and objective lenses. TEM images were obtained by Oxford connected to JEOL JEM-100SX (acceleration voltage 100kV).

3.4.3.4 Morphology

The fractured surface of ABS nanocomposites was investigated under a JEOL JSM-5410LV scanning electron microscopy (SEM). For EDS analysis was monitored by Link ISIS series 300, Oxford connected to JSM 5800 LV, JEOL. The scanning electron microscopy (SEM) is an instrument that impinges a beam of electrons in a pinpointed spot on the surface of a target specimen and collects and displays the electronic signals given off by the target material. The SEM is particularly useful in materials analysis for the examination of fractured surfaces of sample. The cryogenic fractured surfaces were obtained by immersing the unbroken samples into liquid nitrogen for several minutes and breaking them with the tap of a hammer, the fracture surfaces were gold coated before SEM examination.

3.4.4 Thermal Properties

The thermal properties of pure ABS and its nanocomposites were investigated by thermogravimetric analysis (TGA) and differential scanning calorimetry (DSC). The thermal stability and temperature decomposition (T_d) of approximately 3-4 mg of ABS nanocomposites were determined by using a METTLER TOLEDO TGA/SDTA851e

Thermogravimetric analyzer under N_2 atmosphere at a heating rate of $20^\circ C/min$ from 25 to $850^\circ C$. The melting temperature (T_m) and glass transition temperature (T_g) of ABS nanocomposites were investigated by using a METTLER TOLEDO DSC1/156/700/GC10 differential scanning calorimetry under N_2 at a flow rate of 20ml/min and a heating rate of $20^\circ C/min$ from 25 to $200^\circ C$. Alumina crucible was used as a reference material and the sample size was about 10-12 mg.

3.4.5 Flammability Properties

3.4.5.1 The limiting oxygen index (LOI)

The sample with the dimensions of 6.5x70x3 mm (WxLxH) was measured using an LOI instrument of Stanton Redcroft, UK, according to ASTM D2863-91. The sample sheet was clamped vertically and ignited at the top and then burned it with propane and butane. The test was based on the determination of the percentage of oxygen in a gas mixture, which would just sustain the burning of 5 cm length of a sample or within 180 s. The concentration of oxygen gas was then adjusted until the minimum level of oxygen for sustained burning was reached within the limitation of distance or time. The percentage of oxygen was recorded as LOI value. Besides the LOI test, the flammability properties of the nanocomposite samples were also determined by the UL-94 test.

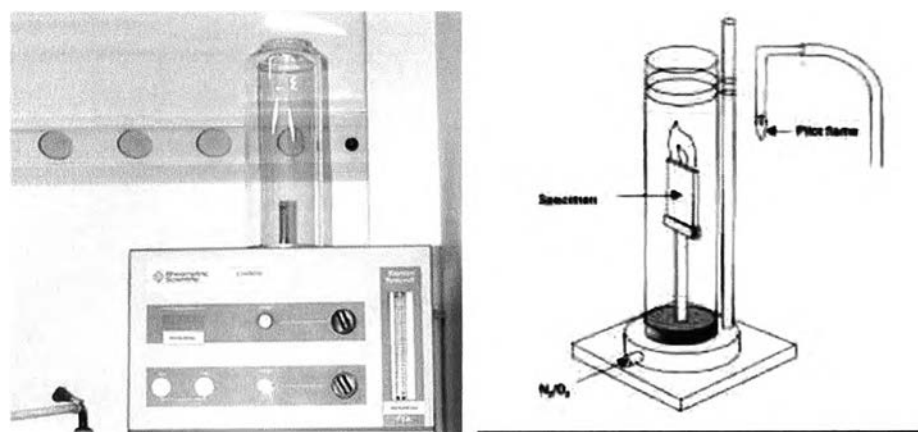

Figure 3.4 LOI test apparatus [1]

3.4.5.2 UL-94 test [1]

The classification of UL-94 test was obtained according to ASTM D635-98, which provided only a qualitative classification of samples. It was divided into two grades, e.g., HB grade and V grade. The test samples were cut into sheet of 13x125x3 mm (WxLxH). The panel test was determined the flame spread of a material that might be exposed to fire. Horizontal test used samples of a defined thickness which must not burn faster than 40 mm/min to reach classification 94HB grade. The horizontal burning rate was calculated using the following equation:

$$V = 60 L/t \quad (3.1)$$

In which:

V= the horizontal burning rate (mm/min)

L= the damaged length (mm)

t= time (s)

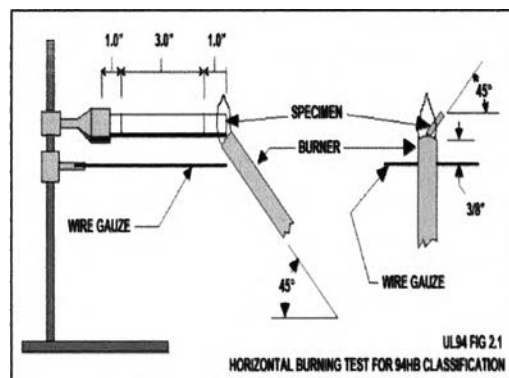

Figure 3.5 Horizontal burning test for UL-94 grade [1]

Table 3.4 The burning rate of UL-94 test

Rating	Test Criteria
UL-94HB	<ul style="list-style-type: none"> Horizontal test uses samples of a defined thickness which must not burn faster than 40 mm/min In all of the above the tests, the samples are extinguished. So, if the sample keeps burning beyond 25 seconds, a horizontal test can be carried out to reach classification 94HB

3.4.6 Mechanical Properties

3.4.6.1 Tensile Strength

The specimens were prepared according to ASTM D 638. A least five specimens of each sample were tested and averaged. Speed of this testing was conducted at 50 mm/min and a gauge length of 25 mm. 10KN load cell was employed for ABS nanocomposites testing.

3.4.6.2 Impact Strength

The specimens were prepared according to ASTM D 256. The width of the specimen was 12.5 mm and the thickness of specimen was 3.0 mm. The notch was V-shape with the radius of 0.25 mm. At least five sample determinations of impact resistance must be made on each experiment. The pendulum with 5.50 J was released from its normal starting position with velocity of 3.46 m/s and note Izod impact resistance value that shown on LCD screen in unit of J/m^2 . Calculate the average Izod impact resistance values of the group of specimens.