

CHAPTER V

TACK TAIL OPERATION IMPROVEMENT

5.1 Introduction¹

5.1.1 Purpose

This process tells how to attach the tail of the flex to the load arm capture using Hysol LD227.

5.1.2 Process Control

- 1) Grounded ESD wrist band must be worn at all times.
- 2) Contamination control measures specified in Engineering Specification.
This includes:
 - Operation to be done in controlled environment
 - Cleanroom gloves to be worn on both hands at all times
 - Cleanroom garments to be worn at all times
- 3) Pre-clean working station & equipment.

¹ Manufacturing Process Document

4) Hysol LD227:

- Adhesive to be stored at -40° F or colder.
- Pot life of adhesive = approximately 2 hours (when thawed). And, do not use adhesive which has become stiff, stringy, difficult to dispense, etc.

5) Verify correct tooling by comparing with Process Flow document.

6) Verify correct ESD controls by comparing with the Process Flow document.

5.2 Work Instruction

5.2.1 Post-Production

1) Apply adhesive to the flex in the area that covers the formed tab. See Figure 5.1.

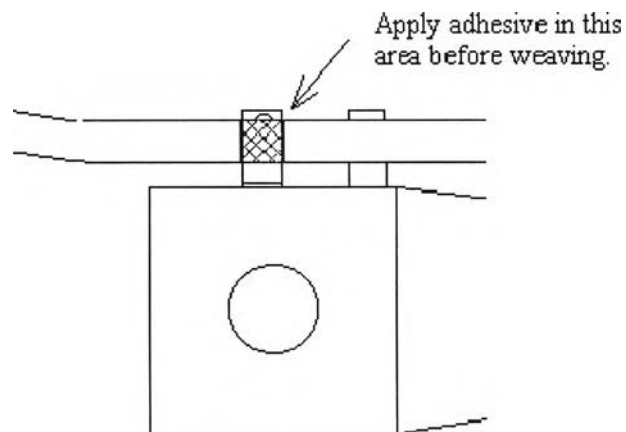

Figure 5.1 Applying adhesive to flex tail in area that covers the formed tab.

2) Weave the flex with a rubber tip pin vise and a round tip tweezers under the formed tab.

3) After tail is weaved, align the flex tail with the edge of the tab by pushing gently on the corner of the flex. See Figure 5.2

4) Stage the HGA for the next operation.

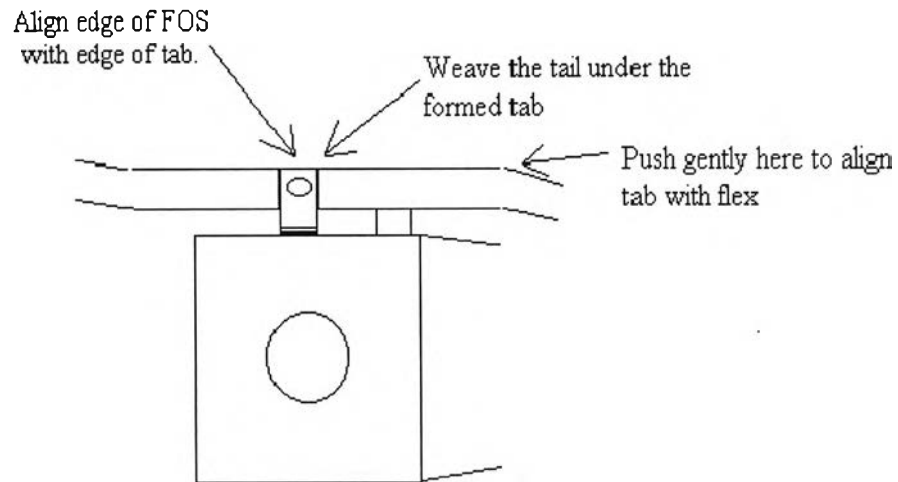

Figure 5.2 Flex tail weave under the formed tab.

5.2.2 Tail Attach Inspection

1) Inspect the tab to insure there is evidence of adhesive on all three sides of the tab. The adhesive must be across at least three traces. If there is not enough adhesive, apply more adhesive until there is evidence of adhesive on all three sides. Gaps are unacceptable.

2) Adhesive on the baseplate is unacceptable.

3) If the adhesive rolls over to the underside of the flex:

- The adhesive rollover must not touch the baseplate.
- Refer to the Product Criteria for adhesive height limit.

4) Maximum allowable height for adhesive above the formed tab: Refer to Product Criteria document. See Figure 5.3.

5) Alignment: DO NOT reject for misalignment. Alignment varies with product.

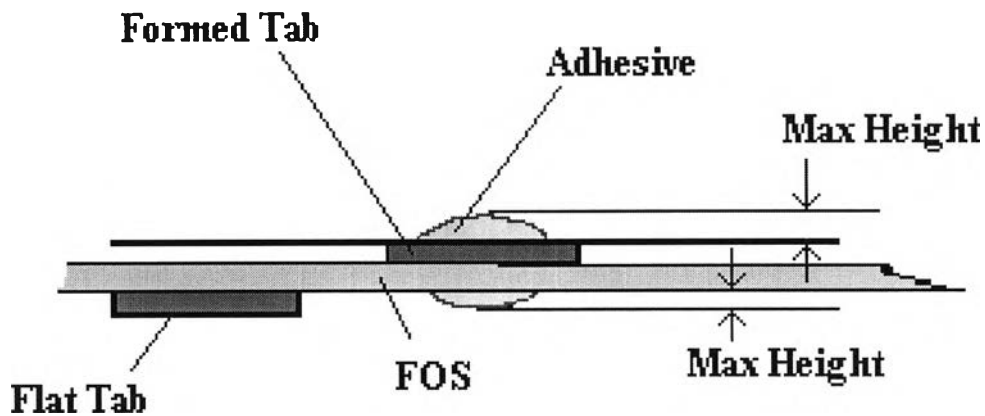

Figure 5.3 Maximum allowance height of adhesive by reference to flat tab height.

5.3 Problem Correction

From reviewing the HGA process flow chart, each operation and inspection were reviewed from the standpoint of *the primary approaches to operation analysis*. A questioning attitude was adopted on how each of these operations influences the time (cost), quality, and output of the product under study. The most important question that should be asked when studying the events on the HGA process flow chart is why. Typical questions that were asked for improving Tack tail operation are why tack tail operation is necessary.

The question Why immediately suggests other questions, including “What”, “How”, “Who”, “Where”, and “When?” Thus, these questions should be asked:

1. What is the purpose of the operation?
2. How can the operation be performed better?

3. Who can best perform the operation?
4. Where could the operation be performed at a lower cost or improved quality?

The examples of above questions might be asked to determine the practicability of the methods improvements indicated. Answering these questions help initiate the elimination, combining, and the simplification of operations.

By answering such questions, the team becomes aware of other questions that may lead to improvement. Ideas seem to generate ideas, and experienced the team always arrives at several possibilities for improvement. And all people in team must keep an open mind so that previous disappointments do not discourage the trial of new ideas.

To improve HGA process from tack tail operation, The purpose of this operation is analyzed with the why question. From studying the process, Tacking tail is to attach the tail to the flex to the load arm capture using Hysol LD227. Cheetah18 is the first product that uses Flex on Suspension. At start up phase there is not tack tail operation too. But this operation was added after getting feed back from drive level in term of resonance problem. Media of Cheetah18 product rotates with speed of 10,000 RPM that is very high compared to many products. But compare to Ultra4, its RPM is only 5,400, therefore, the resonance problem should not occur on this product. Furthermore after continue studying through HSAs process, one idea is proposed to eliminate tack tail operation with the reason that FOS tail will be held in arm slot of E-Block at HSA level and the flying leads will be soldered to PCC. This should be enough strong to hold the tail properly. See Figure 5.4.

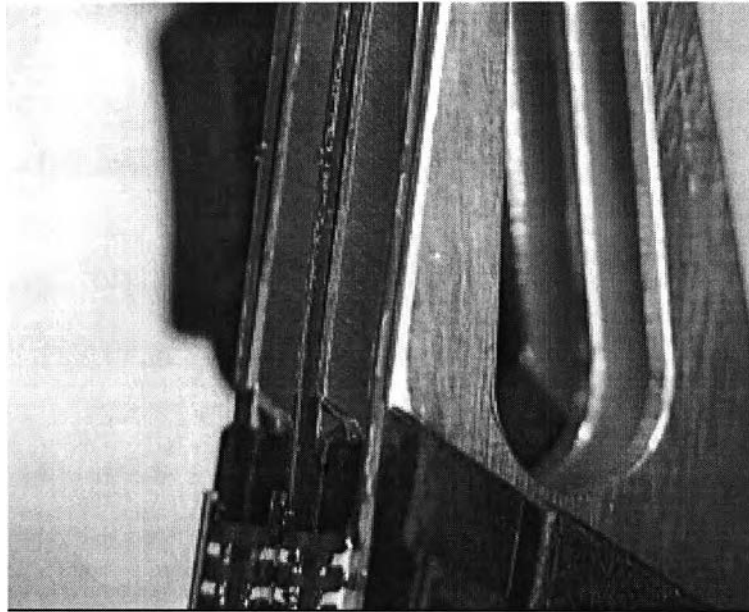

Figure 5.4 Tails of HGA are held in arm slot of E-Block.

5.4 Evaluation Factors and Procedures

5.4.1 Evaluation Factors

1) HGA level

1.1) FOS tail out of suspension capture (Loose tail)

Normally FOS tail will be weave under the tab at base plate of flexure and is attached with adhesive. But the proposal is to eliminate tack tail operation. That means the tail is just weave under the tab and it may loose and out of the tab every time. FOS out of capture will effect aligning tail into the arm slot of E-block and may causes disc scratch issue in disc drive finally.

1.2) Gramload

Gramload is one factor that needs to be evaluated for this proposal. Autogrammer is a machine or tester to adjust gramload of HGA to target limits before fly and electrical testing on HGA process. Every single HGA will be first measured gramload (called Gram_In) and compared to 2.5 ± 0.10 grams called target limits. Any HGA gramload is out target limits, that part will be adjusted by autogrammer. Any HGA gramload is between target limits, such HGA will be passed to next operation. The measurement and adjustment process may be repeated from 1 to 9 times (depended on gramload after adjustment). Final measurement at tenth will be last and compared to HGA gramload spec at $2.5 + 0.4$ grams called gramload specs, any HGA gramload is out of HGA gramload specs will be scrapped.

2) HSA level

- FOS overhang arm slot

As mentioned in HGA level, the FOS tail is not attached to capture with adhesive as normal. Therefore, it may loose and effect to HSAs. FOS tail may be out of arm slot of E-Block and may leads to disc scratch as mentioned before.

3) Drive level

- Drive yield

Due to this proposal is the major change in product design, therefore, drive yield is very concerned with this evaluation. Basically the procedures in qualifying any experiment or evaluation, Drive yield will be brought to use for justify such experiment or evaluation. Normally drive yield contains three parts of drive testing such as ;

- 1) Pre test / STW Yield
- 2) Cert Functional Yield
- 3) Final yield.

The result of those three types of testing between normal group and evaluation group will be compared to qualify such experiment.

5.4.2 Evaluation Procedures

Due to the change in this operation is the major change, the operation was proposed to be eliminated from the current HGA process flow. This change may affect all levels of disc drive assembly process since HGA level through disc drive level. The evaluation, therefore, need to be run through drive level to study effect to all levels.

1) Split wafers

Normally sliders are produced in pattern of wafer that contain many sliders and those wafers will be cut to be sliders at slider level. Each wafer will give different performance. Many times of the evaluations, the different performance between control group and evaluation group came from wafer variation. To eliminate factor from wafer variation, each quad of wafers need to be separated into two groups, the first group for control group and the remaining for evaluation group. Prepare split lot sliders 1,500 pairs of sliders for Control group and 1,500 pairs of sliders for Evaluation group. These numbers are to support building 300 HSAs (300 disc drives) for each group.

2) HGA Build

The propose of this study is tack tail elimination but the FOS tail actually need to be weave under the formed tab. Otherwise tail will not align to the arm slot of E-block at HSA level. To do that, damper operation is assigned to weave FOS tail under capture of flexure. The reasons why the damper operation is selected to do this task are its work elements and excessive capacity. When considering the UPH and capacity of damper operation, they have enough time to do additional task.

Run two split lots through HGA process line. Control separately building those two groups and study performance of those two groups in parts of gramload and FOS tail out of capture. Collect 300 gramload data of each tab of each group by comparing with gramload of raw flexures.

3) HSA Build

Separately build HSAs with both control group and evaluation group. FOS overhang will be monitored at each operation.

4) Disc Drive Build

Control building drive with each group of HSAs. Perform each type of testing.

5.5 Results of the Evaluation

1) HGA level

1.1) Gramload

Gramload data was collected from 250 pairs HGAs per group. Moreover gramload of 250 pairs of incoming flexures were measured to study effect of operation to gramload (Gram_In).

Gramload data were collected and were analyzed through ANOVA in Minitab Software. This analysis is to study difference in mean and standard deviation among raw flexure, HGA with tack tail, and HGA without tack tail. (See Appendix B).

One-way Analysis of Variance (ANOVA)

Analysis of Variance for Gram up

Source	DF	SS	MS	F	P
OPTN_Up	2	2.12779	1.06390	272.78	0.000
Error	747	2.91347	0.00390		
Total	749	5.04126			

Individual 95% CIs For Mean

Based on Pooled StDev

Level	N	Mean	StDev	-----+-----+-----+-----
No_tack	250	2.4976	0.0585	(-*-)
Raw	250	2.5017	0.0544	(-*-)
Tack	250	2.6126	0.0730	(-*-)

Pooled StDev = 0.0625

2.520 2.560 2.600

Analysis of Variance for Gram Dn

Source	DF	SS	MS	F	P
OPTN_Dn	2	1.90929	0.95464	240.20	0.000
Error	747	2.96888	0.00397		
Total	749	4.87817			

Individual 95% CIs For Mean

Based on Pooled StDev

Level	N	Mean	StDev	-----+-----+-----+-----
No_tack	250	2.4983	0.0587	(-*-)
Raw	250	2.5016	0.0551	(-*-)
Tack	250	2.6070	0.0738	(-*-)
				-----+-----+-----+-----
Pooled StDev =	0.0630			2.520 2.555 2.590

From ANOVA, Gramload show the result in same pattern. Analysis of Variance by considering P-Value of each test, the result shows that all P-Value are below 0.05. That means standard deviations of three groups are not equal. ***There is at least one group that its standard deviation does not equal to others.***

Considering individual 95% CIs for Mean, the results show that ***mean of control group (Including Tack tail) is significantly higher than other two groups.*** And its standard deviation is also significantly higher than other two groups. While Mean and standard deviation of Evaluation group shows no significantly different from raw flexure.

Gramload of Evaluation group was compared to gramload target that is set at 2.5 grams with T_test of the mean in Minitab Software.

T-Test of the Mean compare to target (2.5 grams)

Test of mu = 2.50000 vs mu not = 2.50000

Variable	N	Mean	StDev	SE Mean	T	P
No_tack_Up	250	2.49757	0.05847	0.00370	-0.66	0.51

Test of mu = 2.50000 vs mu not = 2.50000

Variable	N	Mean	StDev	SE Mean	T	P
No_tack_Dn	250	2.49833	0.05872	0.00371	-0.45	0.65

Consider from P-Value, they show that all P-Value are above 0.05. That is explained that *Gramload Mean of evaluation group is not significantly different from target*. In other word, it can be explain that gramload of evaluation group is in target and they are not needed to adjust many times. And this benefit may leads to sampling autogram.

1.2) FOS tail is out of suspension capture (Loose tail)

Loosen tail was monitored by FOI operators before those parts were submitted to QC. QC will take 20 samples per lot (280 HGAs per lot) for inspection. The result was shown as below;

Operation	Inspect	Defect	%Defect
FOI	2,719	2	0.11%
QC	200	0	0.00%

FOI operators found 2 units from 2,719 units (0.11%) that their tails are out of formed tabs. This number is acceptable with the reason that this number is very small and they can be easily reworked by weave it under formed tab with tweezers again. However, causes of defect will be found out in parallel.

2) HSA level

- Concern: 2% of FOS out of capture and need to be re-adjusted
- Concern: FOS overhang over baseplate at various operations as data attached.

Before Reflow

Operation	IN	REJ.	% FOS Overhang
Swage	1167	24	2.05
Unload HSA	1167	1	0.08
FOS Preparation	1216	5	0.41

After Reflow

Operation	IN	REJ.	% FOS Overhang
HSA Clean	1230	2	0.16
S.E.T	1153	3	0.29
VMI	1195	5	0.41

Why does the FOS overhang problem only occur at the last head on the E-block (HD_3 for U4-4HD, HD_2 on U4-3HD)?

- The problem found after reflow soldering is 50% of all HSA are not totally seat in arm slot (> 50% of FOS width is raise up from arm slot) when compare to STTH-W HSA. When this condition is combined with improper HSA pick up from HSA tray then the FOS over hang on HD_3 of U4-4HD can occurred. Noted that HD_3 is in the last head when the HSA in the tray. For U4-3HD, the FOS tail of HD_2 can be out of position by improper Comb moving.

Should the operator be instructed to do something different at this E-block location?

- Yes. All of them were alerted on HSA handling both pick up HSA from tray and moving comb. However, better way to minimize the problem is to follow the documented instructions at FOS preparation and Reflow Soldering to make the FOS tail totally seat in arm slot.

During FOS preparation, does operator ensure FOS is weave through the HGA capture?

- Yes. The tail tack operator has responsibility to route the FOS through the HGA capture but the Damper operator was assigned to perform this activity instead on IC cell. (No tail tack operation.) The pre-inspection will be performed again at FOS preparation operation to make sure that FOS is weave through the HGA capture. Noted that the current HGA capture can not protect the FOS moving out from the capture.

Corrective Action Results

	<u>Before Action</u>	<u>After Action</u>
• FOS Over Arm slot 0-25%	20%	75%
• FOS Over Arm slot 25-50%	30%	25%
• FOS Over Arm slot > 50%	50%	0%
• Outgoing Data (FOS Overhang)	270 PPM	0 PPM

The defective rate at OQA was 270 ppm (3 HSA /sample size 11K), 2 HSA (U4_4HD , HD_0 and Hd_3) and 1 HSA (U4_3HD , HD_2). The observation found 50% FOS width out of the E-block arm that should be the cause of FOS out of channel. The effect process was FOS preparation and Reflow soldering that will be control FOS sits in the slot. We are optimize the FOS prepare position to properly sit the FOS in the E-block arm before reflow soldering and start train to operator.

3) Drive level

	<u>Eval Group 4025</u>	<u>Control Group 4064</u>
• STW (Pretest)	96.8%	96.7%
• Cert Functional	89.5%	84.3%
• Final Test	99.19%	100.0%
• Cumm	85.96%	81.48%

SUBJECT SBR 4025 - Eval group HSAs

PRETEST	SBR4025	Total
Total Tested	285	285
Passed	276	276
Failed	9	9
Yield	96.8%	96.8%

Failure Mode	SBR4025	%
RdPCB		0.0%
TI (E1 Log Check)		0.0%
TI (E2 Log Check)		0.0%
2nd Comm Check		0.0%
Proqual		0.0%
Write Pass	1	0.4%
D/L Fact Flash	1	0.4%
D/L Rwf/Crt/Cspt	7	2.5%
Unable to Start Cert Test		0.0%
Total	9	3.2%

CERTTEST	SBR4025	Total
Total Tested	276	276
Passed	247	247
Failed	29	29
Yield	89.5%	89.5%

Failure Mode	SBR4025	%
Age 04 (Latch Test)		0.0%
Age 07 (AFC Check)		0.0%
Age 08 (PES)	12	4.3%
Age 0B (Resonance)	4	1.4%
Age 20 (Access Times)		0.0%
Age 23 (Stop/Start)	1	0.4%
Age 31		0.0%
Age 30		0.0%
Age 35		0.0%
Age 36		0.0%
Age 38		0.0%
Age 3E	6	2.2%
Age 3F		0.0%
Age 42 (W/R Compare)	3	1.1%
Age 47 (Trk Encroachment)		0.0%
Age 4C (W/R Pack)		0.0%
DFC999	1	0.4%
CFP326	2	0.7%
Testing Age 16 Capacity Tuning		0.0%
Testing Age 42 Trk Encroachment		0.0%
Testing Age 0B		0.0%
Testing Age 3F		0.0%
Testing Age 4C		0.0%
Testing Age 36		0.0%
Testing Age 38		0.0%
Testing Age 42		0.0%
cmt (Cert undetermined Fail)		0.0%
cmt (Read E1 Log)		0.0%
Total	29	10.5%

CMFT(Final)	SBR4025	Total
Total Tested	247	247
Passed	245	245
Failed	2	2
Yield	99.19%	99.2%

Failure Mode	SBR4025	%
FNP326 Rd E1 Log	1	0.4%
FNT123 Set AT Stuff	1	0.4%
		0.0%
		0.0%
Total	2	1%

CUM 85.96%

Table 5.1 Details of testing result of **evaluation group** at drive level.

SUBJECT SBR4064 - Control group HSAs

PRETEST	SBR4064	Total
Total Tested	270	270
Passed	261	261
Failed	9	9
Yield	96.7%	96.7%

Failure Mode	SBR4064	%
RdPCB		0.0%
TI (E1 Log Check)		0.0%
TI (E2 Log Check)		0.0%
2nd Comm Check		0.0%
Proqual		0.0%
Write Pass	1	0.4%
D/L Fact Flash	1	0.4%
D/L Rwf/Crt/Cspt	6	2.2%
Write E1 Log	1	0.4%
Total	9	3.3%

CERTTEST	SBR4064	Total
Total Tested	261	261
Passed	220	220
Failed	41	41
Yield	84.3%	84.3%

Failure Mode	SBR4064	%
Age 04 (Latch Test)		0.0%
Age 07 (AFC Check)	3	1.1%
Age 08 (PES)	29	11.1%
Age 0B (Resonance)		0.0%
Age 20 (Access Times)		0.0%
Age 23 (Stop/Start)	3	1.1%
Age 31	1	0.4%
Age 34	1	0.4%
Age 35		0.0%
Age 36		0.0%
Age 38		0.0%
Age 3E	2	0.8%
Age 3F		0.0%
Age 42 (W/R Compare)		0.0%
Age 47 (Trk Encroachment)		0.0%
Age 4C (W/R Pack)		0.0%
DFC999		0.0%
CFP326	2	0.8%
Testing Age 16 Capacity Tuning		0.0%
Testing Age 42 Trk Encroachment		0.0%
Testing Age 0B		0.0%
Testing Age 3F		0.0%
Testing Age 4C		0.0%
Testing Age 36		0.0%
Testing Age 38		0.0%
Testing Age 42		0.0%
cmt (Cert undetermined Fail)		0.0%
cmt (Read E1 Log)		0.0%
Total	41	15.7%

CMFT(Final)	SBR4064	Total
Total Tested	220	220
Passed	220	220
Failed	0	0
Yield	100.00%	100.0%

Failure Mode	SBR4064	%
		0.0%
		0.0%
		0.0%
		0.0%
Total	0	0%

CUM 81.48%

Table 5.2 Details of testing result of **control group** at drive level.

5.6 Conclusion of Evaluation and Control Plan

5.6.1 Conclusion of Evaluation

Qualification performed on Ultra4.

- No statistical difference at HGA level between Control group and Evaluation group except mean of Gram_In is closer to target 2.5 grams that leads to decrease in gramload adjustment.
- Tail Tack not needed for product performance
- FOS overhang issue was closed after taking corrective actions.
- No statistical difference at drive level between Control group and Evaluation group.
- Process issues are under control and working.
- In summary, Tack tail elimination at HGA level show no effect at all levels.

5.6.2 Benefits

1) Improve capacity

Tack tail operation is proposed to eliminate from HGA assembly line because it is the bottleneck operation of HGA assembly process. The capacity of Ultra4 HGA line is limited at 10,500 units loading per cell per day because of this operation. After tack tail operation was eliminated from Ultra4 HGA process, cell capacity will not be limited with tack tail operation forever.

2) Gramload improvement

T-Test of means shows no significantly different between gramload of evaluation group and target of 2.5 grams. Long run will be performed after elimination tack tail implementation to study the percentage of adjusted units and % times adjusted. This study leads to Autogram stations reduction or sampling autogram.

3) Cost saving

From this implementation on Ultra4 product, Seagate can save its costs in term of Operators, Fixtures, Epoxy (Adhesive) usage, and space that are shown in table 5.3

Tail tacking	100%	Eliminate	Save	Saving Cost
Operator	2	0	2 Optrs/shift/cell	\$35.4/cell/day
Fixture	2	0	2 fixtures/cell	\$114/cell
Epoxy Usage	12.24 Tubes/k	0	LD227 (12.24 tubes/k)	\$27.74/cell/day
Space	120	120	120 cm ² /cell	

*** Tube/k = Number of epoxy in tube used for 1000 units.

Table 5.3 Cost saving from tack tail elimination.

5.6.3 Process Control Plan

1) HGA Operation: Damper Application

- Process change instruction: Add element to insert the FOS tail into the capture of suspension with special tweezers for prevent sticky from damper which may be left on the tweezers to contact with FOS and then will be apply damper and self inspection for FOS tail out of capture during apply damper process.

2) HSAs Operation : FOS Trimming

- Operator instruction: Operator will be aware when cutting down-tab HGAs, the direction of cutting will push FOS away from head and FOS tail may be out of capture.

3) HSA Operation : FOS preparation, Reflow soldering

- The tails of the FOS are free to curl and move side to side once the HGA is installed in the E-block. This increased ability to move does seem to allow more 'tangling' of the FOS tails. The tails can be 'de-tangled' but it takes a little more operator awareness and care
- Operator instruction: Operator self inspection for “FOS tail out of capture” during prepare FOS and soldering process
 - The FOS prepare operator has to use two hands instead of one. One hand is at the FOS to weave the tail through the capture tabs (the tail comes out). The other hand is at the tail to perform the normal operation

4) FOS Overhang the edge of the E-block

- FOS Tail is raised above the arm slot (> 50% of FOS width is raised up from arm slot) when compare to HSA. When combined with improper HSA pick up from HSA tray then the FOS over hang on HD_3 of U4 -4 heads can be occurred. Note that HD_3 is in the last head when the HSA in the tray.