



## CHAPTER III EXPERIMENT

### 3.1 Material

This experiment used glass bead particle (Spacer Application Glass Beads, Potters Industries Inc.) on the thin bed, which the particle-size was approximated 530  $\mu\text{m}$ . The skeleton density of these particles was 2.503  $\text{g}/\text{cm}^3$  and the minimum fluidization of these particles was approximately 23.00  $\text{cm}/\text{sec}$ . The rising velocities of bubbles depended on bubble size.

### 3.2 Equipment

The IIT experimental setup used for the gas-solids flows in two-dimensional fluidized bed was shown schematically in figure 3.1. A rectangular bed was constructed from glass sheets to prevent particles from sticking on the wall of the bed and to facilitate visual observation and video recording of the bed operations such as bubbling, bed expansion, and the mixing and segregation of solids. The bed height was 0.585 m and the cross-section was 0.154 m by 0.022 m. In the order to achieve a uniform fluidization, a rectangular gas distributor consisted of two main regions separated by on perforated plate with 165 x 1400 mesh 304L stainless steel wire (Newark Wire Cloth Company): the distributor and the fluidized bed. The height of distributor was 0.189 m. Air passed through a bed of activated silica gel, introduced from a compressor, was entered the upper segment through a perforated plate. Air flow was measured by means of rotameter of F.&P. CO. The calibration curve of rotameter was obtained from American Orifice Flow Prover used the principles of orifice meters. For another region upper the perforated plate, this region contained 530  $\mu\text{m}$  glass bead particles, selected the sizes by U.S. Standard Sieve: 500  $\mu\text{m}$  and 590  $\mu\text{m}$ . The initial bed height was 14.25 cm.

The particle velocity vector was measured by means of a High Resolution Micro/Measuring System, as described in detail by Gidaspow (1994). It consisted

essentially of two units: a high resolution of micro-image system and a data managing system. The high resolution of micro-image system was a 2/3 inch color video camera which used a Charge Couple Device (CCD), a solid stage image sensor. This CCD camera was a Sony DXC-151A with Navitron TV zoom lens 18-108mm and closed up focus transferred its field of view into the monitor. And it had ten electronic shutter settings and four modes for gain control. The horizontal resolution of the camera was 460 TV line, and a sensitivity of 2000 lux at 0 dB for gain. A light source was fiber optical light, used for good visualization of microscopic movement of particles. The camera adapter was a Sony CMA-D2, which connected the camera to a personal computer Intel Inside Pentium 300 MHz. The personal computer had a Micro-Imaging Board and Micro-Imaging Software, Pro Image-Plus for data measurement and analysis.

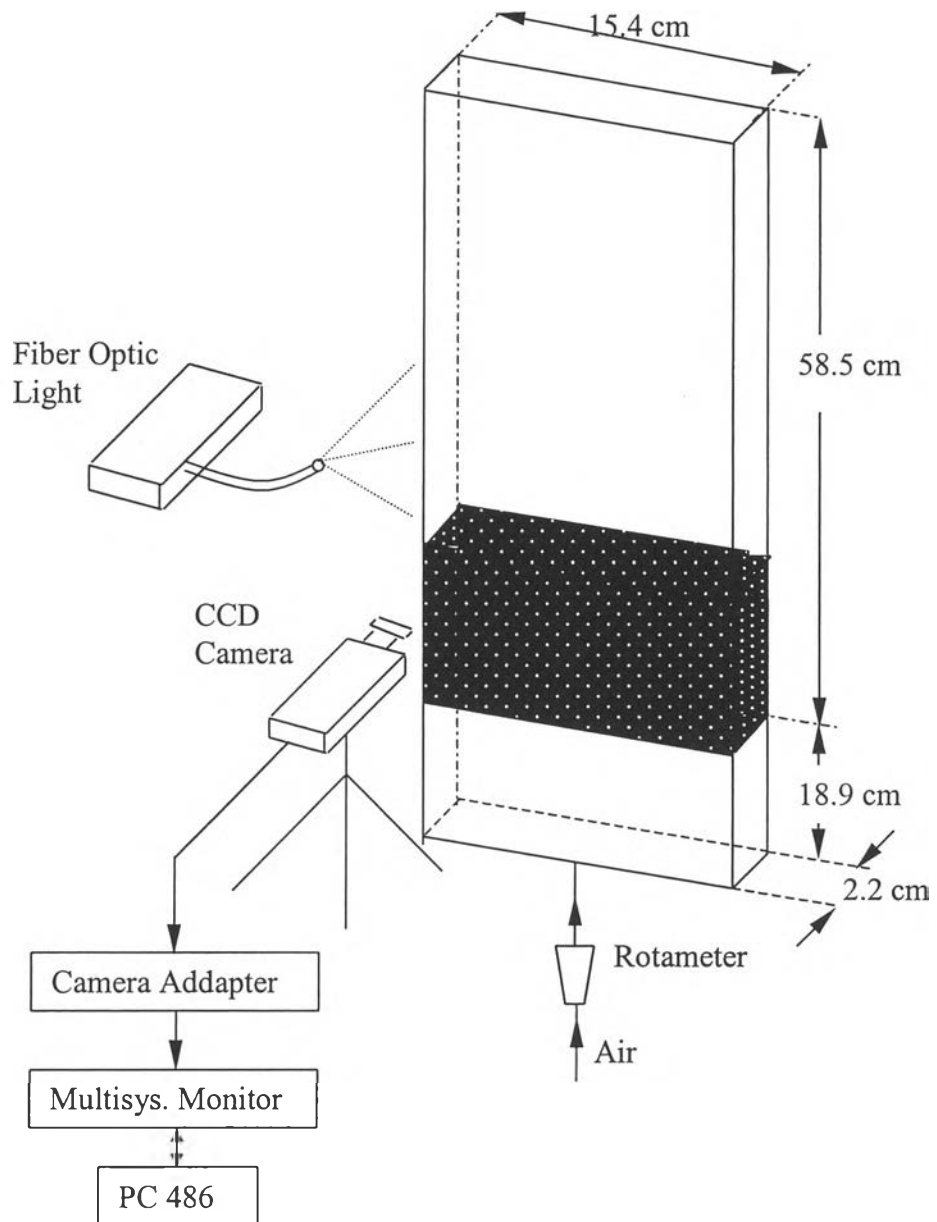

**Figure 3.1** A schematic diagram of the experimental apparatus of the gas–solid in two dimensional fluidized beds.

### 3.3 Methodology

The movement of the bubbles in the fluidized bed was recorded by the video camera. CCD camera was used to find mean particle size, velocity of each particle inside the bubble, solid volume fraction, shear stress, and Reynolds stress. But bubble's velocity and bubble size received from a digital video camcorder (Canon). An interval time of each picture was approximately 0.45 second. The snapped pictures were analyzed by Pro Image-Plus program. This program could draw the stripped line and kept the length, angle, and position of this strip line. It can transfer these data to Microsoft Excel.

The calibration curve of rotameter was obtained from American Orifice Flow Prover used the principles of orifice meters shown in figure 3.2. Air flow rate was calculated from Eq.(3.1) as follows (McCabe and Smith, 1985):

$$Q_o = \frac{C_o A}{\sqrt{1 - \beta^4}} \sqrt{\frac{2\Delta P}{\rho}} \quad (3.1)$$

where  $C_o$  is the orifice coefficient,  $\beta$  is the ratio of orifice diameter to pipe diameter,  $\Delta P$  is the pressure difference between orifice and Prover exit,  $\rho$  is the density of air, and  $A$  is the cross-section area of the orifice.

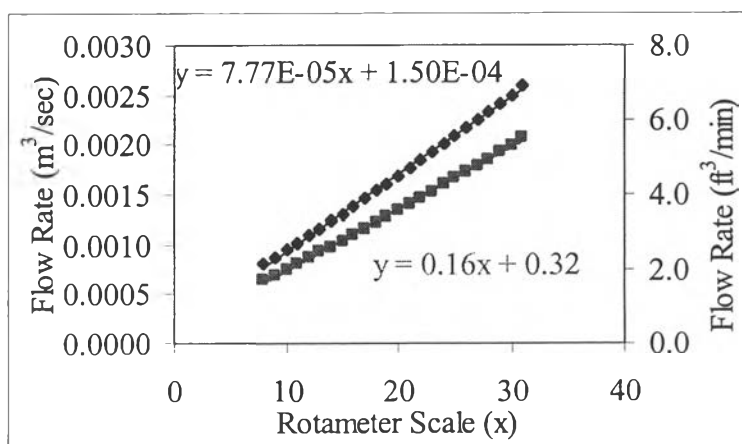

**Figure 3.2** Calibration curve of rotameter obtained from american orifice flow prover.

The material used as the solids was glass sphere with density of  $2500 \text{ kg/m}^3$  and average particle diameter of  $530 \text{ }\mu\text{m}$  obtained from captured pictures with CCD Camera as shown in figure 3.3. The minimum fluidization velocity was estimated by means of a pressure drop measurement by varying superficial air velocity (Gidaspow, 1994). It was  $22.9 \text{ cm/sec}$  for a  $530 \text{ }\mu\text{m}$  glass beads. The solids was charged into the fluidized bed to give a static bed height of  $0.14 \text{ m}$  for experiment and then fluidized with a uniform inlet gas velocity.

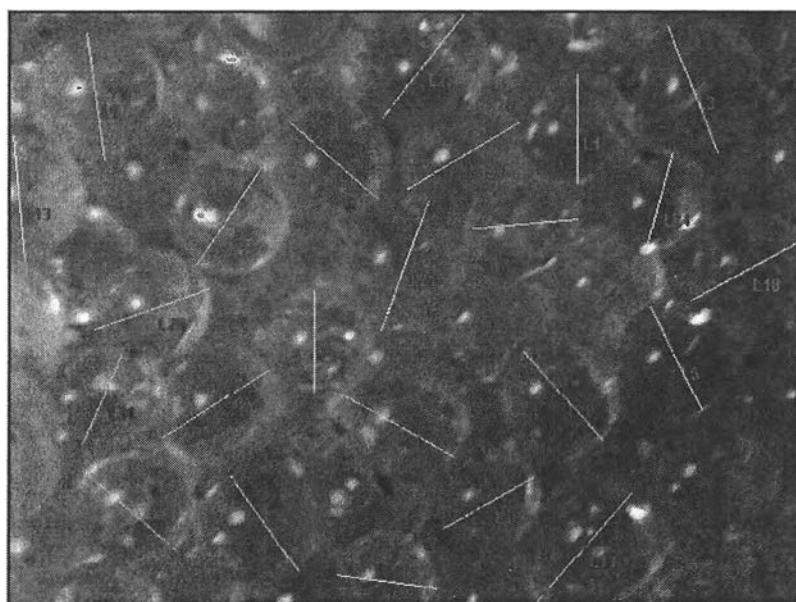

**Figure 3.3** The photo of  $530 \text{ }\mu\text{m}$  glass beads captured by CCD camera.

### 3.3.1 The Instantaneous Particle Velocity in the Bubble

The instantaneous particle velocity in the bubble could be found from the Particle Image Velocimetry (PIV) method by using CCD camera technique and Pro Image Plus program. This technique was used to measure the axial, and radial velocities of the particles, described by Gidaspow, et al. (1996). The uniform inlet gas velocity in a two-dimensional IIT gas-solids fluidized bed was  $33.55 \text{ cm/sec}$  by pressure  $30 \text{ psig}$  at the compressor. The initial height of packed bed was  $14.25 \text{ cm}$

and CCD camera kept the data at height 14 cm for 5 positions: two left, center, and two right.

Figure 3.4 showed a typical streak made by the glass bead particles of  $530\ \mu\text{m}$  at a shuttle speed of  $1/1000\ \text{sec}$ . These streak lines represented the distance traveled by the particles in a given time interval specified on the camera. The images were captured and digitized by the Image-Pro Plus software. To obtain reliable velocity information, time between exposures had to be selected so as to obtain a sufficient displacement to achieve an acceptable velocity resolution, but it had not to be so large that the particle moved out of the field of view.

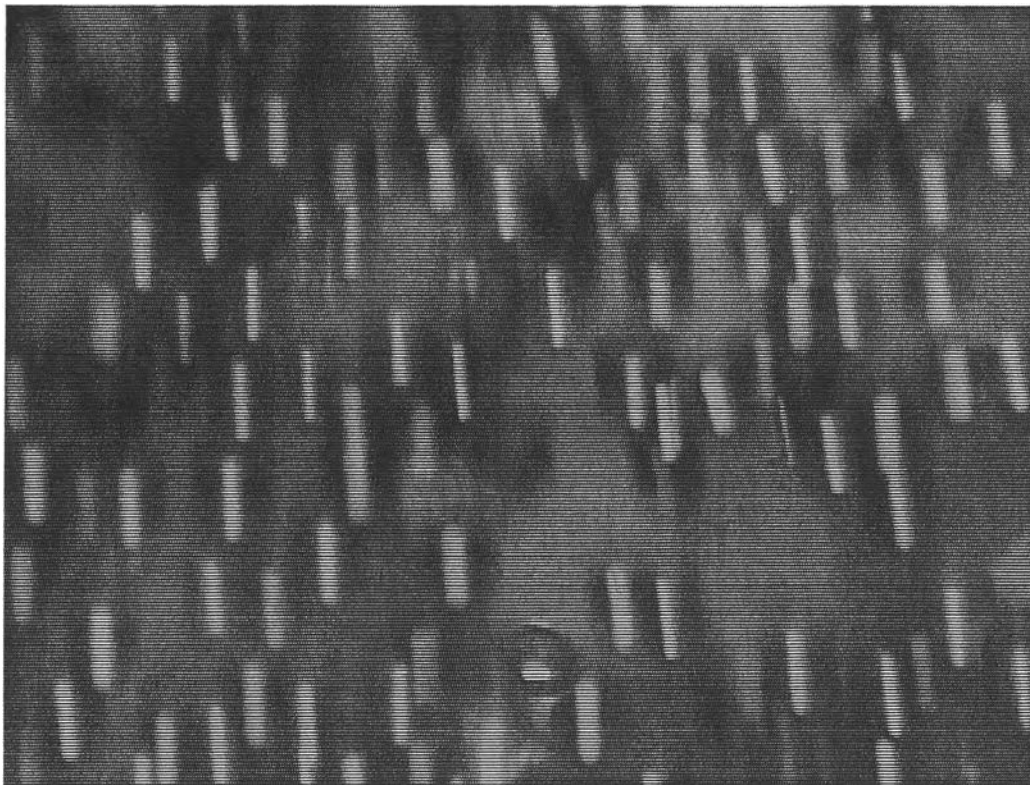

**Figure 3.4** Typical streak line of  $530\ \mu\text{m}$  glass beads made by CCD camera with a shuttle speed of  $1/1000\ \text{sec}$ .

The local velocity was then estimated by dividing the distance of the streak line by time of shutter speed. The radial and the axial velocity components were determined from Eq.(3.2), and Eq.(3.3), respectively

$$v_x = \frac{\Delta L}{t} \sin \alpha \quad (3.2)$$

$$v_y = \frac{\Delta L}{t} \cos \alpha \quad (3.3)$$

where,  $\Delta L$  is the distance traveled,  $\alpha$  is the angle from horizontal,  $1/t$  is the inverse of shutter speed, and  $v_x$  and  $v_y$  are the axial and radial velocity components, respectively.

The light after touching glass bead composed of the reflected light and the refracted light as shown in figure 3.5. If light source was placed in the front of the bed, the reflected light from glass bead to CCD camera was not sufficiently to obtain the good streak lines on the snapped picture. The refracted light was not go back through CCD camera directly. Therefore, the light source was moved to the back of the bed. This way the CCD camera could receive the refracted light of glass bead.

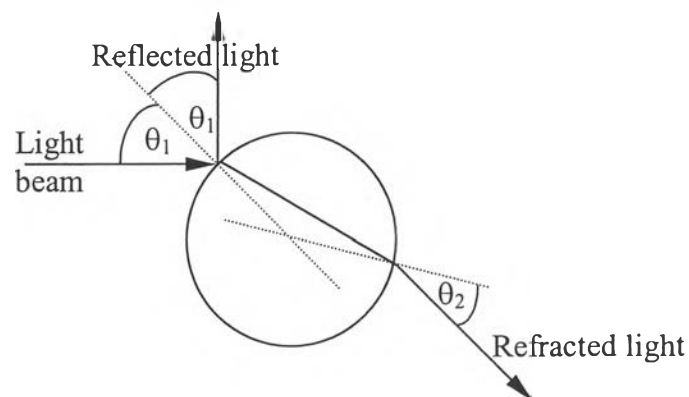

**Figure 3.5** The diagram shows the reflected light and refracted light.

The particle velocities in the bubble were easy to obtain from thin bed (2.2 cm) when the light source stayed behind the bed as shown in figure 3.6. For thick bed (9.3 cm), the bubble would not cover over all the thickness of the bed. The light could not pass through the bed. Therefore, my experiment used the thin bed.

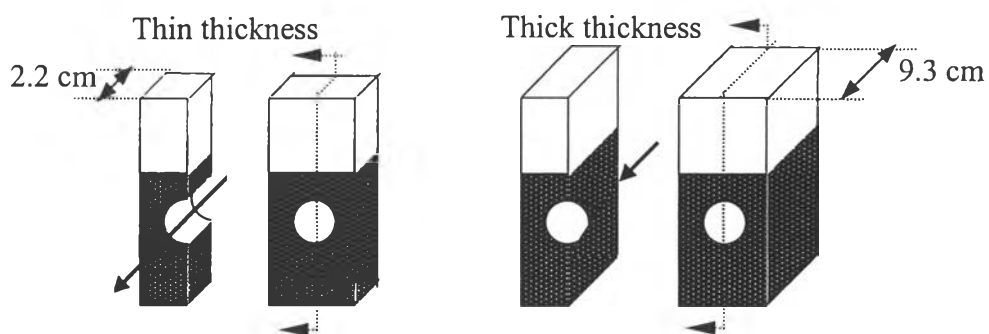

**Figure 3.6** Cross section diagrams of thin and thick bed show the bubble.

### 3.3.2 Bubble Velocity and Bubble Size

Bubble was recorded by a digital video camcorder (Canon) and then captured and analyzed using Image-Pro Plus software. The bubble velocity was found from merging every snapped picture. It showed the movie on frame by frame. The distance of bubble was measured by Pro Image Plus. Bubble velocity equaled to the distance of bubble moving divided by time. Bubble diameter was measured from the bed height of between 10 cm and 20 cm. Figure 3.7 showed the experimental bubble size captured by a video camcorder. The line in Figure 3.7 represented bubble diameter.

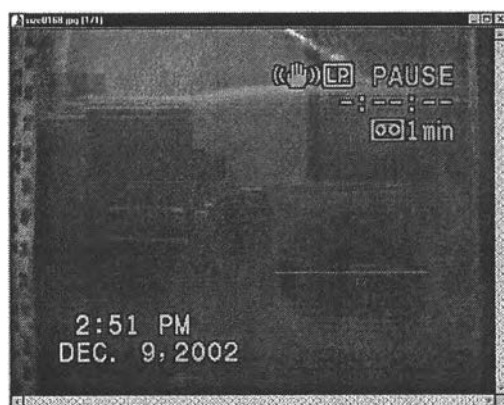

**Figure 3.7** Video camcorder captured photo of the bubble for bubble diameter measurement.



### 3.3.3 Reynolds Stress and Shear Stress

The velocity fluctuation in the bubble was assumed to be statistical average. Therefore, when these velocities were plotted to show in histogram graph, they should be similar to the Maxwell-Boltzmann velocity distribution. The Reynolds stresses in x- and y-direction could be calculated by using Eq.(3.6) and Eq.(3.9), respectively. These two equations were derived from Eq.(3.4) and Eq.(3.5), and Eq.(3.7) and Eq.(3.8), respectively.

$$u_j = \frac{1}{n_j} \sum_{i=1}^{n_j} c_{x_{i,j}} \quad (3.4)$$

$$\langle C_x C_x \rangle_j = \frac{1}{n_j} \sum_{i=1}^{n_j} (c_{x_{i,j}} - u_j)^2 \quad (3.5)$$

$$\langle \overline{C_x C_x} \rangle = \frac{1}{N} \sum_{j=1}^N \langle C_x C_x \rangle_j \quad (3.6)$$

where  $c_{x_{i,j}}$  is the radial velocity of the  $i^{\text{th}}$  particle on the  $j^{\text{th}}$  frame.  $u_j$  is the average radial velocity of the particle on the  $j^{\text{th}}$  frame.  $\langle C_x C_x \rangle_j$  is the Reynolds stress in x-direction on the  $j^{\text{th}}$  frame. Each frame is different the time; therefore,  $\langle C_x C_x \rangle_j$  changes with the time. And  $\langle \overline{C_x C_x} \rangle$  is the average Reynolds stress in x-direction by the sum of every Reynolds stress in x-direction divided by the total number of the their data.

$$v_j = \frac{1}{n_j} \sum_{i=1}^{n_j} C_{y_{i,j}} \quad (3.7)$$

$$\langle C_y C_y \rangle_j = \frac{1}{n_j} \sum_{i=1}^{n_j} (C_{y_{i,j}} - v_j)^2 \quad (3.8)$$

$$\langle \overline{C_y C_y} \rangle = \frac{1}{N} \sum_{j=1}^N \langle C_y C_y \rangle_j \quad (3.9)$$

where  $c_{y,i,j}$  is the axial velocity of the  $i^{\text{th}}$  particle on the  $j^{\text{th}}$  frame.  $v_j$  is the average axial velocity of the particle on the  $j^{\text{th}}$  frame.  $\langle C_y C_y \rangle_j$  is the Reynolds stress in y-direction on the  $j^{\text{th}}$  frame. Each frame is different the time; therefore,  $\langle C_y C_y \rangle_j$  changes with the time. And  $\langle \overline{C_y C_y} \rangle$  is the average Reynolds stress in y-direction by the sum of every Reynolds stress in y-direction divided by the total number of the their data.