

DATA ANALYSIS OF VOLATILE COMPOUNDS IN GREEN CURRY PASTE BY  
COMPREHENSIVE HEARTCUT TWO-DIMENSIONAL GAS CHROMATOGRAPHY-MASS  
SPECTROMETRY USING RETENTION INDICES FOR NONPOLAR AND POLAR COLUMNS



A Thesis Submitted in Partial Fulfillment of the Requirements  
for the Degree of Master of Science in Chemistry

Department of Chemistry

FACULTY OF SCIENCE

Chulalongkorn University

Academic Year 2022

Copyright of Chulalongkorn University

การวิเคราะห์ข้อมูลของสารระเหยง่ายในพริกแกงเขียวหวานโดยแก๊สโครมาโทกราฟี-แมสสเปกโตรเม  
ตรีสองมิติแบบฮาร์ทคัทอย่างทั่วถึงโดยใช้รีเทนชันอินเด็กซ์สำหรับคอลัมน์ไม่มีขั้วและมีขั้ว



วิทยานิพนธ์นี้เป็นส่วนหนึ่งของการศึกษาตามหลักสูตรปริญญาวิทยาศาสตรมหาบัณฑิต  
สาขาวิชาเคมี ภาควิชาเคมี  
คณะวิทยาศาสตร์ จุฬาลงกรณ์มหาวิทยาลัย  
ปีการศึกษา 2565  
ลิขสิทธิ์ของจุฬาลงกรณ์มหาวิทยาลัย

Thesis Title DATA ANALYSIS OF VOLATILE COMPOUNDS IN GREEN CURRY PASTE BY COMPREHENSIVE HEARTCUT TWO-DIMENSIONAL GAS CHROMATOGRAPHY-MASS SPECTROMETRY USING RETENTION INDICES FOR NONPOLAR AND POLAR COLUMNS

By Miss Sudarat Arunmongkon

Field of Study Chemistry

Thesis Advisor Associate Professor THUMNOON NHUJAK, Ph.D.

Thesis Co Advisor Assistant Professor CHADIN KULSING, Ph.D.

---

Accepted by the FACULTY OF SCIENCE, Chulalongkorn University in Partial Fulfillment of the Requirement for the Master of Science

..... Dean of the FACULTY OF SCIENCE  
(Professor POLKIT SANGVANICH, Ph.D.)

THESIS COMMITTEE

..... Chairman  
(Professor VUDHICHAJ PARASUK, Ph.D.)

..... Thesis Advisor  
(Associate Professor THUMNOON NHUJAK, Ph.D.)

..... Thesis Co-Advisor  
(Assistant Professor CHADIN KULSING, Ph.D.)

..... Examiner  
(Assistant Professor PUTTARUKSA VARANUSUPAKUL,  
Ph.D.)

..... External Examiner  
(Assistant Professor Natthida Sriboonvorakul, Ph.D.)

สุดารัตน์ อรุณมงคล : การวิเคราะห์ข้อมูลของสารระเหยง่ายในพริกแกงเขียวหวานโดยแก๊สโครมาโทกราฟี-แมสสเปกโตรเมตรีสองมิติแบบฮาร์ทคัทอย่างทั่วถึงโดยใช้รีเทนชันอินเด็กซ์สำหรับคอลัมน์ไม่มีขั้วและมีขั้ว. ( DATA ANALYSIS OF VOLATILE COMPOUNDS IN GREEN CURRY PASTE BY COMPREHENSIVE HEARTCUT TWO-DIMENSIONAL GAS CHROMATOGRAPHY-MASS SPECTROMETRY USING RETENTION INDICES FOR NONPOLAR AND POLAR COLUMNS) อ.ที่ปรึกษาหลัก : รศ. ดร.ธรรมบุญ หนูจักร, อ.ที่ปรึกษาร่วม : ผศ. ดร.ชฎิล กุลสิงห์

ในงานวิจัยนี้ได้ประยุกต์แก๊สโครมาโทกราฟีสองมิติแบบฮาร์ทคัท-แมสสเปกโตรเมตรีชนิดครอบคลุมคู่กับแมสสเปกโตรเมตรี (CH/C MDGCMS) สำหรับการพิสูจน์ทราบสารประกอบระเหยง่ายในตัวอย่างพริกแกงเขียวหวาน โดยใช้คอลัมน์ที่หนึ่งชนิดไม่มีขั้วเป็น HP-5MS (ยาว 30 m x เส้นผ่าศูนย์กลาง 250  $\mu\text{m}$  x ความหนาของเฟสคงที่ 0.25  $\mu\text{m}$ ) ต่อเข้ากับเฟลมไอออนเซชันดีเทคเตอร์ และคอลัมน์ที่สองชนิดมีขั้วเป็น DB-WAX (ยาว 60 m x เส้นผ่าศูนย์กลาง 250  $\mu\text{m}$  x ความหนาของเฟสคงที่ 0.5  $\mu\text{m}$ ) ต่อเข้ากับแมสสเปกโตรมิเตอร์ ในการวิเคราะห์ด้วย CH/C MDGC ได้ฉีดตัวอย่างทั้งหมด 25 ครั้ง รวมเวลาวิเคราะห์ทั้งสิ้น 20.83 ชั่วโมง โดยแต่ละครั้งใช้ดีนสวิตซ์สำหรับพาสารตัวอย่างออกจากคอลัมน์ที่หนึ่งไปยังคอลัมน์ที่สองด้วยการสลับดีนสวิตซ์แบบฮาร์ทคัท 8 รอบ โดยแต่ละรอบฮาร์ทคัทวินโดว์ที่ 0.2 นาที และการแยกในคอลัมน์ที่สองภายใน 5 นาที

จากการเทียบแมสสเปกตรัมกับฐานข้อมูล NIST17 ด้วยคะแนนความเหมือนที่มากกว่า 650 และค่ารีเทนชันอินเด็กซ์ของคอลัมน์ที่หนึ่งและคอลัมน์ที่สอง สามารถพิสูจน์ทราบสารประกอบระเหยง่ายของพริกแกงเขียวหวานได้ทั้งหมด 42 ชนิด โดยที่พบมากเป็น 10 อันดับแรกได้แก่ tumerone (14.90%),  $\beta$ -cubebene (8.77%),  $\alpha$ -ocimene (8.05%), terpinen-4-ol (5.30%), sabinene (3.21%), terpinolene (3.09%), ledol (3.07%), a-pinene (1.66%), g-terpinene (1.59%) และ b-phellandrene (1.51%) นอกจากนี้ ค่า peak capacity เป็น 5,840 ทำให้สามารถพิสูจน์ทราบพิศสารได้ทั้งหมด 245 พิศ

จุฬาลงกรณ์มหาวิทยาลัย  
CHULALONGKORN UNIVERSITY

สาขาวิชา เคมี  
ปีการศึกษา 2565

ลายมือชื่อนิสิต .....  
ลายมือชื่อ อ.ที่ปรึกษาหลัก .....  
ลายมือชื่อ อ.ที่ปรึกษาร่วม .....

# # 6172145023 : MAJOR CHEMISTRY

KEYWORD:

Sudarat Arunmongkon : DATA ANALYSIS OF VOLATILE COMPOUNDS IN GREEN CURRY PASTE BY COMPREHENSIVE HEARTCUT TWO-DIMENSIONAL GAS CHROMATOGRAPHY-MASS SPECTROMETRY USING RETENTION INDICES FOR NONPOLAR AND POLAR COLUMNS. Advisor: Assoc. Prof. THUMNOON NHUJAK, Ph.D. Co-advisor: Asst. Prof. CHADIN KULSING, Ph.D.

In this work, comprehensive heart cut two-dimensional chromatography hyphenated with mass spectrometry (CH/C MDGCMS) was applied for reliable identification of volatile compounds in green curry paste sample using HP-5MS (30 m length x 250  $\mu\text{m}$  i.d. x 0.25  $\mu\text{m}$  thickness) and DB-WAX (60 m length x 250  $\mu\text{m}$  i.d. x 0.5  $\mu\text{m}$  thickness) for a first non-polar column ( $^1\text{D}$ ) to a flame ionization detector and a second polar column ( $^2\text{D}$ ) to a mass spectrometer, respectively. The CH/C MDGC with 25 injection runs for total analysis time of 20.83 hr was achieved using a Deans switch for transferring eluent from the first to second columns with cyclic 8 H/C events with 0.2 min H/C window and 5 min  $^2\text{D}$  separation for each event.

Using mass spectrum comparison with NIST17 library MS matching score of >650 and retention indices for  $^1\text{D}$  and  $^2\text{D}$ , 42 volatile compounds were identified with ten dominant compounds of tumerone (14.90%),  $\beta$ -cubebene (8.77%),  $\alpha$ -ocimene (8.05%), terpinen-4-ol (5.30%), sabinene (3.21%), terpinolene (3.09%), ledol (3.07%), a-pinene (1.66%), g-terpinene (1.59%) and b-phellandrene (1.51%), respectively. In addition, total peak capacity of 5,840 was obtained with corresponding to 245 identified compound peaks in this work.

Field of Study: Chemistry

Academic Year: 2022

Student's Signature .....

Advisor's Signature .....

Co-advisor's Signature .....

## ACKNOWLEDGEMENTS

This thesis could not be impossible without from many people. I am honored and grateful to thank those who support of my thesis.

First, I would like to grateful thank to my thesis advisor, Associate Professor Dr. Thumnoon Nhujak, for his helpful, supported, guidance. My warmest thank to co-advisor Assistant Professor Dr. Chadin Kulsing for his guidance, helpful advice, and kind encouragement in through all stage of all my thesis. Without these advisor and co-advisor, the thesis would not have been fully completed.

In addition, I would like to thank of all committee for their gentle suggestion and utility comments for my work.

I would like to thank all member of ChromatoKitTaNie lab for their encouragement in through our part in my thesis and give new knowledge for suggestion on this work.

Furthermore, I would like to thank Department of chemistry, Chulalongkorn university for supplying the instruments and all facilities in this research.

Finally, I am special thanks my friend, our beloved family for their helpfulness, supporting, encouragement and behind the success of my education and thesis.

จุฬาลงกรณ์มหาวิทยาลัย  
CHULALONGKORN UNIVERSITY

Sudarat Arunmongkon

## TABLE OF CONTENTS

	Page
.....	iii
ABSTRACT (THAI).....	iii
.....	iv
ABSTRACT (ENGLISH).....	iv
ACKNOWLEDGEMENTS.....	v
TABLE OF CONTENTS.....	vi
LIST OF TABLES.....	viii
LIST OF FIGURES.....	ix
CHAPTER I INTRODUCTION.....	1
1.1 Problem definition.....	1
1.2 Literature review.....	2
1.3 Aim, Scope and expected benefits of this work.....	3
CHAPTER II THEORY.....	5
2.1 Gas chromatography (GC).....	5
2.2 Flame ionization Detector (FID).....	6
2.3 Gas chromatography—mass spectrometry (GC—MS).....	6
2.4 Multidimensional gas chromatography (MDGC).....	7
2.5 Retention index.....	9
2.6 Isovotility curves.....	10
2.7 Untargeted compound identification with 2DGC.....	11
CHAPTER III EXPERIMENTAL.....	13

3.1 Chemical and Sample preparation.....	13
3.2 Instrumentation and apparatus.....	13
3.3 Data analysis.....	18
3.3.1 Identification of volatile compounds .....	18
3.3.2 Calculation of $^1t_R$ , $^2t_R$ and $^1I$ .....	18
3.3.3 Building of isovolatility curves using multi location peak parking .....	19
3.3.4 Improved sample identification using isovolatility curve and $^2I$ calculation. .....	22
CHAPTER IV RESULT AND DISCUSSION .....	24
4.1 CH/C-MDGC-MS analysis of green curry paste extract.....	24
4.2 Tentative identification of compounds in green curry paste extract.....	36
CHAPTER V CONCLUSION .....	38
APPENDICES.....	39
REFERENCES .....	58
VITA.....	63



## LIST OF TABLES

	Page
Table 1 The multiple H/C events cycle consisting of 25 runs. ....	15
Table 2 The set of multi-location peak parking for building isovolatility curves .....	19
Table 3 Volatile compound profiles with literature/experimental retention indices and MS match scores of the green curry paste sample analyzed by CH/C 2DGC-MS. 27	
Table 4 Volatile compound profiles with literature/experimental retention indices of $^1I$ , $^2I$ and MS match scores of the green curry paste sample analyzed by CH/C 2DGC-MS. ....	34



## LIST OF FIGURES

	Page
Figure 1 the diagram of gas chromatograph. Reproduce form [17].....	5
Figure 2 Diagram shown of mass spectrometry. Reproduced from [17].....	7
Figure 3 Diagram of GC—MS. Reproduced from [18].....	7
Figure 4 Schematic diagram of GCxGC technique.....	8
Figure 5 The schematic diagram of CH/C 2DGC technique. ....	9
Figure 6 Flowchart and diagram showing the process of compound confirmation in GCXGC-accurate mass time of flight MS, progressively applying MS library matches and retention index filters to refine the data [31]. A) Contour plot, B) Six isomers, C) Two isomers and D) Compound identified .....	12
Figure 7 The process of multiple peak parking with 1 <sup>st</sup> , 2 <sup>nd</sup> , 3 <sup>rd</sup> and 4 <sup>th</sup> sequences of n-alkane to establish isovolatility curves [27]. ....	22
Figure 8 CH/C 2DGC chromatograms of the green curry paste sample from 1 <sup>st</sup> , 2 <sup>nd</sup> and 3 <sup>rd</sup> injections for 1D separation-FID of A, B and C resulting in 1D + 2D separation-MS showing D, E and F, respectively.....	26

## CHAPTER I

### INTRODUCTION

#### 1.1 Problem definition

Green curry is one the most famous Thai food containing green chilies paste, coconut milk and meat. The green curry paste is typically made from green chilies which contribute to the characteristic pastel green color, and other ingredients such as kaffir lime leaves, curcumin, lemongrass, shrimp paste, garlics, shallots and galangal. This paste is considerably complex sample since it is composed of several hundred volatile compounds such as terpenes, aldehydes, ketones and esters [5].

Gas chromatography (GC) is a general separation technique to analyze volatile compounds. GC is performed using a gas flow through a column and separation of volatile compounds are based on their volatility and interaction with the GC column stationary phase. Gas chromatography-mass spectrometry (GC-MS) is commonly used for identification of compounds by comparing the data from experimental  $m/z$  and retention index values ( $I$ ) with those from National Institute of Standards and Technology (NIST) library. Apart from the used for GC separation and analysis of volatile compounds is one-dimensional gas chromatography (1DGC). However, 1DGC does not always provide sufficient efficiency and selectivity to analyze complex samples such as green curry paste in this work.

The multidimensional gas chromatography (MDGC) is a high-performance separation technique providing high peak capacity for analysis of complex samples. MDGC such as 2DGC is employed using two different selectivity columns connected via a heart-cut (H/C) or a modulation device throughout the one-dimensional ( $^1D$ ) separation on a first column prior to two-dimensional ( $^2D$ ) separation on a second column[7]. This comprehensive heart-cut two-dimensional gas chromatography (CH/C MDGC) can be applied to improve high resolution and peak capacity based on use of a long  $^2D$  column and longer analysis time[8]. CH/C MDGC-MS further allows identification of several hundred volatiles [9-13] by comparing the data from 3 of

criteria with MS match score, retention indices of first column ( $^1I$ ) and second column ( $^2I$ ).

In this study, CH/C MDGCMS technique was applied for determination of volatile compounds in green curry paste sample and data analysis method for improved sample identification was applied according to curve fitting between retention time of second column ( $^2t_R$ ) from the experiments and theoretical calculation. Peak identification approach employing MS match,  $^1I$  and  $^2I$  calculation approach according to isovolatility curve construction. The results were discussed based on the number of correctly identified compounds by comparison with MS match,  $^1I$  and  $^2I$  calculation. The profile of volatile compounds in the green curry paste sample was also reported.

## 1.2 Literature review

As previously mentioned, green curry paste contains various ingredients such as green curry paste: green chilies, garlics, shallots, lemongrass, galangal and kaffir leaves. Most of previous work on determination of volatile compounds involved GC.

Using two-dimensional gas chromatography—mass spectrometry (2DGC—MS) for analysis of solid phase microextraction (SPME) of green chilies (capsicum) cultivated in Malaysia [4], 184 volatile compounds divided into 9 functional groups were reported: 26 alkanes, 20 alcohols, 17 aldehydes, 8 ketones, 68 esters, 3 ethers, 40 terpenes, 1 pyrazine and 1 sulfide. nine main compounds included  $\alpha$ -pinene,  $\alpha$ -tricyclene, (*R*)- $\alpha$ -pinene, camphene, sabinene,  $\beta$ -myrcene,  $\beta$ -pinene,  $\alpha$ -phellanderene and *o*-cymene.

In GC—MS analysis with headspace extraction of fresh garlic [3], the following major volatile compounds were found: diallyl trisulfide (21.3%), diallyl disulfide (21.0%), 2-butenal (12.0%) and allyl methyl sulfide (3.6%). However, the following major volatile compounds were found in black garlic: allyl methyl sulfide (18.2%), furfural (17.3%) and 2-methylene-4-pentenal (14.9%).

For GC—MS analysis of solvent extract of shallots [14], fresh and baked shallots were found to contain thiols, unsaturated-monosulfide, saturated-disulfides,

unsaturated-trisulfides, thiophenes and oxygen compounds, while the fried shallot was found to contain 93 volatile compounds, along with major sulfur-containing compounds including hexanal, (*E*)-2-heptenal, (*E*)-2-octenal, dipropyl di-sulfide, 2-ethyl-3,5-dimethylpyrazine, and 1-octen-3-ol.

In GC–MS analysis of essential oils of lemongrass from Madinah capital in Egypt and Saudi Arabia, the major volatile compounds were obtained: geranial (20.9%), neral (16.2%), geraniol (8.3%) and linalool (5.6%).

Using hydrodistillation of galangal by GC–MS [15], the following characteristic volatile compounds were detected: 8-cineole, trans-2,3-acetoxy-1,8-cineoles. In addition, using the steam distillation reduce pressure for extraction of galangal prior to GC–MS analysis, the following stereo isomers were identified: 8-cineole (trans), 8-cineole (cis), -acetoxy-1,8-cineole (trans), 3-acetoxy-1,8-cineole (cis).

In analysis of kaffir leaves using GC–MS with supercritical CO<sub>2</sub> extraction (SFE) [6], results revealed 21 terpenoids classified to be 3 monoterpenes, 5 oxygenated monoterpenes, 9 sesquiterpenes and 4 oxygenated terpenoids.

In addition, using GC–MS with SPME [16], 54 volatile compounds in fresh and dried kaffir leaves were identified with citronellal as the most abundant, along with the following volatile compounds: *L*-linalool, hexanal, sabinene and  $\beta$ -citronellol. Furthermore, citronellal and *L*-linalool were key aroma compounds in fresh and dried kaffir leaves.

### 1.3 Aim, Scope and expected benefits of this work

The aim of this work is to improve identification of volatile compounds in green curry paste using a CH/C MDGCMS approach. The peak capacity in <sup>2</sup>D separation will be also investigated and the data analysis result will be performed according to approach. CH/C MDGCMS will be performed using HP-5MS (30 m length x 250  $\mu$ m i.d. x 0.25  $\mu$ m thickness) and DB-WAX (60 m length x 250  $\mu$ m i.d. x 0.5  $\mu$ m thickness) for first non-polar and second polar columns, respectively. These two columns are connected by deans switch for 8 H/C events. Each event is performed

with an on-mode to transfer the eluent from the first column to FID, and H/C is an off-mode to transfer the eluent from the second columns to MS.

Green curry paste will be extracted with hexane and then 25 injection runs of green curry paste extract are analyzed by CH/C MDGCMS with deferent duration of off-/on-mode for Deans switch with an H/C time by switching every 0.2 min for the off-mode and every 5 min for the on-mode. The data analysis result for identification of each volatile compounds is performed according to MS matching  $>650$ ,  $^1/$  and  $^2/$  library matches

The benefit of this work is to gain analytical approach of CH/C MDGCMS for identification of volatile compounds in green curry paste using confident confirmation of MS matching  $>650$  and both  $^1/$  on non-polar column and  $^2/$  on polar column.



## CHAPTER II

### THEORY

#### 2.1 Gas chromatography (GC)

Gas chromatography is an analytical technique for the separation of a volatile compounds. As shown in Figure 1, GC instrument consist of 3 parts including: an injection port, an oven and a detector. A sample introduction to the injection port may be performed using a manual syringe, an autosampler or SPME either manual or automated. The sample is then volatile and transferred by carrier gas with a spitless or split mode for low or high concentration of analytes, respectively, to a column in the oven. The analytes were separated depending on their different interactions with stationary phase in the column. For example, (5%-Phenyl)-methylpolysiloxane (HP-5) stationary phase is classified to be a non-polar column that is suitable for separating non-polar analytes. The separation efficiency also depends on experimental conditions, temperature program, column length, flow rate, and column dimension. The GC detectors used include FID and MS.

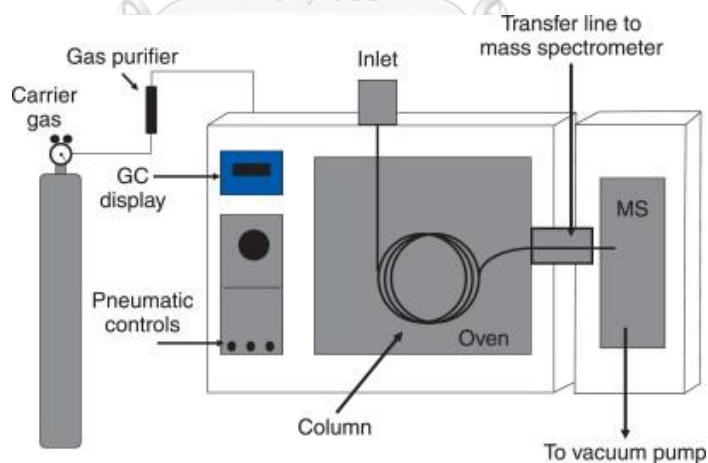

**Figure 1** the diagram of gas chromatograph. Reproduce form [17]

## 2.2 Flame ionization Detector (FID)

The flame ionization detector (FID) is a detector widely used for GC detection of organic compounds due to wide dynamic range, low detection (LOD), reliability, high acquisition frequency and limited internal volume. The FID was commonly used couple GC—FID and 2DGC—FID where analytes in gas phase eluent are burnt in a flame to produce analytes ions detected by an electrode. The GC—FID chromatogram is a complexly highlighting of analysis for a multidimensional GC method.

## 2.3 Gas chromatography—mass spectrometry (GC—MS)

MS is a widely analytical detection technique used to identify unknown compounds in a sample. As shown in Figure 2, the MS detection is based on ionization and fragmentation of analyte in a gas phase to obtain a unique pattern of analyte fragments with various values of mass-to-charge ratio ( $m/z$ ) at particular intensity of relative abundance. A mass spectrum is a histogram of the ion relative abundance versus the  $m/z$  values and represents a fingerprint of a particular analyte with structural information. Therefore, GC-MS analysis can provide information of the analyte with its retention time and mass spectrum, where the retention time can be used to evaluate retention index using long chain hydrocarbon standards, and the mass spectrum of the analyte can be compared with mass spectra of NIST library reference standards. GC-MS analysis can improve analyte identification.

As a shown in Figure 3, after the analyte is eluted from the GC column outlet, it is transferred to the MS interface and then ionized in the ion source. The outcome of fragment ions is through a mass analyzer for separation of the fragment ions according to their  $m/z$  values and then detected by the ion detector.



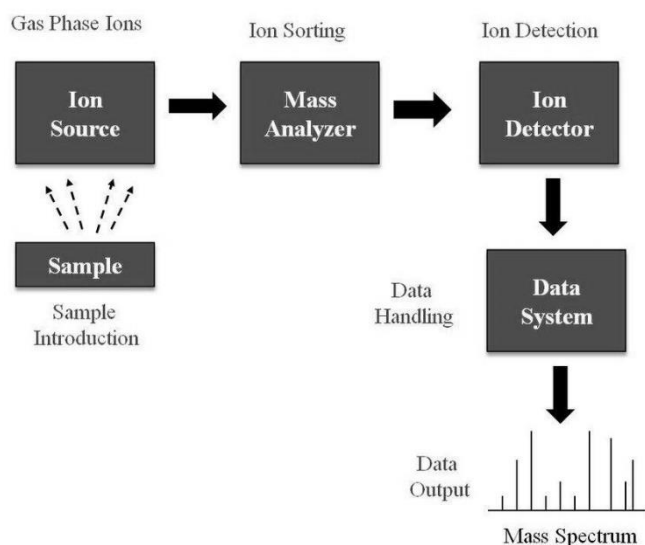

Figure 2 Diagram shown of mass spectrometry. Reproduced from [17]

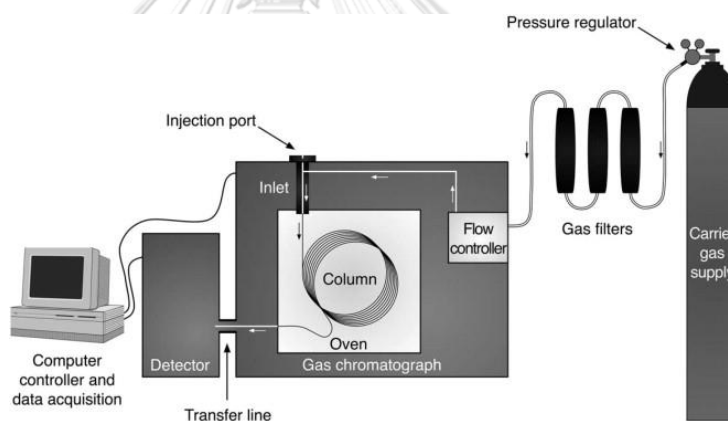

Figure 3 Diagram of GC—MS. Reproduced from [18]

## 2.4 Multidimensional gas chromatography (MDGC)

MDGC is applied for analysis of multi-component samples. This technique consists of two columns with different selectivity connected via a heart-cut (H/C) device [19, 20] most commonly hyphenated with mass spectrometry.

Comprehensive two-dimensional GC consist of two columns with different selectivity connected via a heart-cut (H/C) modulation device [19] for transferring effluent from a first column to a second column. The modulation technique can be

conventionally applied allowing the comprehensive analysis within a single injection, and this 2DGC approach is widely recognized as GCxGC [21, 22] with the system configuration as shown in Figure 4.

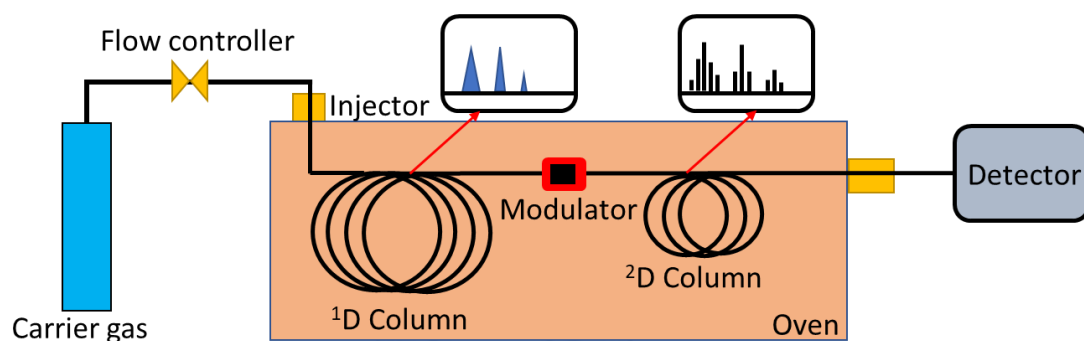

**Figure 4** Schematic diagram of GCxGC technique.

However, heart cut multidimensional chromatography (H/C MDGC) can be applied for increasing resolution and peak capacity based on the use of a long <sup>2</sup>D column (e.g. >20 m) with longer analysis time [3]. The heart-cut technique is generally hyphenated with FID and MS detectors. For untargeted compound analysis, the techniques is previously recognized as comprehensive H/C MDGC (CH/C MDGC) relying on multiple injections and multiple H/C strategies have been reported [8] with the system configuration as provided in Figure 5.

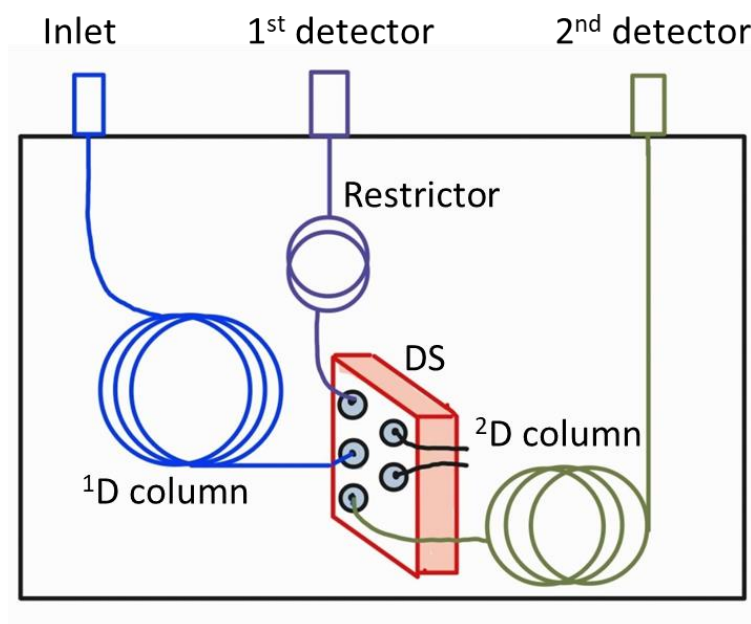

**Figure 5** The schematic diagram of CH/C 2DGC technique.

This offers improved separation performance (e.g. 2-10 times of the peak capacity obtained with GC×GC [12, 23] by using a longer <sup>2</sup>D column albeit with the expense of longer analysis time (e.g. as long as that applied in the stopped flow based comprehensive GC×GC analysis [24]). A compromise between the analysis time and the separation performance should thus be designed for analysis of each sample [12] [25]. CH/C analysis can be performed using both a Deans switch (DS) and a cryogenic trapping device (or cryogenic modulator) [12, 26]. Recently, a simpler system called as cryogen-free CH/C MDGC was also reported which employed a single DS without use of any cryogenic trapping device and was applied for analysis of perfume and petrochemical samples [23, 25, 27]. This approach applied a narrow H/C window (e.g. 0.2 min) to transfer a small sample pulse obtained from <sup>1</sup>D separation onto a <sup>2</sup>D column for enhanced separation performance.

## 2.5 Retention index

Retention indices ( $I$ ) are the scales indicating the position of different compound peaks in a chromatogram relative to the position of two adjacent

reference compounds (mostly *n*-alkane) eluting just before and after the target peak [28]. The range of the employed *n*-alkanes should cover the expected a retention time range of all target analytes of interest. For example, C<sub>8</sub> – C<sub>24</sub> alkanes were applied for untargeted identification of monoterpenes in a perfume sample based on the first and second dimensional *I* (<sup>1</sup>*I* and <sup>2</sup>*I*) [27]. In order to calculate *I* with temperature (*T*) programed 2DGC for a peak of interest, generation of positions of *n*-alkanes in a contour plot (isovolatility curve) is required.

## 2.6 Isovolatility curves

An isovolatility curve in 2DGC is a plot of <sup>2</sup>*t*<sub>R</sub> as a function of <sup>1</sup>*t*<sub>R</sub> of an alkane. Construction of isovolatility curves can be performed using relevant information from isothermal results at different *T* under the same experimental column arrangement. The first-dimensional retention indices of compounds (<sup>1</sup>*I*) are straight forward calculated by using <sup>1</sup>D elution time (<sup>1</sup>*t*<sub>R</sub>) of target compounds. However, second-dimensional retention index (<sup>2</sup>*I*) calculation is influenced by several experimental condition such as the second column length and elution temperature at <sup>1</sup>*t*<sub>R</sub>, because the *n*-alkanes and sample separation are complete in the <sup>1</sup>D column (longer column), but compounds with poor interaction with both columns eluted to detector before the others. This affects elution temperature of both alkane and the analyte peaks on the <sup>2</sup>D column.

The approach for construction of isovolatility curves could be performed by direct multiple injections of alkanes in GCxGC [29]. First, sample and the reference *n*-alkanes were injected (range of the employed *n*-alkanes should cover the expected <sup>1</sup>*t*<sub>R</sub> and <sup>2</sup>*t*<sub>R</sub> time ranges of all target compounds). Then, target compounds and *n*-alkanes underwent <sup>1</sup>D separation, moved to the modulator and underwent <sup>2</sup>D separation. Delayed multiple injections of the alkanes were then performed in order to vary the alkane <sup>2</sup>*t*<sub>R</sub> and generate the isovolatility curves. Because the <sup>2</sup>*t*<sub>R</sub> is much shorter than <sup>1</sup>*t*<sub>R</sub>, compounds were eluted under pseudo-isothermal condition in <sup>2</sup>D column. <sup>2</sup>*I* values were then calculated by using Kovats index. The analytes eluted

on the <sup>1</sup>D column under linear temperature program, <sup>1</sup>*I* values were then calculated according to van den Dool and Kratz relationship.

Wang et al. [30] developed the <sup>2</sup>*t*'<sub>R</sub>-<sup>2</sup>*T*<sub>e</sub> regression model to depict the relationship among adjusted second dimensional retention time (<sup>2</sup>*t*'<sub>R</sub>), temperature of <sup>2</sup>D column (<sup>2</sup>*T*<sub>e</sub>) and carbon number of *n*-alkanes (*N*) by using an exponential nonlinear function with only five parameters (*p*<sub>1</sub>-*p*<sub>5</sub>). This model can be applied to construct the isovolatility curves for <sup>2</sup>*I* calculation according to Equation 3.5.

## 2.7 Untargeted compound identification with 2DGC

Identification of peaks in GC×GC-MS result generally involves MS and <sup>1</sup>*I* library matches. <sup>1</sup>*I* can be calculated for a peak of interest by injection of *n*-alkanes followed by comparison of <sup>1</sup>D retention time (Identification of peaks in GC×GC-MS result generally involves MS and <sup>1</sup>*I* library matches. <sup>1</sup>*I* can be calculated for a peak of interest by injection of *n*-alkanes followed by comparison of <sup>1</sup>D retention time (<sup>1</sup>*t*<sub>R</sub>) of the peak and the alkanes CH/C MDGC can also apply the same <sup>1</sup>*I* calculation approach using the middle of the H/C for approximation of <sup>1</sup>*t*<sub>R</sub>. In addition, the peak identities can be confirmed according to comparison of experimental <sup>2</sup>*I* values with the experimental data. <sup>2</sup>*I* calculation with the single injection GC×GC can be based on construction of isovolatility curves (<sup>1</sup>*t*<sub>R</sub> vs <sup>2</sup>*t*<sub>R</sub> plots of the alkanes) by performing multiple injections of *n*-alkanes under the same temperature programs applied for analysis of samples. Alternatively, steps of different isothermal temperatures can be performed to generate the isovolatility curves on a <sup>2</sup>D column. <sup>2</sup>*I* calculation approach has also been reported for cryogen-free CH/C MDGC (also applicable with any other types of MDGC) using multi-location peak parking approach for construction of isovolatility curves. To this end, the least square curve fitting method can be performed using data obtained from 16 sets of automated injections of the alkanes for construction of their isovolatility curves [18]. A desirable goal is to establish a simpler method for <sup>2</sup>*I* calculation without additional alkane injection.

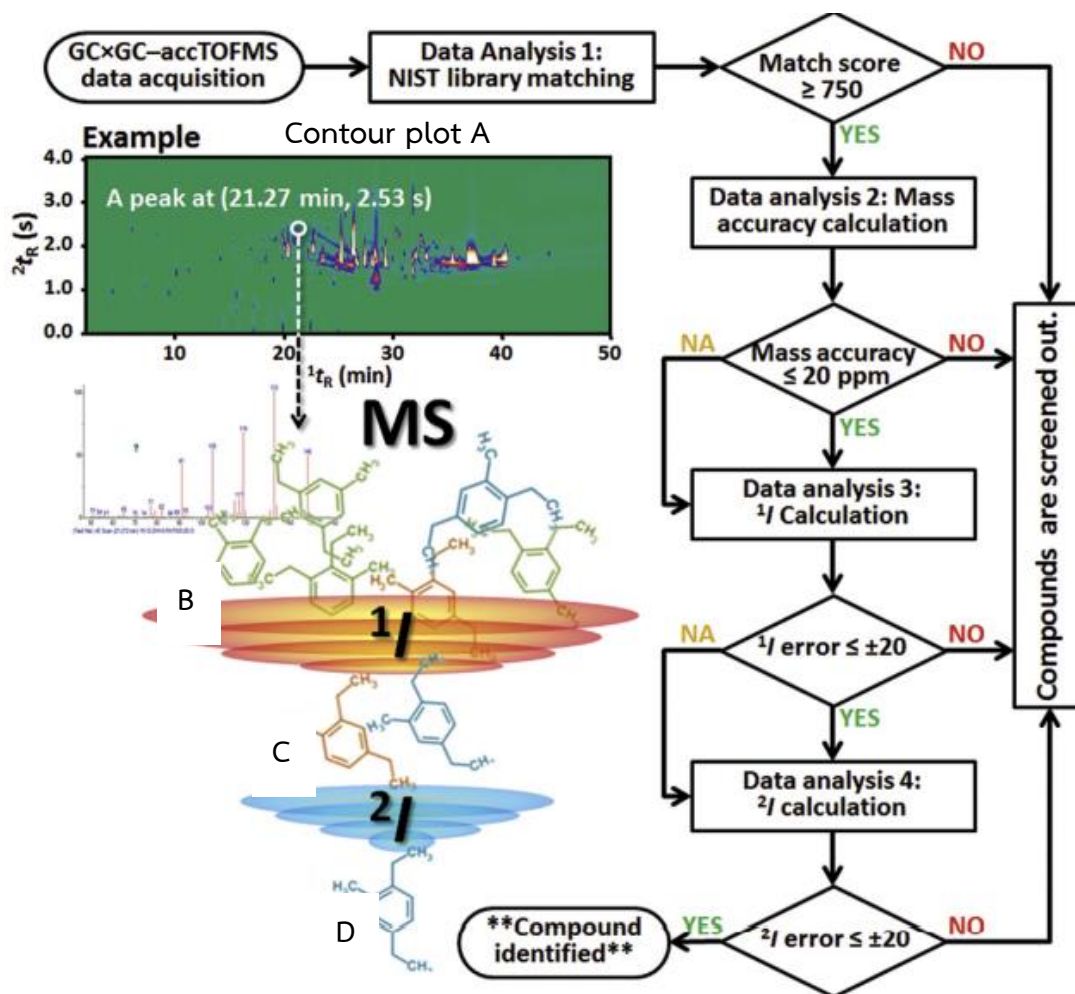

**Figure 6** Flowchart and diagram showing the process of compound confirmation in GCxGC-accurate mass time of flight MS, progressively applying MS library matches and retention index filters to refine the data [31].

A) Contour plot, B) Six isomers, C) Two isomers and D) Compound identified

Figure 6 shows an example identification of a peak of interest in a contour plot (A). The accurate mass time of flight MS result of this peak initially proposed six isomers (B): each of which gave a MS match score of  $>750$ , but with  $^1J$  revealing only two possible isomers (C) with retention indices within  $\pm 20$  compared with literature data.  $^2J$  was further applied to identify this peak as 1,4-diethyl-2-methyl-benzene (D).

## CHAPTER III

### EXPERIMENTAL

#### 3.1 Chemical and Sample preparation

A mixture of long chain alkane standards (C8-C20) was purchased from Sigma-Aldrich., LLC. (Singapore). These chemical standards were used to evaluate retention indices of <sup>1</sup>I and <sup>2</sup>I. The hexane was purchased RCI Labscan Limited co., Ltd. (USA). Green curry paste sample was purchased from a supermarket in Bangkok, Thailand. For sample preparation, the green paste sample (0.5 g) was dissolved in hexane (1.00 mL). The mixture was centrifuged for 2 min, and the supernatant was collected and filtered by PTFE 0.2 µm syringe filter prior to CH/C MDGC-MS analysis.

#### 3.2 Instrumentation and apparatus

All CH/C MDGC-MS experiments were performed on an Agilent 7890A GC and MS Model 7000 (CA, USA) using two analytical columns and a restrictor column (1.5 m x 0.1 mm; Agilent technologies Inc.). The first column (<sup>1</sup>D) and the second column (<sup>2</sup>D) were nonpolar HP-5MS capillary column (30 m x 0.25 mm x 0.25 µm; J&W Scientific, USA) and polar DB-WAX (60 m x 0.25 mm x 0.25 µm; J&W Scientific, USA), respectively. A Dean switch (DS, Agilent technologies Inc.) was applied as the interface connecting all the columns. In this study, DS was performed in on-modes to transfer eluent from <sup>1</sup>D column to FID, while off-mode from <sup>2</sup>D column to MS. The alkane mixture (100 ppm in hexane) or the sample was injected (1 µL, splitless) at injection port temperature of 240 °C. Constant flow rates of carrier gas (He 99.999% purity) on <sup>1</sup>D and <sup>2</sup>D columns were set at 2.0 and 4.0 mL/min, respectively. GC oven temperature program was set at 40 °C raised to 250 °C with the ramp rate of 6 °C/min (hold at 250 °C for 15 min) leading to the total runtime of 50 min. MS was operated in a full scan mode with ion source temperature of 250 °C, electron ionization voltage of -70 eV and mass ranges of 28-550 m/z. The total of injection was 25 runs and total time were 20.83 hr. In order to evaluate precision in value of <sup>2</sup>I

and peak area, the 4<sup>th</sup> and 11<sup>th</sup> injections were performed in 5 runs. The H/C events are shown in Table 1. For example, for the first injection run, the deans switch is started with an on-mode and then adjusted to off-/on-mode at 8.0/8.2 min, 13.0/13.2 min, 18.0/18.2 min, 23.0/23.2 min, 28.0/28.2 min, 33.0/33.2 min, 38.0/38.2 min, 43.0/43.2 min respectively.





**Table 1** The multiple H/C events cycle consisting of 25 runs.

Run 1	Run2		Run3		Run4		Run5		Run6		Run7		Run8		Run9		
8.0	Off	8.2	Off	8.4	Off	8.6	Off	8.8	Off	9.0	Off	9.2	Off	9.4	Off	9.6	Off
8.2	On	8.4	On	8.6	On	8.8	On	9.0	On	9.2	On	9.4	On	9.6	On	9.8	On
13.0	Off	13.2	Off	13.4	Off	13.6	Off	13.8	Off	14.0	Off	14.2	Off	14.4	Off	14.6	Off
13.2	On	13.4	On	13.6	On	13.8	On	14.0	On	14.2	On	14.4	On	14.6	On	14.8	On
18.0	Off	18.2	Off	18.4	Off	18.6	Off	18.8	Off	19.0	Off	19.2	Off	19.4	Off	19.6	Off
18.2	On	18.4	On	18.6	On	18.8	On	19.0	On	19.2	On	19.4	On	19.6	On	19.8	On
23.0	Off	23.2	Off	23.4	Off	23.6	Off	23.8	Off	24.0	Off	24.2	Off	24.4	Off	24.6	Off
23.2	On	23.4	On	23.6	On	23.8	On	24.0	On	24.2	On	24.4	On	24.6	On	24.8	On
28.0	Off	28.2	Off	28.4	Off	28.6	Off	28.8	Off	29.0	Off	29.2	Off	29.4	Off	29.6	Off
28.2	On	28.4	On	28.6	On	28.8	On	29.0	On	29.2	On	29.4	On	29.6	On	29.8	On
33.0	Off	33.2	Off	33.4	Off	33.6	Off	33.8	Off	34.0	Off	34.2	Off	34.4	Off	34.6	Off
33.2	On	33.4	On	33.6	On	33.8	On	34.0	On	34.2	On	34.4	On	34.6	On	34.8	On
38.0	Off	38.2	Off	38.4	Off	38.6	Off	38.8	Off	39.0	Off	39.2	Off	39.4	Off	39.6	Off
38.2	On	38.4	On	38.6	On	38.8	On	39.0	On	39.2	On	39.4	On	39.6	On	39.8	On
43.0	Off	43.2	Off	43.4	Off	43.6	Off	43.8	Off	44.0	Off	44.2	Off	44.4	Off	44.6	Off
43.2	On	43.4	On	43.6	On	43.8	On	44.0	On	44.2	On	44.4	On	44.6	On	44.8	On

**Table 1** The multiple H/C events cycle consisting of 25 runs. (Continued)

Run10	Run 11		Run12		Run13		Run14		Run15		Run16		Run17		
9.8	Off	10.0	Off	10.2	Off	10.4	Off	10.6	Off	10.8	Off	11.0	Off	11.2	Off
10.0	On	10.2	On	10.4	On	10.6	On	10.8	On	11.0	On	11.2	On	11.4	On
14.8	Off	15.0	Off	15.2	Off	15.4	Off	15.6	Off	15.8	Off	16.0	Off	16.2	Off
15.0	On	15.2	On	15.4	On	15.6	On	15.8	On	16.0	On	16.2	On	16.4	On
15.2	Off	20.0	Off	20.2	Off	20.4	Off	20.6	Off	20.8	Off	21.0	Off	21.2	Off
20.0	On	20.2	On	20.4	On	20.6	On	20.8	On	21.0	On	21.2	On	21.4	On
24.8	Off	25.0	Off	25.2	Off	25.4	Off	25.6	Off	25.8	Off	26.0	Off	26.2	Off
25.0	On	25.2	On	25.4	On	25.6	On	25.8	On	26.0	On	26.2	On	26.4	On
29.8	Off	30.0	Off	30.2	Off	30.4	Off	30.6	Off	30.8	Off	31.0	Off	31.2	Off
30.0	On	30.2	On	30.4	On	30.6	On	30.8	On	31.0	On	31.2	On	31.4	On
34.8	Off	35.0	Off	35.2	Off	35.4	Off	35.6	Off	35.8	Off	36.0	Off	36.2	Off
35.0	On	35.2	On	35.4	On	35.6	On	35.8	On	36.0	On	36.2	On	36.4	On
39.8	Off	40.0	Off	40.2	Off	40.4	Off	40.6	Off	40.8	Off	41.0	Off	41.2	Off
40.0	On	40.2	On	40.4	On	40.6	On	40.8	On	41.0	On	41.2	On	41.4	On
44.8	Off	45.0	Off	45.2	Off	45.4	Off	45.6	Off	45.8	Off	46.0	Off	46.2	Off
45.0	On	45.2	On	45.4	On	45.6	On	45.8	On	46.0	On	46.2	On	46.4	On

**Table 1** The multiple H/C events cycle consisting of 25 runs. (Continued)

Run18	Run19		Run20		Run 21		Run22		Run23		Run24		Run25		
11.4	Off	11.6	Off	11.8	Off	10.0	Off	10.2	Off	10.4	Off	10.6	Off	10.8	Off
11.6	On	11.8	On	12.0	On	10.2	On	10.4	On	10.6	On	10.8	On	11.0	On
16.4	Off	16.6	Off	16.8	Off	15.0	Off	15.2	Off	15.4	Off	15.6	Off	15.8	Off
16.6	On	16.8	On	17.0	On	15.2	On	15.4	On	15.6	On	15.8	On	16.0	On
21.4	Off	21.6	Off	21.8	Off	20.0	Off	20.2	Off	20.4	Off	20.6	Off	20.8	Off
21.6	On	21.8	On	22.0	On	20.2	On	20.4	On	20.6	On	20.8	On	21.0	On
26.4	Off	26.6	Off	26.8	Off	25.0	Off	25.2	Off	25.4	Off	25.6	Off	25.8	Off
26.6	On	26.8	On	27.0	On	25.2	On	25.4	On	25.6	On	25.8	On	26.0	On
31.4	Off	31.6	Off	31.8	Off	30.0	Off	30.2	Off	30.4	Off	30.6	Off	30.8	Off
31.6	On	31.8	On	32.0	On	30.2	On	30.4	On	30.6	On	30.8	On	31.0	On
36.4	Off	36.6	Off	36.8	Off	35.0	Off	35.2	Off	35.4	Off	35.6	Off	35.8	Off
36.6	On	36.8	On	37.0	On	35.2	On	35.4	On	35.6	On	35.8	On	36.0	On
41.4	Off	41.6	Off	41.8	Off	40.0	Off	40.2	Off	40.4	Off	40.6	Off	40.8	Off
41.6	On	41.8	On	42.0	On	40.2	On	40.4	On	40.6	On	40.8	On	41.0	On
46.4	Off	46.6	Off	46.8	Off	45.0	Off	45.2	Off	45.4	Off	45.6	Off	45.8	Off
46.6	On	46.8	On	47.0	On	45.2	On	45.4	On	45.6	On	45.8	On	46.0	On

### 3.3 Data analysis

#### 3.3.1 Identification of volatile compounds

GC–MS and CH/C MDGC–MS identification of the volatile compound in green curry paste was performed using Agilent MassHunter software. A peak of interest was identified based on comparison of the experimental MS spectrum with standard MS spectra from the NIST17 library. The identification criteria were assigned with a match score of >650 and a difference in the experimental and literature values of  $I$  at  $\pm 40$  for  $^1I$  on the  $^1D$  semi nonpolar columns and  $\pm 60$  for  $^2I$  on  $^2D$  polar column. However, that only the compounds without the literature data were identified  $^2I$  without confirmation. The experimental  $^1I$  and  $^2I$  were evaluated based on the Van den Dool and Kratz and Kovats [32] relationship, respectively. The results were further processed using Microsoft Excel.

#### 3.3.2 Calculation of $^1t_R$ , $^2t_R$ and $^1I$

The  $^1t_R$  and  $^2t_R$  values of a peak detected by MS in each H/C MDGC analysis were calculated as

$$^1t_R = t_{H/Cmid} = \frac{t_{H/C}}{2} = \frac{t_{H/Cstart} + t_{H/Cend}}{2} \quad (3.1)$$

Where  $t_{H/C}$  is the H/C window.  $t_{H/Cmid}$ ,  $t_{H/Cstart}$  and  $t_{H/Cend}$  are the middle time, starting time and ending time of the H/C, respectively.

$$^2t_R = t_{observed} - ^1t_R \quad (3.2)$$

$t_{observed}$  is the peak time observed with MS (after elution through  $^1D$  and  $^2D$  columns). When a peak of a compound was modulated into several sub-peaks in different H/C events and  $^1t_R$  values of this compound was obtained by the H/C heartcut events.

<sup>1</sup><sub>I</sub> was calculated using the Van den dool and Kratz index relationship

$$I = 100n + 100 \left[ \frac{t_{R(i)} - t_{R(n)}}{t_{R(n+1)} - t_{R(n)}} \right] \quad (3.3)$$

Where  $t_R$  is the total retention time of <sup>1</sup>D and <sup>2</sup>D columns and  $n$  and  $n+1$  are the number of carbons of alkane standards.

### 3.3.3 Building of isovolatility curves using multi location peak parking

Experiments for 16 sets were performed with each set of 4 sequences: two sequences for peak parking and another two sequences for elution with DS on-mode and off-mode as shown in Table 2.

**Table 2** The set of multi-location peak parking for building isovolatility curves

No.	Run No.	Injection	Temperature program
Set 1	Parking	<i>n</i> -alkane standards	35 °C to 100 °C with ramp rate 20 °C/min
	Run-on	blank vial	The same with green curry in on mode
	Parking	<i>n</i> -alkane standards	35 °C to 100 °C with ramp rate 20 °C/min
	Run -off	blank vial	The same with green curry in off mode
Set 2	Parking	<i>n</i> -alkane standards	35 °C to 120 °C with ramp rate 20 °C/min
	Run-on	blank vial	The same with green curry in on mode
	Parking	<i>n</i> -alkane standards	35 °C to 120 °C with ramp rate 20 °C/min
	Run -off	blank vial	The same with green curry in off mode
Set 3	Parking	<i>n</i> -alkane standards	35 °C to 140 °C with ramp rate 20 °C/min
	Run-on	blank vial	The same with green curry in on mode
	Parking	<i>n</i> -alkane standards	35 °C to 140 °C with ramp rate 20 °C/min
	Run -off	blank vial	The same with green curry in off mode
Set 4	Parking	<i>n</i> -alkane standards	35 °C to 160 °C with ramp rate 20 °C/min
	Run-on	blank vial	The same with green curry in on mode
	Parking	<i>n</i> -alkane standards	35 °C to 160 °C with ramp rate 20 °C/min
	Run -off	blank vial	The same with green curry in off mode
Set 5	Parking	<i>n</i> -alkane standards	35 °C to 180 °C with ramp rate 20 °C/min
	Run-on	blank vial	The same with green curry in on mode
	Parking	<i>n</i> -alkane standards	35 °C to 180 °C with ramp rate 20 °C/min
	Run -off	blank vial	The same with green curry in off mode
Set 6	Parking	<i>n</i> -alkane standards	35 °C to 200 °C with ramp rate 20 °C/min
	Run-on	blank vial	The same with green curry in on mode

No.	Run No.	Injection	Temperature program
	Parking Run -off	<i>n</i> -alkane standards blank vial	35 °C to 200 °C with ramp rate 20 °C/min The same with green curry in off mode
Set 7	Parking Run-on Parking Run -off	<i>n</i> -alkane standards blank vial <i>n</i> -alkane standards blank vial	35 °C to 220 °C with ramp rate 20 °C/min The same with green curry in on mode 35 °C to 220 °C with ramp rate 20 °C/min The same with green curry in off mode
Set 8	Parking Run-on Parking Run -off	<i>n</i> -alkane standards blank vial <i>n</i> -alkane standards blank vial	35 °C to 240 °C with ramp rate 20 °C/min The same with green curry in on mode 35 °C to 240 °C with ramp rate 20 °C/min The same with green curry in off mode
Set 9	Parking Run-on Parking Run -off	<i>n</i> -alkane standards blank vial <i>n</i> -alkane standards blank vial	35 °C to 240 °C with ramp rate 20 °C/min and hold 2 min The same with green curry in on mode 35 °C to 240 °C with ramp rate 20 °C/min and hold 2 min The same with green curry in off mode
Set 10	Parking Run-on Parking Run -off	<i>n</i> -alkane standards blank vial <i>n</i> -alkane standards blank vial	35 °C to 240 °C with ramp rate 20 °C/min and hold 4 min The same with green curry in on mode 35 °C to 240 °C with ramp rate 20 °C/min and hold 4 min The same with green curry in off mode
Set 11	Parking Run-on Parking Run -off	<i>n</i> -alkane standards blank vial <i>n</i> -alkane standards blank vial	35 °C to 240 °C with ramp rate 20 °C/min and hold 6 min The same with green curry in on mode 35 °C to 240 °C with ramp rate 20 °C/min and hold 6 min The same with green curry in off mode
Set 12	Parking Run-on Parking Run -off	<i>n</i> -alkane standards blank vial <i>n</i> -alkane standards blank vial	35 °C to 240 °C with ramp rate 20 °C/min and hold 8 min The same with green curry in on mode 35 °C to 240 °C with ramp rate 20 °C/min and hold 8 min The same with green curry in off mode
Set 13	Parking Run-on Parking	<i>n</i> -alkane standards blank vial <i>n</i> -alkane standards	35 °C to 240 °C with ramp rate 20 °C/min and hold 10 min The same with green curry in on mode 35 °C to 240 °C with ramp rate 20 °C/min

No.	Run No.	Injection	Temperature program
	Run -off	blank vial	and hold 10 min The same with green curry in off mode
Set 14	Parking	<i>n</i> -alkane standards	35 °C to 240 °C with ramp rate 20 °C/min and hold 12 min
	Run-on	blank vial	The same with green curry in on mode
	Parking	<i>n</i> -alkane standards	35 °C to 240 °C with ramp rate 20 °C/min and hold 12 min
	Run -off	blank vial	The same with green curry in off mode
Set 15	Parking	<i>n</i> -alkane standards	35 °C to 240 °C with ramp rate 20 °C/min and hold 14 min
	Run-on	blank vial	The same with green curry in on mode
	Parking	<i>n</i> -alkane standards	35 °C to 240 °C with ramp rate 20 °C/min and hold 14 min
	Run -off	blank vial	The same with green curry in off mode
Set 16	Parking	<i>n</i> -alkane standards	35 °C to 240 °C with ramp rate 20 °C/min and hold 16 min
	Run-on	blank vial	The same with green curry in on mode
	Parking	<i>n</i> -alkane standards	35 °C to 240 °C with ramp rate 20 °C/min and hold 16 min
	Run -off	blank vial	The same with green curry in off mode

Steps for establishing isovolatility curves are the followings as shown in Figure 3.1.

1. The first two sequences were executed for peak parking to FID. First, *n*-alkanes were injected and separation with temperature program was set to elute *n*-alkanes with different position on a <sup>1</sup>D column. Second, blank was injected with same temperature program to elute *n*-alkanes to FID.
2. Like the first sequence, third, *n*-alkanes were injected for peak parking and separation with temperature program was set to elute *n*-alkanes with different position on a <sup>1</sup>D column. Forth, blank was injected with same temperature program to elute *n*-alkanes to MS.

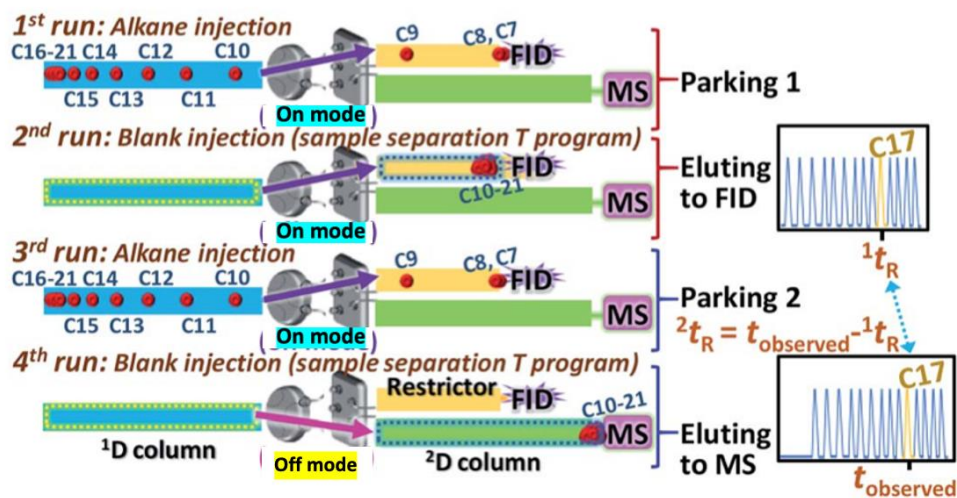

Figure 7 The process of multiple peak parking with 1<sup>st</sup>, 2<sup>nd</sup>, 3<sup>rd</sup> and 4<sup>th</sup> sequences of n-alkane to establish isovolatility curves [27].

### 3.3.4 Improved sample identification using isovolatility curve and ${}^2t_R$ calculation.

For a regression model, the isovolatility curve construction was calculated to approximate  ${}^2t_R$  of the n-alkane references as shown in equation (3.4)

$${}^2t'_R = \exp(\exp(p_1 \times {}^2T_e + p_2) \times N + \exp(p_3 + {}^2T_e + p_4) + p_5) \quad (3.4)$$

Where  ${}^2t'_R$  is calculated  ${}^2t_R$ .  ${}^2T_e$  is elution temperature on the  ${}^2D$  columns calculating from  ${}^2T_e = \gamma^1t_R + T_0$  with  ${}^2T_e \leq$  final temperature,  $\gamma$  = temperature increasing rate and  $T_0$  = starting oven temperature.  $P_{1-5}$  values are constants obtained from the least square curve fitting (using Solver in Microsoft Excel) between the experimental  ${}^2t_R$  and the  ${}^2t_{R,cal}$  data with the same  ${}^1t_R$  along the isovolatility curves of alkanes with the carbon numbers of  $N$  ( $N = 8, 9, 10, \dots, 18, 19$  and  $20$ ) as shown in Appendix 1.

After calculation of  ${}^1t_R$  and  ${}^2t_R$  for a peak of interest, equation 3.4 was applied to approximate  ${}^2t_R$  of the n-alkane references eluting at  ${}^1t_R$  of the peak under the same experimental conditions applied for the green curry sample. Kovats relationship was then used to calculate  ${}^2I$  of this peak with the relationship.



<sup>2</sup><sub>R</sub> calculation was according to

$$I = 100n + 100 \left[ \frac{\log {}^2t_{R(i)} - \log {}^2t_{R(n)}}{\log {}^2t_{R(n+1)} - \log {}^2t_{R(n)}} \right] \quad (3.5)$$

<sup>2</sup><sub>R(i)</sub> is a <sup>2</sup><sub>R</sub> of the peak, <sup>2</sup><sub>R(n)</sub> and <sup>2</sup><sub>R(n+1)</sub> are the alkane which was eluted before/after the peak, respectively



## CHAPTER IV

### RESULT AND DISCUSSION

#### 4.1 CH/C-MDGC-MS analysis of green curry paste extract

The green curry paste sample was analyzed using a cryogenic free CH/C-MDGC-MS approach. All peaks of volatile compounds in green curry paste were obtained from <sup>1</sup>D separation using H/C with the constant window of 0.2 min prior to <sup>2</sup>D separation. Cyclic multiple H/C strategy and multiple injections were applied [25] with <sup>2</sup>D separation time of 5 min is approximated by heartcutting several fractions from <sup>1</sup>D chromatogram to undergo <sup>2</sup>D separation at different <sup>1</sup>D time and observing the time that each peak spent on the <sup>2</sup>D column showing most of the peaks eluting within 5 min. This required 25 injections was calculated from <sup>2</sup>D separation time of 5 min divided by the constant 0.2 min H/C window with the total analysis time of 20.83 hr. This involved cyclic 8 H/C events per each injection to cover the comprehensive analysis range of 8-48 min of the <sup>1</sup>D chromatogram. An example of periodic H/C chromatograms of first three injections is shown in Figure 8. In <sup>1</sup>D separation, a particular compound elutes with one peak in a chromatogram. However, with cyclic 8 H/C events and 25 injections for CH/C MDGC in this work, H/C with the constant 0.2 min window may provide a particular compound to appear its peaks in different chromatograms for consequent injections.

The identification criteria were assigned with a match score of >650 and a difference in the experimental and literature values of *I* at  $\pm 40$  for <sup>1</sup>*I* on the <sup>1</sup>D nonpolar columns and  $\pm 60$  for <sup>2</sup>*I* on <sup>2</sup>D polar column. These differences could be obtained by adding the H/C window consideration into the conventional limit of  $\pm 30$  in <sup>1</sup>*I* and <sup>2</sup>*I* as already described in [33].

Lists of volatile compounds identified are shown with criteria of MS matching scores of >650 and <sup>1</sup>*I* as shown in Table 3 and both values of <sup>1</sup>*I* and <sup>2</sup>*I* as shown in Table 4. As seen in Table 3, 93 volatile compounds were identified based on MS

matching. However, 87 identified volatile compounds were confirmed based on MS matching and  $^1I$ , while 35 identified volatile compounds in Table 4 were confirmed based on MS matching and both values of  $^1I$  and  $^2I$  and 7 volatile compounds without the literature data were identified  $^2I$  without confirmation. Caused by the CH/C process in an MS full scan mode that a particular compound may provide peaks in different chromatograms for consequent injections, a peak area percentage is based on the total peak areas, where the peak area of each compound is a sum of peak area of all the sub-peaks of the same compound obtained from chromatograms for consequent injections, and the total peak area is a sum of all peaks in all chromatograms with cyclic 8 H/C events and 25 injections.

For an example of the eleventh compound in Table 4, the peak time of 18.43 min observed with MS ( $t_{\text{observed}}$ ) is sum of  $^1t_{\text{R}}$  and  $^2t_{\text{R}}$  as previously mentioned in Equation 3.2. where the  $^1t_{\text{R}}$  and  $^2t_{\text{R}}$  values of 13.10 and 5.33 min are calculated using Equations 3.1 and 3.2, respectively. It should be noted that the peak at  $t_{\text{observed}}$  of 18.43 min may be eluted from  $^1D$  column with the possible H/C event of 8.00-8.20 and 13.00-13.20 min giving possible  $^1I$  of 987 and 1089, respectively. This takes into account the possible heartcut events corresponding to the peak of interest. However, no compound in NIST 17 data library meets criteria with  $^1I$  of  $987 \pm 40$  and MS matching at least 650, while experimental  $^1I$  of 1089 is consistent with literature  $^1I$  of 1088 for terpinolene together with MS matching of 865. Therefore, the peak at  $t_{\text{observed}}$  of 18.43 min has the experimental  $^1I$  of 1089 with the possible H/C event of 13.00 to 13.20 min for  $t_{\text{H/Cstart}}$  to  $t_{\text{H/Cend}}$ . This gives  $t_{\text{H/Cmid}}$  or  $^1t_{\text{R}}$  of 13.10 min and  $^2t_{\text{R}}$  of 5.33 min. Using Equation 3.4 and 3.5, the  $^2t_{\text{R}}$  value of 5.33 min gives experimental  $^2I$  of 1331 that is consistent with literature  $^2I$  of 1283 for terpinolene. By confirming with the criteria of MS matching at least 650,  $^1I$  within  $\pm 40$  and  $^2I$  within  $\pm 60$ , the peak at  $t_{\text{observed}}$  of 18.43 min is identified to be terpinolene.

It should be noted from Appendix 3 results of our research group that 1DGC-MS analysis of green curry paste showed 41 volatile compounds along with 7 compounds that was found in using CH/C MDGCMS in this work:  $\gamma$ -terpinene, linalool, terpinen-4-ol,  $\alpha$ -terpineol,  $\beta$ -bisabolene,  $\alpha$ -farnesene and  $\alpha$ R-turmerone

Table in Appendix 2 shows values of  $^2I$  and peak area obtained from the 4<sup>th</sup> and 11<sup>th</sup> injections in 5 runs to calculate relative standard deviation (%RSD). Acceptable precision in values of  $^2I$  and peak area was obtained with RSD values of <0.11 and <3.3% for  $^2I$  and the peak area, respectively.

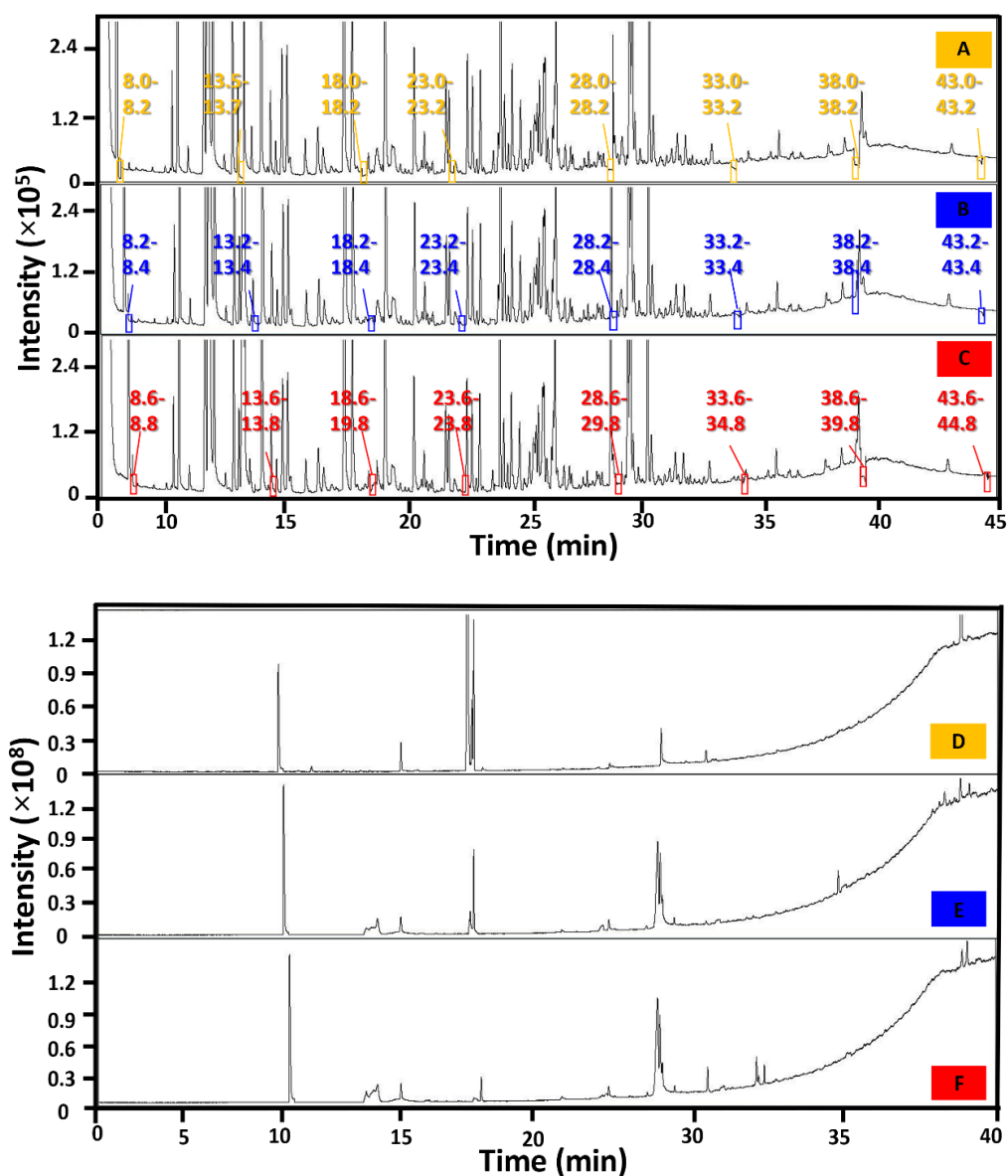

**Figure 8** CH/C 2DGC chromatograms of the green curry paste sample from 1<sup>st</sup>, 2<sup>nd</sup> and 3<sup>rd</sup> injections for  $^1D$  separation-FID of A, B and C resulting in  $^1D + ^2D$  separation-MS showing D, E and F, respectively.

**Table 3** Volatile compound profiles with literature/experimental retention indices and MS match scores of the green curry paste sample analyzed by CH/C 2DGC-MS.

No.	$t_{\text{observed}}$ (min)	$^2t_{\text{r}}$ (min)	Compound	CAS number	% Area	MS match	$I_{\text{lit}}/I_{\text{exp}}^a$	$\Delta I$
1	11.66	3.56	Unknown		0.37		-/842	
2	13.49	5.39	Unknown		0.02		-/842	
3	13.73	5.43	Unknown		0.43		-/858	
4	13.87	4.17	$\alpha$ -thujene	2867-05-2	0.39	892	929/941	12
5	14.10	3.80	$\alpha$ -pinene	80-56-8	1.66	860	937/969	14
6	14.80	4.30	camphene	79-92-5	0.08	702	952/979	27
7	14.99	2.90	cyclopropylbenzene	873-49-4	8.44	816	1032/1048	16
8	15.00	4.10	1-propenylbenzene	766-90-5	0.32	821	934/998	13
9	15.65	4.40	sabinene	3387-41-5	3.21	874	974/1015	32
10	15.77	4.47	limonene	127-91-3	0.23	795	1030/1015	-15
11	15.84	3.94	4-methylene-1-(1-methylethyl)- cyclohexane	99-84-3	0.72	857	1182/1039	11
12	16.03	4.93	$\beta$ -phellandrene	555-10-2	1.51	792	1031/1006	-25
13	16.06	4.36	$\beta$ -myrcene	123-35-3	1.36	922	991/1031	40

**Table 3** Volatile compound profiles with literature/experimental retention indices and MS match scores of the green curry paste sample analyzed by CH/C 2DGC-MS. (Continued)

No.	$t_{\text{observed}}$ (min)	$^2t_{\text{r}}$ (min)	Compound	CAS number	% Area	MS match	$I_{\text{lit}}/I_{\text{exp}}^a$	$\Delta I$
14	16.67	5.17	$\alpha$ -phellandrene	99-82-2	0.07	783	1005/1023	18
15	16.87	3.17	2,4,6-trimethyl-decane	62108-27-4	1.05	712	1121/1114	-7
16	17.03	4.53	$\beta$ -terpinene	99-84-3	1.21	782	1028/1064	36
17	17.48	4.78	$\alpha$ -ocimene	502-99-8	8.05	748	1047/1073	26
18	17.59	5.09	$\gamma$ -terpinene	99-85-4	1.59	767	1060/1064	4
19	17.64	7.34	2-thujene	18767-59-4	0.38	877	966/969	3
20	17.73	4.43	trans-sabinene hydrate	7712-82-5	0.53	721	1070/1097	27
21	17.88	4.18	Unknown		0.12		-/1114	
22	17.90	7.20	sulcatone	110-93-0	0.47	904	986/988	2
23	17.99	5.49	2-ethyl- <i>p</i> -xylene	1758-88-9	0.58	865	1074/1064	-10
24	18.00	6.30	trans- $\beta$ -ocimene	3779-61-1	0.21	877	1049/1031	-18
25	18.04	4.94	2-ethyl-1,4-dimethyl- benzene	1758-88-9	0.03	835	1074/1089	10
26	18.43	5.33	terpinolene	586-62-9	3.09	865	1088/1089	1
27	19.05	5.15	benzenepropanal	104-53-0	3.26	765	1162/1122	-40
28	19.39	9.69	terpinolene	586-62-9	0.54	909	1088/1064	-24
29	20.69	7.99	cis-linalool oxide	1365-19-1	0.81	875	1074/1073	-1

**Table 3** Volatile compound profiles with literature/experimental retention indices and MS match scores of the green curry paste sample analyzed by CH/C 2DGC-MS. (Continued)

No.	$t_{\text{observed}}$ (min)	$^2t_{\text{r}}$ (min)	Compound	CAS number	% Area	MS match	$I_{\text{lit}}/I_{\text{exp}}^a$	$\Delta I$
30	20.79	6.69	<i>p</i> -menth-8-en-1-ol, stereoisomer	7299-40-3	0.39	837	1161/1130	-31
31	21.02	12.52	2-heptanol	543-49-7	0.04	690	900/874	-26
32	21.27	8.57	trans-linalool 3,7-oxide	34995-77-2	0.23	849	1086/1073	-13
33	21.45	7.15	(1 <i>Z</i> )-1-propen-1-yl 2-propen-1-yl disulfide	23838-20-2	0.17	738	1107/1139	32
34	21.83	7.73	(1 <i>E</i> )-1-propen-1-yl2-propen-1-yl disulfide	122156-02-9	0.04	764	1103/1130	27
35	21.97	8.67	linalool	78-70-6	0.76	892	1099/1097	-2
36	22.41	7.51	cis-2- <i>p</i> -menthen-1-ol	35376-39-7	0.05	680	1161/1163	2
37	22.78	9.68	acetophenone	98-86-2	0.84	835	1065/1089	24
38	22.75	8.28	1-phenyl-1,2-propanedione	579-07-7	0.03	755	1175/1147	-28
39	22.94	8.44	isopulegol	89-79-2	0.21	682	1146/1147	1
40	23.05	3.35	2,6,10-trimethyl-dodecane	3891-98-3	0.05	732	1366/1371	15
41	23.61	4.51	N,N-diethyl-4-methyl-benzenamine	613-48-9	0.06	769	1343/1344	1
42	23.60	8.86	di-isopulegol	50373-36-9	0.09	684	1163/1134	-29
43	24.00	7.70	Unknown		0.04	770	-/1222	

**Table 3** Volatile compound profiles with literature/experimental retention indices and MS match scores of the green curry paste sample analyzed by CH/C 2DGC-MS. (Continued)

No.	t <sub>observed</sub> (min)	<sup>2</sup> t <sub>tr</sub> (min)	Compound	CAS number	% Area	MS match	I <sub>lit</sub> /I <sub>exp</sub> <sup>a</sup>	ΔI
44	24.27	9.17	terpinen-4-ol	20126-76-5	5.30	855	1177/1171	-6
45	24.30	6.60	Unknown				-/1282	
46	24.58	6.68	4-ethyl-3-methylphenol	1123-94-0	0.10	705	1237/1209	-28
47	24.69	8.59	dimethyl acetal benzaldehyde	1125-88-8	0.41	721	1200/1239	39
48	24.70	11.60	α, α-dimethyl-benzene methanol	617-94-7	1.77	822	1090/1089	-1
49	24.97	8.67	2-1-methylethylphenol	88-69-7	0.02	662	1199/1222	23
50	25.15	2.25	2-(1-methylethyl), methylcarbamate phenol	2631-40-5	0.13	673	1532/1525	-7
51	25.31	11.41	1-ethyl-4-methoxy- benzene	1515-95-3	0.15	707	1110/1122	12
52	25.46	5.76	1-(4-methoxyphenyl)- 2-propanone	122-84-9	0.34	659	1384/1371	-13
53	25.51	10.41	α-terpineol	98-55-5	1.18	838	1189/1171	-18
54	25.53	8.23	α, α,4-trimethyl-3-cyclohexene-1- methanethiol	71159-90-5	1.12	694	1283/1265	-18
55	26.09	5.19	β-cubebene	13744-15-5	0.04	682	1389/1481	29
56	26.38	12.28	tetrahydro-4-methyl-2-(2-methyl-1- propenyl)-2H-pyran	16409-43-1	0.15	676	1110/1130	20
57	26.48	10.18	citronellol	106-22-9	0.22	710	1228/1239	11
58	26.92	12.42	trans-verbenol	1820-09-3	0.41	660	1144/1147	3
59	26.99	6.89	copaene	3856-25-5	0.95	870	1376/1389	13



**Table 3** Volatile compound profiles with literature/experimental retention indices and MS match scores of the green curry paste sample analyzed by CH/C 2DGC-MS. (Continued)

No.	$t_{\text{observed}}$ (min)	$^2t_{\text{r}}$ (min)	Compound	CAS number	% Area	MS match	$I_{\text{lit}}/I_{\text{exp}}^a$	$\Delta I$
60	27.03	7.53	citronellol acetate	150-84-5	0.60	808	1354/1362	8
61	27.42	4.72	germacrene	23986-74-5	0.71	712	1481/1514	33
62	27.43	7.13	$\beta$ -cubebene	13744-15-5	8.73	734	1389/1399	10
63	27.45	6.95	$\beta$ -copaene	18252-44-3	0.57	683	1432/1408	-24
64	27.63	8.73	mesitaldehyde	487-68-3	2.83	696	1337/1335	-2
65	27.72	6.22	$\gamma$ -elemene	29873-99-2	0.37	681	1433/1456	23
66	27.72	5.02	1,2,3,5,6,7,8,8a-octahydro-1,4-dimethyl-7-(1-methylethenyl)-, [1S-(1 $\alpha$ ,7 $\alpha$ ,8 $\alpha$ )]-azulene	3691-11-0	0.14	701	1505/1514	9
67	27.87	11.17	geraniol	106-24-1	1.03	717	1255/1239	-16
68	27.97	8.87	1,2-diol limonene	1946-00-5	0.13	685	1321/1344	23
69	28.31	5.81	$\beta$ -guaiene	88-84-6	0.25	702	1490/1504	14
70	28.34	7.24	neryl propanoate	105-91-9	0.77	766	1455/1437	-18
71	28.39	9.89	$\alpha$ -cubebene	17699-14-8	0.92	721	1351/1317	-34
72	28.41	5.71	$\alpha$ -farnesene	502-61-4	0.83	826	1508/1514	6
73	28.63	6.13	valencene	4630-07-3	1.59	792	1492/1504	12

**Table 3** Volatile compound profiles with literature/experimental retention indices and MS match scores of the green curry paste sample analyzed by CH/C 2DGC-MS. (Continued)

No.	$t_{\text{observed}}$ (min)	$^2t_{\text{R}}$ (min)	Compound	CAS number	% Area	MS match	$I_{\text{lit}}/I_{\text{exp}}^a$	$\Delta I$
75	28.77	4.87	(1E,5E)-1,5-cyclododecadiene, 1,5-	15423-57-1	0.38	773	1557/1575	18
76	28.84	5.94	dimethyl-8-(1-methylethylidene) $\beta$ -bisabolene	495-61-4	0.69	707	1509/1525	16
77	29.72	6.62	trans- $\alpha$ -bisabolene	70286-32-7	0.48	673	1512/1535	23
78	30.00	10.10	copaene	3856-25-5	0.18	776	1376/1344	-32
79	30.16	9.26	$\alpha$ -cedrene	469-61-4	0.22	680	1411/1427	15
80	30.45	7.55	$\beta$ -sesquiphellandrene	20307-83-9	0.57	679	1524/1525	1
81	30.65	8.35	$\beta$ -eudesmene	17066-67-0	0.21	728	1486/1494	-8
82	30.76	8.46	$\alpha$ -selinene	515-17-3	0.15	686	1494/1494	0
83	31.06	10.16	cedrene	19069-48-8	0.37	666	1422/1427	5
84	31.13	7.83	$\alpha$ -cadinene	24406-05-1	0.92	747	1538/1545	7
85	31.17	9.67	$\gamma$ -muurolene	30021-74-0	0.38	679	1477/1456	-21
86	31.35	8.85	2-methylpropionate cumyl alcohol	536-60-7	0.33	680	1511/1504	-7
87	32.92	9.02	cetene	629-73-2	0.37	725	1592/1575	-17
88	35.89	11.79	carotol	465-28-1	0.33	682	1594/1585	-9

**Table 3** Volatile compound profiles with literature/experimental retention indices and MS match scores of the green curry paste sample analyzed by CH/C 2DGC-MS. (Continued)

No.	$t_{\text{observed}}$ (min)	$^2t_{\text{R}}$ (min)	Compound	CAS number	% Area	MS match	$I_{\text{lit}}/I_{\text{exp}}^a$	$\Delta I$
89	35.91	12.61	ledol	577-27-5	3.07	778	1565/1585	20
90	36.83	12.53	spirojatamol	128487-46-7	0.16	761	1592/1596	4
91	37.07	11.73	aR-tumerone	532-65-0	0.11	687	1664/1649	-15
92	37.25	13.15	globulol	489-41-8	0.48	822	1580/1585	5
93	37.47	12.37	tumerone	180315-67-7	14.90	717	1632/1638	6

$I_{\text{lit}}$  and  $I_{\text{exp}}$  refer to the values of literature and experimental indices

**Table 4** Volatile compound profiles with literature/experimental retention indices of  $^1I$ ,  $^2I$  and MS match scores of the green curry paste sample analyzed by CH/C 2DGC-MS.

No.	$t_{\text{observed}}$ (min)	$^2t_{\text{R}}$ (min)	Compound	CAS number	%PA	MS match	$\Delta^1 I$	$z_{\text{lit}}/z_{\text{exp}}^b$	$\Delta^2 I$	found ingredient
1	13.87	4.17	$\alpha$ -thujene	2867-05-2	0.39	892	12	1028/1088	60	Gal [2] K[1]
2	14.10	4.11	$\alpha$ -pinene	7785-70-8	1.66	860	14	1028/1081	52	Gal [2], Gre [4]
3	14.80	4.30	camphene	79-92-5	0.08	702	27	1071/1128	57	Gal [2]
4	15.65	4.40	sabinene	3387-41-5	3.21	874	32	1124/1165	41	Gre [4]
5	15.77	4.47	$\beta$ -pinene	127-91-3	0.23	795	36	1211/1176	35	Gre [4] Gal [2]
6	16.03	4.93	$\beta$ -phellandrene	555-10-2	1.51	792	-25	1211/1231	20	K [6]
7	16.06	4.36	myrcene	123-35-3	1.36	922	40	1161/1169	8	Gal [2], L [2]
8	17.03	4.53	$\beta$ -terpinene	99-84-3	1.21	782	36	1212/1218	6	K[1]
9	17.48	4.78	$\alpha$ -ocimene	502-99-8	8.05	748	26	1245/1257	12	L [2]
10	17.59	5.09	$\gamma$ -terpinene	99-85-4	1.59	767	4	1246/1290	44	Gal [2], K [6]
11	18.43	5.33	terpinolene	586-62-9	3.09	865	1	1283/1331	48	Gal [2], K[1]

**Table 4** Volatile compound profiles with literature/experimental retention indices of <sup>1</sup>I, <sup>2</sup>I and MS match scores of the green curry paste sample analyzed by CH/C 2DGC-MS. (Continued)

No.	t <sub>observed</sub> (min)	<sup>2</sup> t <sub>R</sub> (min)	Compound	CAS number	%PA	MS match	$\Delta^1 I$	$^2 I_{lit}^2 I_{exp}^b$	$\Delta^2 I$	found ingredient
26	28.34	7.24	neryl propionate	105-91-9	0.77	766	-18	1784/1760	24	Gre [4]
27	28.41	5.71	$\alpha$ -farnesene	502-61-4	0.83	826	6	1746/1694	52	L[2]
28	28.75	5.25	germacrene B	15423-57-1	0.15	689	-2	1819/1811	8	Gre [4]
29	28.84	5.94	$\beta$ -bisabolene	495-61-4	0.69	707	16	1728/1725	3	K[1]
30	29.72	6.62	trans- $\alpha$ -bisabolene	70286-32-7	0.48	673	23	1741/1794	53	K[1]
31	30.45	6.90	$\beta$ -sesquiphellandrene	20307-83-9	0.57	679	31	1772/1712	60	Gal [2]
32	35.89	11.79	carotol	465-28-1	0.33	682	-9	2026/2075	49	Gal [2]
33	35.91	12.61	ledol	577-27-5	3.07	778	20	2035/2085	50	L[2]
34	37.25	13.15	globulol	51371-47-2	0.48	822	5	2087/2147	60	L [2]
35	37.47	12.37	tumerone	180315-67-7	14.90	717	15	2245/2292	47	Gal [2]
36	15.00	4.10	1-propenyl benzene	637-50-3	0.32	821	13	NA		
37	16.87	3.17	2,4,6-trimethyldecane	62108-27-4	1.05	712	-7	NA		
38	17.64	7.34	$\beta$ -thujene	28634-89-1	0.38	877	3	NA		
39	31.35	8.85	cumyl alcohol	536-60-7	0.33	680	-7	NA		
40	32.92	9.02	cetene	629-73-2	0.37	725	-17	NA		
41	36.83	12.53	spirojatamol	128487-46-7	0.16	761	4	NA		
42	37.07	11.73	ar-turmerone	532-65-0	0.11	687	-15	NA		

#### 4.2 Tentative identification of compounds in green curry paste extract

According to the criteria of MS match score > 650,  $^1I$  and  $^2I$  differences of within  $\pm 40$  and 60 units as shown in Table 4.2, 36 tentative compounds were found in the first part with the ten dominant compounds of tumerone (14.90%),  $\beta$ -cubebene (8.77%),  $\alpha$ -ocimene (8.05%), terpinen-4-ol (5.30%), sabinene (3.21%), terpinolene (3.09%), ledol (3.07%),  $\alpha$ -pinene (1.66%),  $\gamma$ -terpinene (1.59%) and  $\beta$ -phellandrene (1.51%), respectively. These ten compounds were reported to contain in the following ingredients: tumerone (smell of herbal), terpinen-4-ol (smell of woody), from galangal [34],  $\beta$ -cubebene (smell of citrus) and sabinene (smell of minty) from green chili [4],  $\gamma$ -terpinene (smell of fresh),  $\beta$ -phellandrene from kaffir leave [1],  $\alpha$ -ocimene (smell of fruity) ledol (no smell) from lemongrass [2],  $\alpha$ -pinene (smell of citrus) from galangal [34] and green chili [4] and terpinolene (smell of sweet citrus) from galangal [2] and kaffir leave [1].

The tentative 36<sup>th</sup> to 42<sup>nd</sup> compounds as shown in Table 4.2 were confirmed by MS matching and  $^1I$  but not  $^2I$  that their literature  $^2I$  values are not applicable: 1-propenylbenzene (0.47%), 2,4,6-trimethyldecane (1.56%),  $\beta$ -thujene (0.38%), 4-isopropylbenzyl alcohol (0.33%), cetene (0.55%), spirojatamol (0.24%) aR-tumerone (0.16%). Both 4-isopropylbenzyl alcohol (smell of herbal) and aR-tumerone (smell of herbal) was found in galangal [35] and 2-thujene (smell of herbal) was found in kaffir leave [1].

Total peak capacity ( $n_{c,total}$ ) is calculated based on the total number of peaks with the average peak width at baseline of  $w_{b,ave}$  which fully occupy (baseline separation) a  $^2D$  separation space between the first and the latest eluting peaks with the retention times of  $t_{R,first}$  and  $t_{R,last}$ , respectively. This is according to the relationships of 1)  $n_{c,total} = {}^1n_c \times {}^2n_c$ , 2)  ${}^1n_c = ({}^1t_{R,first} - {}^1t_{R,last}) / {}^1w_{b,ave}$  and 3)  ${}^2n_c = \text{Period between each H/C} / {}^2w_{b,ave}$ . The superscripts 1 and 2 indicate that the parameters are in  ${}^1D$  or  ${}^2D$  separation, respectively. The period between each H/C of 5 min was applied in this study. The CH/C 2DGC analysis showed  $n_{c,total}$  of 5,840. This corresponds to 245 identified compounds, while these correspond to 87 compounds

identified according to the comparison with both the MS spectra and <sup>1</sup>/ library in Table 4.1.



## CHAPTER V

### CONCLUSION

In this work, the CH/C MDGC was applied to improve identification of volatile compounds in green curry paste using a CH/C MDGCMS approach. Volatile compounds of green curry paste were separated by CH/C MDGCMS using HP-5MS (30 m length x 250  $\mu\text{m}$  i.d. x 0.25  $\mu\text{m}$  thickness) and DB-WAX (60 m length x 250  $\mu\text{m}$  i.d. x 0.5  $\mu\text{m}$  thickness) for first non-polar and second polar columns, respectively. These two columns are connected by deans switch for H/C events. The data analysis result for identification of each volatile compounds is performed according to MS matching  $>650$ ,  $^1I$  and  $^2I$  library matches.

A Tentative 87 compound were confirmed by MS matching  $>650$  and  $^1I$  only and the 36 tentative compounds confirming by MS matching  $>650$ ,  $^1I$  and  $^2I$  library matches were found the ten dominant compounds of tumerone (14.90%),  $\beta$ -cubebene (8.77%),  $\alpha$ -ocimene (8.05%), terpinen-4-ol (5.30%), sabinene (3.21%), terpinolene (3.09%), ledol (3.07%),  $\alpha$ -pinene (1.66%),  $\gamma$ -terpinene (1.59%) and  $\beta$ -phellandrene (1.51%), respectively. In addition the tentative 7 compounds were confirmed by MS match score and  $^1I$  but not  $^2I$  that their literature  $^2I$  values are not applicable: 1-propenylbenzene (0.47%), 2,4,6-trimethyldecane (1.56%),  $\beta$ -thujene (0.38%), 4-isopropylbenzyl alcohol (0.33%), cetene (0.55%), spirojatamol (0.24%) aR-tumerone (0.16%).

The benefit of this work is to gain analytical approach of CH/C MDGCMS for identification of volatile compounds in green curry paste using confident confirmation of MS matching  $>650$  and both  $^1I$  on non-polar column and  $^2I$  on polar column. The applied system is expected to be useful for high confidence untargeted analysis of other food samples, and the data analysis approach could be applicable with any comprehensive MDGC operation in the future.





Appendix 1 the parameter of curve fitting for the isovolatility curves of *n*-alkanes.

p1	p2	p3	p4	p5
-0.003705351	-0.435281543	-0.672967911	7.82660444	4.6881819
C7 ( <sup>1</sup> t <sub>R</sub> experimental (min))	Experimental <sup>2</sup> t <sub>R</sub>	Calculated <sup>2</sup> t <sub>R</sub>	Difference <sup>2</sup> (min <sup>2</sup> )	
5.482	2.52	2.884	0.132755	
0	1.67	3.814	4.598697	

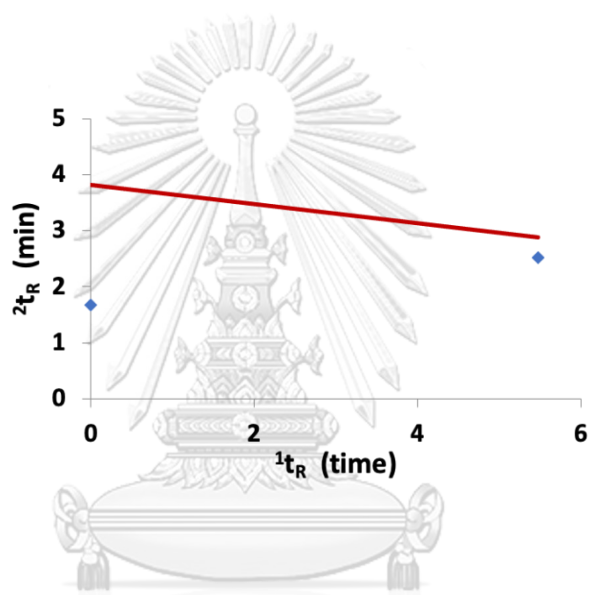

จุฬาลงกรณ์มหาวิทยาลัย  
CHULALONGKORN UNIVERSITY

p1	p2	p3	p4	p5
-0.003705351	-0.435281543	-0.672967911	7.82660444	-4.6881819
C8 ( <sup>1</sup> t <sub>R</sub> experimental (min))	Experimental <sup>2</sup> t <sub>R</sub>	Calculated <sup>2</sup> t <sub>R</sub>	difference <sup>2</sup> (min <sup>2</sup> )	
7.386	2.727	3.049	0.103722	
2.394	2.86	3.277	0.173507	

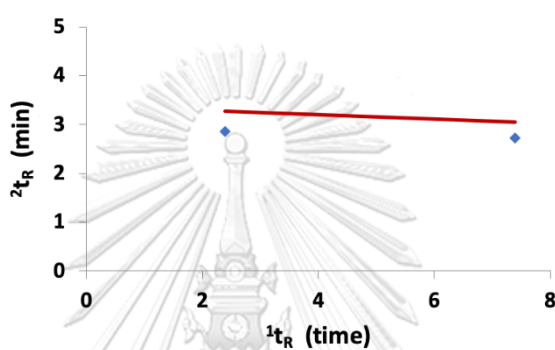

p1	p2	p3	p4	p5
-0.003705351	-0.435281543	-0.672967911	7.82660444	-4.6881819
C9 ( <sup>1</sup> t <sub>R</sub> experimental (min))	Experimental <sup>2</sup> t <sub>R</sub>	Calculated <sup>2</sup> t <sub>R</sub>	difference <sup>2</sup> (min <sup>2</sup> )	
9.911	2.92	3.160	0.057464	
6.718	3.058	3.338	0.078434	
4.823	3.307	3.480	0.030028	
1.874	4.037	3.780	0.066187	

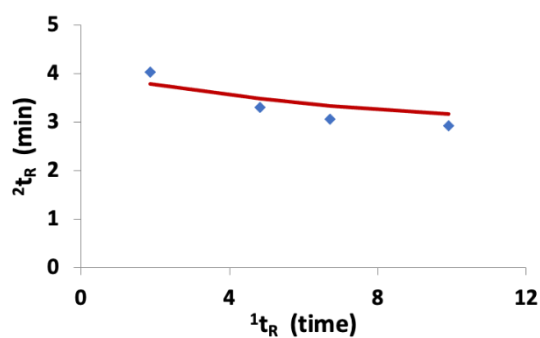

p1	p2	p3	p4	p5
-0.003705351	-0.435281543	-0.672967911	7.82660444	-4.6881819
C10 ( <sup>1</sup> t <sub>R</sub> experimental (min))	Experimental <sup>2</sup> t <sub>R</sub>	Calculated <sup>2</sup> t <sub>R</sub>	difference <sup>2</sup> (min <sup>2</sup> )	
12.726	3.083	3.259	0.031063	
10.899	3.179	3.377	0.039061	
9.585	3.321	3.478	0.024763	
7.677	3.665	3.659	4.01764E-05	
4.863	4.329	4.019	0.0959997	

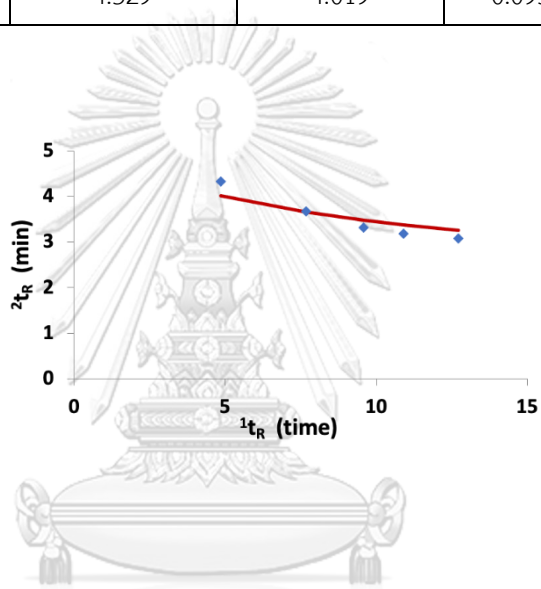

จุฬาลงกรณ์มหาวิทยาลัย  
CHULALONGKORN UNIVERSITY

p1	p2	p3	p4	p5
-0.003705351	-0.435281543	-0.672967911	7.82660444	-4.6881819
C11 ( <sup>1</sup> t <sub>R</sub> experimental (min))	Experimental <sup>2</sup> t <sub>R</sub>	Calculated <sup>2</sup> t <sub>R</sub>	difference <sup>2</sup> (min <sup>2</sup> )	
15.568	3.22	3.35	0.016890073	
14.584	3.285	3.421	0.018563064	
13.71	3.366	3.492	0.015894958	
12.363	3.558	3.617	0.003519588	
10.945	3.87	3.83	0.001569645	
7.734	4.565	4.258	0.094093993	

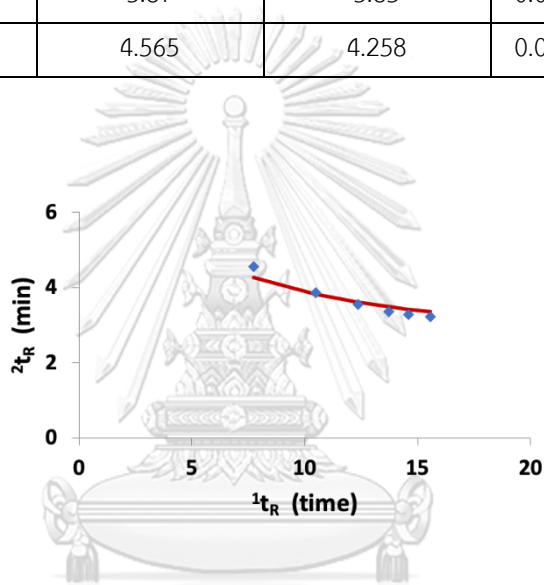

p1	p2	p3	p4	p5
-0.003705351	-0.435281543	-0.672967911	7.82660444	-4.6881819
C12 ( <sup>1</sup> t <sub>R</sub> experimental (min))	Experimental <sup>2</sup> t <sub>R</sub>	Calculated <sup>2</sup> t <sub>R</sub>	difference <sup>2</sup> (min <sup>2</sup> )	
18.319	3.339	3.435	0.009241	
17.805	3.38	3.477	0.009363	
17.248	3.425	3.525	0.00987	
16.313	3.541	3.614	0.005282	
14.935	3.734	3.765	0.000968	
13.023	4.082	4.025	0.003199	
10.282	4.813	4.537	0.07602	

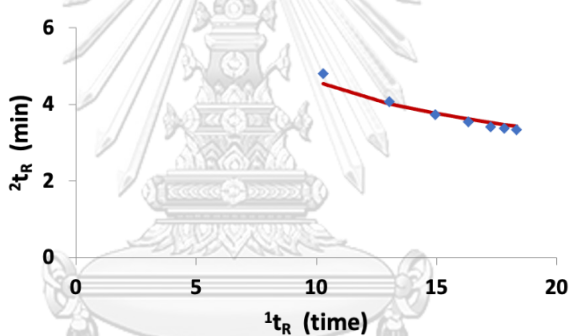

จุฬาลงกรณ์มหาวิทยาลัย  
CHULALONGKORN UNIVERSITY

p1	p2	p3	p4	p5
-0.003705351	-0.435281543	-0.672967911	7.82660444	-4.6881819
C13 ( <sup>1</sup> t <sub>R</sub> experimental (min))	Experimental <sup>2</sup> t <sub>R</sub>	Calculated <sup>2</sup> t <sub>R</sub>	difference <sup>2</sup> (min <sup>2</sup> )	
20.936	3.442	3.517	0.005645	
20.668	3.47	3.541	0.005077	
20.336	3.494	3.572	0.005818	
19.699	3.571	3.636	0.004163	
18.692	3.694	3.747	0.002758	
17.231	3.912	3.935	0.000552	
15.254	4.305	4.257	0.002758	
12.393	5.167	4.909	0.066344	
6.324	8.4	7.664	0.541141	

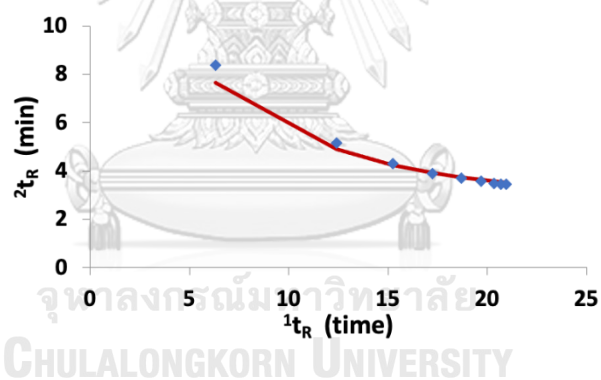

p1	p2	p3	p4	p5
-0.003705351	-0.435281543	-0.672967911	7.82660444	-4.6881819
C14 ( <sup>1</sup> t <sub>R</sub> experimental (min))	Experimental <sup>2</sup> t <sub>R</sub>	Calculated <sup>2</sup> t <sub>R</sub>	difference <sup>2</sup> (min <sup>2</sup> )	
23.418	3.535	3.597	0.003798	
23.279	3.562	3.61	0.002346	
23.088	3.562	3.63	0.004596	
22.678	3.603	3.673	0.004896	
21.948	3.71	3.756	0.002084	
20.837	3.849	3.897	0.002346	
19.265	4.111	4.137	0.000682	
17.154	4.592	4.551	0.001666	
14.172	5.567	5.394	0.030046	

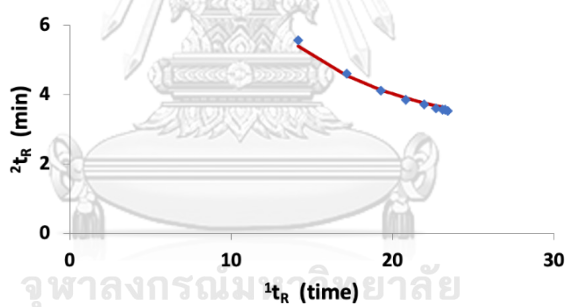



p1	p2	p3	p4	p5
-0.003705351	-0.435281543	-0.672967911	7.82660444	- 4.688181 9
C15 ( <sup>1</sup> t <sub>R</sub> experimental (min))	Experimental <sup>2</sup> t <sub>R</sub>	Calculated <sup>2</sup> t <sub>R</sub>	difference <sup>2</sup> (min <sup>2</sup> )	
25.763	3.611	3.675	0.004089404	
25.691	3.634	3.683	0.002379782	
25.578	3.644	3.695	0.00262397	
25.324	3.669	3.724	0.003009084	
24.821	3.726	3.783	0.003292859	
23.983	3.831	3.892	0.003672384	
22.732	4.011	4.077	0.004369727	
21.023	4.344	4.387	0.00183658	
18.765	4.914	4.927	0.000181107	

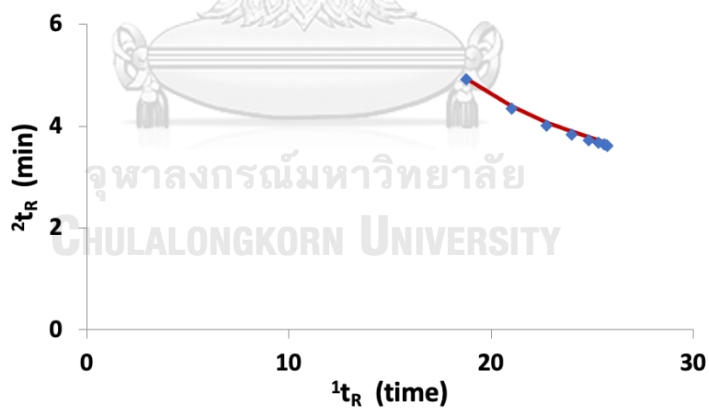

p1	p2	p3	p4	p5
-0.003705351	-0.435281543	-0.672967911	7.82660444	- 4.6881819
C16 ( <sup>1</sup> t <sub>R</sub> experimental (min))	Experimental <sup>2</sup> t <sub>R</sub>	Calculated <sup>2</sup> t <sub>R</sub>	difference <sup>2</sup> (min <sup>2</sup> )	
27.989	3.686	3.752	0.004294774	
27.951	3.705	3.756	0.002604465	
27.885	3.71	3.764	0.002905352	
27.732	3.724	3.782	0.003410457	
27.398	3.763	3.824	0.003730312	
26.788	3.836	3.905	0.004766526	
25.804	3.974	4.050	0.005805096	
24.398	4.212	4.294	0.006712173	
22.544	4.598	4.697	0.009785654	
17.068	6.572	6.780	0.043263497	

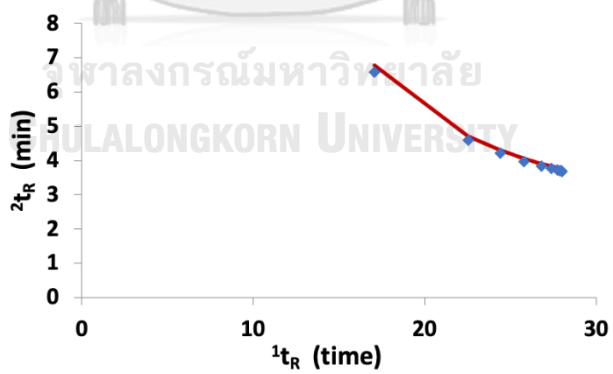

p1	p2	p3	p4	p5
-0.003705351	-0.435281543	-0.672967911	7.82660444	-4.6881819
C17 ( <sup>1</sup> t <sub>R</sub> experimental (min))	Experimental <sup>2</sup> t <sub>R</sub>	Calculated <sup>2</sup> t <sub>R</sub>	difference <sup>2</sup> (min <sup>2</sup> )	
30.113	3.771	3.826	0.002980529	
30.092	3.768	3.828	0.003633644	
30.058	3.775	3.833	0.003322746	
29.966	3.784	3.845	0.003666056	
29.737	3.808	3.875	0.004463472	
29.309	3.858	3.934	0.00575551	
28.56	3.952	4.046	0.008764559	
27.418	4.135	4.239	0.010856956	
25.856	4.424	4.558	0.01802305	
21.735	5.576	5.840	0.069485348	

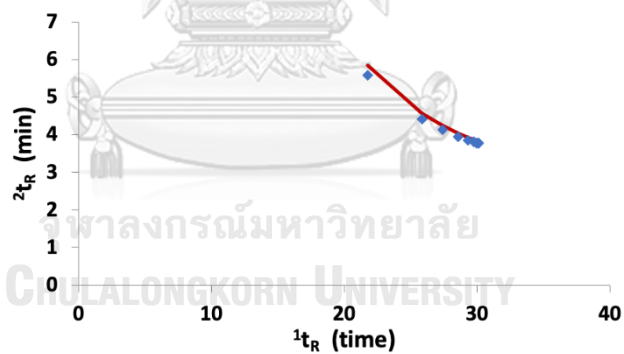

p1	p2	p3	p4	p5
-0.003705351	-0.435281543	-0.672967911	7.82660444	-4.6881819
C18 ( <sup>1</sup> t <sub>R</sub> experimental (min))	Experimental <sup>2</sup> t <sub>R</sub>	Calculated <sup>2</sup> t <sub>R</sub>	difference <sup>2</sup> (min <sup>2</sup> )	
32.127	3.908	3.899	7.43647E-05	
32.114	3.913	3.901	0.000140097	
32.1	3.916	3.903	0.00016662	
32.04	3.915	3.911	1.29911E-05	
31.9	3.926	3.931	2.52866E-05	
31.598	3.948	3.975	0.000709563	
31.047	3.996	4.059	0.003951499	
30.133	4.107	4.213	0.011257115	
28.816	4.307	4.472	0.027287212	
25.453	5.107	5.402	0.086869312	
19.947	7.452	8.441	0.977555825	

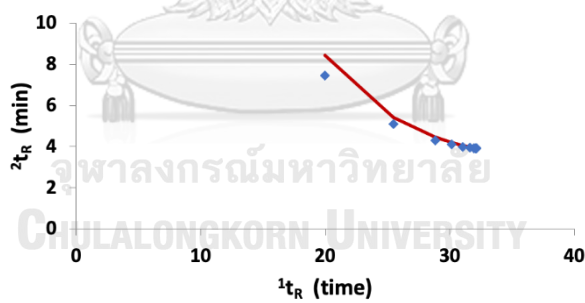

p1	p2	p3	p4	p5
-0.003705351	-0.435281543	-0.672967911	7.82660444	-4.6881819
C19 ( <sup>1</sup> t <sub>R</sub> experimental (min))	Experimental <sup>2</sup> t <sub>R</sub>	Calculated <sup>2</sup> t <sub>R</sub>	difference <sup>2</sup> (min <sup>2</sup> )	
34.094	4.214	4.082	0.017377654	
34.083	4.221	4.082	0.019272194	
34.078	4.221	4.082	0.019272194	
34.05	4.215	4.082	0.017642302	
33.948	4.222	4.082	0.019550843	
33.735	4.223	4.082	0.019831492	
33.32	4.223	4.084	0.019228407	
32.592	4.259	4.208	0.002575195	
31.503	4.351	4.418	0.004523076	
28.718	4.818	5.128	0.095848484	
24.992	6.022	6.673	0.423226352	

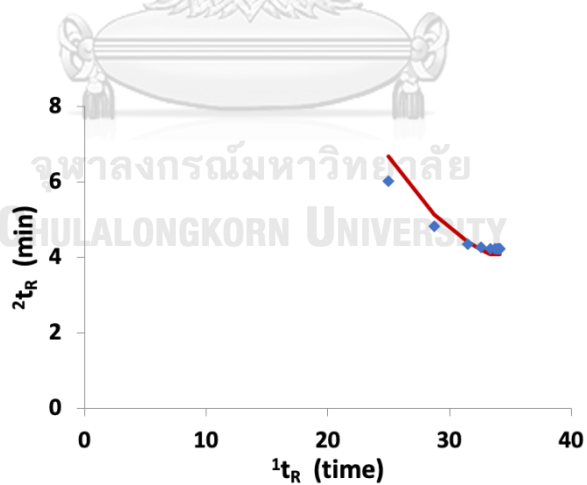

p1	p2	p3	p4	p5
-0.003705351	-0.435281543	-0.672967911	7.82660444	-4.6881819
C20 ( <sup>1</sup> t <sub>R</sub> experimental (min))	Experimental <sup>2</sup> t <sub>R</sub>	Calculated <sup>2</sup> t <sub>R</sub>	difference <sup>2</sup> (min <sup>2</sup> )	
36.168	4.69	4.521	0.028670459	
36.157	4.695	4.521	0.030388694	
36.158	4.695	4.521	0.030388694	
36.146	4.694	4.521	0.030041047	
36.07	4.694	4.521	0.030041047	
35.913	4.698	4.521	0.031443635	
35.577	4.691	4.521	0.029010106	
34.975	4.7	4.521	0.032156929	
33.995	4.701	4.521	0.032516576	
31.652	4.827	4.942	0.013304031	
28.858	5.393	5.919	0.276170036	
24.729	7.069	8.405	1.785456131	

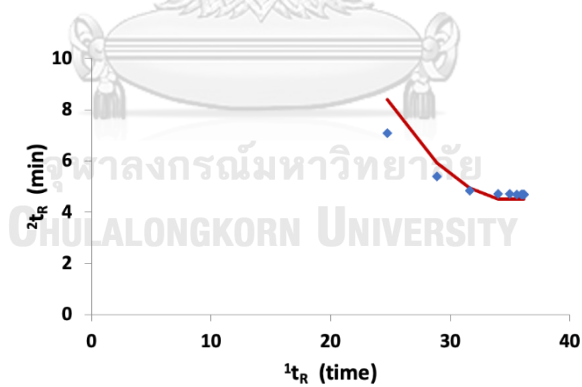

## Appendix 2 Repeat injection runs A) Run 4

Run4							
Retention time (min)	Area						
	R1	R2	R3	R4	R5	Average	%RSD
11.03	$2.90 \times 10^8$	$3.10 \times 10^8$	$2.98 \times 10^8$	$2.94 \times 10^8$	$2.90 \times 10^8$	$2.97 \times 10^8$	2.5
15.01	$2.79 \times 10^7$	$2.92 \times 10^7$	$2.97 \times 10^7$	$3.00 \times 10^7$	$2.77 \times 10^7$	$2.89 \times 10^7$	3.3
24.68	$1.25 \times 10^8$	$1.18 \times 10^8$	$1.22 \times 10^8$	$1.26 \times 10^8$	$1.17 \times 10^8$	$1.22 \times 10^8$	3.0
28.63	$5.45 \times 10^8$	$5.46 \times 10^8$	$5.64 \times 10^8$	$5.39 \times 10^8$	$5.26 \times 10^8$	$5.44 \times 10^8$	2.3
36.19	$7.41 \times 10^7$	$7.47 \times 10^7$	$7.44 \times 10^7$	$7.01 \times 10^7$	$7.47 \times 10^7$	$7.36 \times 10^7$	2.4

N	Retention time (min)	Repeating number													
		1		2		3		4		5		Average		%RSD	
		<sup>1</sup> / <sub>1</sub>	<sup>2</sup> / <sub>1</sub>	<sup>1</sup> / <sub>2</sub>	<sup>2</sup> / <sub>2</sub>	<sup>1</sup> / <sub>3</sub>	<sup>2</sup> / <sub>3</sub>	<sup>1</sup> / <sub>4</sub>	<sup>2</sup> / <sub>4</sub>	<sup>1</sup> / <sub>5</sub>	<sup>2</sup> / <sub>5</sub>	<sup>1</sup> / <sub>A</sub>	<sup>2</sup> / <sub>A</sub>	<sup>1</sup> / <sub>RSD</sub>	<sup>2</sup> / <sub>RSD</sub>
1	11.03	890	1333	890	1333	890	1333	890	1333	890	1333	890	1333	0.11	0.07
2	15.01	1106	1484	1106	1484	1106	1484	1106	1484	1106	1484	1106	1484	0.09	0.07
3	24.68	1326	1666	1326	1666	1326	1666	1326	1666	1326	1666	1326	1666	0.07	0.08
4	28.63	1555	1853	1555	1853	1555	1853	1555	1853	1555	1853	1555	1853	0.06	0.05
5	36.19	2152	2326	2152	2326	2152	2326	2152	2326	2152	2326	2152	2326	0.05	0.04

## B) Run 11

Run11							
Retention time (min)	Area						
	R1	R2	R3	R4	R5	Average	%RSD
15.01	$3.46 \times 10^7$	$3.33 \times 10^7$	$3.42 \times 10^7$	$3.36 \times 10^7$	$3.49 \times 10^7$	$0.34 \times 10^7$	2.6
24.70	$1.35 \times 10^8$	$1.36 \times 10^8$	$1.35 \times 10^8$	$1.31 \times 10^8$	$1.35 \times 10^8$	$1.35 \times 10^8$	1.3

N	Reten tion time (min)	Repeating number													
		1		2		3		4		5		Average		%RSD	
		<sup>1</sup> / <sub>1</sub>	<sup>2</sup> / <sub>1</sub>	<sup>1</sup> / <sub>1</sub>	<sup>2</sup> / <sub>1</sub>	<sup>1</sup> / <sub>1</sub>	<sup>2</sup> / <sub>1</sub>	<sup>1</sup> / <sub>1</sub>	<sup>2</sup> / <sub>1</sub>	<sup>1</sup> / <sub>1</sub>	<sup>2</sup> / <sub>1</sub>	<sup>1</sup> / <sub>1</sub>	<sup>2</sup> / <sub>1</sub>	<sup>1</sup> / <sub>1</sub>	<sup>2</sup> / <sub>1</sub>
1	15.01	1006	1063	1006	1063	1006	1063	1006	1063	1006	1063	1006	1063	0.10	0.09
2	24.70	1389	1454	1389	1454	1389	1454	1389	1454	1389	1454	1389	1454	0.07	0.07

%RSD is evaluated from SD of 1 for all <sup>2</sup>/<sub>1</sub>

### Appendix 3 the volatile compound profiles using 1DGC-MS

Peak Number	RI NIST14	CAS Number	Compound names
1	974	3387-41-5	sabinen
2	1028	99-84-3	$\beta$ -terpinen
3	991	123-35-3	$\beta$ -myrcene
4	986	110-93-0	sulcatone
5	1023	586-62-9	4-methyl-3-(1-methylethylidene)cyclohexene
6	1023	535-77-3	<i>m</i> -cymol
7	1030	138-86-3	limonene
8	1060	99-85-4	$\gamma$ -terpinene
9	1074	60047-17-8	linalyl oxide
10	1086	34995-77-2	trans-linalool oxide (furanoid)
11	1099	78-70-6	linalool
12	1122	29803-82-5	cis-2-menthenol



Peak Number	RI NIST14	CAS Number	Compound names
13	1140	29803-81-4	trans-2-menthenol
14	1153	565-48-0	$\beta$ -terpinol
15	1163	59905-53-2	dl-isopulegol
16	1177	562-74-3	terpinen-4-ol
17	1189	98-55-5	$\alpha$ -terpineol
18	1239	122-03-2	cumal
19	1297	2050-87-5	allyl trisulfide
20	1343	57709-95-2	2-oxabicyclo[2.2.2]octan-5-ol, 1,3,3-trimethyl-, acetate, (1 $\alpha$ ,4 $\alpha$ ,5 $\beta$ )-
21	1376	3856-25-5	copaene
22	1435	13474-59-4	trans- $\alpha$ -bergamotene
23	1419	87-44-5	caryophyllene
24	1435	17699-05-7	$\alpha$ -bergamotene
25	1433	29873-99-2	$\gamma$ -elemene
26	1453	6831-16-9	-(-)-aristolene
27	1491	26560-14-5	$\alpha$ -(Z,E)-farnesene
28	1457	18794-84-8	(E)- $\beta$ -farnesene
29	1454	6753-98-6	humulene
30	1485	483-75-0	naphthalene, 1,2,4a,5,6,8a-hexahydro-4,7-dimethyl-1-(1-methylethyl)-
31	1475	28477-64-7	( $\pm$ )- $\beta$ -acoradiene
32	1492	37-46-30	valencen
33	1509	495-62-5	$\beta$ -bisabolene
34	1513	1460-97-5	$\gamma$ -cadinene
35	1524	483-76-1	$\delta$ -cadinene
36	1508	502-61-4	$\alpha$ -farnesene
37	1631	1209-71-8	$\gamma$ -eudesmol
38	1645	36564-42-8	$\delta$ -cadinol
39	1664	532-65-0	aR-turmerone

Peak Number	RI NIST14	CAS Number	Compound names
40	1712	108645-54-1	(E)- $\gamma$ -atlantone
41	1744	72445-42-2	mintsulfide

Noted the data of volatile compounds with 1DGCMS from our research group.





จุฬาลงกรณ์มหาวิทยาลัย  
**CHULALONGKORN UNIVERSITY**

## REFERENCES

- [1] Yusoff, Z.M., Muhammad, Z., Kasuan, N., Hezri, M., Rahiman, F. , and Taib, M.N.b. (2013). EFFECT OF TEMPERATURE ON KAFFIR LIME OIL BY USING HYDRO- DIFFUSION STEAM DISTILLATION SYSTEM (Kesan Suhu Ke Atas Minyak Limau Purut Dengan Menggunakan Sistem Penyulingan Penyebaran Hidro).
- [2] Boukhatem, M.N., Ferhat, M.A., Kameli, A., Saidi, F. , and Kebir, H.T. Lemon grass (*Cymbopogon citratus*) essential oil as a potent anti-inflammatory and antifungal drugs. Libyan Journal of Medicine 9 (1) 2014:25431.
- [3] Molina-Calle, M., Priego-Capote, F. , and Luque de Castro, M.D. Headspace–GC–MS volatile profile of black garlic vs fresh garlic: Evolution along fermentation and behavior under heating. LWT 80 2017:98-105.
- [4] Junior, S., et al. Analysis of Volatile Compounds in Capsicum Spp. by Headspace Solid-Phase Microextraction and GCxGC-TOFMS. Analytical Methods 7 2014:
- [5] Bogusz Junior, S., et al. Analysis of volatile compounds in Capsicum spp. by headspace solid-phase microextraction and GC x GC-TOFMS. Analytical Methods 7 (2) 2015:521-529.
- [6] (2013). Supercritical Fluid Extraction and Gas Chromatographic-Mass Spectrometric Analysis of Terpenoids in Fresh Kaffir Lime Leaf Oil.
- [7] Harynuk, J. and Górecki, T. Flow model for coupled-column gas chromatography systems. Journal of Chromatography A 1086 (1) 2005:135-140.
- [8] Kulsing, C., Nolvachai, Y. , and Marriott, P.J. Concepts, selectivity options and experimental design approaches in multidimensional and comprehensive two-dimensional gas chromatography. TrAC Trends in Analytical Chemistry 130 2020:115995.
- [9] Nolvachai, Y., Kulsing, C. , and Marriott, P.J. Multidimensional gas chromatography in food analysis. TrAC - Trends in Analytical Chemistry 96 2017:124–137.
- [10] Tranchida, P.Q., Donato, P., Cacciola, F., Beccaria, M., Dugo, P. , and Mondello, L. Potential of comprehensive chromatography in food analysis. TrAC - Trends in Analytical Chemistry 52 2013:186–205.
- [11] Prebihalo, S.E., et al. Multidimensional Gas Chromatography: Advances in

Instrumentation, Chemometrics, and Applications. Anal. Chem. 90 (1) 2018:505–532.

[12] Kulsing, C., Nolvachai, Y., Rawson, P., Evans, D.J. , and Marriott, P.J. Continuum in MDGC Technology: From Classical Multidimensional to Comprehensive Two-Dimensional Gas Chromatography. Analytical Chemistry 88 (7) 2016:3529-3538.

[13] Nolvachai, Y., Kulsing, C. , and Marriott, P.J. In Silico Modeling of Hundred Thousand Experiments for Effective Selection of Ionic Liquid Phase Combinations in Comprehensive Two-Dimensional Gas Chromatography. Analytical Chemistry 88 (4) 2016:2125-2131.

[14] Tian, P., et al. Analysis of volatile compound changes in fried shallot (*Allium cepa* L. var. *aggregatum*) oil at different frying temperatures by GC–MS, OAV, and multivariate analysis. Food Chemistry 345 2021:128748.

[15] Rana, V.S., Verdeguer, M. , and Blazquez, M.A. GC and GC/MS Analysis of the Volatile Constituents of the Oils of *Alpinia galanga* (L.) Willd and *A. officinarum* Hance Rhizomes. Journal of Essential Oil Research 22 (6) 2010:521-524.

[16] Jirapakkul, W., Tinchan, P. , and Chaiseri, S. Effect of drying temperature on key odourants in kaffir lime (*Citrus hystrix* D.C., Rutaceae) leaves. International Journal of Food Science and Technology 48 (1) 2013:143-149.

[17] Rauniyar, N., Stevens, S.M. , and Prokai, L. Fourier transform ion cyclotron resonance mass spectrometry of covalent adducts of proteins and 4-hydroxy-2-nonenal, a reactive end-product of lipid peroxidation. Analytical and Bioanalytical Chemistry 389 (5) 2007:1421-1428.

[18] French, D. Chapter Five - Advances in Clinical Mass Spectrometry. in Makowski, G.S. (ed.)^(eds.),Advances in Clinical Chemistry, p.^pp. 153-198. Elsevier, 2017.

[19] Chin, S.-T. and Marriott, P.J. Multidimensional gas chromatography beyond simple volatiles separation. Chemical Communications 50 (64) 2014:8819-8833.

[20] Marriott, P.J., Chin, S.-T., Maikhunthod, B., Schmarr, H.-G. , and Bieri, S. Multidimensional gas chromatography. TrAC Trends in Analytical Chemistry 34 2012:1-21.

[21] Khummueng, W., Harynuk, J. , and Marriott, P.J. Modulation ratio in comprehensive two-dimensional gas chromatography. Analytical Chemistry 78 (13)

2006:4578-4587.

- [22] Adahchour, M., Beens, J., Vreuls, R.J.J. , and Brinkman, U.A.T. Recent developments in comprehensive two-dimensional gas chromatography (GCxGC): II. Modulation and detection. TrAC Trends in Analytical Chemistry 25 (6) 2006:540-553.
- [23] Janta, P., et al. Strategies towards simpler configuration and higher peak capacity with comprehensive multidimensional gas chromatography. RSC Advances 11 (14) 2021:7946-7953.
- [24] Cai, H. and Stearns, S.D. A comprehensive two-dimensional gas chromatography valve modulation method using hold-release primary column flow for long secondary separation time with 100% transfer. Journal of Chromatography A 1569 2018:200-211.
- [25] Thongdorn, N., Nhujak, T., Janta, P., Rueangthaweeep, A., Hinchiranan, N. , and Kulsing, C. Cryogen-free comprehensive heartcut multidimensional gas chromatography using a Deans switch for improved analysis of petrochemical products derived from palmitic acid oxidation. Analytical Methods 12 (43) 2020:5160-5167.
- [26] Webster, R.e.L., Evans, D.J. , and Marriott, P.J. Detailed chemical analysis using multidimensional gas chromatography–mass spectrometry and bulk properties of low-temperature oxidized jet fuels. Energy & Fuels 29 (4) 2015:2059-2066.
- [27] Janta, P., et al. A multi-location peak parking approach for calculation of second dimensional retention indices for improved volatile compound identification with cryogen-free comprehensive heart-cut two-dimensional gas chromatography. Analytical Methods 13 (1) 2021:124-132.
- [28] Kakanopas, P., Janta, P., Vimolmangkang, S., Hermatasia, F. , and Kulsing, C. Retention index based approach for simulation of results and application for validation of compound identification in comprehensive two-dimensional gas chromatography. Journal of Chromatography A 1679 2022:463394.
- [29] Jiang, M., Kulsing, C., Nolvachai, Y. , and Marriott, P. Two-Dimensional Retention Indices Improve Component Identification in Comprehensive Two-Dimensional Gas Chromatography of Saffron. Analytical chemistry 87 2015:
- [30] Wang, B., et al. A regression model for calculating the second dimension retention index in comprehensive two-dimensional gas chromatography time-of-flight mass spectrometry. Journal of Chromatography A 1451 2016:127-134.

- [31] Nolvachai, Y., Kulsing, C. , and Marriott, P.J. Multidimensional Gas Chromatography in Food Analysis. TrAC Trends in Analytical Chemistry 96 2017:124-137.
- [32] Jiang, M., Kulsing, C., Nolvachai, Y. , and Marriott, P. Two-dimensional retention indices improve component identification in comprehensive two-dimensional gas chromatography of saffron. J Analytical chemistry 87 (11) 2015:5753-5761.
- [33] Janta, P., et al. A multi-location peak parking approach for calculation of second dimensional retention indices for improved volatile compound identification with cryogen-free comprehensive heart-cut two-dimensional gas chromatography. Analytical Methods 13 (1) 2021:124-132.
- [34] Xu, L.-l., et al. Analysis of curcuminoids and volatile components in 160 batches of turmeric samples in China by high-performance liquid chromatography and gas chromatography mass spectrometry. Journal of Pharmaceutical and Biomedical Analysis 188 2020:113465.
- [35] Xie, Z.-S., Xu, X.-J., Xie, C.-Y., Huang, J.-Y., Yang, M. , and Yang, D.-P. Volatile components of Rhizoma Alpiniae Officinarum using three different extraction methods combined with gas chromatography–mass spectrometry. Journal of pharmaceutical analysis 3 (3) 2013:215-220.

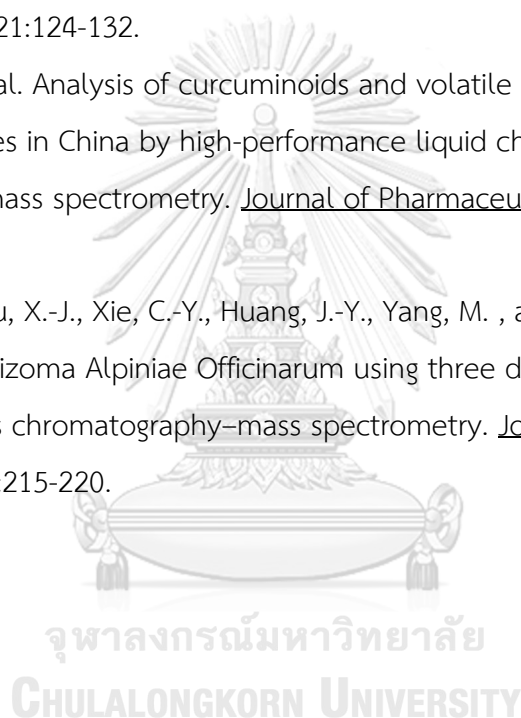



จุฬาลงกรณ์มหาวิทยาลัย  
**CHULALONGKORN UNIVERSITY**



## VITA

**NAME** Miss Sudarat Arunmongkon

**DATE OF BIRTH** 02 November 1994

**PLACE OF BIRTH** Bangkok

**INSTITUTIONS ATTENDED** B.Sc., King Mongkut's University of Technology Thonburi,  
THAILAND

**HOME ADDRESS** 19/215 Village No.5 Navamin Road, Klongkum Sub-district,  
Beungkum District, Bangkok, 10240

