

ผลของการผสมผลึกเหลวมวลโมเลกุลต่ำกับพอลิคาร์บอเนต
โดยใช้เครื่องมือชนิดต่าง ๆ ในกระบวนการขึ้นรูปพอลิเมอร์



นางสาว สุภลักษณ์ คุณประเสริฐ

สถาบันวิทยบริการ

วิทยานิพนธ์นี้เป็นส่วนหนึ่งของการศึกษาตามหลักสูตรปริญญาวิศวกรรมศาสตรมหาบัณฑิต

สาขาวิชาวิศวกรรมเคมี ภาควิชาวิศวกรรมเคมี

คณะวิศวกรรมศาสตร์ จุฬาลงกรณ์มหาวิทยาลัย

ปีการศึกษา 2545

ISBN 974-17-1779-2

ลิขสิทธิ์ของจุฬาลงกรณ์มหาวิทยาลัย

EFFECTS OF LOW MOLECULAR WEIGHT LIQUID CRYSTAL BLEND WITH
POLYCARBONATES USING VARIOUS POLYMER PROCESSING INSTRUMENTS



Miss Supaluk Khunprasert

สถาบันวิทยบริการ
จุฬาลงกรณ์มหาวิทยาลัย
A Thesis Submitted in Partial Fulfillment of the Requirements
for the Degree of Master of Engineering in Chemical Engineering

Department of Chemical Engineering

Faculty of Engineering

Chulalongkorn University

Academic Year 2002

ISBN 974-17-1779-2

Thesis Title EFFECTS OF LOW MOLECULAR WEIGHT LIQUID CRYSTAL BLEND WITH POLYCARBONATES USING VARIOUS POLYMER PROCESSING INSTRUMENTS

By Miss Supaluk Khunprasert

Field of study Chemical Engineering

Thesis Advisor Assistant Professor ML. Supakanok Thongyai , Ph.D.

Thesis Co-advisor Wannee Chinsirikul , Ph.D.

Accepted by the Faculty of Engineering, Chulalongkorn University in Partial Fulfillment of the Requirements for the Master's Degree

.....Dean of Faculty of Engineering
(Professor Somsak Panyakeow , D.Eng.)

THESIS COMMITTEE

.....Chairman
(Professor Piyasan Prasertdam , Dr.Ing.)

.....Thesis Advisor
(Assistant Professor ML. Supakanok Thongyai , Ph.D.)

.....Thesis Co-Advisor
(Wannee Chinsirikul , Ph.D.)

.....Member
(Assistant Professor Siriporn Damrongsakkul , Ph.D.)

.....Member
(Assistant Professor Seeroong Prichanont , Ph.D.)

สัญลักษณ์ คุณประเสริฐ : ผลของการผสมผลึกเหลวมวลโมเลกุลต่ำกับพอลิคาร์บอเนตโดยใช้เครื่องมือชนิดต่าง ๆ ในกระบวนการขึ้นรูปพอลิเมอร์ (Effects of Low Molecular Weight Liquid Crystal Blend with Polycarbonates Using Various Polymer Processing Instruments) อาจารย์ที่ปรึกษา : ผศ. ดร. มล. ศุภกนก ทองใหญ่, อาจารย์ที่ปรึกษาร่วม : ดร. วรณี จินศิริกุล, 112 หน้า. ISBN 974-17-1779-2.

งานวิจัยนี้สนใจศึกษาเกี่ยวกับผลของการผสมผลึกเหลวมวลโมเลกุลต่ำ (low molecular weight liquid crystal) กับพอลิคาร์บอเนตที่มีต่อสมบัติทางกล (mechanical property) สมบัติทางความร้อน (thermal property) โครงสร้าง (morphology) และการกระจายตัวของมวลโมเลกุล (molecular weight distribution) ของพอลิเมอร์ผสม โดยใช้พอลิคาร์บอเนต 2 ชนิดซึ่งมีมวลโมเลกุลแตกต่างกัน (PC2600 และ PC2405) ผสมกับผลึกเหลวมวลโมเลกุลต่ำ (CBC-33) ที่ความเข้มข้นประมาณ 0.2 เปอร์เซ็นต์โดยน้ำหนัก ในการผสมนี้ใช้เครื่องอินเทอร์นอลมิกเซอร์ (internal mixer) เครื่องอัดรีดแบบสกรูเดี่ยว (single screw extruder) และเครื่องอัดรีดแบบสกรูคู่ (twin screw extruder) จากการวิจัยพบว่าค่าแรงบิดที่วัดได้จากเครื่องมือชนิดต่าง ๆ เมื่อใช้ผสมพอลิเมอร์ผสมมีค่าต่ำกว่าค่าแรงบิดของเครื่องมืออื่น ๆ เมื่อใช้ผสมพอลิคาร์บอเนตบริสุทธิ์ เมื่อผสมผลึกเหลวมวลโมเลกุลต่ำประมาณ 0.2 เปอร์เซ็นต์โดยน้ำหนักโดยใช้เครื่องอินเทอร์นอลมิกเซอร์ ค่าแรงบิดมีค่าลดลงประมาณ 20 เปอร์เซ็นต์ เมื่อผสมโดยใช้เครื่องอัดรีดแบบสกรูเดี่ยว ค่าแรงบิดมีค่าลดลงประมาณ 83 เปอร์เซ็นต์ และเมื่อผสมโดยใช้เครื่องอัดรีดแบบสกรูคู่ค่าแรงบิดมีค่าลดลงประมาณ 51 เปอร์เซ็นต์ จากปรากฏการณ์ดังกล่าวทำให้ทราบว่าผลึกเหลวมวลโมเลกุลต่ำสามารถลดความเหนียวของพอลิคาร์บอเนตได้ ในขณะที่สมบัติทางกลของพอลิเมอร์ผสมมีค่าใกล้เคียงกับพอลิคาร์บอเนตบริสุทธิ์ โดยความแข็งแรงทางแรงดึง (tensile strength) และค่ามอดูลัส (modulus of elasticity) ของพอลิเมอร์ผสมกับพอลิคาร์บอเนตบริสุทธิ์มีค่าแตกต่างกันไม่เกิน 10 เปอร์เซ็นต์ การผสมผลึกเหลวมวลโมเลกุลต่ำส่งผลต่อลักษณะโครงสร้าง สมบัติทางความร้อนและการกระจายตัวของมวลโมเลกุลของพอลิเมอร์ผสมเพียงเล็กน้อย

สถาบันวิทยบริการ
จุฬาลงกรณ์มหาวิทยาลัย

ภาควิชา.....วิศวกรรมเคมี.....ลายมือชื่อผู้คิด.....
สาขาวิชา.....วิศวกรรมเคมี.....ลายมือชื่ออาจารย์ที่ปรึกษา.....
ปีการศึกษา.....2545.....ลายมือชื่ออาจารย์ที่ปรึกษาร่วม.....

4370576021 : MAJOR CHEMICAL ENGINEERING

KEY WORD: LOW MOLECULAR WEIGHT LIQUID CRYSTAL/ POLYCARBONATE/ POLYMER PROCESSING

SUPALUK KHUNPRASERT: EFFECTS OF LOW MOLECULAR WEIGHT LIQUID CRYSTAL BLEND WITH POLYCARBONATES USING VARIOUS POLYMER PROCESSING INSTRUMENTS. THESIS ADVISOR: ASSISTANT PROFESSOR ML. SUPAKANOK THONGYAI, Ph.D., THESIS CO-ADVISOR: WANNEE CHINSIRIKUL, Ph.D., 112 pp. ISBN 974-17-1779-2.

This research is concerned about the effects of low molecular weight liquid crystal (LCC) blend with polycarbonates that influence on the mechanical properties, thermal properties, morphology and molecular weight distributions of polymer blends. The two polycarbonates, having different weight average molecular weight (PC2600 and PC2405), were blended with LCC (CBC-33) at concentration about 0.2% by weight using an internal mixer, a single screw extruder and a twin screw extruder. The results showed that the operating torque of the internal mixer used when melting polycarbonate blended with LCC was reduced about 20%, the operating torque of the single screw extruder used when extruding polycarbonate blended with LCC was reduced about 83% and the operating torque of the twin screw extruder used when extruding polycarbonate blended with LCC was reduced about 51%. This phenomenon indicated that LCC could act as a viscosity modifier of polycarbonates. The mechanical properties were determined by tensile testing specimens from injection molding machine, the difference of tensile strengths and modulus of elasticities between pure polycarbonates and their blends were less than 10 percent for all mixing processes. The additions of small amount of LCC have slight effects on the morphology, thermal properties and molecular weight distributions of polycarbonates.

สถาบันวิทยบริการ
จุฬาลงกรณ์มหาวิทยาลัย

Department.....Chemical Engineering..... Student's signature.....
Field of study.....Chemical Engineering..... Advisor's signature.....
Academic year.....2000..... Co-advisor's signature.....

ACKNOWLEDGEMENT

I would like to express my deeply gratitude to my advisor, Assistant Professor Dr. ML. Supakanok Thongyai to his continuous guidance, enormous number of discussions, helpful suggestions, warm encouragement and patience to correct my writing. Another great person that I would like to gratitude is my Co-advisor, Dr. Wannee Chinsirikul to her guidance, useful discussions, helpful suggestions, kindness and patience to correct my writing. I am also grateful to Professor Dr. Piyasan Praserttham, Assistant Professor Dr. Siriporn Damrongsakkul and Assistant Professor Dr. Seerong Prichanont for serving as the chairman and the member of the thesis committees, respectively whose comments were constructively and especially helpful.

The financial support from National Metal and Materials Technology Center (MTEC) is gratefully acknowledge.

Sincere thanks are made to MTEC for their assistance about the internal mixer and single screw extruder, Department of Tool and Materials Engineering, King Mongkut's University of Technology Thonburi for their assistance about the twin screw extruder, Institute of Technological Development for Industry, King Mongkut's Institute of Technology North Bangkok for their assistance about the injection molding machine.

Also thanks to Bayer Polymer Company Limited for providing polycarbonates and Thai Petrochemical Industry Public Company Limited for providing polyethylene in this study.

Sincere thanks to all my friends and all members of the Polymer Engineering research laboratory for their assistance and friendship.

Finally I would like to dedicate this thesis to my parents and my families, who generous supported and encouraged me through the year spent on this study.

CONTENTS

	Page
Abstract (in Thai).....	iv
Abstract (in English).....	v
Acknowledgement.....	vi
Contents.....	vii
List of tables.....	xii
List of figures.....	xv
Chapter 1 Introduction.....	1
1.1 General Introduction.....	1
1.2 The Objectives of the Present Study.....	3
1.3 The Scope of the Present Study.....	4
Chapter 2 Literature Review.....	5
Chapter 3 Theory.....	11
3.1 Poly(bisphenol A carbonate), PC.....	11
3.1.1 Characteristics of Polycarbonate.....	11
3.1.2 Product Applications.....	12
3.2 High Density Polyethylene, HDPE.....	14
3.2.1 Characteristics of High Density Polyethylene.....	14
3.2.2 Product Applications.....	15
3.3 Liquid Crystal.....	17
3.3.1 The History of Liquid Crystal.....	17
3.3.2 Introduction to Liquid Crystal.....	18
3.3.3 Main-Chain Polymer Liquid Crystals.....	18
3.3.4 Side Chain Polymer Liquid Crystals.....	21
3.3.5 Type of Liquid Crystal.....	22
3.3.6 Liquid Crystal Phases.....	23
3.3.7 Mesophasic Transition Temperature.....	25
3.3.8 Applications of Liquid Crystals.....	26
3.3.9 Structural Considerations of Low Molecular Weight Liquid Crystal Systems.....	27

CONTENTS (continued)

	Page
3.4 Polymer Processing.....	30
3.4.1 Miniaturized Internal Mixer.....	31
3.4.2 Single Screw Extrusion.....	33
3.4.3 Twin Screw Extrusion.....	36
3.4.4 Injection Molding.....	37
Chapter 4 Experiments	
4.1 Materials.....	43
4.1.1 Poly (bisphenol A carbonate), PC.....	43
4.1.2 High Density Polyethylene, HDPE.....	44
4.1.3 Liquid Crystal.....	44
4.2 Equipments.....	46
4.2.1 Digital Hot Plate Stirrer.....	46
4.2.2 Hydraulic Hot Press.....	46
4.2.3 Internal Mixer.....	46
4.2.4 Single Screw Extruder.....	46
4.2.5 Twin Screw Extruder.....	47
4.2.6 Injection Molding Machine.....	47
4.2.7 Tensile Testing Machine.....	47
4.2.8 Differential Scanning Calorimetry (DSC).....	48
4.2.9 Gel Permeation Chromatography (GPC).....	48
4.2.10 Scanning Electron Microscopy (SEM).....	48
4.3 Searching for the Appropriate Methods of Mixing Polymer and Low Molecular Weight Liquid Crystal Using the Internal Mixer.....	51
4.3.1 Preparation of Master Batch (Concentration 10% by weight BCH-5).....	51
4.3.2 Method of Experiment.....	51
4.4 Using the Internal Mixing Machine Performances to Select the Appropriate Concentration of Low Molecular Weight Liquid Crystal and Rotors Speed.....	52
4.4.1 Preparation of Master Batch (Concentration 1.1, 2.2, 4.4, 8.8 % by weight BCH-5).....	52
4.4.2 Method of Experiment.....	52

CONTENTS (continued)

	Page
4.5 Searching for the Appropriate Operating Temperature of Polycarbonate Using the Internal Mixer.....	53
4.5.1 Method of Determining the Appropriate Operating Temperature	53
4.6 Approach to Remix Using the Internal Mixer.....	53
4.6.1 Preparation of Master Batch (Concentration 8.8% by weight CBC-33).....	53
4.6.2 Preparation of PC2600 remix and PC2405 remix.....	54
4.6.3 Method of Experiment.....	54
4.7 Methods of Experiments Using the Single Screw Extruder.....	55
4.7.1 Sample Preparation.....	55
4.7.2 Method of Determining the Appropriate Operating Temperature.....	55
4.7.3 Method of Determining the Appropriate Screw Speed.....	55
4.8 Effects of Added Low Molecular Weight Liquid Crystal Blend with Polycarbonate on the Operating Torque of the Single Screw Extruder	56
4.8.1 Preparation of Master Batch (Concentration 8% by weight CBC-33).....	56
4.8.2 Sample Preparation.....	56
4.8.3 Method of Experiment.....	56
4.9 Methods of Experiments Using the Twin Screw Extruder.....	57
4.9.1 Sample Preparation.....	57
4.9.2 Method of Determining the Appropriate Operating Temperature.....	57
4.9.3 Method of Determining the Appropriate Screw Speed.....	57
4.10 Effects of Added Low Molecular Weight Liquid Crystal Blend with Polycarbonate on the Operating Torque of the Twin Screw Extruder	58
4.10.1 Preparation of Master Batch (Concentration 8% by weight CBC-33).....	58
4.10.2 Sample Preparation.....	58
4.10.3 Method of Experiment.....	58
4.11 Methods of Experiments Using the Injection Molding Machine.....	59
4.11.1 Sample Preparation.....	59
4.11.2 Method of Experiment.....	59

CONTENTS (continued)

	Page
4.12 Effects of Various Low Molecular Weight Liquid Crystal Blends on the Operating Pressures of the Injection Molding Machine	60
4.12.1 Sample Preparation.....	60
4.12.2 Method of Experiment.....	60
4.13 Tensile Testing of Samples from the Injection Molding Machine.....	61
Chapter 5 Results and Discussions	
5.1 The Appropriate Methods of Mixing Polymer and Low Molecular Weight Liquid Crystal.....	62
5.2 The Appropriate Concentration of Low Molecular Weight Liquid Crystal Master Batch and Rotor Speed of the Internal Mixer.....	64
5.3 The Appropriate Operating Temperature for Polycarbonate in the Internal Mixer.....	67
5.4 Effects of Mixing Low Molecular Weight Liquid Crystal on the Operating Torque of the Internal Mixer.....	68
5.5 The Appropriate Operating Temperature and Screw Speed for Polycarbonate in the Single Screw Extruder.....	69
5.6 Effects of Mixing Low Molecular Weight Liquid Crystal on the Operating Torque of the Single Screw Extruder.....	70
5.7 The Appropriate Operating Temperature and Screw Speed for Polycarbonate in the Twin Screw Extruder.....	71
5.8 Effects of Mixing Low Molecular Weight Liquid Crystal on the Operating Torque of the Twin Screw Extruder.....	73
5.9 The Appropriate Operating Temperature for Polycarbonate in the Injection Molding Machine.....	74
5.10 Effects of Various Low Molecular Weight Liquid Crystal Blends on the Operating Pressures of the Injection Molding Machine.....	75
5.11 Mechanical Properties.....	75
5.11.1 Tensile Strength.....	75
5.11.2 Modulus of Elasticity.....	76
5.12 Thermal Properties.....	84
5.13 Molecular Weight and Molecular Weight Distribution.....	89

CONTENTS (continued)

	Page
5.14 Morphology.....	94
5.15 Comparison of the Torque of the Internal Mixer, Single Screw Extruder and Twin Screw Extruder Used when Melting the Polycarbonates.....	97
Chapter 6 Conclusions and Recommendations	
6.1 Conclusions.....	100
6.2 Recommendations for Further Studies.....	101
References.....	102
Appendix.....	104
Vita.....	112



สถาบันวิทยบริการ
จุฬาลงกรณ์มหาวิทยาลัย

LIST OF TABLES

		Page
Table 3-1	Properties of polycarbonate.....	13
Table 3-2	Properties of high density polyethylene	16
Table 4-1	Properties of CBC-33.....	45
Table 4-2	Properties of BCH-5.....	45
Table 4-3	Dimensions of tensile specimen.....	61
Table 5-1	The torque values of the internal mixer used when melting pure HDPE and HDPE blended with BCH-5	62
Table 5-2	The torque values of the internal mixer used when melting the blends at various concentrations of the master batch of BCH-5 and rotor speeds	64
Table 5-3	The temperature ranges of the internal mixer used when melting the blends at various concentrations of the master batch of BCH-5 and rotor speeds.....	64
Table 5-4	The torque values of the internal mixer used when melting pure PC2600 at various the operating temperatures at rotor speed of 40 rpm.....	67
Table 5-5	The torque values of the internal mixer used when melting pure PC2600, PC2405 and their blends with CBC-33.....	68
Table 5-6	The torque values of the single screw extruder used when extruding pure PC2600 at various operating temperature ranges at screw speed of 40 rpm.....	69
Table 5-7	The torque values of the single screw extruder used when extruding pure PC2600 at screw speeds of 20 and 40 rpm at the operating temperature of 260, 270, 280 °C for the three extruder zones and 280 °C for die	69
Table 5-8	The torque values of the single screw extruder used when extruding pure PC2600, pure PC2405 and their blends with CBC-33.....	70
Table 5-9	The torque values of the twin screw extruder used when extruding of pure PC2600 at various operating temperature ranges at screw speed of 40 rpm	71
Table 5-10	The torque values of the twin screw extruder used when extruding of pure PC2600 at screw speed of 40 and 60 rpm at operating temperature range of 240, 250, 260 °C for the three extruder zones and 260 °C for die	72
Table 5-11	The torque values of the twin screw extruder used when extruding pure PC2600, PC2405 and their blends with CBC-33.....	73
Table 5-12	The operating temperature ranges for pure PC2600 in the injection molding machine	74

LIST OF TABLES (continued)

		Page
Table 5-13	Tensile strengths of pure PC2600, PC2405 and their blends with CBC-33 by mixing in the internal mixer, single screw extruder and twin screw extruder	76
Table 5-14	Modulus of elasticity values of pure PC2600, PC2405 and their blends with CBC-33 by mixing in the internal mixer, single screw extruder and twin screw extruder.....	77
Table 5-15	Glass transition temperatures of PC2600 before and after blending with CBC-33 by the twin screw extruder.....	84
Table 5-16	Weight average molecular weight (M _w), number average molecular weight (M _n) and molecular weight distribution (MWD) of PC2600 and PC2405 before and after blending with CBC-33 by the internal mixer	89
Table B-1	Tensile strengths of PC2600 and its blends with CBC-33 prepared by the internal mixer.....	106
Table B-2	Tensile strengths of PC2405 and its blends with CBC-33 prepared by the internal mixer.....	106
Table B-3	Tensile strengths of PC2600 and its blends with CBC-33 prepared by the single screw extruder.....	107
Table B-4	Tensile strengths of PC2405 and its blends with CBC-33 prepared by the single screw extruder.....	107
Table B-5	Tensile strengths of PC2600 and its blends with CBC-33 prepared by the twin screw extruder.....	108
Table B-6	Tensile strengths of PC2405 and its blends with CBC-33 prepared by the twin screw extruder.....	108
Table B-7	Modulus of elasticity values of PC2600 and its blends with CBC-33 prepared by the internal mixer.....	109
Table B-8	Modulus of elasticity values of PC2405 and its blends with CBC-33 prepared by the internal mixer.....	109
Table B-9	Modulus of elasticity values of PC2600 and its blends with CBC-33 prepared by the single screw extruder.....	110
Table B-10	Modulus of elasticity values of PC2405 and its blends with CBC-33 prepared by the single screw extruder.....	110

LIST OF TABLES (continued)

	Page
Table B-11 Modulus of elasticity values of PC2600 and its blends with CBC-33 prepared by the twin screw extruder.....	111
Table B-12 Modulus of elasticity values of PC2405 and its blends with CBC-33 prepared by the twin screw extruder	111



สถาบันวิทยบริการ
จุฬาลงกรณ์มหาวิทยาลัย

LIST OF FIGURES

	Page
Figure 3-1 The general chemical structure of polycarbonate.....	11
Figure 3-2 The structure of polyethylene	14
Figure 3-3 The structure of MC-PLCs and SC-PLCs.....	18
Figure 3-4 The structure of MC-PLC	19
Figure 3-5 The structure of MC-PLC	19
Figure 3-6 The random orientation of monomers in the polymer chain.....	20
Figure 3-7 The irregularity of polymer substitute in polymer chain.....	20
Figure 3-8 120- degree kinks in the polymer chain.....	20
Figure 3-9 The structure of SC-PLCs	21
Figure 3-10 The spacer of methylene units and the mesogen of aromatic rings.....	21
Figure 3-11 The tangle conformation and orientation of the mesogens.....	22
Figure 3-12 The structure of smectic phase.....	24
Figure 3-13 The structure of nematic phase.....	24
Figure 3-14 The structure of cholesteric phase.....	25
Figure 3-15 The general structure of aromatic system.....	27
Figure 3-16 The general structure of alicyclic system.....	28
Figure 3-17 The structure of cholesteric system.....	29
Figure 3-18 The structure of diskogens system.....	30
Figure 3-19 Schematic diagram of the miniaturized internal mixer.....	32
Figure 3-20 Schematic of single screw extruder.....	34
Figure 3-21 The melting mechanism of polymer in a single screw extruder.....	35
Figure 3-22 Melting progression in a single screw extruder.....	36
Figure 3-23 Schematic of twin screw extruder.....	36
Figure 3-24 Chamber-to-chamber material flow pattern in co-rotating and counter rotating twin screws.....	37
Figure 3-25 A single screw injection molding machine for thermoplastics.....	38
Figure 3-26 A single screw injection molding machine for thermoplastics, showing the plasticizing screw, a barrel, band heaters to heat the barrel, a stationary platen, and a movable platen.....	38
Figure 3-27 A reciprocating screw, showing the feeding zone, compressing zone and metering zone.....	39

LIST OF FIGURES (continued)

	Page
Figure 3-28 (a) Nozzle with barrel in processing position	
(b) Nozzle with barrel backed out for purging.....	39
Figure 3-29 A typical (three-plate) molding system.....	40
Figure 3-30 A three-plate mold.....	41
Figure 3-31 The molded system includes a delivery system and molded parts.....	41
Figure 4-1 The structure of poly (bisphenol A carbonate).....	43
Figure 4-2 The structure of polyethylene.....	44
Figure 4-3 The structure of CBC-33.....	44
Figure 4-4 The structure of BCH-5.....	45
Figure 4-5 Tensile testing machine.....	48
Figure 4-6 Scanning electron microscope.....	49
Figure 4-7 Chart of all methods of experiments.....	50
Figure 4-8 Tensile testing specimen.....	61
Figure 5-1 Torque values of the internal mixer used when melting the blends at various concentrations of the master batch of BCH-5 and rotor speeds.....	66
Figure 5-2 Mechanical Properties of PC2600 and its blends prepared by the internal mixer.....	78
Figure 5-3 Mechanical Properties of PC2405 and its blends prepared by the internal mixer.....	79
Figure 5-4 Mechanical Properties of PC2600 and its blends prepared by the single screw extruder.....	80
Figure 5-5 Mechanical Properties of PC2405 and its blends prepared by the single screw extruder.....	81
Figure 5-6 Mechanical Properties of PC2600 and its blends prepared by the twin screw extruder.....	82
Figure 5-7 Mechanical Properties of PC2405 and its blends prepared by the twin screw extruder.....	83
Figure 5-8 DSC thermogram of pure PC2600 before blending by the twin screw extruder.....	85
Figure 5-9 DSC thermogram of pure PC2600 after blending by the twin screw extruder.....	86
Figure 5-10 DSC thermogram of PC2600 blended with master batch of CBC-33 after blending by the twin screw extruder.....	87

LIST OF FIGURES (continued)

	Page
Figure 5-11 DSC thermogram of PC2600 remix after blending by the twin screw extruder	88
Figure 5-12 GPC chromatogram of pure PC2600 before blending by the internal mixer	90
Figure 5-13 GPC chromatogram of pure PC2405 before blending by the internal mixer	90
Figure 5-14 GPC chromatogram of pure PC2600 after blending by the internal mixer	91
Figure 5-15 GPC chromatogram of PC2600 blended with master batch of CBC-33 after blending by the internal mixer	91
Figure 5-16 GPC chromatogram of PC2600 remix after blending by the internal mixer	92
Figure 5-17 GPC chromatogram of pure PC2405 after blending by the internal mixer	92
Figure 5-18 GPC chromatogram of PC2405 blended with master batch of CBC-33 after blending by the internal mixer	93
Figure 5-19 GPC chromatogram of PC2405 remix after blending by the internal mixer	93
Figure 5-20 Scanning electron micrographs of fracture surfaces of PC2600 and its blends prepared by the internal mixer (A) Pure PC2600 (B) PC2600 blended with master batch of CBC-33 (C) PC2600 remix	95
Figure 5-21 Scanning electron micrographs of fracture surfaces of PC2405 and its blends prepared by the internal mixer (A) Pure PC2405 (B) PC2405 blended with master batch of CBC-33 (C) PC2405 remix	95
Figure 5-22 Scanning electron micrographs of fracture surfaces of PC2600 and its blends prepared by the single screw extruder (A) Pure PC2600 (B) PC2600 blended with master batch of CBC-33 (C) PC2600 remix	95
Figure 5-23 Scanning electron micrographs of fracture surfaces of PC2405 and its blends prepared by the single screw extruder (A) Pure PC2405 (B) PC2405 blended with master batch of CBC-33 (C) PC2405 remix	96
Figure 5-24 Scanning electron micrographs of fracture surfaces of PC2600 and its blends prepared by the twin screw extruder (A) Pure PC2600 (B) PC2600 blended with master batch of CBC-33 (C) PC2600 remix	96
Figure 5-25 Scanning electron micrographs of fracture surfaces of PC2405 and its blends prepared by the twin screw extruder (A) Pure PC2405 (B) PC2405 blended with master batch of CBC-33 (C) PC2405 remix	96
Figure 5-26 Torque values of the internal mixer, single screw extruder and twin screw extruder used when melting pure PC2600 and its blends with CBC-33	99

LIST OF FIGURES (continued)

	Page
Figure 5-27 Torque values of the internal mixer, single screw extruder and twin screw extruder used when melting pure PC2405 and its blends with CBC-33.....	99
Figure A-1 Critical values for student.....	102



สถาบันวิทยบริการ
จุฬาลงกรณ์มหาวิทยาลัย

CHAPTER 1

INTRODUCTION

1.1 General Introduction

Polymeric materials, which are well known under the common name “Plastics”, are very important and useful at present because of their high ratio of properties per weight comparing to existing materials such as metals or woods. They can be used in various useful applications for example household appliances, insulation, and electronic equipments. These products required a wide range of different properties that polymer can be provided for each application.

Polymeric materials [1] can increase their utilities by the polymer processing that is a engineering specialty concerned with the operations of producing one or more of the following effects, chemical reaction, flow or a permanent change in physical properties in the manufacture of resins. One method of classifying polymer conversion operations is based on end products function. Operations can be grouped into three broad categories. The operations in the first category have to form a mass of the polymer into a useful shape that are molding, extrusion and calendaring. Operations in the second category have the function of bonding that are heat-sealing, laminating or coating. The third category of operations have the function of modifying the structure of the polymer system that are mixing, surface activation or polymer modification.

Molding and extrusion are the basic forming techniques of polymer processing. Since the molding can fix three dimensions (height, width and length) of an object, while the extrusion die can fix only two dimensions (height and width), extrusion and molding are usually complementary rather than competitive operations. There are many different types of molding operations but the most well-known is injection molding that a thermoplastic material is heated above its softening point to obtain flow and then cooled below its softening point to obtain solidification, a purely physical process. In extrusion the polymer is shaped by being forced through a die in the fluid state and then solidified while it retains the shape imparted to it by the die. Extrusion operations are used in the manufacture of film, fibers, pipe and other shapes, in coating paper, metal, foils, wire and in many other ways.

Polycarbonate [2] is a kind of engineering polymer that is water-clear material, easily colored and is adaptable to a variety of molding processes but it has high melt viscosity. In order to decrease the processing viscosity, we need to increase the processing temperature or we need to add the additives such as lubricant or plasticizer, but those additives may cause many negative effects to other important properties of polymers especially mechanical properties of the final products.

Lubricant [3] is a substance that when added in small quantities, provides a considerable decrease in resistance to the movement of chains or segments of a polymer or at least partly amorphous structure. There are two kinds of lubricant that are internal lubricant and external lubricant. In general, if a lubricant appears to be effective in improving flow but does not have much effect on surface tension, it is considered internal lubricant. If it is found on the surface or on adjacent surfaces, or if it modifies observables associated with the surface, it is considered external lubricant. If it behaves in one way under one set of conditions and in another way under a different set of circumstances, it is considered both an internal and external lubricant. These are referred to as "balanced," "combination," or "multifunctional" lubricants.

Liquid crystal polymers (LCP) are the polymers whose molecules can be aligned in some certain directions. The most common liquid crystal is the liquid crystal display (LCD). The liquid crystal of LCD aligned their molecules subjected to apply electricity. There are other liquid crystals that aligned their molecules subjected to heat (thermotropic liquid crystal), or when dissolves in solvents (lyotropic liquid crystal). The lyotropic liquid crystalline is usually used in fiber forming processes. The thermotropic liquid crystalline is usually used in melt mixing processes. In this research, we are concerned about the thermotropic liquid crystal.

Polymer blends [4] have been one of the most promising routes to produce new materials. Blending is an efficient means to create new materials having many more varied physical properties than do the individual polymers. There were many ways to mix polymers together such as by heat (melt mixing), by using solvent (solution casting, freeze-drying) and others. The primary properties, at which improvements are aimed in blending, are mechanical, thermal properties and cost per processability.

Novel properties have been found when blending conventional thermoplastics with liquid crystal polymers. Liquid crystal polymers were known as a new class of engineering polymers. The main purpose of blending liquid crystal polymers into isotropic polymer is decreased the viscosity and increased the mechanical properties. Oriented liquid crystal polymers can lubricate the polymer melt and reduce the melt viscosity. The reductions of the viscosity of blends allow to reduce the processing temperatures.

There have been a considerable number of papers in the literatures dealing with phase transitions, characterization of mesophase (the phase that molecules of liquid crystal have an alignment), flow behavior and mechanical properties of these materials. For example, Nobile, M.R. [5] added about 5% and 10% by weight of liquid crystal polymers in polycarbonate, the viscosity of the blends reduces about 30% and 50% respectively, when compare with the pure polycarbonate. In this research, the blends of low molecular weight liquid crystal were study in stead of liquid crystal polymer and the amount of liquid crystal was used only 0.2% by weight.

In United State patent [4,434,262], Buckley, A., Conciatori, A.B., and Calundann, G.W. [6] studied and improved melt processable blend comprising of a polymer selected from the group consisting of a polyolefins and a polyester and a low molecular weight liquid crystal compound which is capable of forming an anisotropic melt phase at the melt processing temperature of the blend.

Consequently, the presents study deals with a system composed of thermoplastic polycarbonates and low molecular weight liquid crystal (LCC). The low molecular weight liquid crystal, CBC-33, from Merck Company Limited was chosen to blend with polycarbonate because the melting viscosity of polycarbonate is very high and it is difficult to process this material. The reason for choosing this liquid crystal because it has nematic region between the processing temperature of polycarbonate.

1.2 The Objectives of the Present Study

Study on the effects of low molecular weight liquid crystal blend with polycarbonates that influence on the mechanical properties and thermal properties of the polymer blends by using various polymer processing instruments.

1.3 The Scope of the Present Study

The present report was concerned with two polycarbonates, having the different molecular weights, were blended with low molecular weight liquid crystal (CBC-33) at concentration about 0.2% by weight by using the internal mixer, single screw extruder and twin screw extruder. The torque of the instruments used when melting pure polycarbonates and the blends with low molecular weight liquid crystal were determined. The mechanical properties were determined by tensile testing specimens from the injection molding machine. The thermal properties were determined by Differential Scanning Calorimetry (DSC), the molecular weight distributions were determined by Gel Permeation Chromatography (GPC) and the morphology of blends were observed by Scanning Electron Microscopy (SEM).



สถาบันวิทยบริการ
จุฬาลงกรณ์มหาวิทยาลัย

CHAPTER 2

LITERATURE REVIEW

Polymeric blends of melt processable polymers and liquid crystalline compounds have been studied in many researches. This review covers liquid crystalline (LC) blends containing either low molecular weight liquid crystal or high molecular weight liquid crystal. The main reason of blending high molecular weight liquid crystalline compound (liquid crystal polymer, LCPs) with other polymers is improved the mechanical properties of matrix polymer. Only few researchers have studied about low molecular weight liquid crystal blends for improving the melt viscosity of the blends.

Buckley, A. Conciatori, A.B. and Calundann, G.W. [1984] [6] investigates the blends of low molecular weight liquid crystalline compound with either polyolefin or polyester. The low molecular weight liquid crystalline compound (LCC) used have molecular weight less than about 1,000 g/mol. The LCC used came from the group consisting of N,N'-bis (p-methoxybenzylidene)-alpha,alpha]-bi-p-toluidine, p-methoxycinnamic acid, N,N]-bis(4-octyloxybenzylidene)-p-phenylenediamine. The concentration of low molecular weight liquid crystalline used is present in an amount of from about 0.5 to 5 % by weight and the melt viscosity of the blend was determined by a capillary rheometer. The melt viscosity of low molecular weight liquid crystalline blends reduced by as much as 25 to 30% compared with the pure matrix polymers.

Siegmann, A., Dagan, A., and Kenig, S. [1985] [7] prepared the polymer blends of liquid crystalline aromatic copolyester (based on 6-hydroxy-2-naphthanoic acid (HNA) and p-hydroxybenzoic acid) and an amorphous polyamide (PA) by melted mixing method. The rheological behavior of the blends was very different from pure component and viscosity of blends significantly changed. Only 5 % by weight of LCP in the blend could reduce the viscosity 20-25 times. The tensile mechanical behavior of the blends was very similar to that of polymeric matrix. The blend of two phase morphologies was found to be affected by the LCP compositions. The LCP phase changed gradually with increasing LCP content form ellipsoidal particles to rod-like and fibrillar structure.

Blizard, K.G., and Baird, D.G., [1987] [8] characterized the morphology and rheology of the blends between either polycarbonate or nylon 6,6 with the copolyester comprise 60 mole percent p-hydroxybenzoic acid/40 mole percent poly(ethylen terephthalate). The characterize processes were performed under different processing conditions. In particular, the single screw extrusion, steady simple shear flow, and flow through a capillary were studied to determine what conditions were necessary for the development of a fibrillar morphology of the liquid crystalline polymer blends. The results indicate that some extension of the particulate LCP phase occurred. The viscosity of the blends was determined both in a cone-and-plate geometry of a rheometrics mechanical spectrometer at low shear rates and in the Instron capillary rheometer at higher shear rates. In general, only a small (10 to 30%) weight fraction of LCP was required to reduce the viscosity of the thermoplastics to that of the polymeric liquid crystal.

Nobile, M.R., Amendola, E., and Nicolais, L., [1989] [5] investigated the blends of polycarbonate and poly(ethylene terephthalate-co-p-oxybenzoate) that prepared by the single screw extrusion. Physical and chemical interactions between the two phases of the system were studied by thermal analysis and infrared spectroscopy. Rheological measurements in shear flow were carried out both in the low and high shear rate regions in the temperature range of the existence of the mesophase. At low liquid crystalline polymer content, the blends showed flow curves similar to those of the unfilled, while at high content the rheological behavior of the pure LCP was resembled. Moreover, in the whole shear range, the viscosity values of such blends were in between those of the pure polymers. The influence of the addition of 10% LCP on the mechanical properties of the PC was investigated. The PC tensile modulus has a plateau of 3.1 GPa, while the blend's tensile modulus reaches a value of 4.4 GPa (about 50% higher than the corresponding matrix one). Fiber-spinning was performed under different experimental conditions, and it was found that opportune drawing conditions are necessary to improve that modulus of the matrix. Morphological analyses of the pure LCP and of the blends were related to the rheological and mechanical behavior of these systems.

Tariq M. Malik, Pierre J. Carreau and Nathalie Chappleau [1989] [9] investigated the mechanical and rheological properties of blends of a thermotropic liquid crystalline polyester with a polycarbonate. The blends are fibrillar in character and exhibit great hardness and toughness due to high degree of molecular orientation, which develops during the melt blending and processing steps. Increases of the Young modulus by 100 percent are observed for blends containing only 10 percent of liquid crystalline polymer (LCP). Time-dependent behavior of the blends was investigated by performing solid state relaxation measurements and the relaxation modulus was also found to

increase by the addition of LCP. The effect is relatively small in the glassy zone of viscoelastic response, but increases through the transition and viscous flow regions. The melt viscosity of the polycarbonate is slightly shear thinning whereas that of the unblended LCP increases rapidly with decreasing shear rate at low shear rate. This suggests the presence of yield stresses as confirmed by measurements on the Rheometrics RSR in the stress sweep mode. The melt viscosity of the blends was found to be similar to that of the unblended polycarbonate, but more shear thinning and less viscous. Preliminary results of scanning electron microscopy (SEM) showed the extended filaments of LCP are composed of fibers and fibrils oriented parallel to the tensile axis. Micrographs of blend containing 2.5, 5 and 10 percent LCP show homogeneous dispersion of the fibers in the PC matrix. These micrographs also suggest very good wetting and adhesion between the fibers and matrix. For the 25/75 percent LCP/PC blend, large voids and heterogeneities appear showing very poor wetting and lack of adhesion between the two polymers; they show as well lack of dispersion of fibers in the PC matrix. These void and poor dispersion properties at the higher LCP content.

Cottis, S., Chin, H., Shiau, W., and Shopland, D., [1991] [10] studied the polymer molding compositions containing polycarbonates, polyesters and liquid crystalline polymers (copolyesters of p- hydroxybenzoic acid and 2-hydroxy-6-naphthanoic acid). The compositions of blends were 10 to 30 wt% LCP, 90 to 10 wt% polycarbonate and 10 to 90 wt% polyester. The polymer compositions are prepared by two-step melt processing method, by twin conical non-vented screw extruder, with produces a unique microscopic morphology and improved toughness properties over conventional LCP blends. The excellent toughness and ductility properties were obtained when the molding composition contains a major amount of polycarbonate as the matrix resin.

Beery, D., Kenig, S. and Siegmann, A. [1991] [11] studied the microstructure development during capillary flow of polymer blends containing liquid crystal polymer that was consist of 30 mole percent 6-hydroxy-2-naphthanoic acid and 70 mole percent of p- hydroxybenzoic acid. In the present investigation the wholly aromatic LCP constituent was the minor phase suspended in the polycarbonate, poly(butylene terephthalate) or Nylon-6. Experimental results showed that the viscous forces acting at the component interface were predominated the elongational deformation and the resulting structure development of the LCP phase. In cases where the viscosity of the suspending matrix was higher than the LCP one (PC and Nylon-6), SEM indicated that fibrillar structure developed. In cases where the viscosity of the matrix polymers was lower than the LCP suspended phase, fibrous structures developed only at very high shear rates. Due to velocity rearrangement effects at the capillary exit, a skin core morphology was observed. Since the polymer viscosity

depends both on shear rate and temperature, the *in situ* composite structure development depends on the specific processing methods and conditions that the LCP containing polyblends experience.

Beery, D., Kenig, S. and Siegmann, A. [1992] [12] studied the shear and elongational viscosities of a thermotropic liquid crystalline polymer (LCP), polycarbonate (PC), and their 20%LCP in 80%PC blend by using a capillary rheometer. The LCP was aromatic copolyester, composed of hydroxybenzoic acid (HBA) and hydroxynaphthoic acid (HNA) with 73/27 molar ratio. Experimental results have shown that shear viscosities and entrance pressured are practically independent of the entrance angles. The entrance pressure drop was small in the case of PC and the reached 50% of the total pressure drop for LCP. The 20%LCP blend exhibits intermediate viscosity values. The elongational viscosities of the three materials studied are the function of elongation rate, and can be described by power law equations.

Lin, Y.C., Lee, H.W. and Winter, H.H. [1993] [13] studied the miscibility and viscoelastic properties of blends of a segmented block copolyester that had the average molecular weight 11,500 g/mol and poly (ethylene terephthalate) that had the average molecular weight 50,000 g/mol . They found that addition of a small quantity of LCP has a dramatic effect on rheology. For example, an addition of 2 wt% LCP reduces the viscosity by about 60%. This effect is most pronounced for PET of higher molar masses. The melt viscosity decreases exponentially with the LCP content in the range of composition where the blends are miscible. But there was no significant further reduction of viscosity when the LCP content exceeds 50 wt%. The addition of LCP also changes the distribution of the relaxation times of PET and broadens the zero shear viscosity regimes.

He, Jiasong and Bu, Wensheng [1994] [14] studied microstructure formation in polyblends containing liquid crystalline polymers. Based on rheological data, two polyblends of poly (ether sulfone) (PES) and polycarbonate (PC) with liquid crystalline polymer (LCP) as the dispersed phase were prepared by extrusion. The process of LCP microstructure formation was investigated by studying the morphology of the blend obtained from different sections of the extruder. The deformation of LCP domains is controlled by the viscosity ratio of the dispersed phase to the continuous phase. LCP domains in LCP/PES blend have been deformed into oriented fibrils, due to a viscosity ratio of 0.01. A quantitative comparison of LCP droplet size before and after the extruder die shows that the morphology of extrudates has been determined before the melt enters the die. After the die, the diameter and length to diameter ratio of LCP fibrils were increased by coalescence and further deformation by the action of extensional flow. The morphology of LCP/PES extrudates after remaining at quiescence within the die for different time intervals indicates that even after a 60 s

residence, LCP domains retained their fibrillar structure in the blend and no significant recoiling and breakup of LCP fibril occurred.

Anchana Chuenchaokit [1998] [15] studied the effects of thermotropic liquid crystals on properties of polycarbonates. The low molecular weight liquid crystals were cyclohexyl-biphenylcyclohexanes groups that had average molecular weight about 400 g/mol. The blends were prepared by melt mixing at 0.25, 0.5 and 1% by weight of liquid crystals. The shear viscosity of pure PC and their blends were investigated using a capillary rheometer and the glass transition temperatures were measured by Differential Scanning Calorimeter (DSC). Experimental results showed that the viscosity of the blends with only small weight fraction (1%) of low molecular weight liquid crystal is about 90 percent lower than that of the pure polycarbonates. DSC thermograms also show the decreasing in the glass transition temperatures of PC.

Suraphan Powanusorn [2000] [4] prepared the blends of low molecular weight liquid crystal and nylon-6, polyethylene, polypropylene, polycarbonate and polyacetal. The low molecular weight liquid crystals had average molecular weight about 400 g/mol. Melt mixing was the preparation method for blending liquid crystal and base polymers together at 0.1, 0.2, 0.4% by weight of liquid crystal. The rheological, thermal and mechanical properties of the blends are investigated in order to compare with the base polymer that absence of liquid crystal. The results show that liquid crystal may improve the processability of the base polymer by reducing the melt viscosity while the liquid crystal did not affect the thermal and mechanical properties of the base polymer. The melt viscosity of the blends is about 20 to 80 percent lower than that of the base polymer depended on type of polymers at the some shear rate.

Sayant Saengsuwan and Sauvarop Bualek-Limcharoen [2003] [16] studied thermotropic liquid crystalline polymer (Rodrun LC5000)/polypropylene in situ composite films: rheology, morphology, molecular orientation and tensile properties. In situ composite films were prepared by a two-step method. First, polypropylene and thermotropic liquid crystalline polymer (TLCP), Rodrun LC5000 (80 mol% *p*-hydroxy benzoic acid (HBA)/20 mol% polyethylene terephthalate (PET)), were melt blended in a twin-screw extruder and then fabricated by extrusion through a mini- extruder as cast film. Rheological behavior of the blends, morphology of the extruded strands and films, and tensile properties of the in situ composite films were investigated. Rheological behavior of the blends at 295 °C studied using a plate-and-plate rheometer revealed a substantial reduction of the complex viscosity with increasing TLCP content, and all specimens exhibited shear thinning behavior. Over the angular frequency range of 0.6–200 rad/s, the viscosity ratio (dispersed phase to matrix phase)

was found to be very low, in the range of 0.03–0.07. Morphologies of the fracture surfaces of the blend extrudates and the film surfaces etched in permanganic solution were investigated by scanning electron microscope (SEM). The TLCP droplets in the extruded strands were seen with a progressive deformation into fibrillar structure when TLCP content was increased up to 30 wt%. In the extruded films, TLCP fibrils with increasing aspect ratio (length to width) were observed with increasing TLCP concentration. Orientation functions of each component were determined by X-ray diffraction using a novel separation technique. It was observed that the Young's modulus in machine direction of the extruded film was greatly improved with increasing TLCP loading, due to the increase in fiber aspect ratio and also molecular orientation.



สถาบันวิทยบริการ
จุฬาลงกรณ์มหาวิทยาลัย

CHAPTER 3

THEORIES

3.1 Poly(bisphenol A carbonate) [2]

There are few thermoplastics that have the outstanding engineering properties as polycarbonate. In recent years, it has taken its place among the most valuable resins of the industry. Polycarbonate is a member of the polyester family; it contains carbon and oxygen atoms as the backbone of the molecular chain. The plastics industries are using polycarbonate in direct competition with nylon and acetal as well as metals like copper, zinc and brass.

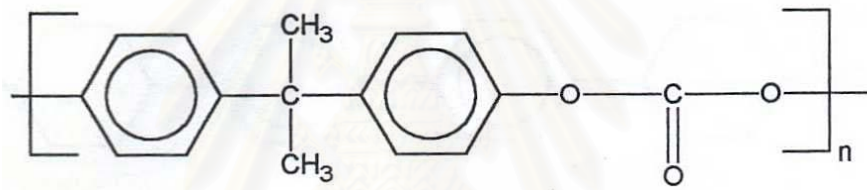

Figure 3-1 The general chemical structure of polycarbonate. [2]

3.1.1 Characteristics of Polycarbonate

One of the toughest of all plastics, polycarbonate meets many of the extreme properties of plastics. It is available in granular and sheet form ready for molding or fabricating. This polymer is a water-clear material, easily colored and is adaptable to a variety of molding processes including injection, extrusion, and blow molding. Five outstanding properties of polycarbonate which in combination, separate it from other thermoplastic material are:

1. Good electrical properties which meet the needs of electrical and electronic industries.
2. Outstanding impact strength that makes it useful for long service life under extreme heavy-duty conditions.
3. The transparency of polycarbonate approximates that of the light transmission of the acrylics and glass.

4. Superior dimensional stability qualifies its usage in precision-engineered components where close tolerances are required.
5. The self-extinguishing properties of polycarbonate make it useful in applications involving high temperature use where safety hazards may exist.

Polycarbonate also contains the average properties of many other plastics. These include good machinability and good chemical resistance. It can be attacked by some low molecular weight hydrocarbons and can be dissolved in ethylene dichloride.

3.1.2 Product Applications

The outstanding properties of polycarbonate make it suitable for applications where other thermoplastics are inadequate. Polycarbonate street lighting globes are easily blow molded and are not brittle like glass. This advantage shows up in products like protective facemasks covers for electrical panels, electrical insulations and windowpanes for buildings. Other applications of polycarbonate include safety helmets, sunglass lenses, blow molded bottles, coffee pots and housings for shavers.



สถาบันวิทยบริการ
จุฬาลงกรณ์มหาวิทยาลัย

Table 3-1 Properties of polycarbonate. [17]

Properties	ASTM	value
Processing		
Tg (°C)		150
Compression molding temp. (°F)		480-620
Compression molding pressure (psi)		1000-2000
Injection molding temp. (°F)		480-650
Injection molding pressure (psi)		10000-20000
Compression ratio		1.74-5.5
Mold(linear) shrinkage (in./in.)		0.005-0.007
Specific gravity	D792	1.2
Mechanical		
Tensile strength (psi)	D638	8000-9500
Elongation (%)	D683	100-130
Compressive strength (psi)	D695	12500
Flexural strength (psi)	D790	13500
Impact strength (ft-lb/in. of notch)	D256	12-18
Hardness (Rockwell)	D785	M70-78, R115-125
Flexural modulus (10 ⁵ psi at 73 °F)	D790	3.2-3.5
Tensile modulus (10 ⁵ psi)	D638	3.0-3.5
Compressive modulus (10 ⁵ psi)	D695	3.45
Thermal		
Thermal conductivity	C177	4.6
Specific heat (cal./°C/g)		0.28-0.30
Thermal expansion (10 ⁻⁵ in./in./°C)	D696	6.6
Deflection temp. at 264 psi (°F)	D648	265-285
Electrical		
Volume resistivity (ohm-cm)	D257	10 ¹⁶
Dielectric strength (volts/mil)	D149	380
Dielectric constant (60Hz)	D150	2.97-3.17
Dissipation (power) factor (60Hz)	D150	0.0007
Arc resistance (sec)	D495	10-120
Optical		
Refractive index	D542	1.586
Transmittance (%)	D1003	85-91
Haze (%)	D1003	0.5-2.0

3.2 High Density Polyethylene, HDPE [2]

Polyethylene is the major of a group of chemical compounds known as polyolefins. It is one of the most widely used polymers of the thermoplastic materials. Polyethylene is produced in two forms in terms of density. Low and intermediate density polyethylenes are produced with a relatively short chain molecular structure and a high degree of side branching. This structure provides a polymer with approximately 65 percent crystallinity. On the other hand, high density polyethylene is polymerized to form much longer linear chains with few side branches. This results in a greater density and a crystallinity range of 85 percent.

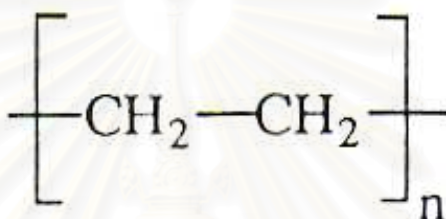

Figure 3-2 The structure of polyethylene. [2]

3.2.1 Characteristics of High Density Polyethylene

Polyethylene appears in its natural form as a milky white, waxy feeling material. In general, as the density increase, the stiffness, hardness, strength, heat distortion point, and ability to transmit gasses increases. As density decreases, impact strength and stress crack resistance increases. The following factors sum up the general properties of polyethylene:

1. Very tough at low temperatures.
2. Excellent chemical resistance.
3. High permeability to air and gasses.
4. Low in water vapor transmission.
5. Fairly high mold shrinkage.
6. Flexibility is good to excellent, even to -100°F .
7. Weatherability is fair, can be improved by adding carbon black.
8. Excellent electrical insulating properties.
9. Easily colored in transparent (film), translucent or opaque material.
10. Odorless and tasteless.

3.2.2 Product Applications

Polyethylene is used for many purposes, including containers, electrical insulation, housewares, chemical tubing, toys, freezer bags, and battery parts. Two major applications of polyethylene are films for packaging soft goods and other nonperishables and blow molded bottles.



สถาบันวิทยบริการ
จุฬาลงกรณ์มหาวิทยาลัย

Table 3-2 Properties of high density polyethylene. [17]

Properties	ASTM	value
Processing		
Tm (°C)		120-140
Compression molding temp. (°F)		300-450
Compression molding pressure (psi)		500-800
Injection molding temp. (°F)		300-600
Injection molding pressure (psi)		10000-20000
Compression ratio		2.0
Mold(linear) shrinkage (in./in.)		0.02-0.05
Specific gravity	D792	0.941-0.965
Mechanical		
Tensile strength (psi)	D638	3100-5500
Elongation (%)	D683	20-1300
Compressive strength (psi)	D695	2700-3600
Flexural strength (psi)	D790	-
Impact strength (ft-lb/in. of notch)	D256	0.5-20.0
Hardness (Rockwell)	D785	D60-D70 (Shore)
Flexural modulus (10 ⁵ psi at 73 °F)	D790	1.0-2.6
Tensile modulus (10 ⁵ psi)	D638	0.6-1.8
Compressive modulus (10 ⁵ psi)	D695	-
Thermal		
Thermal conductivity	C177	11.0-12.4
Specific heat (cal./°C/g)		0.55
Thermal expansion (10 ⁻⁵ in./in./°C)	D696	11.0-13.0
Deflection temp. at 264 psi (°F)	D648	110-130
Electrical		
Volume resistivity (ohm-cm)	D257	>10 ¹⁶
Dielectric strength (volts/mil)	D149	450-500
Dielectric constant (60Hz)	D150	2.30-2.35
Dissipation (power) factor (60Hz)	D150	<0.0005
Arc resistance (sec)	D495	-
Optical		
Refractive index	D542	1.54
Transmittance (%)	D1003	0-40
Haze (%)	D1003	10-50

3.3 Liquid Crystal

3.3.1 The History of Liquid Crystal [18]

The discovery of liquid crystals has been approximately occurred 150 years ago, although its significance was not fully realized until over a hundred years later. Around the middle of the last century, Virchow, Mettenheimer and Valentin found from their research that the nerve fiber formed a fluid substance when left in water that exhibited a strange behavior when it was viewed by polarized light. They did not realize this as a different phase, but they are attributed with the first observation of liquid crystal. Later, in 1877, Otto Lehmann used a polarizing microscope with hot stage to investigate the phase transitions of various substances. He found that one substance would change from a clear liquid to a cloudy liquid before crystallizing but thought that this was simply an imperfect phase transition from liquid to crystalline. In 1888 Reinitzer conducted similar experiments and was the first to suggest that cloudy fluid was a new phase of matter. He has consequently been given the credit for the discovery of the liquid crystalline phase. Up till 1890 all the investigated liquid crystalline substances had been naturally occurred and it was the first synthetic liquid crystal, p-azoxyanisole, was produced by Gatterman and Ritschke. Subsequently, more liquid crystals were synthesized and it is now possible to produce liquid crystals with specific predetermined material properties.

In the beginning of this century George Freidel conducted many experiments on liquid crystals and firstly explained the orienting effect when applied electric fields in the presence of defects in liquid crystals. In 1922, he proposed a classification of liquid crystals based upon the different molecular orderings of each substance. It was between 1922 and the World War II that Oseen and Zocher developed a mathematical basis for the study of liquid crystals. After the war started, many scientists believed that the important features of liquid crystals had completely been discovered and it was not until the 1950's that work by Brown in America, Chistiakoff in the Soviet Union and Gray and Frank in England led to a revival of interest in liquid crystals. Maier and Saupe formulated a microscopic theory of liquid crystals, Frank and later Leslie and Ericksen developed continuum theories for static and dynamic systems and in 1968 scientists from Radio Corporation of America first demonstrated a liquid crystal display. The interest in liquid crystals has grown ever since.

3.3.2 Introduction to Liquid Crystal [19]

Polymer liquid crystals (PLCs) are a class of materials that combine the properties of polymers with those of liquid crystals. These hybrids show the same mesophases characteristic of ordinary liquid crystals, while still retained the useful and versatile properties of polymers.

Difference from normally flexible polymers, characteristics of the display liquid crystals have rod-like or disk-like elements called mesogens incorporated into their chains. The placement of the mesogens plays a large role in determining the type of PLC that is formed. Main-chain polymer liquid crystals or MC-PLCs are formed when the mesogens are themselves part of the main chain of a polymer. Conversely, side chain polymer liquid crystals or SC-PLCs are formed when the mesogens are connected as side chains to the polymer by a flexible bridge called the spacer.

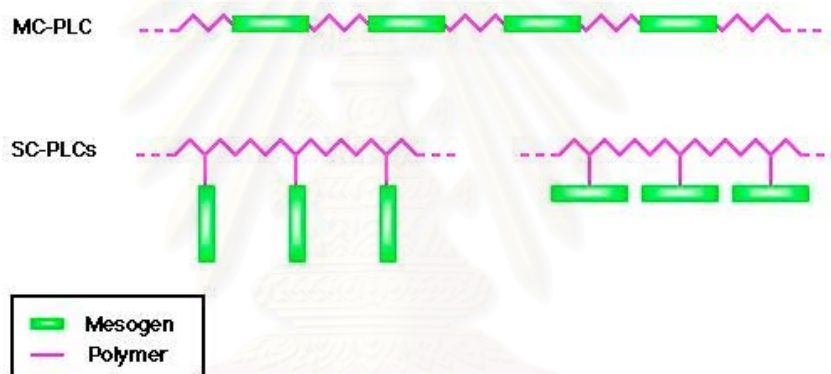

Figure 3-3 The structure of MC-PLCs and SC-PLCs. [19]

Other factors influencing the mesomorphic behavior of polymers include the presence of long flexible spacers, a low molecular weight, and regular alternation of rigid and flexible units along the main chain.

3.3.3 Main-Chain Polymer Liquid Crystals

Main chain polymer liquid crystals are formed when rigid elements are incorporated into the backbone of normally flexible polymers, these interact usually occur through a condensation reaction. These stiff regions along the chain allow the polymer to orient in a manner similar to ordinary liquid crystals, and thus display liquid crystal characteristics. There are two distinct groups of MC-PLCs, differentiated by the manner in which the stiff regions are formed. The first group of main chain polymer liquid crystals is characterized by stiff, rod-like monomers. These monomers are

typically made up of several aromatic rings which provide the necessary size. The following figure shows an example of this kind of MC-PLC.

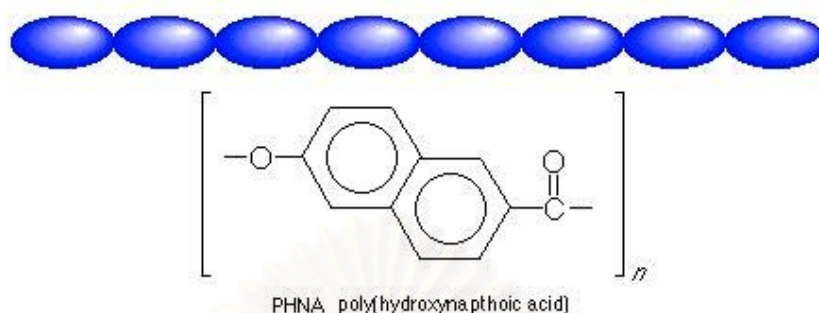

Figure 3-4 The structure of MC-PLC. [19]

The second and more prevalent group of main chain polymer liquid crystals is different because it incorporates a mesogen directly into the chain. The mesogen acts just like the stiff areas in the first group. Generally, the mesogenic units are made up of two or more aromatic rings which provide the necessary restriction on movement that allow the polymer to display liquid crystal properties. The stiffness is necessary for liquid crystallinity results from restrictions on rotation caused by steric hindrance and resonance this gives the polymer its stiffness. Otherwise, the molecules are not rod-like enough to display the characteristics of liquid crystals. This group is different from the first in that the mesogens are separated or "decoupled" by a flexible bridge called a spacer. Decoupling of the mesogens provides for independent movement of the molecules which facilitates proper alignment. The following is a figure of this type of main chain polymer liquid crystal. Notice the flexible spacer (methylene groups) and the stiff mesogen (aromatic ring and double bonds).

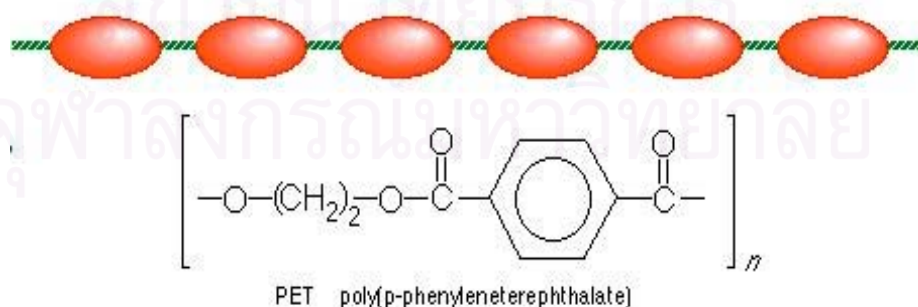

Figure 3-5 The structure of MC-PLC. [19]

It is difficult to create polymer liquid crystals that show mesogenic behavior over temperature ranges which are convenient to work with. In fact, many times the temperature of the liquid crystalline behavior is actually above the point where the polymer begins to decompose. This problem can be avoided in one or more of the following ways. The first method of lowering polymer melting temperatures involves the arrangement of the monomers in the chain. If the molecules are put together in random orientation (head-to-tail, head-to-head, etc.), interactions between successive chains are minimized. This allows for a lower melting temperature.



Figure 3-6 The random orientation of monomers in the polymer chain. [19]

Another method to bring the temperature down to a useful range involves copolymerization. If a random copolymer can be created, the regularity of the chains is greatly reduced. This will help to minimize the interactions between the chains by breaking up the symmetry, which in turn will lower polymer melting temperature. The following figure shows how the irregularity of polymer substitute can lead to decreased interactions.

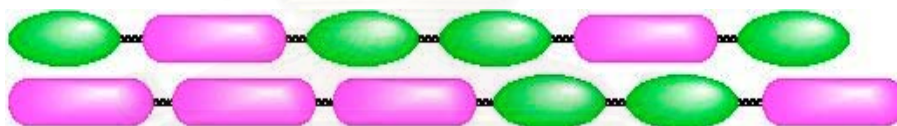

Figure 3-7 The irregularity of polymer substitute in polymer chain. [19]

Finally, defects can be introduced into the chain structure which lower the polymer melting temperature. This method creates 120-degree "kinks" in the chain which disrupt the ability for neighboring polymers to line up. Unfortunately, this also decreases the effective persistence length so too many kinks can destroy any liquid crystal behavior.

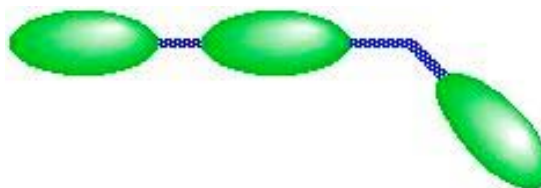

Figure 3-8 120-degree kinks in the polymer chain. [19]

3.3.4 Side Chain Polymer Liquid Crystals

It has been demonstrated that main chain polymer liquid crystals often cannot show mesogenic behavior over a wide temperature range. Side chain polymer liquid crystals are able to expand this scale. These materials are formed when mesogenic units are attached to the polymer as side chains which interact through a addition reaction.

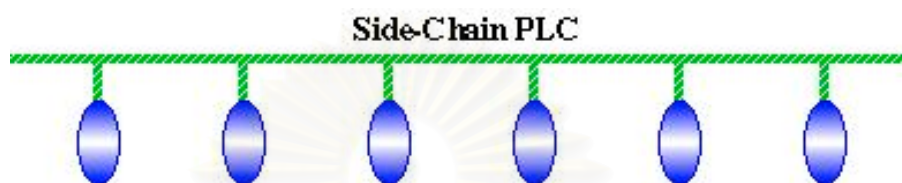

Figure 3-9 The structure of SC-PLCs. [19]

Side chain polymer liquid crystals have three major structural components: the backbone, the spacer, and the mesogen. The versatility of SC-PLCs arises because these structures can be varied in a number of ways.

The backbone of a side chain polymer liquid crystal is the element that the side chains are attached to. The structure of the backbone can be very important in determining if the polymer shows liquid crystal behavior. Polymers with rigid backbones typically have high glass transition temperatures, and thus liquid crystal behavior is often difficult to observe. In order to lower this temperature, the polymer backbone can be made more flexible.

Perhaps the most important part of a side chain polymer liquid crystal is the mesogen. It is the alignment of these groups that causes the liquid crystal behavior. Usually, the mesogen is made up of a rigid core of two or more aromatic rings joined together by a functional group. The following figure is a typical repeating unit in a side chain polymer liquid crystal. Notice the spacer of methylene units and the mesogen of aromatic rings.

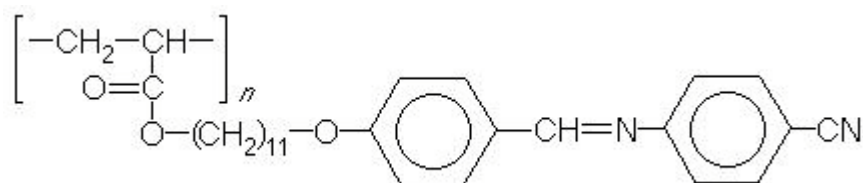

Figure 3-10 The spacer of methylene units and the mesogen of aromatic rings. [19]

Like their main chain counterparts, mesogens attached as side groups on the backbone of side chain polymer liquid crystals are able to orient because the spacer allows for independent movement. Notice in the following figure that even though the polymer may be in a tangled conformation, orientation of the mesogen is still possible because of the decoupling action of the spacer.



Figure 3-11 The tangle conformation and orientation of the mesogens. [19]

The structure of the spacer is an important determining factor in side chain polymer liquid crystals. Generally, the spacer consists of two to four methylene (CH_2) groups attached together in a line. Accordingly, the spacer length has a profound effect on the temperature and type of phase transitions. Usually, the glass transition temperature decreases with increasing spacer length. Short spacers lead to nematic phases, while longer spacers lead to smectic phases.

3.3.5 Type of Liquid Crystal [20]

Liquid crystals can be classified into two main categories:

1. Thermotropic liquid crystals
2. Lyotropic liquid crystals

These two types of liquid crystals are distinguished by the mechanisms that drive their self-organization, but they are also similar in many ways.

Thermotropic liquid crystals are occurred in most liquid crystals, and they are defined by the fact that the transitions to the liquid crystalline state are induced thermally. That is, one can arrive at the liquid crystalline state by raising the temperature of a solid and/or lowering the temperature of a liquid. Thermotropic liquid crystals can be classified into two types:

1. Enantiotropic liquid crystals, which can be changed into the liquid crystal state from either lowering the temperature of a liquid or raising of the temperature of a solid.
2. Monotropic liquid crystals, which can only be changed into the liquid crystal state from either an increase in the temperature of a solid or a decrease in the temperature of a liquid, but not both.

In general, thermotropic mesophases occur because of anisotropic dispersion forces between the molecules and because of packing interactions.

Lyotropic liquid crystal transitions occur with the influence of solvents, not by a change in temperature. Lyotropic mesophases occur as a result of solvent-induced aggregation of the constituent mesogens into micellar structures. Lyotropic mesogens are typically amphiphilic, meaning that they are composed of both lyophilic (solvent-attracting) and lyophobic (solvent-repelling) parts. This causes them to form into micellar structures in the presence of a solvent, since the lyophobic ends will stay together as the lyophilic ends extend outward toward the solution. As the concentration of the solution is increased and the solution is cooled, the micelles increase in size and eventually coalesce. This separates the newly formed liquid crystalline state from the solvent.

3.3.6 Liquid Crystal Phases

Friedel was able to distinguish clearly three different types of mesophase :

1. Smectic phase
2. Nematic phase
3. Cholesteric phase

Smectic phase begin from the word smectic that is derived from the Greek word “soap”, ironically the slippery substance found out the bottom of a soap dish is actually a type of smectic liquid crystal. The smectic phase is the most ordered state, where all the mesogens are arranged in a parallel and lateral order. Although this state is rare and is only observed for thermotropic polymers. In this phase the liquid crystal is turbid and the viscosity is rather high.



Figure 3-12 The structure of smectic phase. [18]

Nematic phase, the molecules having no positional order but tend to point in the same direction characterize this phase. It is observed that the mesogens are arranged in parallel order but do not have lateral order. Also aromatic polyamides (aramid) form a nematic order when mixed in a heavy concentration of solution. In this phase the liquid crystal is turbid but the viscosity is decrease, the molecules can move because it is mobile state.



Figure 3-13 The structure of nematic phase. [18]

Cholesteric phase occurs when the mesogens are arranged parallel to each other, but the directions vary from one layer to the next. In this phase the liquid crystal is turbid but the viscosity is decrease, the molecules can move because it is mobile state, exhibiting some unique optical characteristics, quite different form those of the smectic and nematic phases. The majority of compounds exhibiting this type of mesophase are derived from cholesterol or other sterol systems.

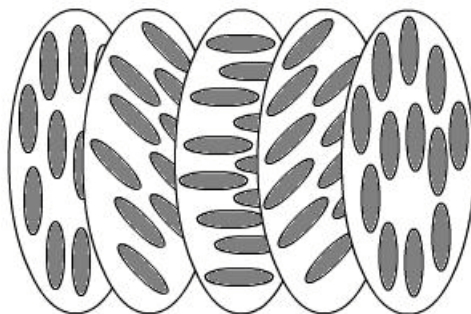

Figure 3-14 The structure of cholesteric phase. [18]

3.3.7 Mesophasic Transition Temperature [21]

The various transitions that liquid crystal undergo as the temperature increases from the most ordered to the least ordered states, can be shown



The temperature that a liquid crystal change from crystal to the smectic phase is called “crystalline melting temperature”.

The temperature that liquid crystal change from smectic phase to nematic phase is called “S-N transition temperature”.

The temperature that liquid crystal change from nematic phase to isotropic liquid is called “clearing temperature”.

The example of mesophasic transition temperature of low molecular weight liquid crystal used in this study (CBC-33) is shown below.

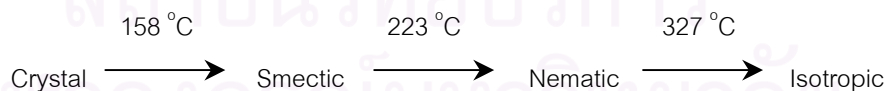

3.3.8 Applications of Liquid Crystals [19]

Liquid crystal technology has had a major effect in many areas of science and engineering, as well as device technology. Applications for this special kind of material are still being discovered and continued to provide effective solutions to many different problems.

1. Liquid crystal displays (LCD) is the most common application of liquid crystal technology. This field has grown into a multi-billion dollar industry, and many significant scientific and engineering discoveries have been made.
2. Liquid crystal thermometers demonstrated earlier, chiral nematic (cholesteric) liquid crystals reflect light with a wavelength equal to the pitch. Because the pitch is dependent upon temperature, the color reflected also is dependent upon temperature. Liquid crystals make it possible to accurately gauge temperature just by looking at the color of the thermometer. By mixing different compounds, a device for practically any temperature range can be built.
3. Optical imaging is an application of liquid crystals that is only now being explored, is optical imaging and recording. In this technology, a liquid crystal cell is placed between two layers of photoconductor. Light is applied to the photoconductor, which increases the material's conductivity. This causes an electric field to develop in the liquid crystal corresponding to the intensity of the light. The electric pattern can be transmitted by an electrode, which enables the image to be recorded. This technology is still being developed and is one of the most promising areas of liquid crystal research.
4. High-strength fibers is an application of polymer liquid crystals that has been successfully developed for industry, is the area of high strength fibers. Kevlar, which is used to make such things as helmets and bullet-proof vests, is just one example of the use of polymer liquid crystals in applications calling for strong, light weight materials. Ordinary polymers have never been able to demonstrate the stiffness necessary to compete against traditional materials like steel. It has been observed that polymers with long straight chains are significantly stronger than their tangled counterparts. Main chain liquid crystal polymers are well-suited to ordering processes. For example, the polymer can be oriented in the desired liquid crystal phase and then quenched to create a highly ordered, strong solid. As these

technologies continue to develop, an increasing variety of new materials with strong and light-weight properties will become available.

- Other applications of liquid crystal have a multitude of other uses. They are used for nondestructive mechanical testing of materials under stress. This technique is also used for the visualization of RF (radio frequency) waves in wave guides. They are used in medical applications where, for example, transient pressure transmitted by a walking foot on the ground is measured. Low molar mass (LMM) liquid crystals have applications including erasable optical disks, full color "electronic slides" for computer-aided drawing (CAD), and light modulators for color electronic imaging.

3.3.9 Structural Considerations of Low Molecular Weight Liquid Crystal Systems [22]

1. Aromatic Systems

Looking back to the period before the 1970s, the great majority of liquid crystal materials were aromatic in character and of general structure

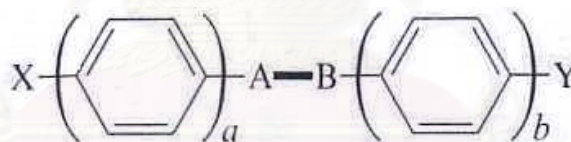

Figure 3-15 The general structure of aromatic system. [22]

- Where
- X and Y represent a range of terminal substituents such as alkyl, alkoxy and cyano.
 - A-B represents a linking unit in the core structure, e.g., -CH=N-, -N=N-, -N=NO-, -CO.O-
 - a and b have small integral values.

It was quickly realized that any substituent X or Y that does not broaden the molecule too much is superior to an H at the end of the molecule, and that groups such as cyano and alkoxy are more favorable than others such as alkyl or halogen in promoting high T_{N-I} values. At typical nematic terminal group efficiency order is $CN > OCH_3 > NO_2 > Cl > Br > N(CH_3)_2 > CH_3 > H$. The nature of the central linkage is also of great importance and linking units containing multiple bonds that

maintain the rigidity and linearity of the molecules are most satisfactory in preserving high T_{N-I} values. Thus in simply systems in figure 3-15 with a and $b = 1$, the $\text{CH}_2\text{-CH}_2$ flexible unit is a poor one and gives rise to vary weak or nonexistent nematic tendencies. The ester function contains no multiple bonds in the chain of atoms actually linking the rings, but conjugative interactions within the ester function and with the rings lead to some double bond character and a stiffer structure than might be expected. Esters are in fact fairly planar systems and quite strongly nematogenic. A typical central group nematic efficiency order is $\text{trans-CH=CH} > \text{N=NO} > \text{CH=NO} > \text{C}\equiv\text{C} > \text{N=N} > \text{CO.O} > \text{none}$.

2. Alicyclic Systems

The fairly low T_{N-I} values of the cyanobiphenyls gave little scope for structure modification by lateral substitution of the molecules, although this was possible in the case of the related terphenyl systems, used as high T_{N-I} additives.

The first major development of the biphenyl class of mesogen came therefore with the preparation of the cyclohexane analogs of structure in figure 3-16 where a may be 1 in the cyclohexane ring compounds.

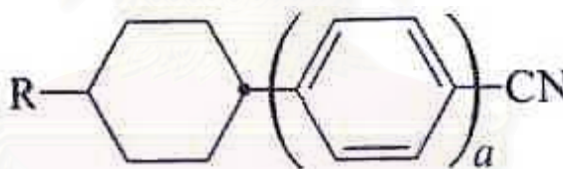

Figure 3-16 The general structure of alicyclic system. [22]

However, the cyclohexane ring compounds also had higher T_{N-I} values than the biphenyl analogs, e.g., $\text{R}=\text{C}_5\text{H}_{11}$ have T_{N-I} values of biphenyl 35°C but T_{N-I} values of cyclohexane ring 55°C . This disadvantageous effect of the cyclohexane ring at high temperatures may be due to the flexibility of the ring and its ability to adopt skewed or twisted conformations that are higher in energy and less conducive to nematic order. With regard to polymers, the advantages or disadvantages of using cyclohexane ring would also depend on T_{N-I} values. However, there are other features of using cyclohexane rings that may be important. The viscosity of low molecular weight liquid crystal systems is lowered e.g., in cyanobiphenyl analogs that $\text{R}=\text{C}_5\text{H}_{11}$ the viscosity at 20°C in nematic phase 32 cP but in cyclohexane rings analogs have the viscosity at 20°C in nematic phase 21 cP.

3. Cholesteric Systems

Since the cholesteric phase is a spontaneously twisted analog of the nematic phase, it is not surprising that molecular structural changes affect the transition temperatures of cholesteric and nematic phases in the same way. Consequently, the above generalizations about structure change in relation to T_{N-I} values apply to T_{Ch-I} values.

Only the pitch of the twist and its sense need therefore be considered additionally. Twist sense is very sensitive to structure change and for cholesterogens derived from sterols such as cholesterol. However, for commercially useful cholesterogens we do not usually want to have the presence of a bulky and often UV-sensitive steryl skeleton, and most of the important low molecular weight materials are simply chiral analogs of nematogens, the chirality being introduced by having a chiral centre in a terminally situated alkyl or alkoxy group.

Turning therefore to twisting power, this decreases as the chiral center is moved away from the ring system, i.e., as n is increased in a structure such as figure 3-17. Practically speaking, the best value of n to use is 1. This achieves a good tightness of the pitch without involving the very great reduction in T_{N-I} values that arises with $n=0$.

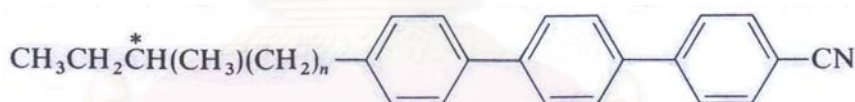

Figure 3-17 The structure of cholesteric system. [22]

4. Smectic Systems

In low molecular weight liquid crystal systems of commercial interest one usually wished to avoid smectic properties. This is not always the case, however, for latent smectic properties can be valuable for increasing the sensitivity of the color response of cholesteric phase to temperature.

Although correlated smectic phases can be envisaged for liquid crystal main chain polymers, these structures would be so akin to solids that it is doubtful, if like correlated low molecular weight smectics, these would be of commercial interest. With liquid crystal side chain polymers it is hard to envisage long range correlation of the smectic ordering of the side chain groups that would not be interfered with by the polymer backbone.

5. Diskogens

Diskogens has centered recently around compounds consisting of flat, disk-shaped molecules that can pack together to form flexible columns. These columns then constitute a diskotic liquid crystal phase, quite distinct from smectic or nematic liquid crystal phases, and having a negative sign of the optic axis.

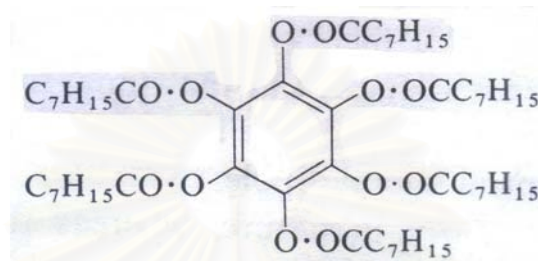

Figure 3-18 The structure of diskogens system. [22]

The relevance of such diskotic phases to polymer systems, liquid crystal main chain, or liquid crystal side chain polymers is hard to judge. Presumably a fairly straight polymer backbone with a sufficient density of lateral functions radiating outward could constitute a columnar structure, but whether this approximates closely enough to a stacking of individual disk-shaped molecules can not easily be judged.

3.4 Polymer Processing [23]

Torque rheometers with miniaturized internal mixers are multipurpose instruments that are well suited for formulating multicomponent polymer systems, and studying flow behavior, thermal sensitivity, shear sensitivity, batch compounding, etc. The instrument is applicable to thermoplastics, rubber, thermoset materials, and also to liquid materials.

The rheometer with a single screw extruder allows the measurement of rheological properties and extrusion processing characteristics to differentiate lot-to-lot variance of the materials. The rheometer also enables the process engineer to simulate a production line in the laboratory and to develop processing guidelines. Because all the measurements can be made by simulating production, it is much easier to solve problems that the engineer may face.

The torque rheometer with a twin screw extruder is considered a scaled down continuous compounder. It allows the compounding engineer to develop polymer compounds and alloys. It also permits the formulation engineer to ensure the formulation is the optimum.

Because the instruments are very versatile, low viscosity and high viscosity materials, high temperature engineering thermoplastics, rubber, and thermoset materials can be tested. Therefore, they are widely used in studying formulations, developing compounds, and characterizing the polymer flow behavior by measuring viscosity related torque caused by the resistance of the material to the shearing action of the plasticating process.

Torque is the effectiveness of a force to produce rotation. It is defined as the product of the force and the perpendicular distance from its line of action to the instantaneous center of rotation.

3.4.1 Miniaturized Internal Mixer

Most polymeric products are not pure polymers, but mixtures of the basic polymer with a variety of additives, such as pigments, lubricants, stabilizers, antioxidants, flame retardant, antiblock agents, cross-linking agents, fillers, reinforcement agents, plasticizers, UV absorbents and foaming agents. All these additives must be incorporated into the polymer prior to fabrication. Some of the additives take a significant portion of the mixture; others only minute amounts. Some are compatible; others are not.

Depending on the quality of resin and additives and homogenization of the mixtures, the quality of the final product will be varied. Therefore, developing a quality resin and additives when met with desired physical and mechanical properties of the product and quality control associated with them plays an important role in the plastic and rubber industries.

The mixer consists of a mixing chamber shaped like a figure eight, with a spiral lobed rotor in each chamber. A totally enclosed mixing chamber contains two fluted mixing rotors that revolve in opposite directions and at different speeds to achieve a shear action similar to a two-roll mill.

In the chamber, the rotors rotate in order to effect a shearing action on the material mostly by shearing the material repeatedly against the walls of the mixing chamber. The rotors have chevrons (helical projections), which perform additional mixing functions by churning the material

and moving it back and forth through the mixing chamber. The mixture is fed to the mixing chamber through a vertical chute with a ram. The lower face of the ram is part of the mixing chamber.

There is a small clearance between the rotors, which usually rotate at different speeds at the chamber wall. In these clearances, dispersive mixing takes place. The shape of the rotors and the motion of the ram during operation ensure that all particles undergo high intensive shearing flow in the clearances.

Normally, roller rotors are used for thermoplastics and thermosets, cam rotors for rubber and elastomers, and sigma rotors for liquid materials. Banbury rotors are used with a miniaturized banbury mixer for rubber compounding and formulation. Figure 3- 19 provides a schematic diagram of the miniaturized internal mixer.

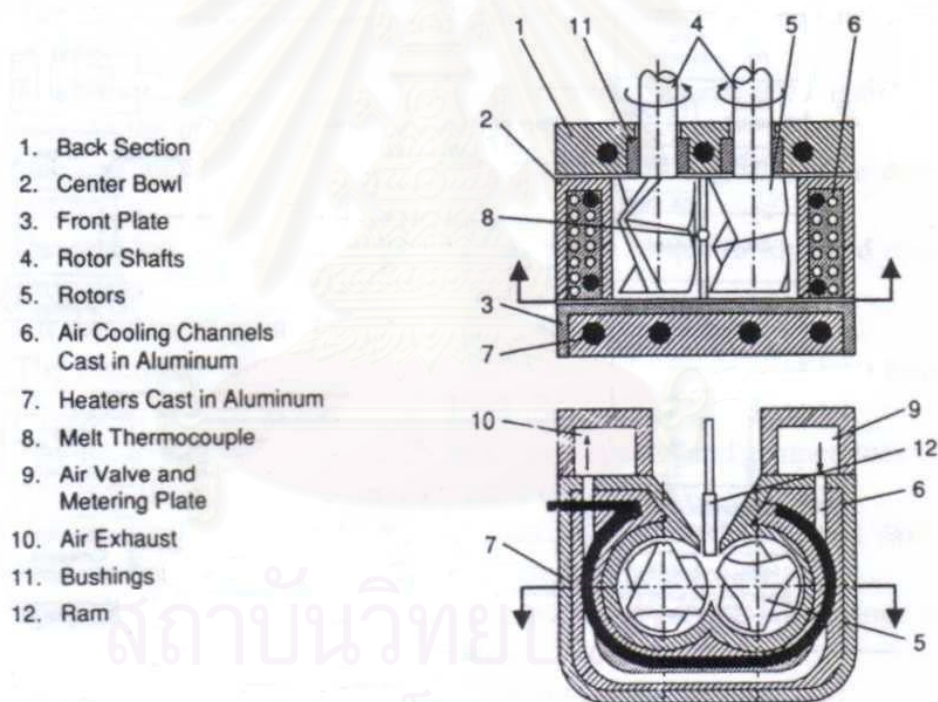

Figure 3- 19 Schematic diagram of the miniaturized internal mixer. [23]

The mixer consists of three sections, and each section is heated and controlled by its own heater and temperature controller. It is designed to maintain very accurate and uniform temperature profiles throughout the mixer.

Since mechanical dissipation heat is developed in the small gap between rotors and chamber, the heat conducts to the center bowl and raises the set temperature. In this case, the heater at the center bowl is automatically shut off, and the cooling solenoid valve is automatically energized to circulate cold air through the center section; the heaters in the back and front sections remain energized to maintain their own set temperature through the test.

The loading chute is also designed for quick loading, and the chute can be removed from the mixer after the material is fed into the mixer. If the cold chute is not removed, the chute will draw the heat out of the mixer and the set temperature will be disturbed. This will not allow the measurement of flow behavior at the desired temperature. Additionally, if the chute can not be removed after loading, the chute will be hot; it will cause problems in loading for the test to follow.

3.4.2 Single Screw Extrusion

Solids conveying, melting, mixing, and pumping are the major functions of polymer processing extruders. The single screw extruder is the machine most widely used to perform these functions.

The plasticating extruder has three distinct regions: solids-conveying zone, transition (melting) zone, and pumping zone, show in figure 3-20. It is fed by polymer in the particulate solids form. The solids, usually in pellet or powder form, in the hopper flow by gravity into the screw channel where they are conveyed through the solids-conveying section. They are compressed by drag-induced mechanism, then melted by a drag-induced melt removal mechanism in the transition section. In order words, melting is accomplished by heat transfer from the heated barrel surface and by mechanical shear heating.

สถาบันวิทยบริการ
จุฬาลงกรณ์มหาวิทยาลัย

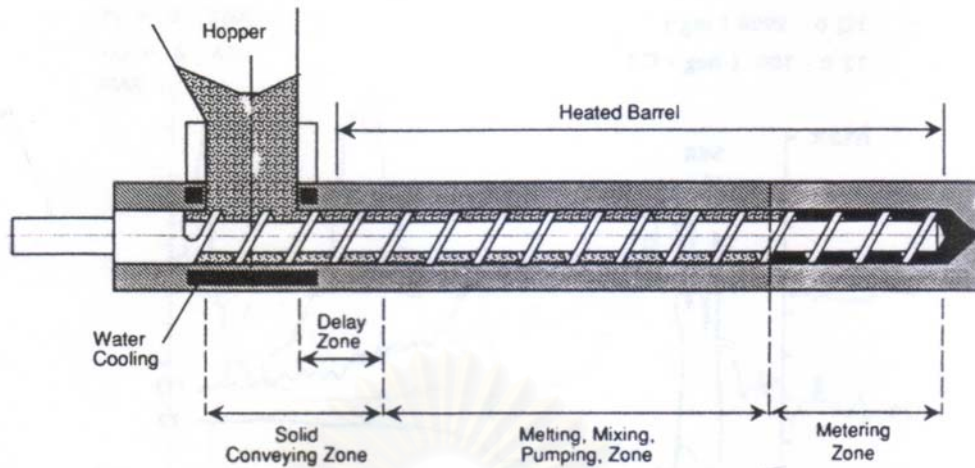

Figure 3-20 Schematic of single screw extruder. [23]

Mixing can be carried out either in a solid or in a molten state, and is achieved through the application of shear to the material. Pumping forces the molten polymer through a die to shape the commercial product or for further processing.

Solid conveying is one of the basic functions in the screw extruder. The polymer particles in the solids conveying zone exert an increasing force on each other as the material moves forward, and voids between the pellets are gradually reduced. As the particles move toward the transition section, they are packed closely together to reach a void free state, and form a solid bed, which slides along the helical channels.

The solid conveying mechanism is based on the internal resistance of a solid body sliding over another generated between the plug and barrel surface and the screw. This type of flow is known as a drag-induced plug flow. The frictional force between the barrel surface and the solid plug is the driving force for the movement of the plug; the forces between the screw and the plug retard the motion of the plug in the forward direction.

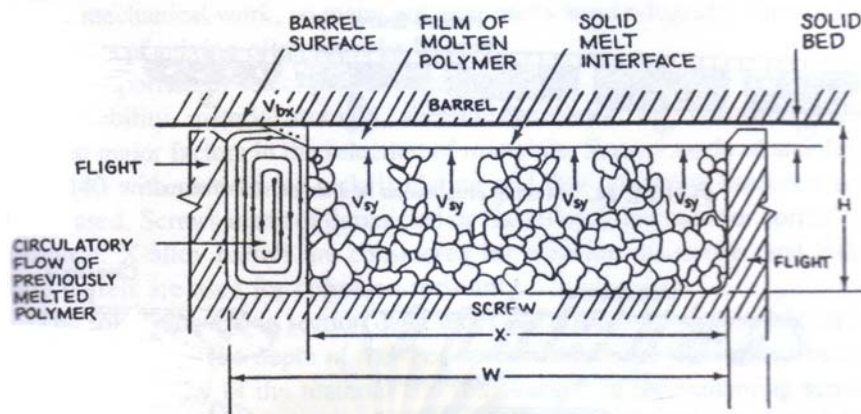

Figure 3-21 The melting mechanism of polymer in a single screw extruder. [23]

Figure 3-21 illustrates the melting mechanism of material in the extruder. Melting occurs due to mechanical and thermal energy transformed into heat. The plug formed in the solids conveying zone generates friction in contact with the heated barrel surface, and in contact with the screw. Both of these frictional processes result in frictional heat generation that raises the material temperature; this in turn exceeds the melting temperature or softening point of the polymer, and will convert the friction drag into a viscous drag mechanism. A melt film created between the hot metal and solid bed.

As the plug moves forward, the melt portion increases and forms a melt pool, which becomes larger and larger. The conveying mechanism in this zone is one of viscous drag at the barrel surface, determined by the shear stresses in the melt film and frictional drag on the rest of the screw and the flights.

Solid and molten materials coexist in the melting zone of the extruder. Figure 3-22 illustrates the melting procedure in the single screw extruders. In this figure, the sequence of events is

1. Solids conveying section (delay zone)
2. Beginning of the transition (formation of melt film)
3. Formation of melt pool
4. Melting continues and the width of the solid bed decreases, as the channel depth continues to decrease as it progresses down the transition.
5. The solid bed break up
6. The plastic continues down the metering section to the discharge.

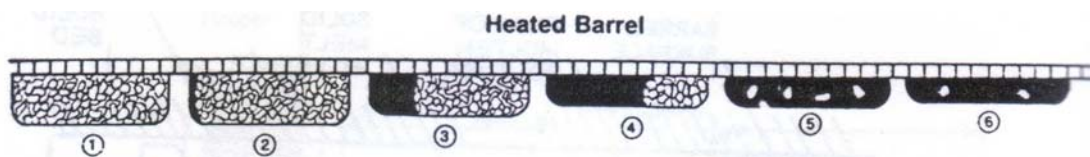

Figure 3-22 Melting progression in a single screw extruder. [23]

Melt conveying occurs in two distinctive regions. One region is downstream of the melting zone and the other is in the melt pool, which is an extension of the solid bed profile. In the metering section or at the end of the screw, the polymer transforms totally into melted polymer comes out of the extruder and die.

3.4.3 Twin Screw Extrusion

Although a single screw plasticating extruder is satisfactory for melting and extrusion, its mixing capabilities are limited. Tougher, specialized thermoplastic materials developed for new applications must be processed at conditions requiring very accurate temperature control, uniform residence time distribution, better dispersion of fillers and additives, positive venting and surge free extrusion of homogeneous melt for high quality products. Twin screw extruders are widely used for such applications and they overcome limitations of the single screw extruder and the intensive batch mixer. The twin screw unit comes in a variety of configurations they can be non partially or fully intermeshing, they are be conical or cylindrical.

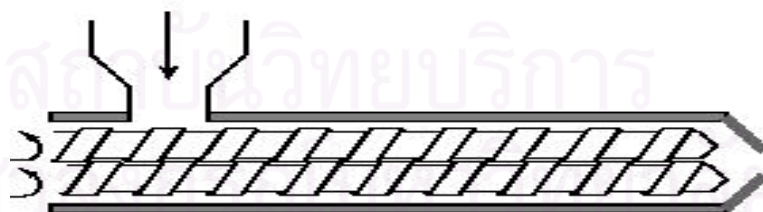

Figure 3-23 Schematic of twin screw extruder. [23]

Polymer enters the screw in the intake zone and is compressed and conveyed toward the downstream into the melting zone, where transition from solids to melt occurs. Meanwhile, at the edge of the solids bed, a melt pool is created that draw in solid particles and softens them, and the

plasticated mass is taken in by a calender gap. In flowing unmelted polymer goes into the melt stream by kneading action in the zone in which the melting begins to accelerate the melting process.

Interaction between the chambers generates high shear at points at which the screws intermesh, since the material encounters highest shear rates in this region of the machine. Figure 3-24 shows the different flow patterns of co-rotating and counter rotating screws. When the screws are rotating in opposite directions, material is forced and milled in the calender gap and is subjected to extremely high shear. These high shear rates contribute to dispersive mixing.

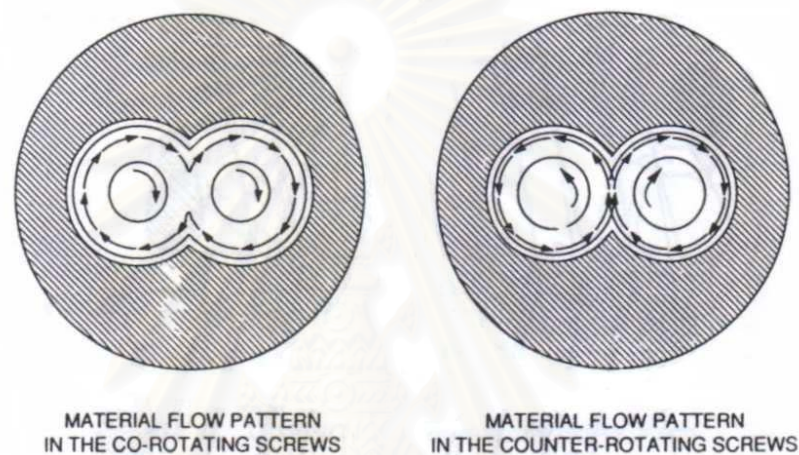

Figure 3-24 Chamber-to-chamber material flow pattern in co-rotating and counter rotating twin screws. [23]

3.4.4 Injection Molding [24]

For thermoplastics, the injection molding machine converts granular or pelleted raw plastic into final molded parts via a melt, inject, pack and cool cycle. A typical injection molding machine consists of the following major components, as illustrated in figure 3-25.

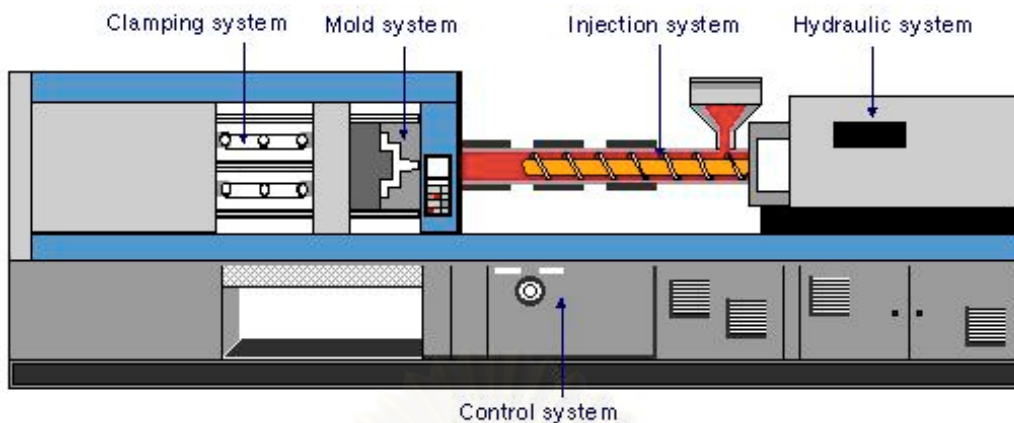

Figure 3-25 A single screw injection molding machine for thermoplastics. [24]

1. Injection system

The injection system consists of a hopper, a reciprocating screw and barrel assembly, and an injection nozzle, as show in figure 3-26. This system confines and transports the plastic as it progresses through the feeding, compressing, degassing, melting, injection, and packing stages.

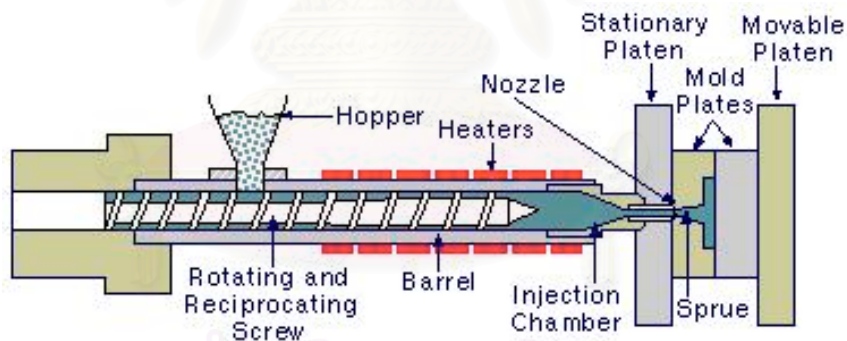

Figure 3-26 A single screw injection molding machine for thermoplastics, showing the plasticizing screw, a barrel, band heaters to heat the barrel, a stationary platen, and a movable platen. [24]

The hopper on the injection molding machine holds the pellets. The pellets are gravity fed from the hopper through the hopper throat into the barrel and screw assembly. The barrel of the injection molding machine supports the reciprocating plasticizing screw. It is heated by the electric heater bands. The reciprocating screw is used to compress, melt and convey the material. The reciprocating screw consist of three zones, the feeding zone, the compressing or transition zone and the metering zone. While the outside diameter of the screw remain constant, the depth of the flights on the reciprocating screw decreases from the feed zone to the beginning of the metering zone.

These flights compress the material against the inside diameter of the barrel, which creates viscous (shear) heat. This shear heat is mainly responsible for melting the material. The heater bands outside the barrel help maintain the material in the molten state. Typically, a molding machine can have three or more heater bands or zones with different temperature settings.

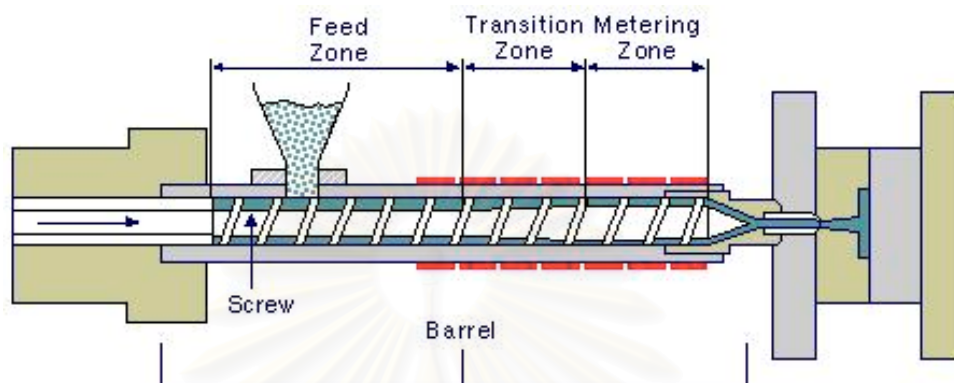

Figure 3-27 A reciprocating screw, showing the feeding zone, compressing zone and metering zone.

[24]

The nozzle connects the barrel to the sprue bushing of the mold and forms a seal between the barrel and the mold. The temperature of the nozzle should be set to the material's melt temperature or just below it, depending on the recommendation of the material supplier. When the barrel is in its full forward processing position, the radius of the nozzle should nest and seal in the concave radius in the sprue bushing with a locating ring. During purging of the barrel, the barrel backs out from the sprue, so the purging compound can free fall from the nozzle. These two barrel positions are illustrated below.

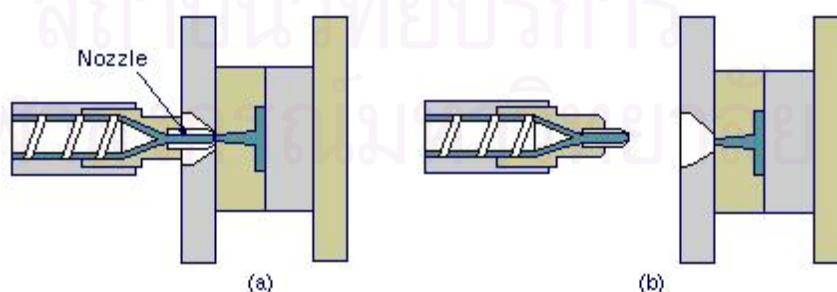

Figure 3-28 (a) Nozzle with barrel in processing position. (b) Nozzle with barrel backed out for purging. [24]

2. Mold system

The mold system consists of the bars, stationary and moving platens, as well as molding plates that house the cavity, sprue and runner systems, ejector pins, and cooling channels, as shown as in figure 3-29. The mold is essentially a heat exchanger in which the molten thermoplastic solidifies to the desired shape and dimensional details defined by the cavity.

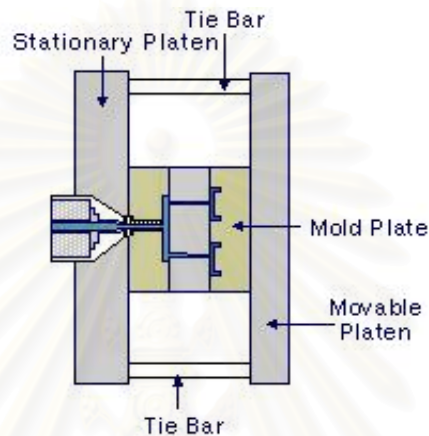

Figure 3-29 A typical (three-plate) molding system. [24]

A mold system is an assembly of platens and molding plates typically made of tool steel. The mold system shapes the plastics inside the mold cavity and ejects the molded part. The stationary platen is attached to the barrel side of the machine and is connected to the moving platen by the tie bars. The cavity plate is generally mounted on the stationary platen and houses the injection nozzle. The core plate moves with the moving platen guided by the tie bars. Occasionally, the cavity plate is mounted to the moving platen and the core plate and a hydraulic knockout (ejector) system is mounted to the stationary platen.

The two-plate mold is the vast majority of molds consist essentially of two halves. This kind of mold is used for parts that are typically gated on or around their edge, with the runner in the same mold plate as the cavity.

The three-plate mold is typically used for parts that are gated away from their edge. The runner is in two plates, separate from the cavity and core, as shown in figure 3-30.

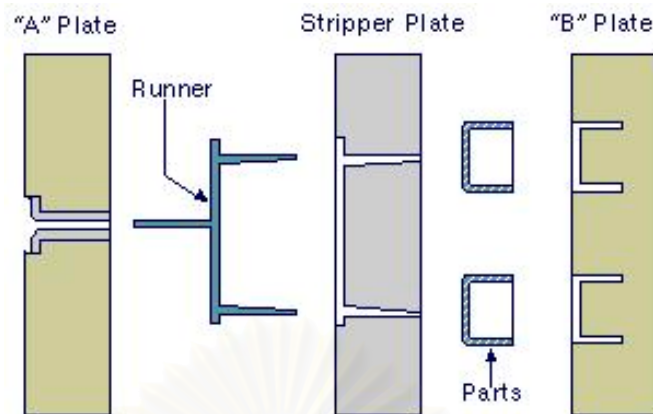

Figure 3-30 A three-plate mold. [24]

The cooling channels or circuits are passageways located within the body of a mold, through which a cooling medium (typically water, steam, or oil) circulates. Their function is the regulation of temperature on the mold surface. Cooling channels can also be combined with other temperature control devices, like bafflers, and thermal pins or heat pipes.

A typical molded system consists of the delivery system and the molded part, as shown in figure 3-31. The delivery system which provides passage for the molten plastic from the machine nozzle to the part cavity, generally includes; a sprue, cold slug wells, a main runner, branch runners and gates.

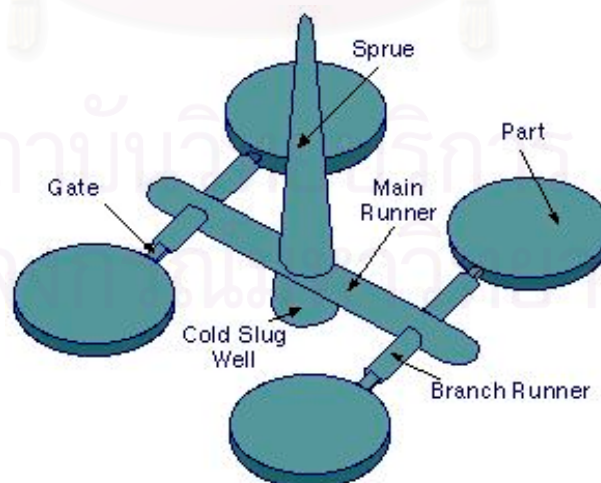

Figure 3-31 The molded system includes a delivery system and molded parts. [24]

The delivery system design has a great influence on the filling pattern and thus the quality of the molded part. The cold runner delivery system is trimmed off and recycled. Therefore the delivery system is normally designed to consume minimum material, while maintaining the function of delivering molten plastic to the cavity in a desirable pattern. The hot runner molding process keeps the runners hot in order to maintain the plastic in a molten state at all times. Since the hot runner system is not removed from the mold with the molded part, it saves material and eliminates the secondary trimming process.

3. Hydraulic system

The hydraulic system on the injection molding machine provides the power to open and close the mold, build and hold the clamping tonnage, turn the reciprocating screw, drive the reciprocating screw, and energize ejector pins and moving mold cores. A number of hydraulic components are required to provide this power, which include pumps, valves, hydraulic motors, hydraulic fittings, hydraulic tubing and hydraulic reservoirs.

4. Control system

The control system provides consistency and repeatability in machine operation. It monitors and controls the processing parameters, including the temperature, pressure, injection speed, screw speed and position, and hydraulic position. The process control has a direct impact on the final part quality and the economics of the process. Process control systems can range from a simple relay on/off control to an extremely sophisticated microprocessor-based, closed-loop control.

5. Clamping system

The clamping system opens and closes the mold, supports and carries the constituent parts of the mold, and generates sufficient force to prevent the mold from opening. Clamping force can be generated by a mechanical (toggle) lock, hydraulic lock, or a combination of the two basic types.

CHAPTER 4

EXPERIMENTS

In this chapter, materials, equipments, sample preparations and procedures of the experiments will be explained.

4.1 Materials

4.1.1 Poly (bisphenol A carbonate), PC

Poly (bisphenol A carbonate) is an amorphous engineering thermoplastic. Polycarbonate is a member of the polyester family; it contains carbon and oxygen atoms as the backbones of the molecular chain.

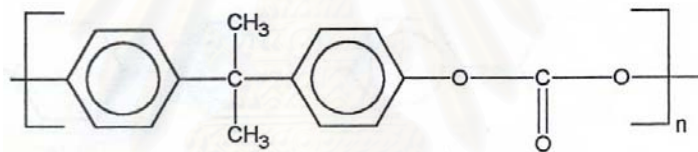

Figure 4-1 The structure of poly (bisphenol A carbonate). [2]

This polymer is a water-clear material, easily colored and is adaptable to a variety of molding processes including the injection, extrusion, and blow molding. Polycarbonate has high impact strength, heat resistance, dimensional stability, good weatherability and good chemical resistance. The applications of polycarbonate are in electronic and telecommunication equipment, food appliances and services, safety equipment and medical device, etc.

In this research, Bayer Polymers Company Limited provided commercial grade polycarbonate having a trade name of "MAKROLON". There were two different molecular weights of polycarbonates used in this work. The melt flow indexes are 19.88 g/10 min and 23.14 g/10 min at 300°C/2.16 kg. The average molecular weights are 43,493 g/mol and 35,806 g/mol. They are noted as PC2600 and PC2405 respectively. The appearances of these polycarbonates are transparent pellets. The glass transition temperature is around 150 °C.

4.1.2 High Density Polyethylene, HDPE

Polyethylene (PE) [26] is the largest volume usage of plastics, which are produced from ethylene (see in figure 4-2). HDPE belongs to PE group, which is a thermoplastic material in the form of solid at room temperature. Under the extrusion conditions with heat, pressure, and mechanical shear, it softens into a highly viscous, molten mass under the solidified conditions in the shape of the desired end product, such as film, pipes or drum. The HDPE is characterized by its opacity, chemical inertness, and toughness at both low and high temperature as well as chemical resistance, moisture barrier and electrical insulating properties.

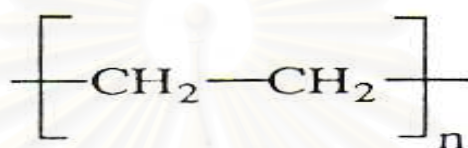

Figure 4-2 The structure of polyethylene. [2]

In this research, Thai Petrochemical Industry Public Company Limited provided commercial grade of HDPE. The melt flow index is 3 g/10 min at 300 °C/2.16 kg and the crystalline melting temperature about 200 °C

4.1.3 Liquid Crystal

Low molecular weight thermotropic liquid crystal was used in this work. Merck Company Limited manufactures it, under the trade name of "LICRISTAL". Selected liquid crystal materials include cyclohexylbiphenylcyclohexane (CBC-33) and biphenylcyclohexane (BCH-5). In this study, CBC-33 was blended with polycarbonates and BCH-5 was blended with high density polyethylene.

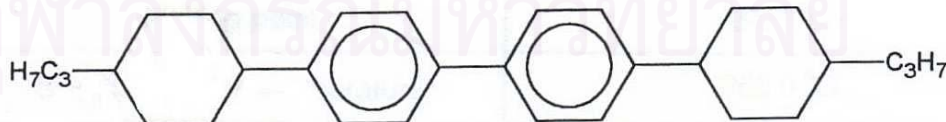

Figure 4-3 The structure of CBC-33. [25]

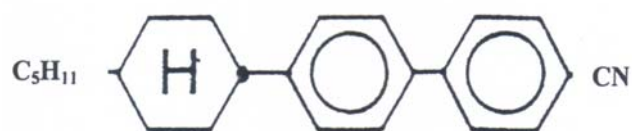

Figure 4-4 The structure of BCH-5. [25]

Table 4-1 Properties of CBC-33. [25]

Melting point	158 °C
S-N transition temperature	223 °C
Clearing point	327 °C
Melting enthalpy	13 kJ/mol
Molecular weight	402.67 g/mol

Table 4-2 Properties of BCH-5. [25]

Melting point	96 °C
Clearing point	219.3 °C
Melting enthalpy	19.7 kJ/mol
Molecular weight	331.51 g/mol

สถาบันวิทยบริการ
จุฬาลงกรณ์มหาวิทยาลัย

4.2 Equipments

4.2.1 Digital Hot Plate Stirrer

A Cole-Parmer digital hot plate stirrer was used in this study for preparing the samples between the polymers and low molecular weight liquid crystal. This programmable hot plate stirrer has all functions that can be set from the digital panel and display their status on LCD. The plate temperature, stir speed and time of heating are controllable. It belongs to Polymer Engineering Laboratory, the Department of Chemical Engineering, Chulalongkorn University.

4.2.2 Hydraulic Hot Press

A local made hydraulic hot press was used in these experiments. The maximum operating temperature of this machine is 600 °C and the maximum pressure is 5,000 psi. This equipment is used to prepare the samples in this research. It belongs to Polymer Engineering Laboratory, the Department of Chemical Engineering, Chulalongkorn University.

4.2.3 Internal Mixer

A Haake torque rheometer model R3000p was utilized to investigate the torque of the internal mixer used when melting the polymers. The maximum operating temperature is 450 °C, maximum torque is 300 Nm and maximum volume of mixing chamber is 315 cm³. The temperature, rotor speed and other conditions could be directly controlled by computerized system. It belongs to National Metal and Materials Technology Center.

4.2.4 Single Screw Extruder

A Haake single screw extruder model Rheocord R252 was used for blending polycarbonate with LCC and to investigate the operating torque during extruding the polymers. Screw diameter is 19.05 mm with L/D of 25:1, compression ratio is 3:1. Die type is rod die with a die diameter of 3 mm. The maximum operating temperature is 480 °C, maximum torque is 160 Nm, maximum pressure is 500 bar and maximum capacity is 30 kg/h. The temperatures, screw speed and other conditions could be directly controlled by computerized system. It belongs to National Metal and Materials Technology Center.

4.2.5 Twin Screw Extruder

A Haake twin screw extruder model Rheomex CTW100p was used for blending polycarbonate with LCC and to investigate the operating torque during extruding the polymers. This extruder is a counter rotating type with three heating zones. Screw diameter is 20 mm with L/D of 15:1. Die type is multistrand die with a die diameter of 3 mm. The maximum operating temperature is 480 °C, maximum torque is 200 Nm and maximum pressure is 700 bar. The temperatures, screw speed and other conditions could be directly controlled by computerized system. It belongs to Department of Tool and Materials Engineering, King Mongkut's University of Technology Thonburi.

4.2.6 Injection Molding Machine

A BOY injection molding machine model 22M was utilized to prepare the tensile testing specimens (dumbbell shape). This machine has a single screw with four heating zones. Screw diameter is 24 mm with L/D of 17:1, and the maximum clamping force is 220 kN. All functions can be set from digital panel; operating status can be displayed on the monitor. It belongs to Institute of Technological Development for Industry, King Mongkut's Institute of Technology North Bangkok.

4.2.7 Tensile Testing Machine

Tensile tests were performed using LLOYD tensile testing machine model 2000R. Resulted obtained are the stress-strain behaviors of polymers and their blends. The test procedure is modified in accordance with ASTM D638 covering determination of basic tensile properties of plastics.

The force necessary to elongate and break that specimen was measured by load cell in the machine. The stress occurred at the break was designated as the tensile stress at break. The average tensile value of 6 specimens was used. In this study, the cross head speed was set at constant rate of 50 mm/min. Load cell used is 1,000 N. It belongs to Polymer Engineering Laboratory, the Department of Chemical Engineering, Chulalongkorn University.

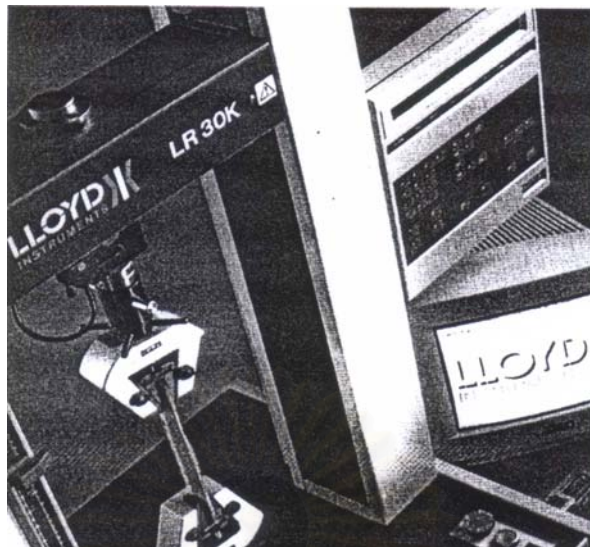

Figure 4-5 Tensile testing machine. [4]

4.2.8 Differential Scanning Calorimetry (DSC)

The glass transition temperatures of samples before and after prepared by the twin screw extruder were analyzed using NETZSCH thermal analyzer model DSC200 to determine. In this study, the heating rate was set at 10 °C/min from room temperature to 200 °C and liquid nitrogen was used to quench the sample with quenching rate 20 °C/min to room temperature. DSC belongs to Scientific and Technological Research Equipment Center, Chulalongkorn University.

4.2.9 Gel Permeation Chromatography (GPC)

A Water 150-CV gel permeation chromatography was used to determine the molecular weight distribution of samples before and after prepared by the internal mixer. The samples were dissolved in tetrahydrofuran (THF); prepared solutions had concentration about 0.03% weight per volume. GPC belongs to National Metal and Materials Technology Center.

4.2.10 Scanning Electron Microscopy (SEM)

A JEOL scanning electron microscope model JSM-5410LV was used to observe morphology of fracture surface of pure polycarbonates and their blends with LCC after blending by the internal mixer, single screw extruder and twin screw extruder. The blend extrudate rods were cryogenically fractured in liquid nitrogen in order to reveal the geometry. A thin layer of gold was coated on the

specimens before viewing. SEM belongs to Scientific and Technological Research Equipment Center, Chulalongkorn University.

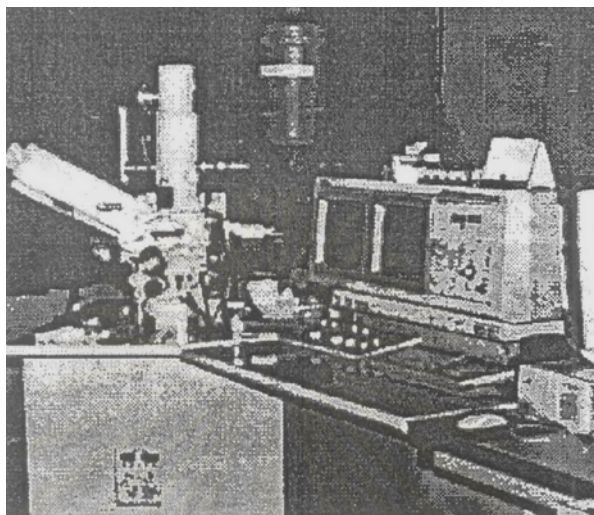
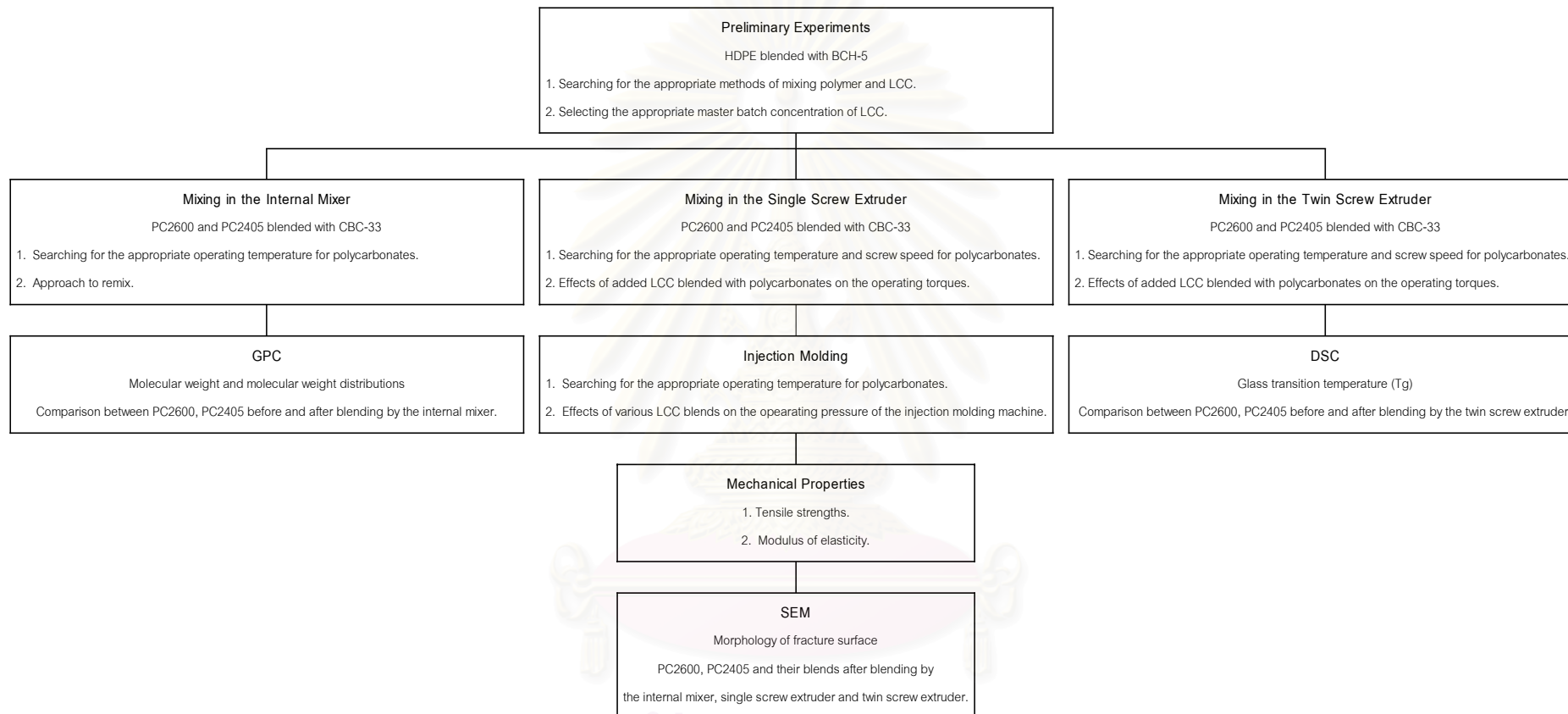

Figure 4-6 Scanning electron microscope. [24]

สถาบันวิทยบริการ
จุฬาลงกรณ์มหาวิทยาลัย



สถาบันวิทยบริการ
จุฬาลงกรณ์มหาวิทยาลัย

Figure 4-7 Chart of all methods of experiments.

4.3 Searching for the Appropriate Methods of Mixing Polymer and Low Molecular Weight Liquid Crystal Using the Internal Mixer

4.3.1 Preparation of Master Batch (Concentration of 10% by weight BCH-5)

The blends between high-density polyethylene (HDPE) and low molecular weight liquid crystal (BCH-5) were prepared using a digital hot plate stirrer. HDPE was weighed about 5 g and BCH-5 was weighed about 0.5 g; they were laid on a teflon-coated plate and placed on the digital hot plate stirrer. The hot plate was set at 200 °C. HDPE and BCH-5 were melted and mixed together for 15 minutes by mechanical stirring in order to have uniform mixtures. After that, the blends were put between the heat resistance film (kapton film) and then compressed for 2 minutes by the hydraulic hot press at 200 °C and 250 kg/cm³. The resulted blends in the thin film shape were cooled by air and cut to pieces after removed from the mold.

4.3.2 Method of Experiment

The operating conditions of the internal mixer were controlled at the temperature of 180 °C, rotor speed of 40 rpm. The pure HDPE was fed into the mixing chamber through a vertical chute. Then, the mixing chamber was closed by lower down the ram to push the pellet into the chamber and the mixer was operated for 30 minutes. After finished, the melted polymer was removed and the mixing chamber and rotors were cleaned. After that, the pure HDPE was fed into the mixing chamber and the mixer was operated for 10 minutes, followed by adding the BCH-5 about 0.1% by weight. After 10 minutes mixing, 0.1% by weight of BCH-5 was added into the mixing chamber again to obtain the total mixture of 0.2% by weight inside the chamber and the mixer was further operated for 10 minutes. After finished, the blend was removed and the mixing chamber and rotors were cleaned. Next, dried pure HDPE and BCH-5 0.2 % by weight were mixed in a plastic bag before feeding into the mixing chamber. After mixed, the dry blend was fed into the mixing chamber and the mixer was operated for 30 minutes. After finished, the blend was removed and the mixing chamber and rotors were cleaned. Finally, the pure HDPE and the master batch of BCH-5 prepared by the method described above having a concentration about 10% by weight were mixed as pellets in the plastic bag. The resulted blend has the total concentration of BCH-5 about 0.2% by weight. After that, the blend was fed into the mixing chamber and the mixer was operated for 30 minutes. After finished, the blend was removed and the mixing chamber and rotors were cleaned.

4.4 Using the Internal Mixing Machine Performances to Select the Appropriate Concentration of Low Molecular Weight Liquid Crystal and Rotors Speed

4.4.1 Preparation of Master Batch (Concentration of 1.1, 2.2, 4.4, 8.8 % by weight BCH-5)

The blends between HDPE and BCH-5 were prepared using the digital hot plate stirrer at amount of 40, 20, 10 and 5 g of HDPE respectively. BCH-5 was weighed about 0.44 g in all cases and mixed with HDPE as mentioned before to obtain the master batches concentration of 1.1, 2.2, 4.4 and 8.8 % by weight of BCH-5. The blends were laid on the teflon-coated plate and placed on the digital hot plate stirrer at 200 °C. Each HDPE and BCH-5 as melted and mixed together for 15 minutes by mechanical stirring in order to have uniform mixtures. After that, the blends were put between the heat resistance film (kapton film) and then compressed for 2 minutes by the hydraulic hot press at 200 °C and 250 kg/cm³. The resulted blends in the thin film shape were cooled by air and cut to pieces after removed from the mold.

4.4.2 Method of Experiment

The operating conditions of the internal mixer were controlled at the temperature of 180 °C, rotor speed of 40 rpm. The pure HDPE was fed into the mixing chamber and the mixer was operated for 15 minutes. After that the rotor speed was decreased to 10 rpm for 5 minutes. The rotor speed was further increased to 20, 40 and 80 rpm, respectively and the mixer was operated in the same method as described above. After finished, the melted polymer was removed and the mixing chamber and rotors were cleaned.

The pure HDPE and master batch of BCH-5 prepared by the method described above having a concentration about 1.1% by weight were mixed as pellets in the plastic bag. The resulted blend has the total concentration of BCH-5 about 0.2% by weight. After that, the blend was fed into the mixing chamber and the mixer was operated in the same method as described above. Next, the concentration of master batch was changed from 1.1% by weight to 2.2, 4.4, 8.8 % by weight respectively and the mixer was operated in the same method as described above.

4.5 Searching for the Appropriate Operating Temperature of Polycarbonate Using the Internal Mixer

4.5.1 Method of Determining the Appropriate Operating Temperature

The operating conditions of the internal mixer were controlled at the temperature of 280 °C, rotor speed of 40 rpm. The pure PC2600 was fed into the mixing chamber and the mixer was operated for 15 minutes. After finished, the melted PC2600 was removed and the mixing chamber and rotors were cleaned. After that, the operating temperature was changed from 280 °C to 270, 250, 230 and 200 °C respectively and the mixer was operated in the same method as described above.

4.6 Approach to Remix Using the Internal Mixer

In this study, the blends between two different polycarbonates were mixed with low molecular weight liquid crystal (CBC-33). The first blend used polycarbonate having the melt flow index of 19.88 g/10 min at 300 °C/2.16 kg and the average molecular weight of 43,493 g/mol, noted as PC2600. The second blend contained polycarbonate having the melt flow index of 23.14 g/10 min at 300 °C/2.16 kg and the average molecular weight of 35,806 g/mol, noted as PC2405.

4.6.1 Preparation of Master Batch (Concentration of 8.8% by weight CBC-33)

The blends between PC2600 and LCC (CBC-33) were prepared using the digital hot plate stirrer. PC2600 was weighed about 5 g and CBC-33 was weighed about 0.44 g; they were laid on the teflon-coated plate and placed on the digital hot plate stirrer. The hot plate was set at 290 °C. PC2600 and CBC-33 were melted and mixed together for 15 minutes by mechanical stirring in order to have uniform mixtures. After that, the blends were put between the heat resistance film (kapton film) and then compressed for 2 minutes by the hydraulic hot press at 290 °C and 250 kg/cm³. The resulted blends in the thin film shape were cooled by air and cut to pieces after removed from the mold. The PC2405, which is the different type of polycarbonate, was applied instead of PC2600 and the experimental methods were repeated to get the master batch of CBC-33 for PC2405.

4.6.2 Preparation of PC2600 remix and PC2405 remix

The blends between PC2600 and CBC-33 were prepared using the digital hot plate stirrer. PC2600 was weighed about 20 g and CBC-33 was weighed about 0.04 g; they were laid on the teflon-coated plate and placed on the digital hot plate stirrer. The hot plate was set at 290 °C. PC2600 and CBC-33 were melted and mixed together for 15 minutes by mechanical stirring in order to have uniform mixtures. After that, the blends were put between the heat resistance film (kapton film) and then compressed for 2 minutes by the hydraulic hot press at 290 °C and 250 kg/cm³. The resulted blends in the thin film shape were cooled by air and cut to pieces. The mixing was repeated in the same method as above for 11 times to get the sample of PC2600 remix. The PC2405, which is the different type of polycarbonate, was applied instead of PC2600 and the experimental methods were repeated to get the sample of PC2405 remix.

4.6.3 Method of Experiment

The operating conditions of the internal mixer were controlled at the temperature of 200 °C, rotor speed of 40 rpm. The pure PC2600 was fed into the mixing chamber and the mixer was operated for 12 minutes. After finished, the melted polymer was removed and the mixing chamber and rotors were cleaned. After that, the pure PC2600 and the master batch of CBC-33 prepared by the method described above having a concentration about 8.8% by weight were mixed as pellets in the plastic bag. The resulted blend has the total concentration of CBC-33 about 0.2% by weight. After that, the blend was fed into the mixing chamber and the mixer was operated in the same method as described above. Finally, the PC2600 remix was fed into the mixing chamber and the mixer was operated in the same method as described above. The PC2405, which is the different type of polycarbonate, was applied instead of PC2600 and the experimental methods were repeated with the mixer was operated in the same method as mentioned before.

4.7 Methods of Experiments Using the Single Screw Extruder

4.7.1 Sample Preparation

PC2600 was vacuum dried at 120 °C for 24 hours before being used for the single screw extruder.

4.7.2 Method of Determining the Appropriate Operating Temperature

The operating temperatures of the single screw extruder were set at 200, 210, 220 °C for zone 1,2 and 3, respectively, die temperature was set at 220 °C and cooling temperature was set at 35 °C. The screw speed was set at 40 rpm. Pure PC2600 was fed into the hopper of the extruder. The extruded strand was cut into small pellets by a pelletizer with a cutting speed about 300 rpm. After that the operating temperatures were increased to 220, 230, 240 °C for zone 1,2 and 3, respectively, die temperature was set at 240 °C. The operating temperatures were further increased to 240, 250, 260 °C for zone 1,2 and 3, respectively, die temperature was set at 260 °C. Final set of experiment run at the operating temperature of 260, 270, 280 °C of zone 1,2 and 3, respectively, die temperature was set at 280 °C and the single screw extruder was operated in the same method as described above.

4.7.3 Method of Determining the Appropriate Screw Speed

The operating temperatures of the single screw extruder were set at 260, 270, 280 °C for zone 1,2 and 3, respectively, die temperature was set at 280 °C and cooling temperature was set at 35 °C. The screw speed was set at 40 rpm. Pure PC2600 was fed into the hopper of the extruder. The extruded strand was cut into small pellets by a pelletizer with a cutting speed about 300 rpm. After that the screw speed was decreased to 20 rpm and the single screw extruder was operated in the same method as described above.

4.8 Effects of Added Low Molecular Weight Liquid Crystal Blend with Polycarbonate on the Operating Torque of the Single Screw Extruder

4.8.1 Preparation of Master Batch (Concentration of 8% by weight CBC-33)

The blends between PC2600 and LCC (CBC-33) were prepared using the digital hot plate stirrer. PC2600 was weighed about 15 g and CBC-33 was weighed about 1.2 g; they were laid on the teflon-coated plate and placed on the digital hot plate stirrer. The hot plate was set at 290 °C. PC2600 and CBC-33 were melted and mixed together for 15 minutes by mechanical stirring in order to have uniform mixtures. After that, the blends were put between the heat resistance film (kapton film) and then compressed for 2 minutes by the hydraulic hot press at 290 °C and 250 kg/cm³. The resulted blends in the thin film shape were cooled by air and cut to pieces after removed from the mold. The PC2405, which is the different type of polycarbonate, was applied instead of PC2600 and the experimental methods were repeated to get the master batch of CBC-33 for PC2405.

4.8.2 Sample Preparation

The pure PC2600, PC2405 and the master batch of PC2600 and PC2405 were vacuum dried at 120 °C for 24 hours before being used for the single screw extruder.

4.8.3 Method of Experiment

The operating temperatures of the single screw extruder were set at 260, 270, 280 °C for zone 1,2 and 3, respectively, die temperature was set at 280 °C and cooling temperature was set at 35 °C. The screw speed was set at 20 rpm. Pure PC2600 was fed into the hopper of the extruder. The extruded strand was cut into small pellets by a pelletizer with a cutting speed about 300 rpm. After that, the pure PC2600 and master batch of CBC-33 prepared by the method described above having a concentration about 8% by weight were mixed as pellets in the plastic bag. The resulted blend has the total concentration of CBC-33 about 0.2% by weight. After that, the blend was fed into the extruder. After 3 minutes pass, the sample was kept. After that, a part of sample was fed back into the extruder again. After 3 minutes pass, the sample was kept; noted as PC2600 remix. When used up the blend, HDPE was fed to clean the extruder. The PC2405, which is the different type of polycarbonate, was applied instead of PC2600 and the experimental methods were repeated and the single screw extruder was operated in the same method as described above.

4.9 Methods of Experiments Using the Twin Screw Extruder

4.9.1 Sample Preparation

PC2600 was vacuum dried at 120 °C for 24 hours before being used for the twin screw extruder.

4.9.2 Method of Determining the Appropriate Operating Temperature

The operating temperatures of the twin screw extruder were set at 220, 230, 240 °C for zone 1,2 and 3, respectively, die temperature was set at 240 °C and cooling temperature was set at 33 °C. The screw speed was set at 40 rpm. Pure PC2600 was fed into the hopper of the extruder. The extruded strands were cut into small pellets by a pelletizer with a cutting speed about 7 rpm. After that the operating temperatures were increased to 240, 250, 260 °C for zone 1,2 and 3, respectively, die temperature was set at 260 °C. The operating temperature were further increased to 260, 270, 280 °C for zone 1,2 and 3, respectively, die temperature was set at 280 °C and the twin screw extruder was operated in the same method as described above.

4.9.3 Method of Determining the Appropriate Screw Speed

The operating temperatures of the twin screw extruder were set at 240, 250, 260 °C, die temperature was set at 260 °C and cooling temperature was set at 33 °C. The screw speed was set at 40 rpm. Pure PC2600 was fed into the hopper of the extruder. The extruded strands were cut into small pellets by a pelletizer with a cutting speed about 7 rpm. After that the screw speed was increased to 60 rpm and the twin screw extruder was operated in the same method as described above.

4.10 Effects of Added Low Molecular Weight Liquid Crystal Blend with Polycarbonate on the Operating Torque of the Twin Screw Extruder

4.10.1 Preparation of Master Batch (Concentration of 8% by weight CBC-33)

The blends between PC2600 and LCC (CBC-33) were prepared using the digital hot plate stirrer. PC2600 was weighed about 15 g and CBC-33 was weighed about 1.2 g; they were laid on the teflon-coated plate and placed on the digital hot plate stirrer. The hot plate was set at 290 °C. PC2600 and CBC-33 were melted and mixed together for 15 minutes by mechanical stirring in order to have uniform mixtures. After that, the blends were put between the heat resistance film (kapton film) and then compressed for 2 minutes by the hydraulic hot press at 290 °C and 250 kg/cm³. The resulted blends in the thin film shape were cooled by air and cut to pieces after removed from the mold. The PC2405, which is the different type of polycarbonate, was applied instead of PC2600 and the experimental methods were repeated with to get the master batch of CBC-33 for PC2405.

4.10.2 Sample Preparation

The pure PC2600, PC2405 and the master batch of PC2600 and PC2405 were vacuum dried at 120 °C for 24 hours before being used for the twin screw extruder.

4.10.3 Method of Experiment

The operating temperatures of the twin screw extruder were set at 240, 250, 260 °C for zone 1,2 and 3, respectively, die temperature was set at 260 °C and cooling temperature was set at 33 °C. The screw speed was set at 60 rpm. Pure PC2600 was fed into the hopper of the extruder. The extruded strands were cut into small pellets by a pelletizer with a cutting speed about 7 rpm. After that, the pure PC2600 and master batch of CBC-33 prepared by the method described above having a concentration about 8% by weight were mixed as pellets in the plastic bag. The resulted blend has the total concentration of CBC-33 about 0.2% by weight. After that, the blend was fed into the extruder. After 3 minutes pass, the sample was kept. After that, a part of sample was fed back into the extruder again. After 3 minutes pass, the sample was kept; noted as PC2600 remix. When used up the blend, HDPE was fed to clean the extruder. The PC2405, which is the different type of polycarbonate, was applied instead of PC2600 and the experimental methods were repeated. However, the operating temperatures were changed from 240, 250, 260 °C for zone 1,2 and 3, respectively, to 170, 205, 215 °C for zone 1,2 and 3, respectively. The die temperature was changed

from 260 °C to 225 °C and the twin screw extruder was operated in the same method as described above.

4.11 Methods of Experiments Using the Injection Molding Machine

4.11.1 Sample Preparation

PC2600 was vacuum dried at 120 °C for 24 hours before being used for the injection molding machine.

4.11.2 Method of Experiment

The operating temperatures of the injection molding machine were set at 260, 265, 270 and 275 °C for zone 1,2,3 and nozzle, respectively. The screw position was set at 38 mm. The pressures at injection stroke were set at 160 and 145 bar. Pure PC2600 was fed into the hopper after that the melted PC2600 was injected into the mold with 50% of speed and held in the mold at pressure of 77 bar with cooling time of 37 seconds. The sample was injected 3 specimens, after that the operating temperatures were increased to 265, 270,275 and 280 °C for zone 1,2,3 and nozzle, respectively. The operating temperatures were further increased to 270, 275,280 and 285 °C for zone 1,2,3 and nozzle, respectively. Final, set of experiment run at the operating temperatures of 275, 280,285 and 290 °C for zone 1,2,3 and nozzle, respectively and the injection molding machine was operated in the same method as described above.

สถาบันวิทยบริการ
จุฬาลงกรณ์มหาวิทยาลัย

4.12 Effects of Various Low Molecular Weight Liquid Crystal Blends on the Operating Pressures of the Injection Molding Machine

4.12.1 Sample Preparation

Vacuum dried the samples that prepared by the internal mixer, single screw extruder and twin screw extruder at 120 °C for 24 hours before being used for the injection molding machine.

4.12.2 Method of Experiment

The operating temperatures of the injection molding machine were set at 275, 280, 285 and 290 °C for zone 1, 2, 3 and nozzle, respectively. The screw position was set at 38 mm. The pressures at injection stroke were set at 160 and 145 bar. Pure PC2600 was fed into the hopper after that the melted PC2600 was injected into the mold with 50% of speed and held in the mold at pressure of 77 bar with cooling time of 37 seconds. The sample was injected for 5 specimens. After that the blend between PC2600 and CBC-33 was fed into the hopper and the injection molding machine was operated in the same method as described above. Finally, the PC2600 remix was fed into the hopper and the injection molding machine was operated in the same method as described above. The PC2405, which is the different type of polycarbonate, was applied instead of PC2600 and the experimental methods were repeated. However, the pressures at injection stroke were changed from 160 and 145 bar to 130 and 100 bar. The holding pressure was changed from 77 bar to 61 bar and the injection molding machine was operated in the same method as described above.

4.13 Tensile Testing of Samples from the Injection Molding Machine

The tensile testing conditions were chosen following ASTM D638. Dumbbells shaped samples type II were injected from the injection molding machine with the dimension shown in figure 4-8. Specimen dimensions of type II were also summarized in table 4-3.

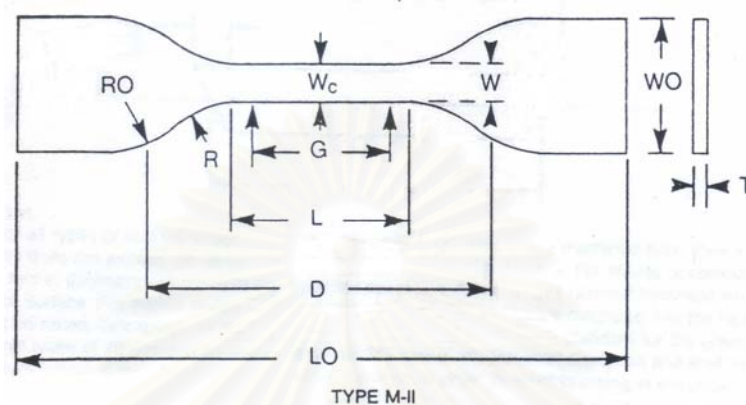

Figure 4-8 Tensile testing specimen.

Table 4-3 Dimension of tensile specimen.

Dimensions	mm
W - Width of narrow section	6
L - Length of narrow section	33
W _o - Width of overall	25
L _o - Length overall	115
G - Gage length	25
D - Distance between grips	80
R - Radius of fillet	14
R _o - Outer radius	25
T - Thickness	4 or less

The determination of tensile properties was carried out at constant cross head speed of 50 mm/min with load cell of 1,000 N. The results from the tests include tensile strength and modulus of elasticity; the average value of six specimens was reported.

CHAPTER 5

RESULTS AND DISCUSSIONS

5.1 The Appropriate Methods of Mixing Polymer and Low Molecular Weight Liquid Crystal

The experimental methods were described in chapter 4, section 4.3. The torque values of the internal mixer used when melting pure HDPE, HDPE blended with low molecular weight liquid crystal (LCC) by adding BCH-5 0.1% by weight twice directly into the mixing chamber, HDPE blended with BCH-5 by dry mixing in a plastic bag and HDPE blended with BCH-5 by using the master batch of BCH-5 are shown in table 5-1. The BCH-5 concentration about 0.2% by weight was used in all cases.

Table 5-1 The torque values of the internal mixer used when melting pure HDPE and HDPE blended with BCH-5.

Sample	Torque (Nm)
Pure HDPE	67.8 ± 0.1
HDPE+ BCH-5 0.1% by weight twice	65.6 ± 0.1
HDPE+ BCH-5 by dry mixing	66.0 ± 0.1
HDPE + BCH-5 by using the master batch of BCH-5	50.3 ± 0.1

The effects of low molecular weight liquid crystal on the torque value of the internal mixer used when melting HDPE could be observed in the mixing experiments. The torque values of the internal mixer used when melting the blends containing BCH-5 were lower than the torque value of the internal mixer used when melting pure HDPE. When HDPE was blended with BCH-5 by adding BCH-5 0.1% by weight twice directly into the mixing chamber, the torque value of the internal mixer used when melting the blend was reduced about 3% when compared with the torque value of the internal mixer used when melting pure HDPE. In the case of HDPE blended with BCH-5 by dry mixing in the plastic bag, the torque value of the internal mixer used when melting the blend was also reduced about 3%. The lowest torque value of the internal mixer used when melting the blend was

recorded, when HDPE was blended with BCH-5 by using the master batch of BCH-5, the torque value of the internal mixer used when melting the blend was reduced about 26%.

Differences in observed torque value values of the internal mixer when melting the blends could be attributed to different mixing methods as well as the amount of BCH-5 effectively mixed with HDPE matrix. When HDPE was blended with BCH-5 by adding BCH-5 0.1% by weight twice directly into the mixing chamber, the powder of BCH-5 were stucked at the lower surface of the ram, so the concentration of BCH-5 in the mixing chamber might be lower than 0.2% by weight. When HDPE was blended with BCH-5 by dry mixing in the plastic bag, the powder of BCH-5 were stucked at surface of the plastic bag, it might reduce the quantity of BCH-5 to be less than 0.2% by weight as found when adding BCH-5 0.1% by weight twice directly into the mixing chamber. The torque value of the internal mixer used when melting the blends of both methods showed only slight decreases. Therefore, among the three methods of mixing, an appropriate method of mixing HDPE and BCH-5 was by blending the HDPE with master batch of BCH-5 indicated by the lowest torque value of the internal mixer observed during processing. This was judged by the torque value reduction during blending presumably due to the less viscous blend system.

Due to the good processability of HDPE, these experiments were performed in order to hint the preliminarily proper methods to distribute the BCH-5 in the main polymers. This result showed that the master batch method is the proper method to distribute the LCC. Although it has the different processability between HDPE and PC, we presumed that the master batch method could be applied in the case of PC as shown in HDPE systems. In the previous works of S. Powanusorn [4], if we applied the LCC that have the nematic range in the melting temperature of the main polymers, the phenomenon of reduction in the melt viscosities will be also found regardless of the type of LCC and the main polymer used. Although the differences in the LCC used in HDPE system (BCH-5) and the PC systems (CBC-33), the reductions in the melt viscosities of both systems will be similarly found. We presumed the method of master batch could be applied in this research.

5.2 The Appropriate Concentration of Low Molecular Weight Liquid Crystal Master Batch and Rotor Speed of the Internal Mixer

The experimental methods were described in chapter 4, section 4.4. The total amount of BCH-5 was about 0.2% by weight in all cases. The torque values of the internal mixer used when melting pure HDPE and HDPE blended with the master batch of BCH-5 in various concentrations of 1.1, 2.2, 4.4 and 8.8% by weight are shown in table 5-2.

Table 5-2 The torque values of the internal mixer used when melting the blends at various concentrations of the master batch of BCH-5 and rotor speeds.

Concentration of Master batch (%)	Torque at 10 rpm (Nm)	Torque at 20 rpm (Nm)	Torque at 40 rpm (Nm)	Torque at 80 rpm (Nm)
0	28.9 ± 0.1	39.8 ± 0.1	52.4 ± 0.1	61.7 ± 0.1
1.1	29.4 ± 0.1	40.7 ± 0.1	52.4 ± 0.1	62.8 ± 0.1
2.2	27.4 ± 0.1	38.6 ± 0.1	50.6 ± 0.1	60.1 ± 0.1
4.4	26.3 ± 0.1	37.6 ± 0.1	50.3 ± 0.1	59.1 ± 0.1
8.8	26.9 ± 0.1	37.2 ± 0.1	49.6 ± 0.1	59.3 ± 0.1

Table 5-3 The temperature ranges of the internal mixer used when melting the blends at various concentrations of the master batch of BCH-5 and rotor speeds.

Concentration of Master batch (%)	Temp. at 10 rpm (°C)	Temp. at 20 rpm (°C)	Temp. at 40 rpm (°C)	Temp. at 80 rpm (°C)
0	201-188	188-189	189-199	199-222
1.1	201-187	187-189	189-199	199-224
2.2	199-187	187-188	188-198	198-221
4.4	200-188	188-189	189-199	199-223
8.8	200-187	187-189	189-198	198-222

From table 5-2 the torque value of the internal mixer used when melting the blend of HDPE and the master batch of BCH-5 concentration about 8.8% by weight was tended to reduced in the largest amount when compared with the pure HDPE. So, the suitable concentration of master batch of BCH-5 was about 8.8% by weight because at this concentration the master batch has the uniform mixture when prepared on the digital hot plate. From table 5-3, the temperature ranges of the internal mixer used when melting the blends were relatively the same for all concentrations of master batch of BCH-5.

Due to the good processability of HDPE, these experiments were performed in order to hint the preliminarily proper concentration of master batch to distribute the LCC in the main polymers. This result showed that the suitable concentration of master batch was about 8.8% by weight is the proper concentration to distribute the LCC. In the previous works of S. Powanusorn [4], if we applied the LCC that have the nematic range in the melting temperature of the main polymers, the phenomenon of reduction in melt viscosities will be also found regardless of the type of LCC and the main polymer used. Although the differences in the LCC used in HDPE system (BCH-5) and the PC systems (CBC-33), the reductions in the melt viscosities of both systems will be similarly found. In further studies on blends of PC containing LCC, blending method via master batch with a concentration of 8.8% by weight will be used. This master batch concentration was selected based on its uniform mixing prepared on the digital hot plate.



สถาบันวิทยบริการ
จุฬาลงกรณ์มหาวิทยาลัย

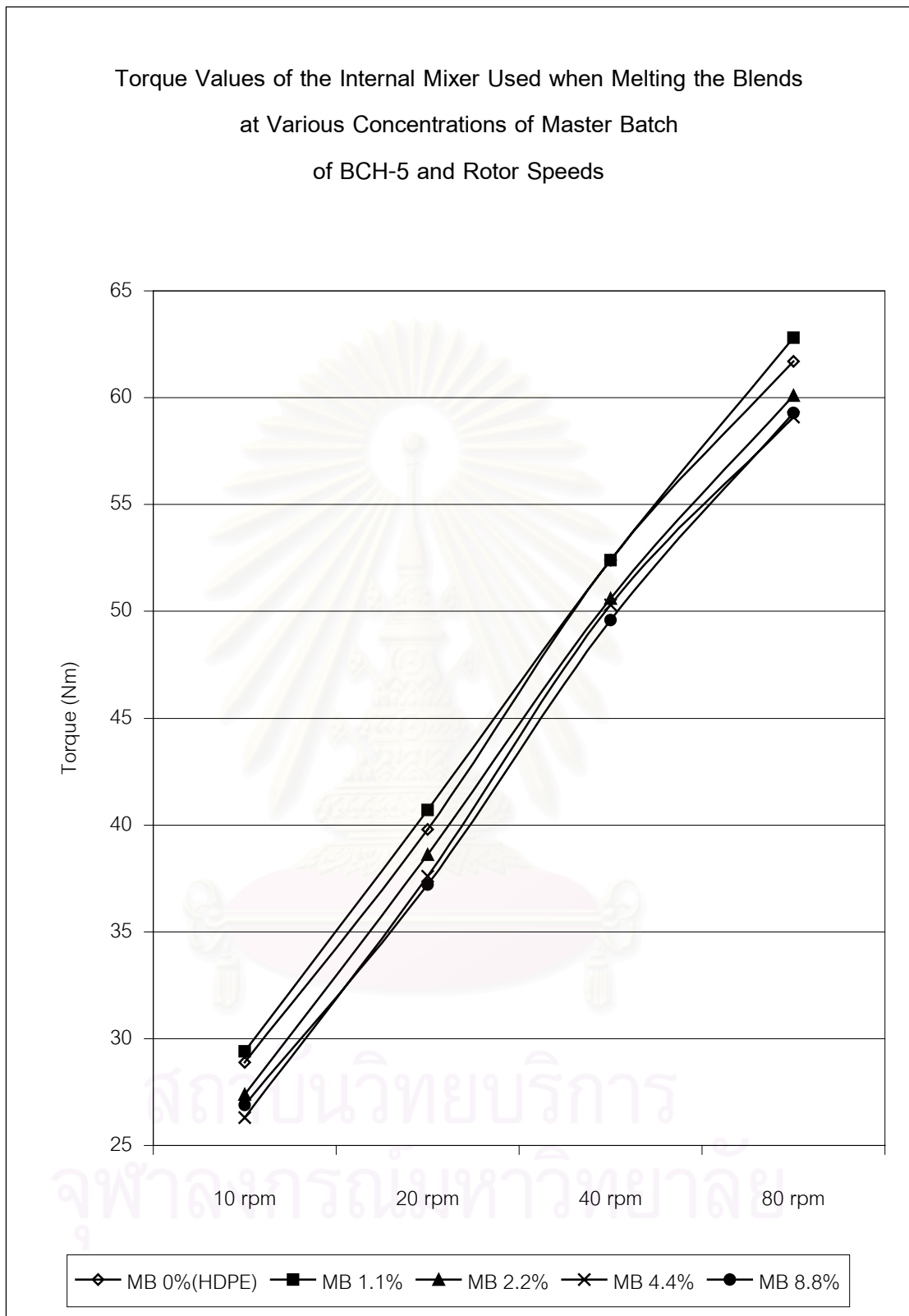

Figure 5-1 Torque values of the internal mixer used when melting the blends at various concentrations of the master batch of BCH-5 and rotor speeds.

5.3 The Appropriate Operating Temperature for Polycarbonate in the Internal Mixer

The experimental methods were described in chapter 4, section 4.5. The torque values of the internal mixer used when melting pure PC2600 at various the operating temperatures of 280, 270, 250, 230 and 200 °C are shown in table 5-4.

Table 5-4 The torque values of the internal mixer used when melting pure PC2600 at various the operating temperatures at rotor speed of 40 rpm.

Operating Temperature (°C)	Torque (Nm)	Energy Consumption* (J/s)	Color of Sample
200	82.1 ± 0.5	18.5	Clear
230	34.5 ± 0.2	9.6	Yellow
250	15.6 ± 0.1	6.1	Yellow
270	12.5 ± 0.1	4.1	Light Brown
280	6.6 ± 0.1	3.2	Brown

* Energy consumption is defined as the energy required to process a certain material for a certain period of time at given conditions, calculated from area under the torque curve by Sigma Plot program Version 8.0.

In this study, the appropriate operating temperature for polycarbonate in the internal mixer was selected to be 200 °C because the degradation of polycarbonate occurred at temperature above 200 °C indicated by the change of the color to be yellow or brown. However, the torque value of the internal mixer used when melting at 200 °C is the highest. The more energy consumed is compensated by retaining the quality of the polycarbonate.

5.4 Effects of Mixing Low Molecular Weight Liquid Crystal on the Operating Torque of the Internal Mixer

The experimental methods were described in chapter 4, section 4.6. The torque values of the internal mixer used when melting pure PC2600, PC2405 and their blends with low molecular weight liquid crystal (CBC-33) are shown in table 5-5.

Table 5-5 The torque values of the internal mixer used when melting pure PC2600, PC2405 and their blends with CBC-33.

Samples	Torque (Nm)	Energy Consumption (J/s)
Pure PC2600	82.1 ± 0.5	18.5
PC2600 + Master batch of CBC-33	66.1 ± 0.3	16.5
PC2600 Remix*	93.4 ± 0.5	19.5
Pure PC2405	65.5 ± 0.7	14.0
PC2405 + Master batch of CBC-33	70.1 ± 0.3	14.5
PC2405 Remix	72.1 ± 0.4	15.9

* Remix is the mixing of polycarbonate and CBC-33 twice, the first mixing was prepared by melt blending on hot plate and the second mixing was blended in the mixing chamber of the internal mixer.

The effects of low molecular weight liquid crystal on the torque values of the internal mixer used when melting the polycarbonates could be seen that the torque value of the internal mixer during melting PC2600 blended with master batch of CBC-33 was about 20% lower than torque value of the internal mixer used when melting pure PC2600. The energy consumption was lower than pure PC2600 about 10%. The torque value of the internal mixer used when melting PC2600 remix was about 14% higher than the torque value of the internal mixer used when melting pure PC2600 and the energy consumption was higher than pure PC2600 about 5%. In the case of PC2405 blended with the master batch of CBC-33 and PC2405 remix, their operating torque values on the internal mixer and energies consumption slightly increased when compared with the torque value of the internal mixer used when melting pure PC2405 and energy consumption of pure PC2405. The

changes of the torque values of the internal mixer during melting the blends might be the effects of the deformation and orientation of liquid crystal molecules [16] that tends to reduce the viscosity of polymer blends.

5.5 The Appropriate Operating Temperature and Screw Speed for Polycarbonate in the Single Screw Extruder

The experimental methods were described in chapter 4, section 4.7. The torque values of the single screw extruder used when extruding pure PC2600 at various operating temperature ranges are shown in table 5-6. The torque values of the single screw extruder used when extruding pure PC2600 at two different screw speeds of 20 and 40 rpm are shown in table 5-7.

Table 5-6 The torque values of the single screw extruder used when extruding pure PC2600 at various operating temperature ranges at screw speed of 40 rpm.

Zone 1 (°C)	Zone 2 (°C)	Zone 3 (°C)	Die Temperature (°C)	Torque (Nm)	Quality and Surface Appearance of Extrudate Rod
200	210	220	220	79.1 ± 1.5	Can not be melted
220	230	240	240	63.5 ± 1.2	Rough surface
240	250	260	260	59.0 ± 1.1	Rough surface
260	270	280	280	54.9 ± 1.4	Smooth surface

Table 5-7 The torque values of the single screw extruder used when extruding pure PC2600 at screw speeds of 20 and 40 rpm at the operating temperature of 260, 270, 280 °C for the three extruder zones and 280 °C for die zone

Screw Speed (rpm)	Torque (Nm)	Processability and Product Quality
20	30.3 ± 1.0	Continuous extrudate rod can be produced
40	54.9 ± 1.4	Continuous extrudate rod can not be produced

Based on experimental observations, the appropriate operating temperature range for pure PC2006 in the single screw extruder was selected to be 260, 270, 280 °C for the three extruder zones and 280 °C for die zone because the extruded polymer tended to melt completely indicated by smooth surface appearance of extrudate rod. The appropriate screw speed for pure PC2600 in the single screw extruder was found to be 20 rpm because at high speed of 40 rpm, the melted polymer agglomerated just in front of the die, in other words due to the lower melt viscosity of the polymer, it can not be drawn as a continuous extrudate rod but drip out from the die.

5.6 Effects of Mixing Low Molecular Weight Liquid Crystal on the Operating Torque of the Single Screw Extruder

The experimental methods were described in chapter 4, section 4.8. The torque values of the single screw extruder used when extruding pure PC2600, PC2600 blended with CBC-33, PC2600 remix, pure PC2405, PC2405 blended with CBC-33 and PC2405 remix are shown in table 5-8.

Table 5-8 The torque values of the single screw extruder used when extruding pure PC2600, pure PC2405 and their blends with CBC-33.

Samples	Torque (Nm)	Color of Sample
Pure PC2600	30.3 ± 0.4	Clear
PC2600 + Master batch of CBC-33	25.1 ± 0.3	Clear
PC2600 Remix*	7.2 ± 0.1	Light yellow
Pure PC2405	21.0 ± 0.4	Clear
PC2405 + Master batch of CBC-33	12.9 ± 0.1	Clear
PC2405 Remix	3.6 ± 0.1	Light yellow

* Remix is the mixing of PC2600 and CBC-33 twice by extruding PC2600-Master batch of CBC-33 blend twice.

In this study, the torque values of the single screw extruder used when extruding the blends between polycarbonates and CBC-33 were lower than pure polycarbonate. In the case of PC2600, the torque value of the single screw extruder used when extruding PC2600 and master batch of CBC-33 was decreased about 17%, and the torque value of the single screw extruder used when extruding PC2600 remix was reduced about 76%. In the case of PC2405, the torque value of the single screw extruder used when extruding PC2405 and master batch of CBC-33 was decreased about 39%, and the torque value of the single screw extruder used when extruding PC2405 remix was reduced about 83%.

This phenomenon might prove that LCC could act as a viscosity modifier of polycarbonate. Therefore, these can cause the reduction in the processing temperature of polycarbonate without significantly change the glass transition temperature which is important for polymer processing industries.

The reductions of the torque values of the single screw extruder used when extruding the blends might be the effects of the deformation and orientation of liquid crystal molecules [16] that tends to reduce the viscosity of polymer blends.

5.7 The Appropriate Operating Temperature and Screw Speed for Polycarbonate in the Twin Screw Extruder

The experimental methods were described in chapter 4, section 4.9. The torque values of the twin screw extruder used when extruding of pure PC2600 at various operating temperature ranges are shown in table 5-9. The torque values of the twin screw extruder used when extruding of pure PC2600 at two different screw speeds of 40 and 60 rpm are shown in table 5-10.

Table 5-9 The torque values of the twin screw extruder used when extruding of pure PC2600 at various operating temperature ranges at screw speed of 40 rpm.

Zone 1 (°C)	Zone 2 (°C)	Zone 3 (°C)	Die Temperature (°C)	Torque (Nm)	Quality and Surface Appearance of Extrudate Rod
220	230	240	240	38.9 ± 1.5	Rough surface
240	250	260	260	35.6 ± 0.8	Smooth surface
260	270	280	280	30.3 ± 0.9	Smooth surface

Table 5-10 The torque values of the twin screw extruder used when extruding of pure PC2600 at screw speed of 40 and 60 rpm at operating temperature range of 240, 250, 260 °C for the three extruder zones and 260 °C for die zone.

Screw Speed (rpm)	Torque (Nm)	Processability and Product Quality
40	35.6 ± 0.8	Continuous extrudate rods can not be produced
60	25.0 ± 0.7	Continuous extrudate rods can be produced

The experimental results revealed that the appropriate range of operating temperature for pure PC2600 in the twin screw extruder was selected to be 240, 250, 260 °C for the three extruder zones and 260 °C for die zone because the extruded polymer tended to melt completely indicated by smooth surface appearance of extrudate rods. The appropriate screw speed for pure PC2600 in the twin screw extruder was found to be 60 rpm. The extrudate at 40 rpm screw speed can not form the rods because it will tear off just after extruded from the die. This might be because of the low viscosity and low melt strength of the extrudate. Usually polymer melt can be drawn less than 700% of the original length [27]. The extrudate can be drawn into the rod shape at screw speed of 60 rpm possibly because of the increased mass flow rate or length/time suitable for the polymer's natural draw ratio and the screw speed fitted with the pelletizing draw capability too.

5.8 Effects of Mixing Low Molecular Weight Liquid Crystal on the Operating Torque of the Twin Screw Extruder

The experimental methods were described in chapter 4, section 4.10. The torque values of the twin screw extruder used when extruding pure PC2600, PC2600 blended with CBC-33, PC2600 remix, pure PC2405, PC2405 blended with CBC-33 and PC2405 remix are shown in table 5-11.

Table 5-11 The torque values of the twin screw extruder used when extruding pure PC2600, PC2405 and their blends with CBC-33.

Samples	Torque (Nm)	Color of Sample
Pure PC2600	25.1 ± 0.2	Clear
PC2600 + Master batch of CBC-33	27.2 ± 0.2	Clear
PC2600 Remix*	22.5 ± 0.3	Light yellow
Pure PC2405	31.0 ± 0.4	Clear
PC2405 + Master batch of CBC-33	43.5 ± 0.4	Clear
PC2405 Remix	15.2 ± 0.2	Light yellow

* Remix is the mixing of PC2600 and CBC-33 twice by extruding PC2600-Master batch of CBC-33 blend twice.

In this study, the torque value of the twin screw extruder used when extruding PC2600 blended with master batch of CBC-33 was increased about 8% when compared with pure PC2600. The torque value of the twin screw extruder used when extruding PC2600 remix was decreased about 10% when compared with pure PC2600. In the case of PC2405, torque value of the twin screw extruder used when extruding PC2405 blended with master batch of CBC-33 was increased about 40% when compared with pure PC2405. The torque value of the twin screw extruder used when extruding PC2600 remix was decreased about 51% when compared with pure PC2405. The changes of the torque values of the twin screw extruder used when extruding the blends might be the effects of the deformation and orientation of liquid crystal molecules [16] that tends to reduce the viscosity of polymer blends.

5.9 The Appropriate Operating Temperature for Polycarbonate in the Injection Molding Machine

The experimental methods were described in chapter 4, section 4.11. The operating temperatures for pure PC2600 are determined during the injection molding of tensile test specimens.

Table 5-12 The operating temperature ranges for pure PC2600 in the injection molding machine.

Zone 1 (°C)	Zone 2 (°C)	Zone 3 (°C)	Nozzle (°C)	Quality of Dumbbell Specimens
260	265	270	275	Short shot
265	270	275	280	Short shot
270	275	280	285	Short shot
275	280	285	290	Complete dumbbell specimens

The appropriate operating temperature range for pure PC2600 in the injection molding machine was selected to be 275, 280, 285 °C for three extruder zones and 290 °C for nozzle because the complete dumbbell specimens without short shots could be produced.

5.10 Effects of Various Low Molecular Weight Liquid Crystal Blends on the Operating Pressures of the Injection Molding Machine

The experimental methods were described in chapter 4, section 4.12. The operating pressures for PC2600 were determined during the injection molding of tensile test specimens (dumbbell). The operating pressures* for PC2600 at injection stroke were selected to be 160 and 145 bar, holding pressure** was selected to be 77 bar. In the case of PC2405, the operating pressures at injection stroke for PC2405 were selected to be 130 and 100 bar, holding pressure was selected to be 61 bar because defective specimens with flash occurred at high pressure of 160,145 bar at injection stroke, and holding pressure of 77 bar.

* Injection pressure is defined as the pressure needed in the cavity to produce consistent quality of specimens or parts. [28]

** Holding pressure is defined as the pressure during the packing of the mold as was used during the filling of the mold. The level of the pressure setting is that which gives good mold fill-out without flashing the mold. [28]

5.11 Mechanical Properties

The experimental methods were described in chapter 4, section 4.13. The tensile strengths and modulus of elasticity values of pure PC2600, PC2405 and their blends with CBC-33 were determined to investigate the effects of CBC-33 on the mechanical properties of polycarbonates.

5.11.1 Tensile Strength

Figures 5-2 to 5-7 show the tensile strengths of pure PC2600, PC2405 and their blends with CBC-33 by mixing in the internal mixer, single screw extruder and twin screw extruder. From all figures, tensile strengths of pure PC2600, PC2405 and their blends with CBC-33 are relatively the same, the differences in the tensile strengths between pure PC2600, PC2405 and their blends with CBC-33 are less than 10 percent for all mixing processes.

Table 5-13 Tensile strengths of pure PC2600, PC2405 and their blends with CBC-33 by mixing in the internal mixer, single screw extruder and twin screw extruder.

Sample	Tensile Strength (MPa) Internal Mixer	Tensile Strength (MPa) Single Screw Extruder	Tensile Strength (MPa) Twin Screw Extruder
Pure PC2600	38.9 ± 4.8	36.2 ± 3.2	35.0 ± 4.5
PC2600+Master Batch of CBC-33	37.0 ± 2.5	39.3 ± 2.5	36.9 ± 3.3
PC2600 Remix	37.0 ± 5.8	37.9 ± 4.7	37.0 ± 2.1
Pure PC2405	38.8 ± 10.1	37.4 ± 4.3	38.5 ± 6.3
PC2405+Master Batch of CBC-33	37.5 ± 7.7	40.0 ± 3.6	41.1 ± 5.2
PC2405 Remix	40.8 ± 12.7	39.0 ± 5.8	40.7 ± 9.4

The tensile strength results were similar to that found by S. Powanusorn [4]. However, his results showed the variations of the tensile strengths in the range of $\pm 4\%$ when added the same amount of LCC in the polymer.

Usually the low molecular weight polymer will have the rubbery response under the tensile stretch more than the rigid high molecular weight polymer [27]. This related to the crack propagation phenomena and the rubbery state tends to have broader range of the tensile strength than the brittle rigid polymer. This might be the reason why PC2405 will have broader standard deviation from the tensile strength than the PC2600.

5.11.2 Modulus of Elasticity

Figures 5-2 to 5-7 show the modulus of elasticity values of pure PC2600, PC2405 and their blends with CBC-33 by mixing in the internal mixer, single screw extruder and twin screw extruder. From all figures, modulus of elasticity values of pure PC2600, PC2405 and their blends with CBC-33 are relatively the same, the differences in the modulus of elasticity values between pure PC2600, PC2405 and their blends with CBC-33 are less than 10 percent for all mixing processes.

Table 5-14 Modulus of elasticity values of pure PC2600, PC2405 and their blends with CBC-33 by mixing in the internal mixer, single screw extruder and twin screw extruder.

Sample	Modulus of Elasticity (MPa) Internal Mixer	Modulus of Elasticity (MPa) Single Screw Extruder	Modulus of Elasticity (MPa) Twin Screw Extruder
Pure PC2600	749 ± 56	768 ± 23	742 ± 24
PC2600+Master Batch of CBC-33	788 ± 22	781 ± 12	763 ± 17
PC2600 Remix	701 ± 52	755 ± 51	784 ± 29
Pure PC2405	699 ± 36	722 ± 56	732 ± 44
PC2405+Master Batch of CBC-33	758 ± 27	764 ± 37	752 ± 46
PC2405 Remix	715 ± 32	699 ± 61	714 ± 33

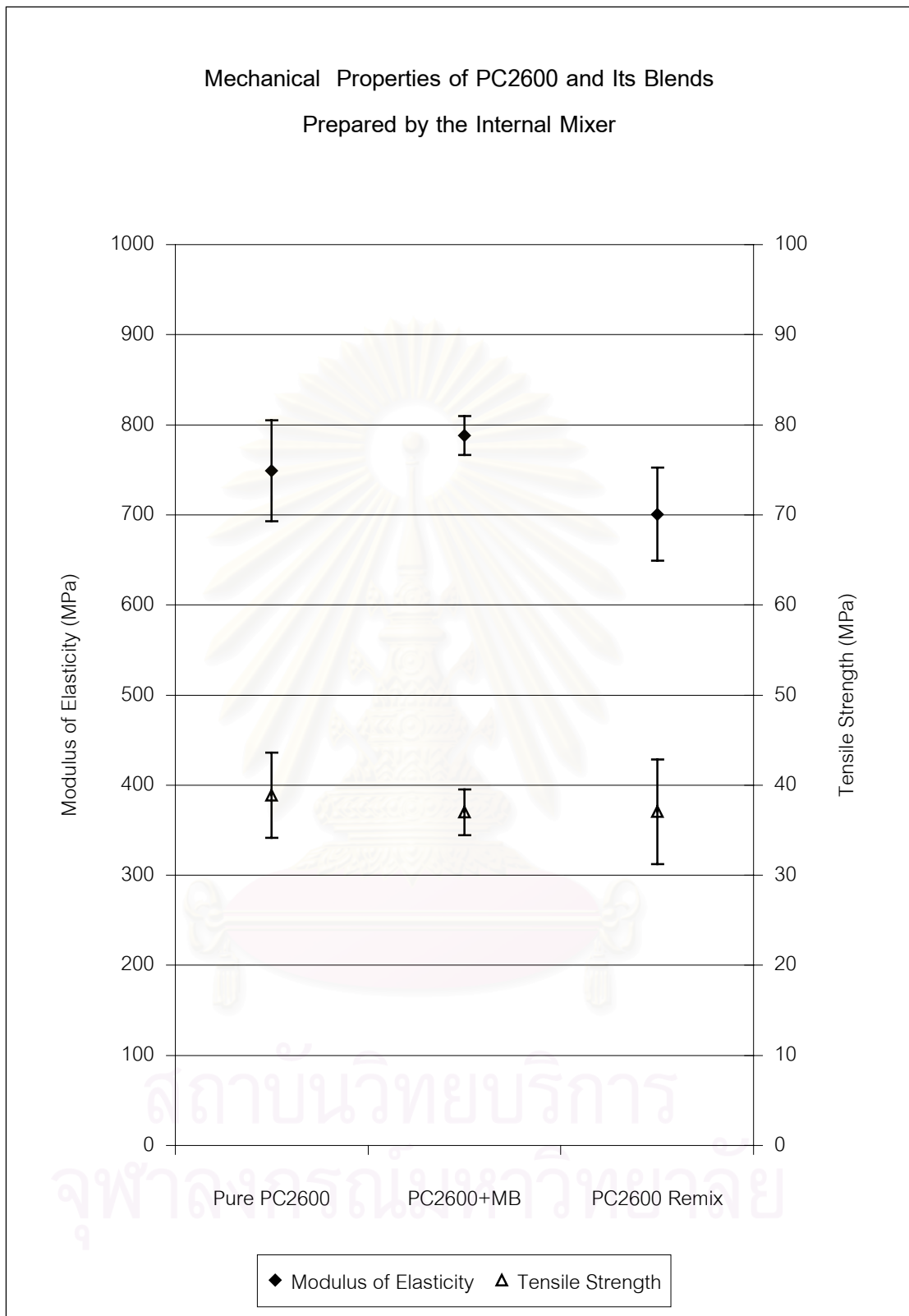

Figure 5-2 Mechanical Properties of PC2600 and its blends prepared by the internal mixer.

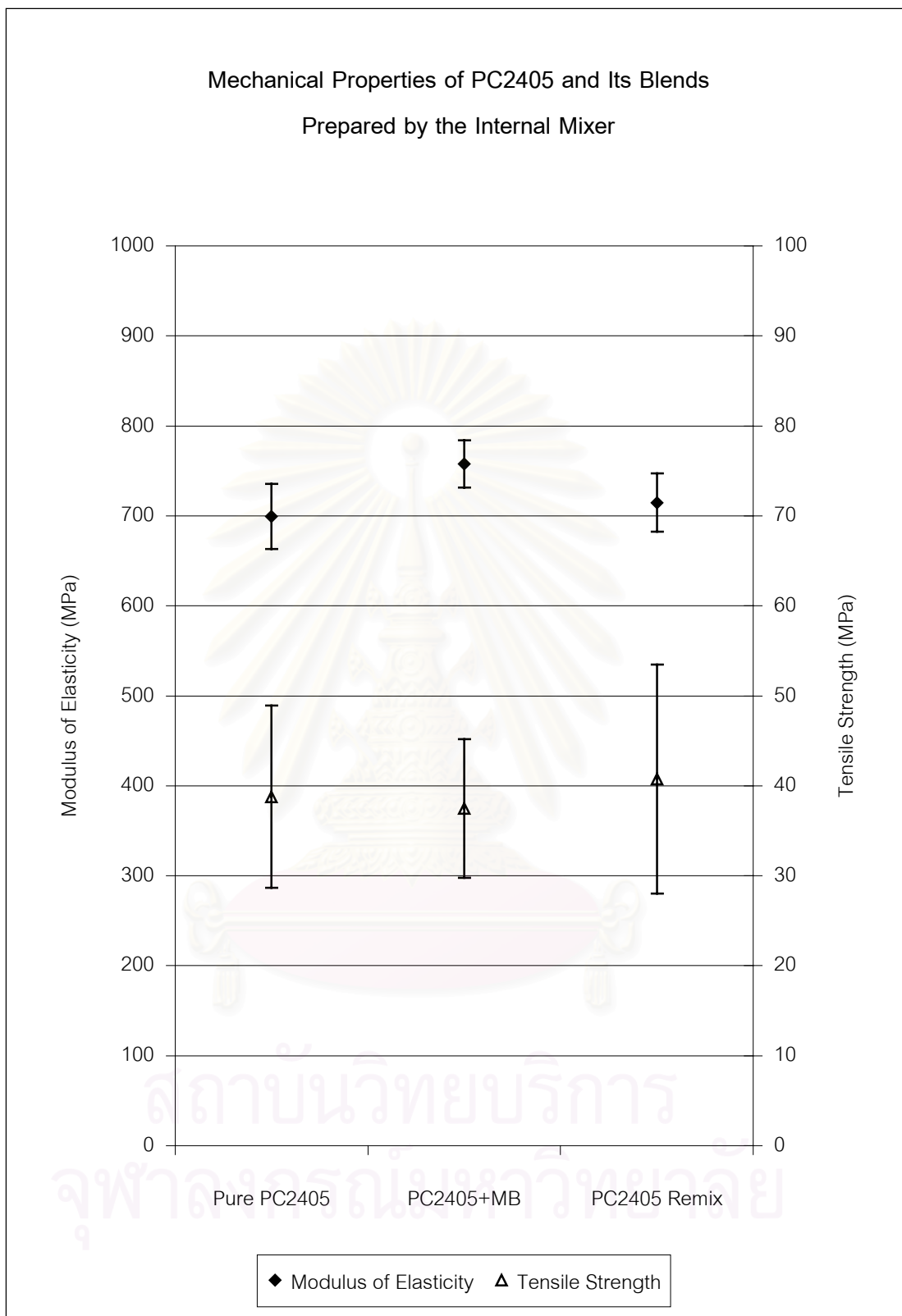

Figure 5-3 Mechanical Properties of PC2405 and its blends prepared by the internal mixer.

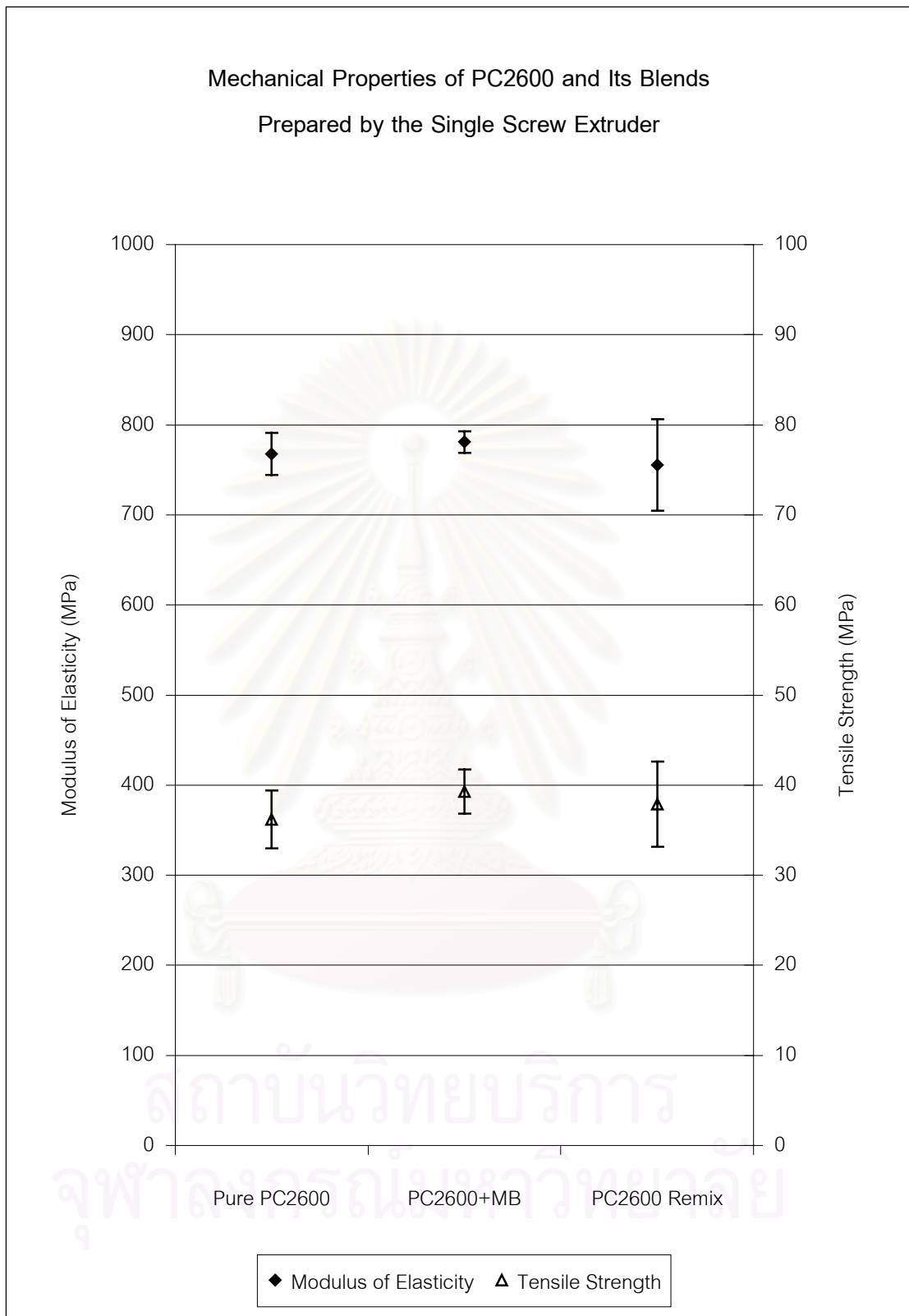

Figure 5-4 Mechanical Properties of PC2600 and its blends prepared by the single screw extruder.

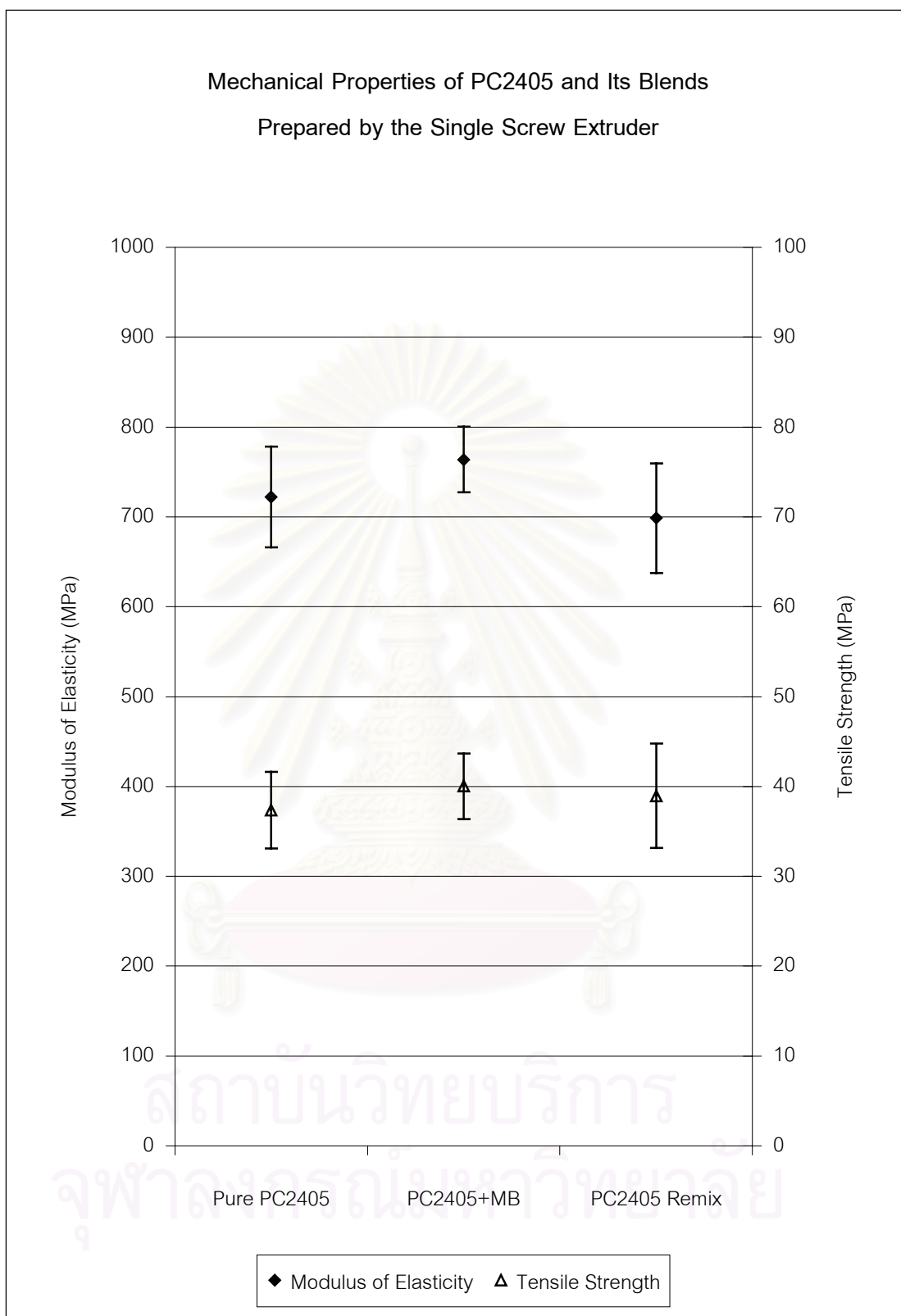

Figure 5-5 Mechanical Properties of PC2405 and its blends prepared by the single screw extruder.

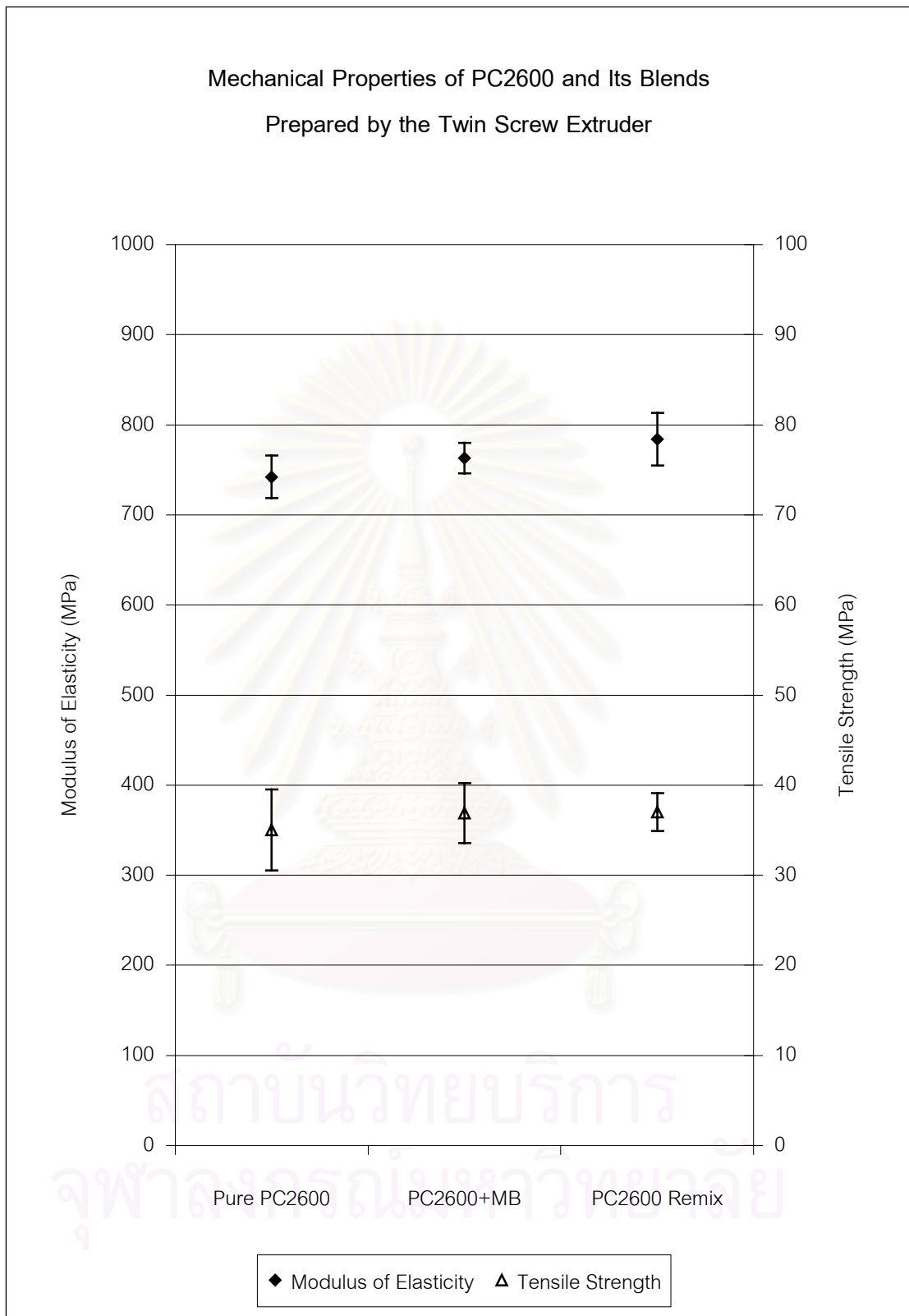

Figure 5-6 Mechanical Properties of PC2600 and its blends prepared by the twin screw extruder.

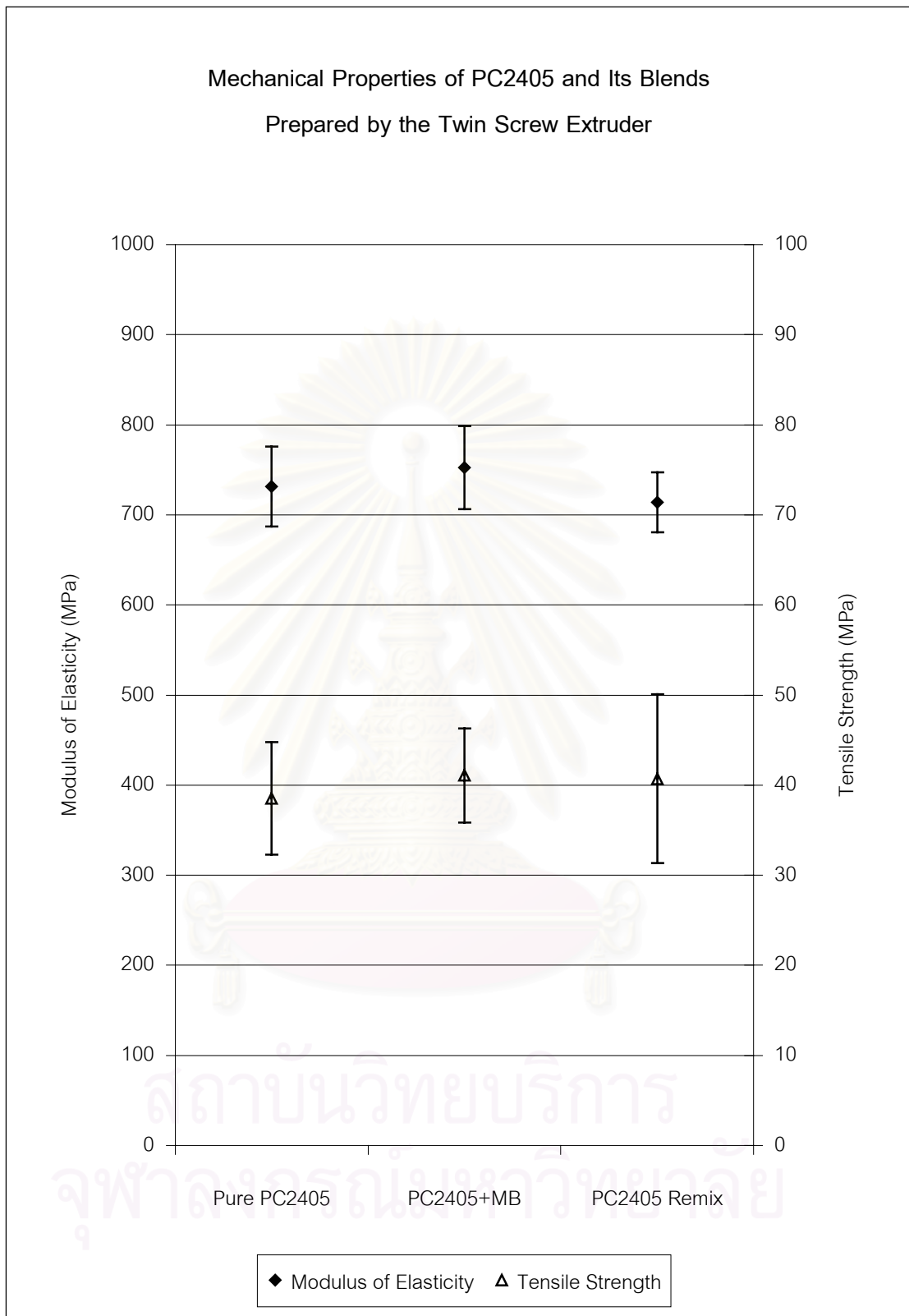

Figure 5-7 Mechanical Properties of PC2405 and its blends prepared by the twin screw extruder.

5.12 Thermal Properties

The thermal property of interest in this study is the glass transition temperature (T_g) of PC2600 before and after blending with CBC-33 by the twin screw extruder. Table 5-15 and figures 5-8 to 5-11 show T_g of PC2600 before and after blending with CBC-33 by the twin screw extruder. T_g results were obtained from differential scanning calorimetry. The weight of each sample about 15 mg. Samples were placed on the aluminium pan and heated at the rate of 20 °C/min from room temperature to 200 °C, held for 5 minutes, then quenched to room temperature at cooling rate of 20 °C/min, held for 5 minutes and heated again at the rate of 10 °C/min. The T_g value is the middle point of the specific heat change. The second run T_g was used in order to avoid the effect of thermal history.

Table 5-15 Glass transition temperatures of PC2600 before and after blending with CBC-33 by the twin screw extruder.

Sample	Glass Transition Temperature (°C)
Pure PC2600 before blending by the twin screw extruder	147
Pure PC2600 after blending by the twin screw extruder	147
PC2600 + Master batch of CBC-33 after blending by the twin screw extruder	146
PC2600 Remix after blending by the twin screw extruder	145

From table 5-15, The glass transition temperatures of PC2600 before and after blending with CBC-33 by the twin screw extruder are relatively the same. These phenomena may be the results of small amount of CBC-33 in PC2600 matrix phase that are not enough to plasticize the polycarbonate similar to the previous works of S. Powanusorn [4] that found the difference between T_g of pure polymer and its blends is around 3 °C.

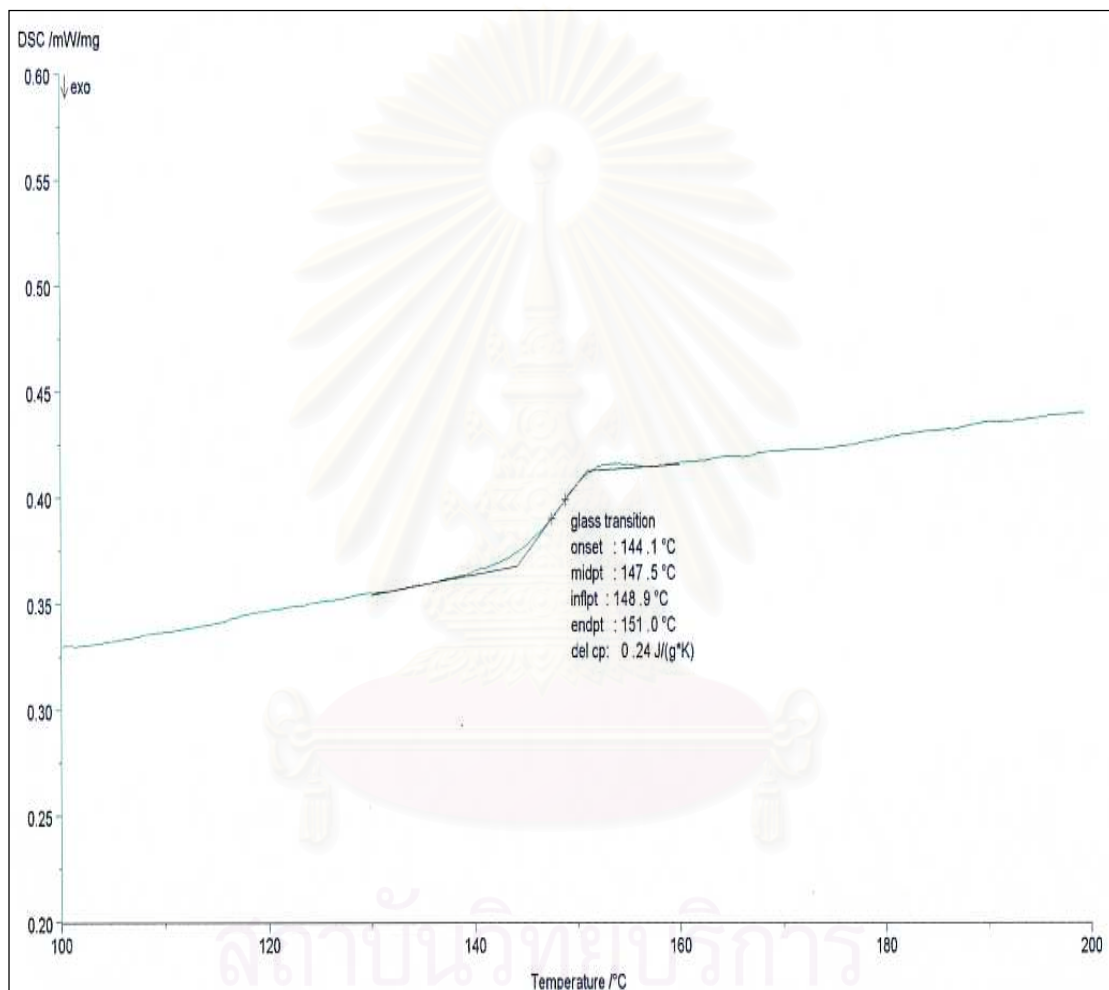

Figure 5-8 DSC thermogram of pure PC2600 before blending by the twin screw extruder.

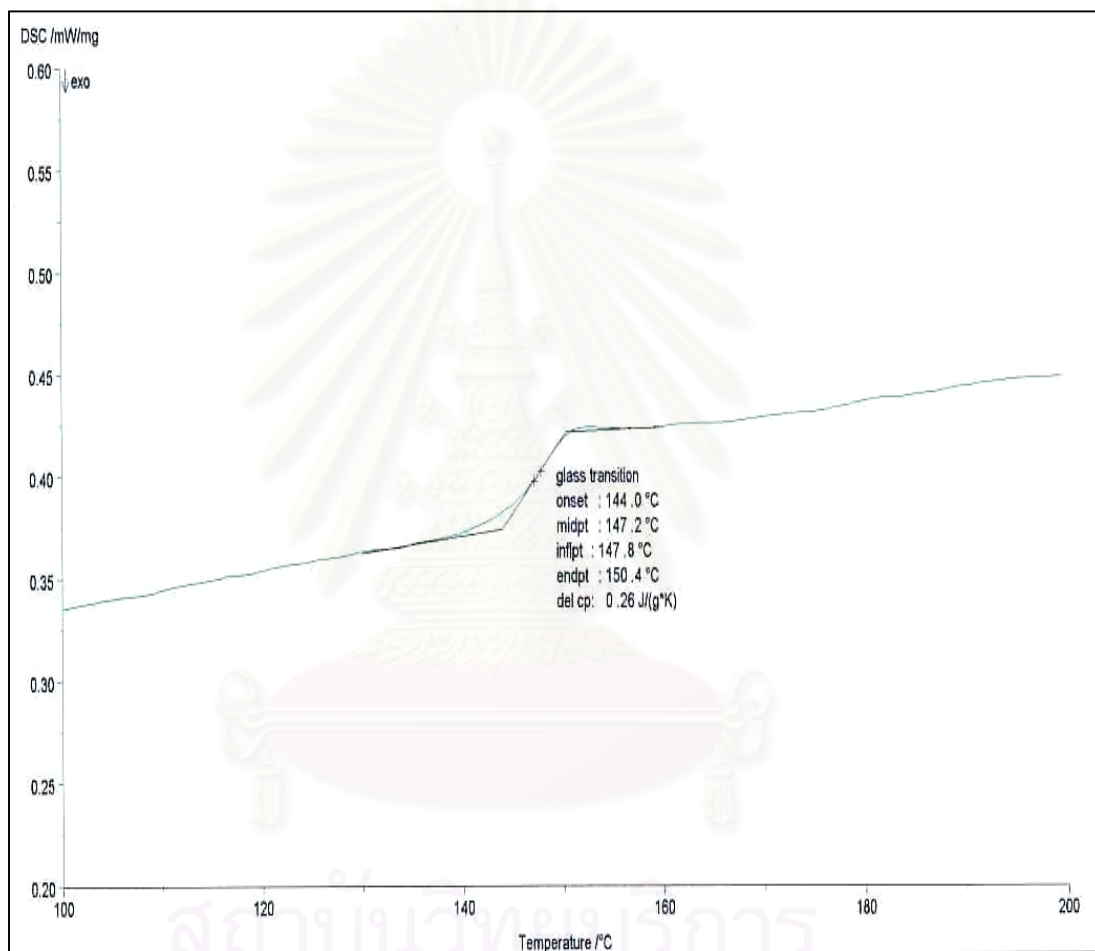

Figure 5-9 DSC thermogram of pure PC2600 after blending by the twin screw extruder.

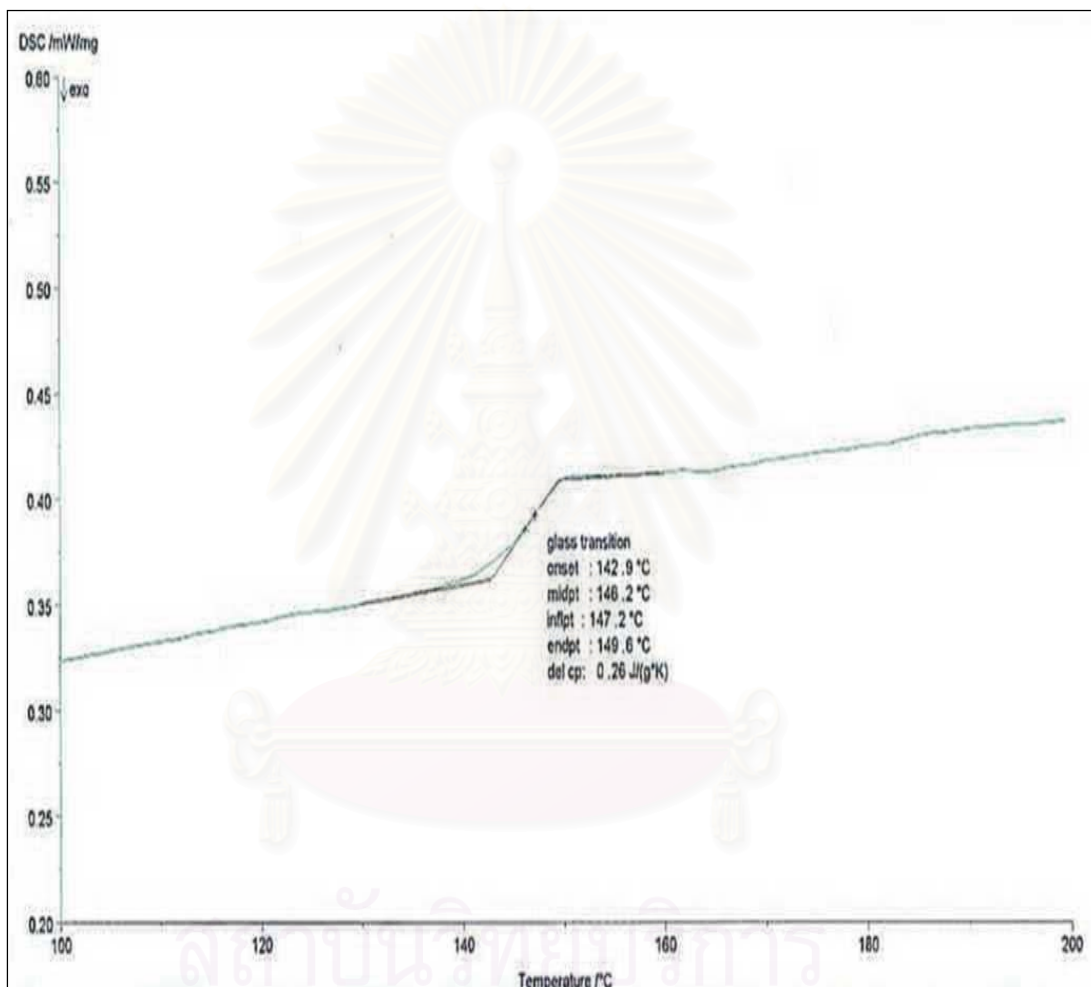

Figure 5-10 DSC thermogram of PC2600 blended with master batch of CBC-33 after blending by the twin screw extruder.

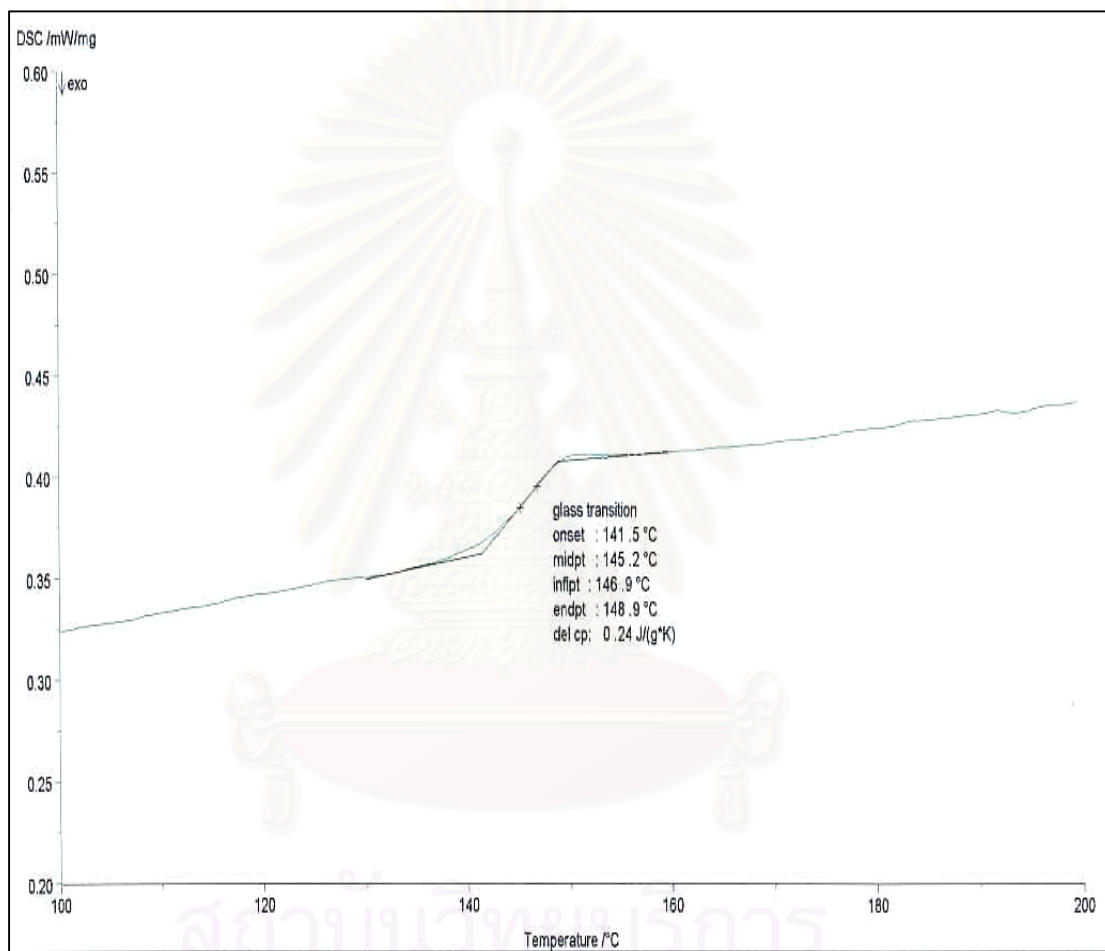

Figure 5-11 DSC thermogram of PC2600 remix after blending by the twin screw extruder.

5.13 Molecular Weight and Molecular Weight Distribution

Table 5-16 and figures 5-12 to 5-19 show the results of weight average molecular weight (Mw), number average molecular weight (Mn) and molecular weight distribution (MWD) of PC2600 and PC2405 before and after blending with CBC-33 by the internal mixer. Mw, Mn and MWD were obtained from gel permeation chromatography.

Table 5-16 Weight average molecular weight (Mw), number average molecular weight (Mn) and molecular weight distribution (MWD) of PC2600 and PC2405 before and after blending with CBC-33 by the internal mixer.

Sample	Mw	Mn	MWD
Pure PC2600 before blending by the internal mixer	43493	17159	2.53
Pure PC2600 after blending by the internal mixer	40762	16661	2.44
PC2600 + Master batch of CBC-33 after blending by the internal mixer	39145	13400	2.92
PC2600 remix after blending by the internal mixer	39946	18239	2.19
Pure PC2405 before blending by the internal mixer	35806	15204	2.35
Pure PC2405 after blending by the internal mixer	34213	14931	2.29
PC2405 + Master batch of CBC-33 after blending by the internal mixer	33747	12257	2.75
PC2405 remix after blending by the internal mixer	33727	15578	2.16

From table 5-16 the Mw, Mn and MWD of PC2600 and PC2405 before and after blending with CBC-33 by the internal mixer were slightly changed. The weights average molecular weight of PC2600 and PC2405 blended with CBC-33 are not significantly different when compared with the pure PC2600 and PC2405. The differences of weights average molecular weight between pure polycarbonate and blends were less than 4% for both PC2600 and PC2405. The molecular weight distributions of PC2600 and PC2405 blended with master batch of CBC-33 were broader than the pure polycarbonate. However, in the case of PC2600 remix and PC2405 remix the molecular weight distributions were narrower than the pure polycarbonate. Anyhow, these differences are too small to tell the difference of the polymer blend systems. In other words, no major difference in molecular characteristics can be concluded.

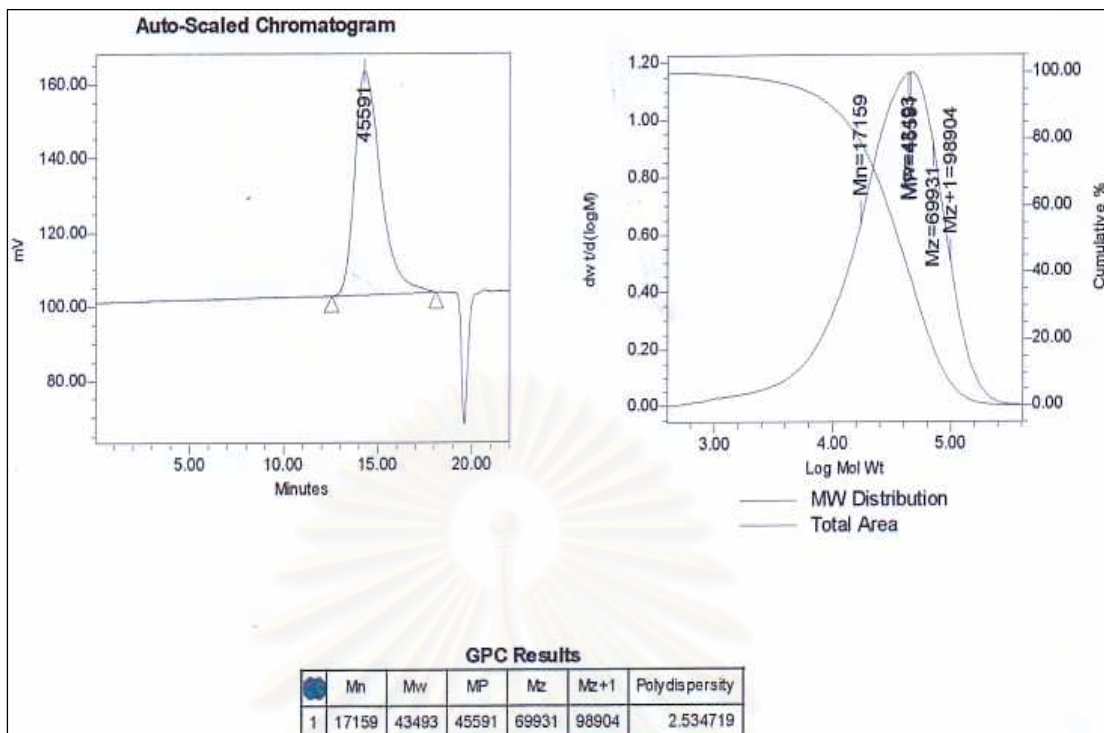

Figure 5-12 GPC chromatogram of pure PC2600 before blending by the internal mixer.

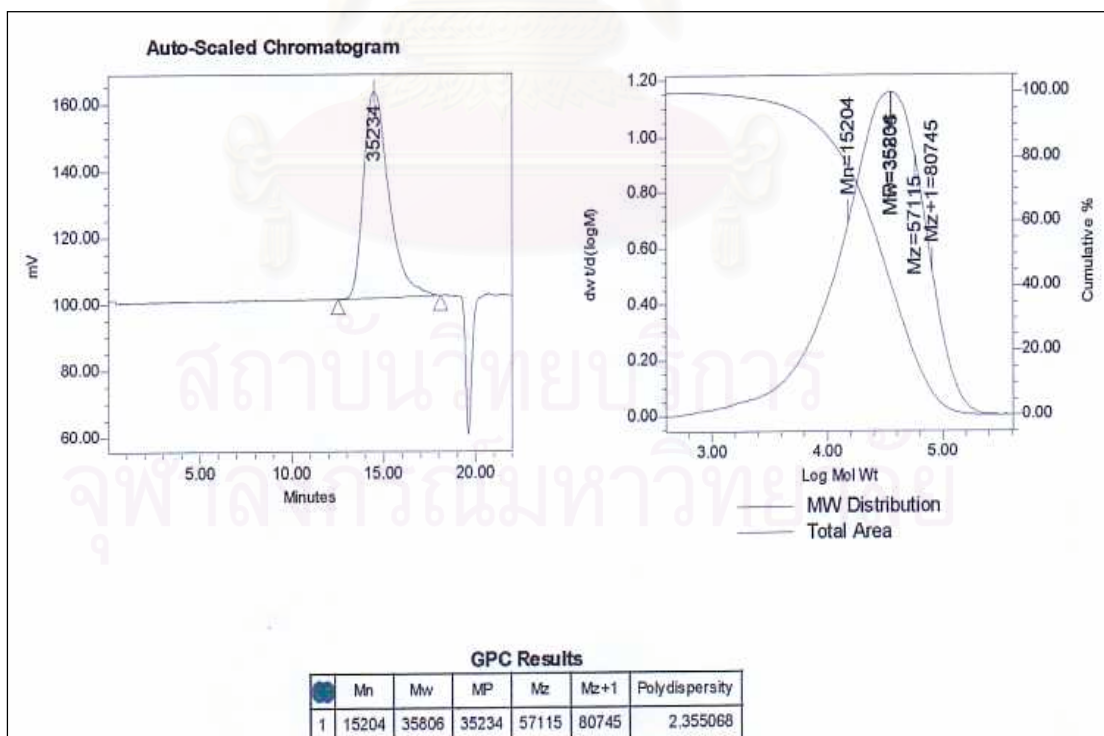

Figure 5-13 GPC chromatogram of pure PC2405 before blending by the internal mixer.

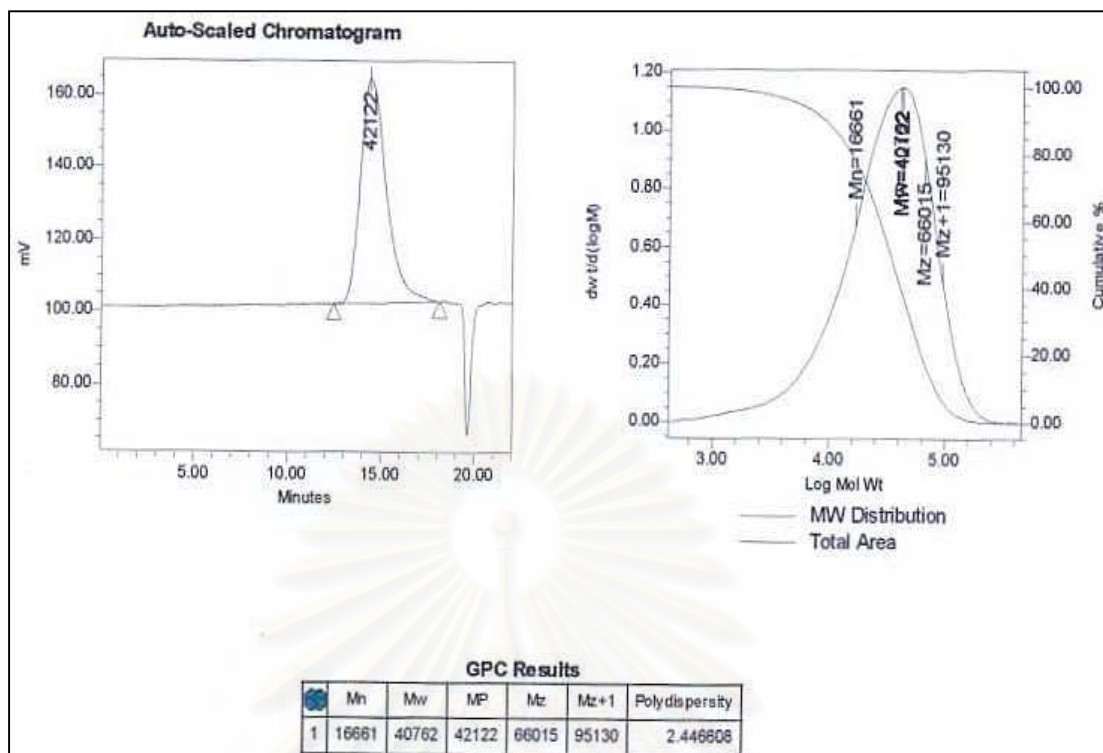

Figure 5-14 GPC chromatogram of pure PC2600 after blending by the internal mixer.

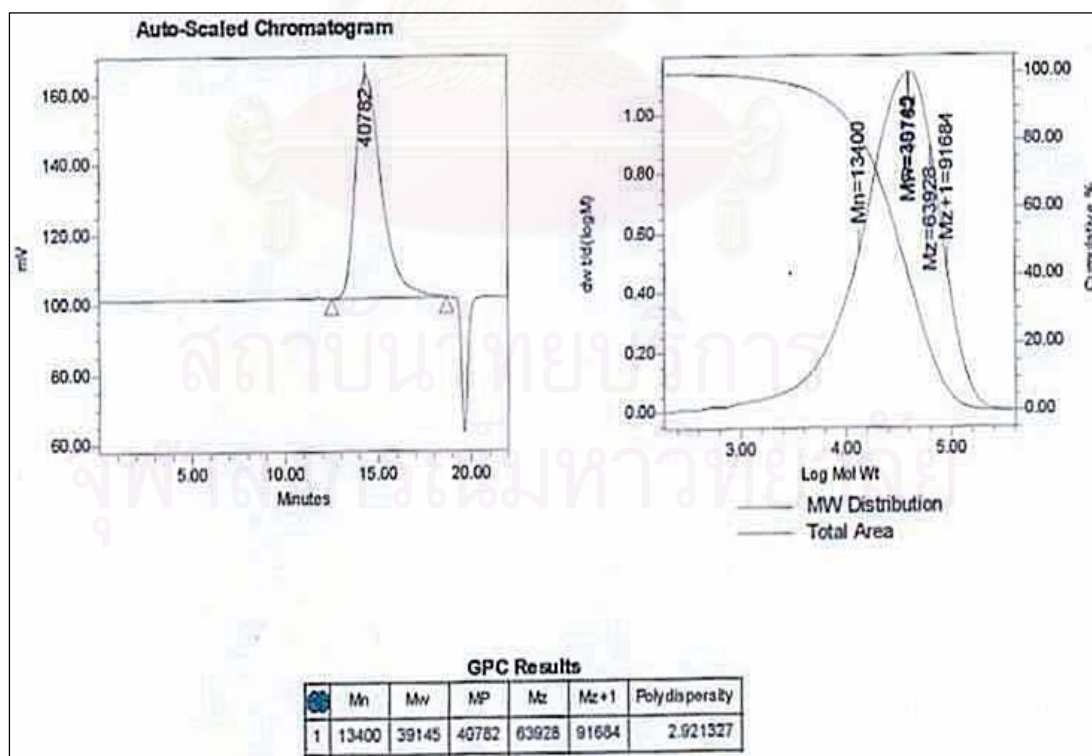

Figure 5-15 GPC chromatogram of PC2600 blended with master batch of CBC-33 after blending by the internal mixer.

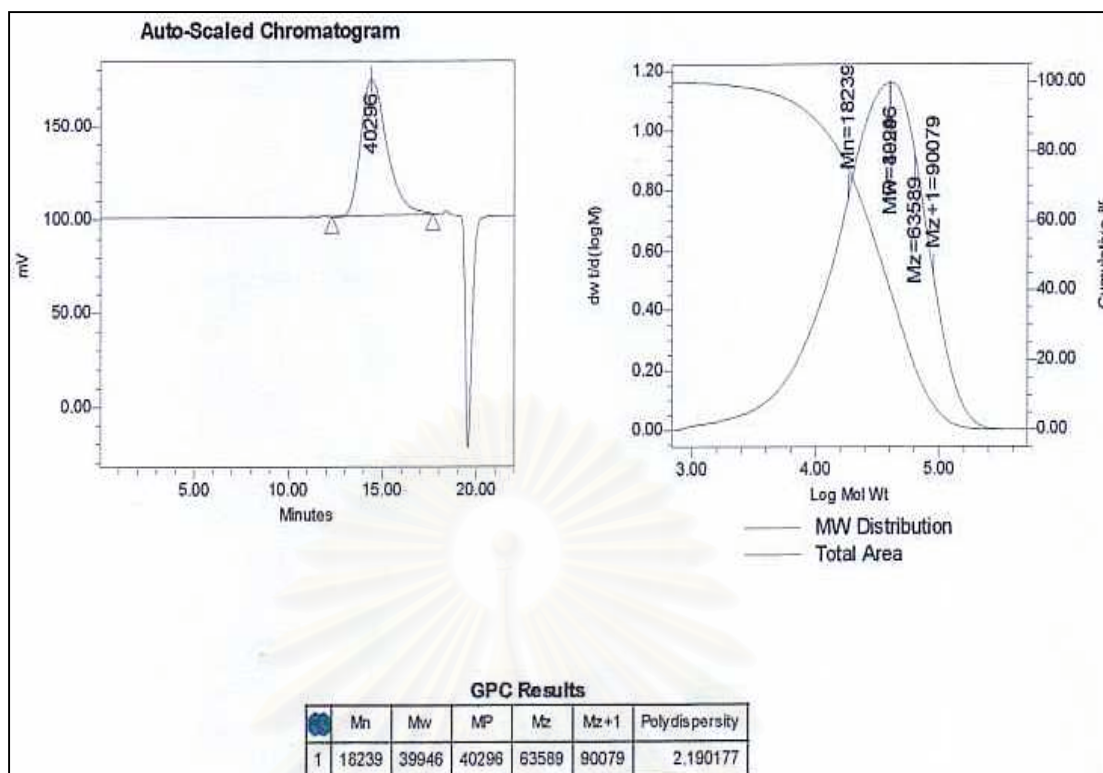

Figure 5-16 GPC chromatogram of PC2600 remix after blending by the internal mixer.

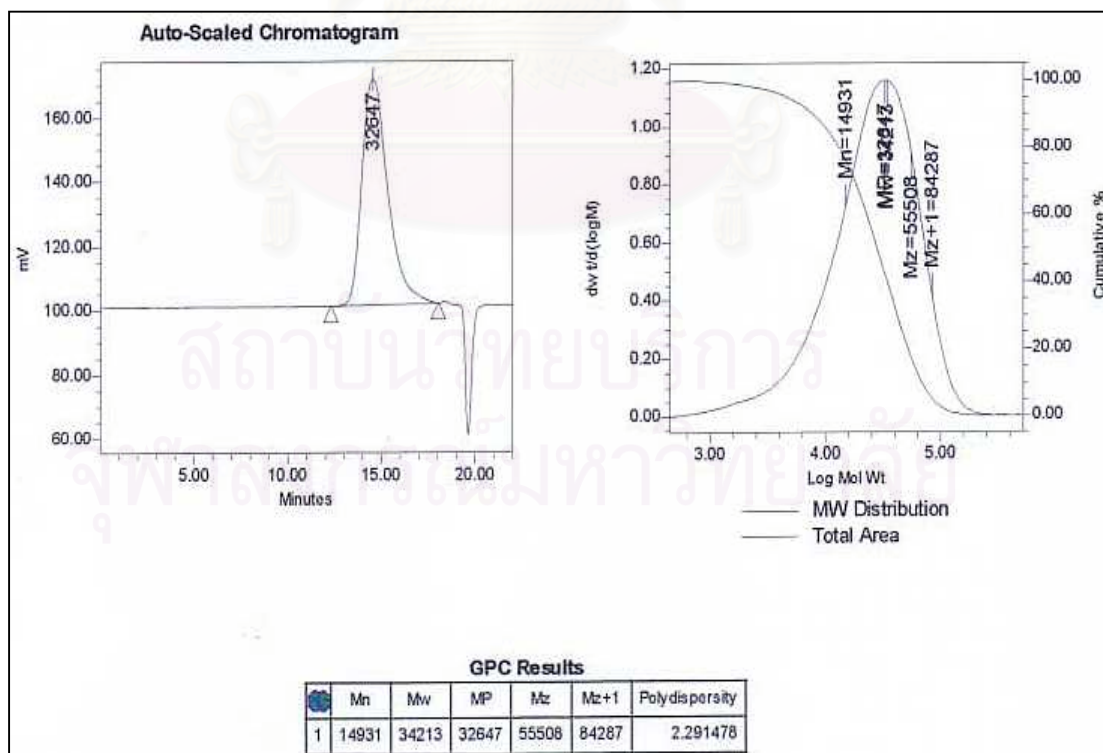

Figure 5-17 GPC chromatogram of pure PC2405 after blending by the internal mixer.

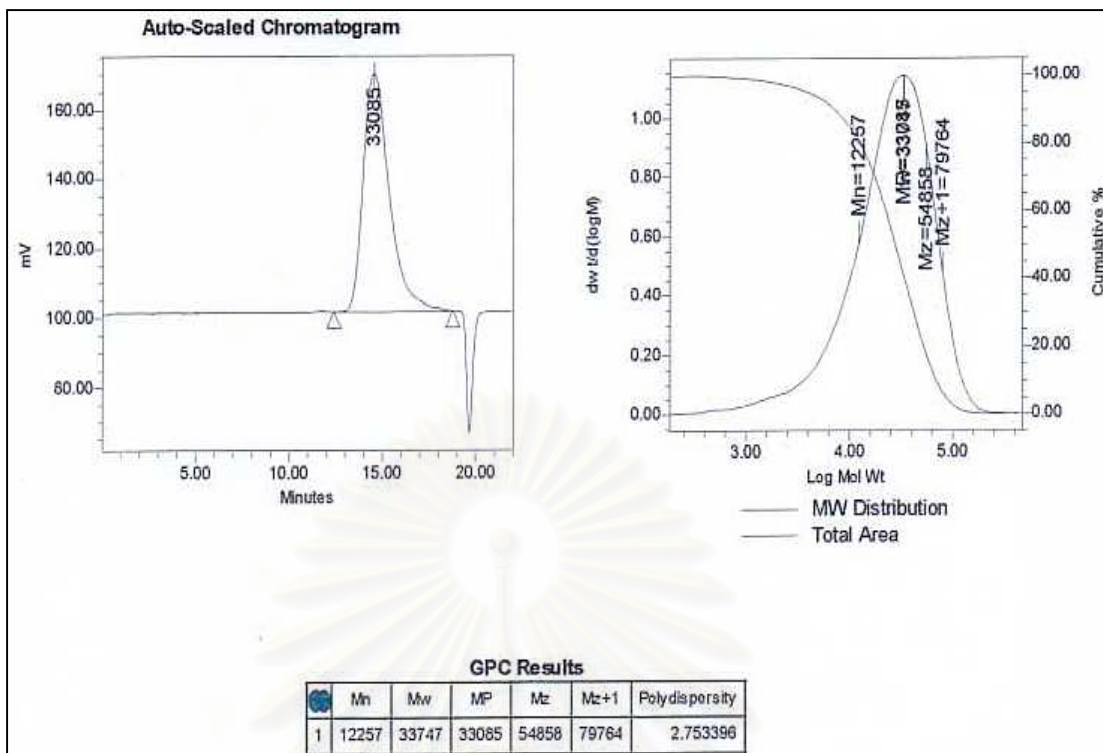

Figure 5-18 GPC chromatogram of PC2405 blended with master batch of CBC-33 after blending by the internal mixer.

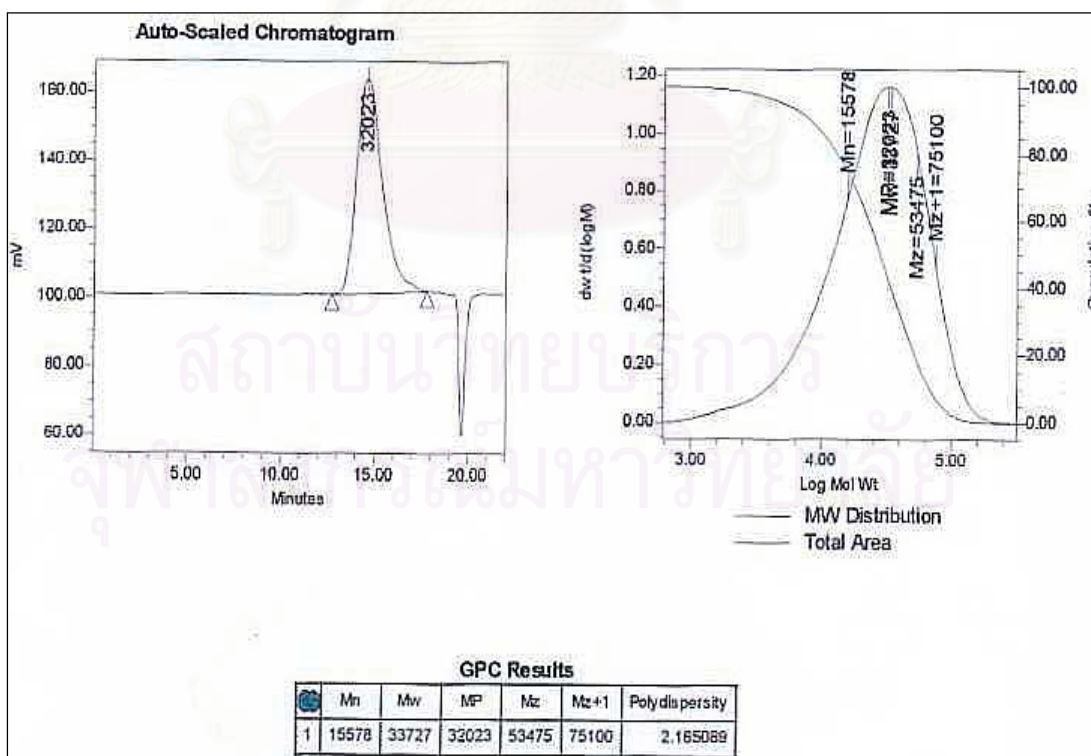

Figure 5-19 GPC chromatogram of PC2405 remix after blending by the internal mixer.

5.14 Morphology

The morphology of fracture surfaces of pure PC2405, PC2600 and their blends with master batch of CBC-33 and their remixes after blending by the internal mixer, single screw extruder and twin screw extruder were examined by SEM, as shown in figures 5-20 to 5-25. From these micrographs, fracture surfaces morphologies of the PC blend samples show no major difference from those of the pure PC. Effects of a small quantity of LCC (about 0.2% by weight) added into PC on the blends' morphologies can not be clearly seen from these series of experiments. These observations, in the case of polymer blends with low molecular weight liquid crystal (LCC), differ from morphologies of several polymer blends containing thermotropic liquid crystal polymers (LCP) where the LCP blends generally show dispersed LCP phased in the polymer matrices. LCP phases can be in droplets, elongated particles or fibrils depending upon LCP content, method of mixing and processing conditions. To further understand morphology aspects of the polymer blends having LCC, thorough examinations should be carried out on the morphology of polymer-LCC blends with various LCC contents and different processing parameters.

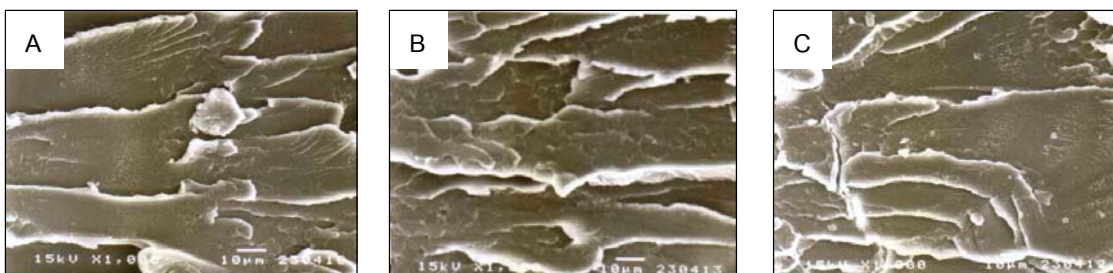

Figure 5-20 Scanning electron micrographs of fracture surfaces of PC2600 and its blends prepared by the internal mixer (A) Pure PC2600 (B) PC2600 blended with master batch of CBC-33 (C) PC2600 remix.

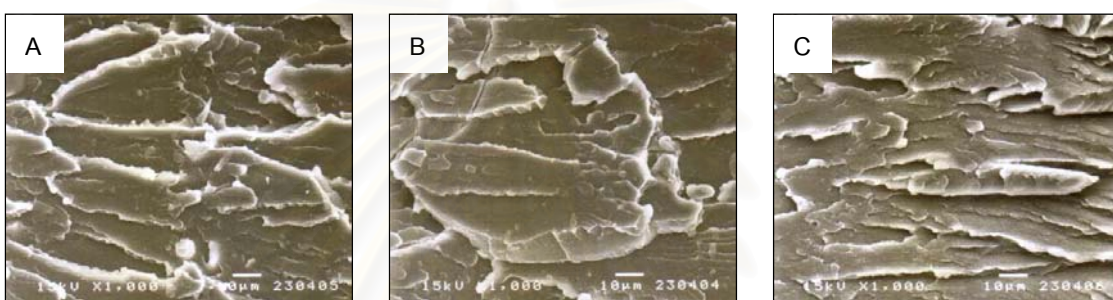

Figure 5-21 Scanning electron micrographs of fracture surfaces of PC2405 and its blends prepared by the internal mixer (A) Pure PC2405 (B) PC2405 blended with master batch of CBC-33 (C) PC2405 remix.

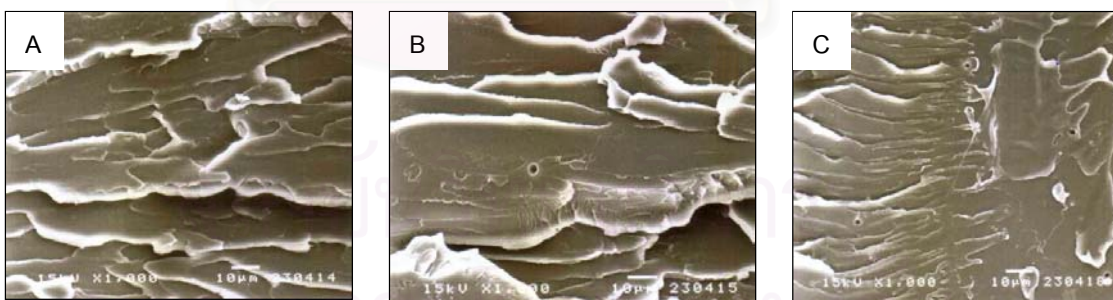

Figure 5-22 Scanning electron micrographs of fracture surfaces of PC2600 and its blends prepared by the single screw extruder (A) Pure PC2600 (B) PC2600 blended with master batch of CBC-33 (C) PC2600 remix.

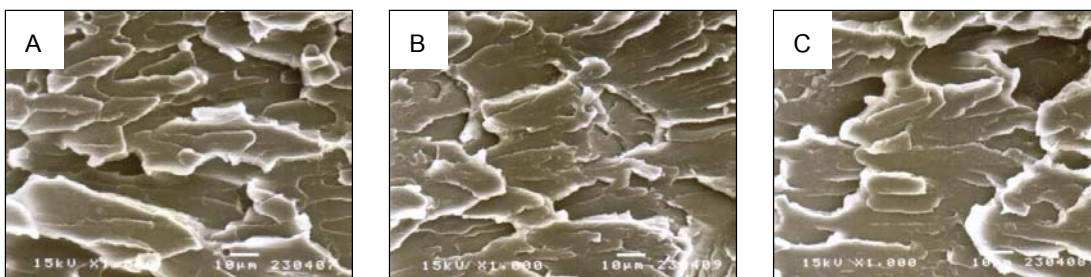

Figure 5-23 Scanning electron micrographs of fracture surfaces of PC2405 and its blends prepared by the single screw extruder (A) Pure PC2405 (B) PC2405 blended with master batch of CBC-33 (C) PC2405 remix.

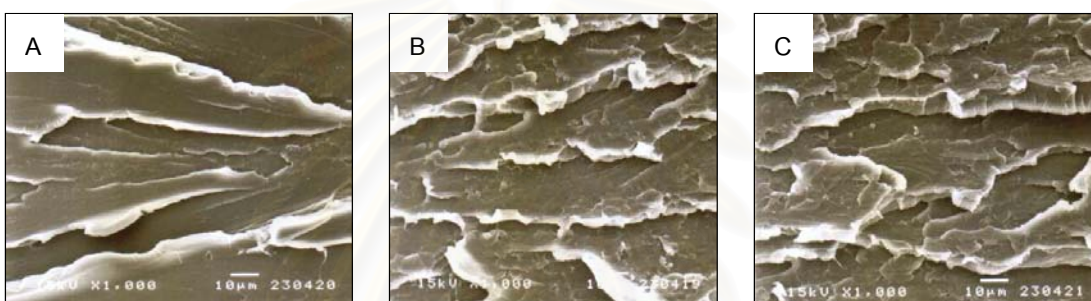

Figure 5-24 Scanning electron micrographs of fracture surfaces of PC2600 and its blends prepared by the twin screw extruder (A) Pure PC2600 (B) PC2600 blended with master batch of CBC-33 (C) PC2600 remix.

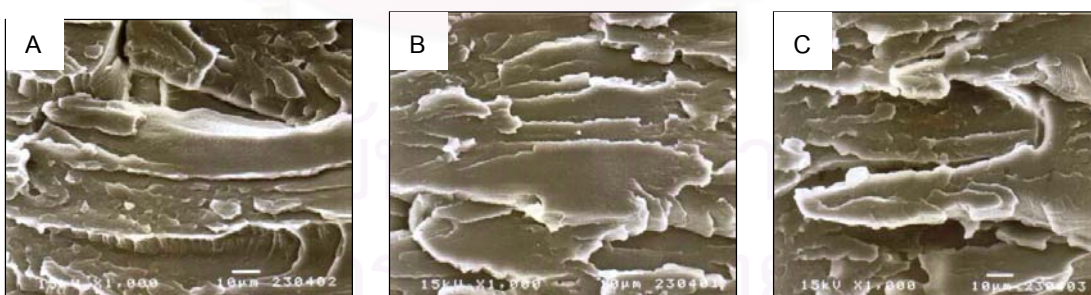

Figure 5-25 Scanning electron micrographs of fracture surfaces of PC2405 and its blends prepared by the twin screw extruder (A) Pure PC2405 (B) PC2405 blended with master batch of CBC-33 (C) PC2405 remix.

5.15 Comparison of the Torque of the Internal Mixer, Single Screw Extruder and Twin Screw Extruder Used when Melting the Polycarbonates.

Figures 5-26 and 5-27 show the torque values of the internal mixer, single screw extruder and twin screw extruder used when melting pure PC2600, PC2405 and their blends with CBC-33.

From figure 5-26, the torque value of the internal mixer used when melting the blend of PC2600 and master batch of CBC-33 was lower than the torque value of the internal mixer used when melting pure PC2600. However, in the PC2600 remix case, the torque value of the internal mixer used when melting PC2600 remix was higher than the torque value of the internal mixer used when melting pure PC2600. The torque values of the single screw extruder used when extruding the blend of PC2600 and master batch of CBC-33 and PC2600 remix were lower than the torque value of the single screw extruder used when extruding pure PC2600. The torque value of the twin screw extruder used when extruding the blend of PC2600 and master batch of CBC-33 was higher than the torque value of the twin screw extruder used when extruding pure PC2600. However, in the PC2600 remix case, the torque value of the twin screw extruder used when extruding PC2600 remix was lower than the torque value of the twin screw extruder used when extruding pure PC2600.

From figure 5-27, the torque values of the internal mixer used when melting the blend of PC2405 and master batch of CBC-33 and PC2405 remix were slightly increased when compared with the torque value of the internal mixer used when melting pure PC2405. In the case of single screw extruder and twin screw extruder, the trends of changes of the torque values were similar to the PC2600 case. The changes of torque values might be the effects of the orientation of polymer chains that occur during polymer processing.

The mixing that occur in the internal mixer could be a dispersive mixing [29] (generally involves rupture of agglomerates formed by a solid phase and separation of closely packed particles after rupture) that occurs in the vicinity of the narrow gap under the rotor wing. In the narrow-gap high-shear zone the agglomerate could be exposed to hydrodynamic forces exceed the cohesive forces that tend to break the agglomerate apart because the agglomerate freely rotates in the flow field. Agglomerate breakup could be modeled as a repetitive process. Namely, initially large agglomerate ruptures first into two equally sized fragments. Next, each fragment is considered new agglomerate of small size, which may have a chance to be broken again in a following path. The process continues until the ultimate particle size is reached that can no longer be broken by

hydrodynamic forces. Flow occurs in internal mixer that could be shear flow, which is the least efficient mixing flow.

In the extrusion, the melting is accomplished by heat transfer for the heated barrel surface and by mechanical shear heating, the extensional flow could be occurred when a material is longitudinally stretched. In extensional flows, [16] the morphology of polymer droplets in the extruded strands were seen with a progressive deformation into fibers and oriented along the flow direction by shear and elongation force during melting processing. The morphology of fractured strands of thermotropic liquid crystalline polymers (TLCPs) blended with polypropylene (PP) at various concentrations of TLCP, showed TLCP dispersed in PP matrix. It is clearly seen that the dispersed TLCP domains in 5 and 10wt%TLCP/PP strands are mostly appeared in the form of droplets. Some elongated TLCP domains are seen in the strands of 15 and 20 wt% TLCP/PP. Long TLCP fibers with bigger diameters are observed in the specimen with 30 wt% TLCP. For 50 wt% TLCP/PP blend, a coarse phase separation took place.

As seen in this study, the lowest operating torque values were observed when blending PC with LCC using the single screw extruder. It is therefore assumed that a combination of both shear and extensional flows may play a role in controlling rheological behavior of the PC-LCC blends.

More experiments should be performed to further study morphology and rheology of LCC blend with polycarbonates.

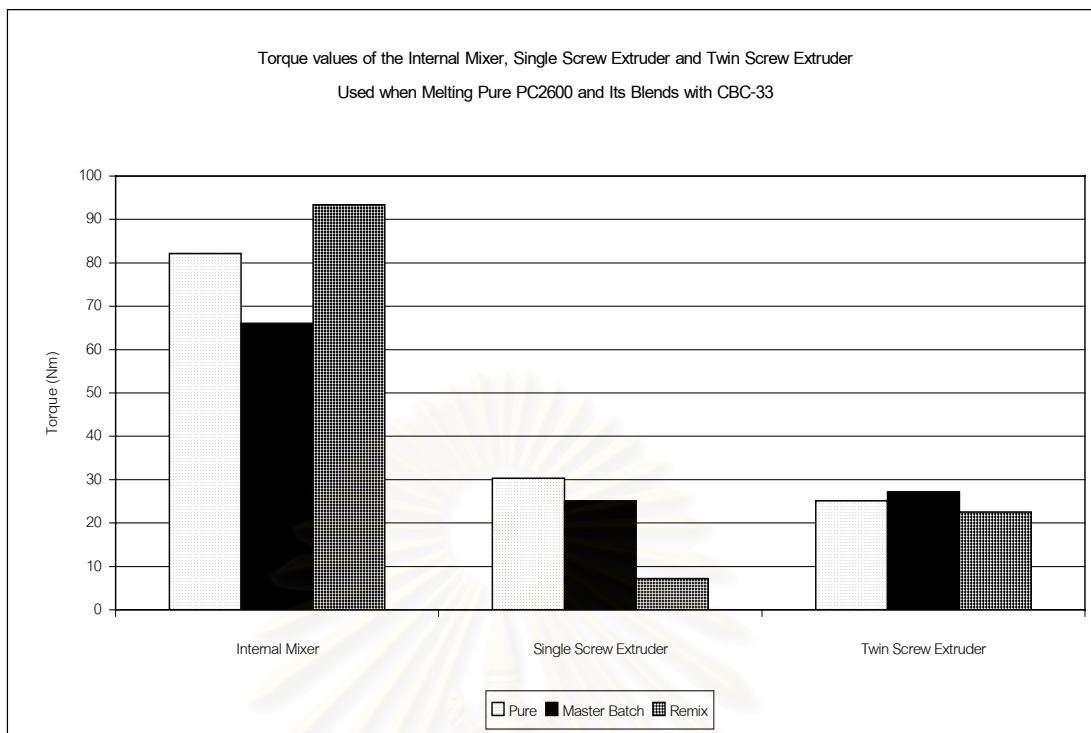

Figure 5-26 Torque values of the internal mixer, single screw extruder and twin screw extruder used when melting pure PC2600 and its blends with CBC-33.

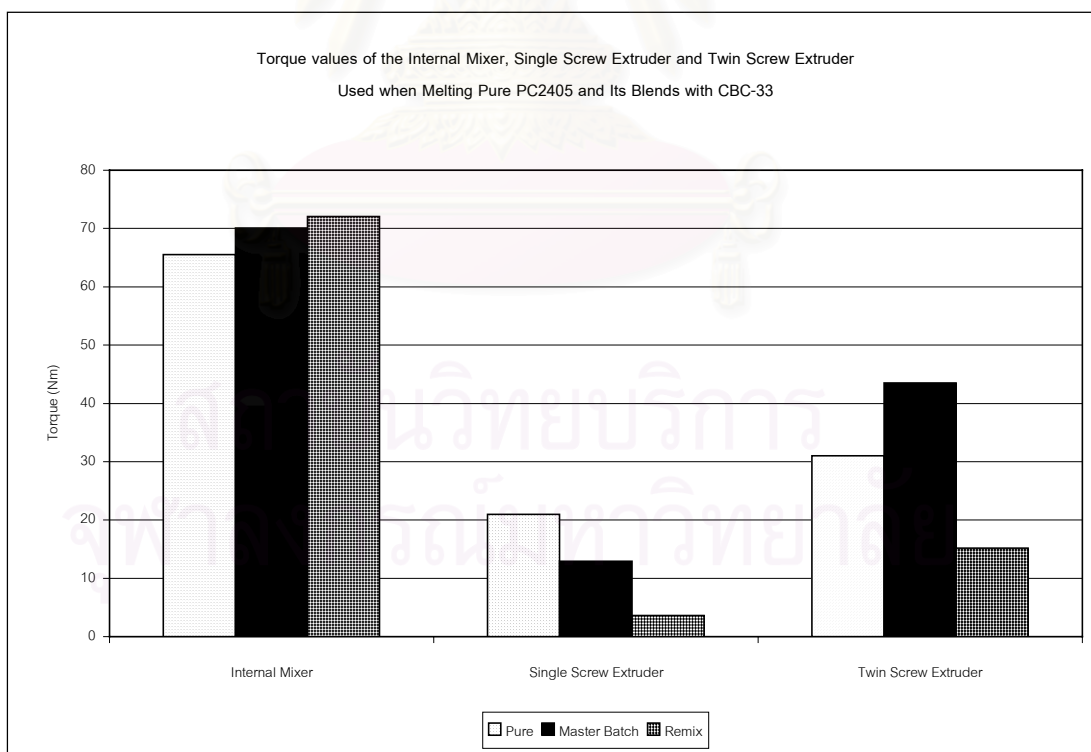

Figure 5-27 Torque values of the internal mixer, single screw extruder and twin screw extruder used when melting pure PC2405 and its blends with CBC-33.

CHAPTER 6

CONCLUSIONS AND RECOMMENDATIONS

In this chapter, the conclusions and recommendations for further studies will be focused.

6.1 Conclusions

The conclusions of this study are as follows:

1. The suitable method to disperse the LCC (CBC-33) in our polycarbonates is the master batch method. This method gradually diluted the CBC-33 and prevents the large amount agglomeration loss of the CBC-33 during the mixing according to others methods that we have tried.
2. The appropriate concentration of master batch of LCC was selected to be about 8-10% by weight.
3. The maximum reduction of the torque value of the internal mixer used when melting PC2600 and CBC-33 was reduced about 20%, when compared with pure PC2600. The torque value of the single screw extruder used when extruding the blend of PC2405 with CBC-33 was reduced about 83%. The torque value of the twin screw extruder used when extruding the blend of PC2405 with CBC-33 was reduced about 51%. This phenomenon could prove that LCC could act as a viscosity modifier of polycarbonate. Therefore, these can result in a reduction of processing temperature of polycarbonate without significantly change the glass transition temperature, which is important for polymer processing industries.
4. The reduction of torque value is highly remarkable for PC2405, which is the polycarbonate that have lower molecular weight. For example, the torque value of the single screw extruder used when extruding PC2405 remix was reduced about 83%, but the torque value of the single screw extruder used when extruding PC2600 remix was reduced about 76%
5. The additions of small amount of LCC to polycarbonate have slightly affected the mechanical properties of polycarbonates because the differences in the tensile strengths and modulus of elasticity values between pure polycarbonate and their blends with LCC are less than 10 percent for all mixing processes.
6. The additions of small amount of LCC have slight effects on morphology, thermal properties and molecular weight distributions of polycarbonate.

6.2 Recommendations for Further Studies

Since important parameters of blending LCC into the polymers include LCC content, blending or mixing methods and processing conditions, thorough studies of how these parameters influence the blends' morphology, rheology and mechanical properties should be performed. Obtained results should be integrated and justified.

From this study, the recommendations for further research are the following:

1. The appropriate amount of LCC may be different in various processing machines and it is interested to find the optimum concentration of LCC when blending polycarbonate and LCC by using the internal mixer, single screw extruder and twin screw extruder.
2. The changes in the operating condition may need different amount of the applied LCC. After we knew the optimum concentration of LCC, it might need to adjust the operating conditions of the instruments to study the effects of operating conditions on morphology, rheology and mechanical properties of polymer blend.



สถาบันวิทยบริการ
จุฬาลงกรณ์มหาวิทยาลัย

REFERENCES

1. McKelvey, James. M. Polymer Processing. New York: John Wiley and Sons, 1962.
2. Baird, Ronald. J. and Baird, David. T. Industrial Plastics. New York: The Goodheart-Willcox, 1982.
3. Lutz, John. T. Jr. and Grossman, Richard. F. Polymer Modifiers and Additives. New York: Marcel Dekker, 2001.
4. Suraphan Powanusorn. Application of low molar mass thermotropic liquid crystals as an additive for polymers. Master's Thesis, Department of Chemical Engineering, Graduate School, Chulalongkorn University, 2000.
5. Nobile, M. R. Amendola, E. and Nicolias, L. Physical properties of blends of polycarbonate and a liquid crystalline copolyester. Polymer Engineering and Science. 29 (1989): 244-257.
6. Buckley, A. Conciatori, A. B. and Calundamm, G.W. U.S. Patent. 4,434,262, 1984.
7. Siegmann, A. Dagan, A. and Kenig, S. Polyblends containing a liquid crystalline polymer. Polymer. 26 (1985): 1325-1330.
8. Blizard, K. G. and Baird, D. G. The morphology and rheology of polymer blends containing a liquid crystalline copolyester. Polymer Engineering and Science. 27 (1987): 653-662.
9. Tariq, M. Malik. Pierre, J. Carreau and Nathalie Chapleau. Characterization of liquid crystalline polyester polycarbonate blends. Polymer Engineering and Science. 29 (1989): 600-608.
10. Cottis, S. Chin, H. Shiau, W. and Shopland, D. U.S. Patent. 5,262,473,1993.
11. Beery, D. Kenig, S. and Siegmann, A. Structure development during flow of polyblends containing liquid crystalline polymers. Polymer Engineering and Science. 31 (1991): 451-466.
12. Beery, D. Kenig, S. and Siegmann, A. Shear and elongational viscosities of a thermotropic liquid crystalline polymer and its blend with polycarbonate. Polymer Engineering and Science. 32 (1992): 14-19.
13. Lin, Y. C. Lee, H. W. and Winter, H. H. Miscibility and viscoelastic properties of blends of a liquid-crystalline polymer and poly (ethylene terephthalate). Polymer. 34 (1993): 4703-4709.
14. He, Jiasong and Bu, Wensheng. Microstructure formation in polyblends containing liquid crystalline polymers. Polymer. 35 (1994): 5061-5066.

15. Anchana Chuenchaokit. Effects of thermotropic liquid crystal on properties of polycarbonates. Master's Thesis, Department of Chemical Engineering, Graduate School, Chulalongkorn University, 1998.
16. Sayant Saengsuwan and Sauvarop Bualek-Limcharoen. Thermotropic liquid crystalline polymer (Rodrun LC5000)/polypropylene in situ composite films: rheology, morphology, molecular orientation and tensile properties. Polymer. Available online 4 April 2003.
17. The Editor of Modern Plastics Encyclopedia. Guide to Plastics'78: Property and Specification Charts. New York: McGraw-Hill, 1977.
18. Netfirms. Introduction to Liquid Crystals. Available from:
<http://adminnet.eng.ox.ac.uk/lc/research/introf.html>.
19. Netfirms. Polymer Liquid Crystals. Available from:
<http://plc.cwru.edu/tutorial/enhanced/files/lindex.html>.
20. Gray, G. W. Molecular structure and the properties of liquid crystals. London: Academic Press, 1962.
21. Demus, D. Goodby, J. Gray, G.W. Spiess, H. W. and Vill, V. Handbook of Liquid Crystals. Vol.2A: Low Molecular Weight Liquid Crystals I. New York: Wiley-VCH, 1998.
22. Cifferri, A. Krigbaum, W. R. and Meyer, Robert B. Polymer liquid crystal. London: Academic Press, 1982.
23. Cheremisinoff, Nicholas P. An introduction to polymer rheology and processing. Florida: CRC Press, 1992.
24. Netfirms. The Injection Molding Machine. Available from:
http://www.scudu.scu.edu/cmdoc/dg_doc/develop/process/control/b1000001.html.
25. Merck. Information of Licristal. 1985.
26. Paveena Meesap. Preliminary study of static light scattering behaviors and morphologies of polymer blend between high-density polyethylene and linear low-density polyethylene. Master's Thesis, Department of Chemical Engineering, Graduate School, Chulalongkorn University, 2002.
27. Morton, D.H.-Sones. Polymer Processing. London: Chapman&Hall, 1989.
28. Rosato, Dominick. V., Rosato, Donald. V. and Rosato, Marlene. G. Injection molding handbook. 3rd edition, Boston: Kluwer Academic, 2000.
29. Rauwendaal, C. Mixing in Polymer Processing. New York: Marcel Dekker, 1991.
30. Mendenhall, W. and Sincich, T. A Second Course in Statistic: Regression Analysis. 5th edition, New Jersey: Prentice-Hall International, 1996.

APPENDIX A

ERROR ANALYSIS

Most experimental data in this thesis are reported with the error bar of 95% confidence. It should be noted that the 95% confidence interval or 0.95 confidence coefficient in fact means if it is assumed that the distribution is the normal probability distribution, 95% of data fall within this region. The value can be defined as;

$$t_{.025} \left(\frac{\sigma}{\sqrt{n}} \right)$$

Where $t_{.025}$ is the standard normal value at the degree of freedom of (n-1), as can be seen in figure A-1.

σ is standard deviation

n is number of data

For example

From tensile test, it appears that the standard deviation of tensile strength of pure PC2600 is 4.53 and the number of specimen is six. At the column of $t_{.025}$ and the degree of freedom of 5 in figure A-1, it gives 2.571. The value of 95% confidence therefore is 4.75.

สถาบันวิทยบริการ
จุฬาลงกรณ์มหาวิทยาลัย

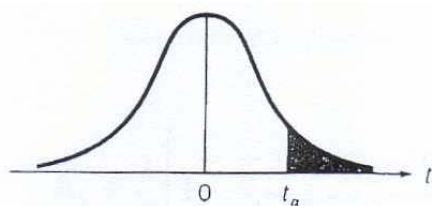

ν	$t_{.100}$	$t_{.050}$	$t_{.025}$	$t_{.010}$	$t_{.005}$	$t_{.001}$	$t_{.0005}$
1	3.078	6.314	12.706	31.821	63.657	318.31	636.62
2	1.886	2.920	4.303	6.965	9.925	22.326	31.598
3	1.638	2.353	3.182	4.541	5.841	10.213	12.924
4	1.533	2.132	2.776	3.747	4.604	7.173	8.610
5	1.476	2.015	2.571	3.365	4.032	5.893	6.869
6	1.440	1.943	2.447	3.143	3.707	5.208	5.959
7	1.415	1.895	2.365	2.998	3.499	4.785	5.408
8	1.397	1.860	2.306	2.896	3.355	4.501	5.041
9	1.383	1.833	2.262	2.821	3.250	4.297	4.781
10	1.372	1.812	2.228	2.764	3.169	4.144	4.587
11	1.363	1.796	2.201	2.718	3.106	4.025	4.437
12	1.356	1.782	2.179	2.681	3.055	3.930	4.318
13	1.350	1.771	2.160	2.650	3.012	3.852	4.221
14	1.345	1.761	2.145	2.624	2.977	3.787	4.140
15	1.341	1.753	2.131	2.602	2.947	3.733	4.073
16	1.337	1.746	2.120	2.583	2.921	3.686	4.015
17	1.333	1.740	2.110	2.567	2.898	3.646	3.965
18	1.330	1.734	2.101	2.552	2.878	3.610	3.922
19	1.328	1.729	2.093	2.539	2.861	3.579	3.883
20	1.325	1.725	2.086	2.528	2.845	3.552	3.850
21	1.323	1.721	2.080	2.518	2.831	3.527	3.819
22	1.321	1.717	2.074	2.508	2.819	3.505	3.792
23	1.319	1.714	2.069	2.500	2.807	3.485	3.767
24	1.318	1.711	2.064	2.492	2.797	3.467	3.745
25	1.316	1.708	2.060	2.485	2.787	3.450	3.725
26	1.315	1.706	2.056	2.479	2.779	3.435	3.707
27	1.314	1.703	2.052	2.473	2.771	3.421	3.690
28	1.313	1.701	2.048	2.467	2.763	3.408	3.674
29	1.311	1.699	2.045	2.462	2.756	3.396	3.659
30	1.310	1.697	2.042	2.457	2.750	3.385	3.646
40	1.303	1.684	2.021	2.423	2.704	3.307	3.551
60	1.296	1.671	2.000	2.390	2.660	3.232	3.460
120	1.289	1.658	1.980	2.358	2.617	3.160	3.373
∞	1.282	1.645	1.960	2.326	2.576	3.090	3.291

Figure A-1 Critical values for student

From Mendenhall, W. and Sincich, T., "A Second Course in Statistics: Regression Analysis", 5th edition. New Jersey: Prentice-Hall International, 1996.

APPENDIX B

RAW DATA OF MECHANICAL PROPERTY

Table B-1 Tensile strengths of PC2600 and its blends with CBC-33 prepared by the internal mixer.

Sample no.	Tensile Strength of Pure PC2600 (MPa)	Tensile Strength of PC2600+MB (MPa)	Tensile Strength of PC2600 Remix (MPa)
1	36.7	34.0	39.9
2	44.4	39.6	33.2
3	39.5	38.5	33.8
4	34.7	36.5	32.4
5	34.2	34.4	46.9
6	44.0	38.9	36.2

Table B-2 Tensile strengths of PC2405 and its blends with CBC-33 prepared by the internal mixer.

Sample no.	Tensile Strength of Pure PC2405 (MPa)	Tensile Strength of PC2405+MB (MPa)	Tensile Strength of PC2405 Remix (MPa)
1	40.3	43.9	51.8
2	48.8	31.9	28.7
3	39.6	32.8	51.3
4	23.2	33.6	24.4
5	47.8	33.4	38.7
6	40.1	49.3	49.8

Table B-3 Tensile strengths of PC2600 and its blends with CBC-33 prepared by the single screw extruder.

Sample no.	Tensile Strength of Pure PC2600 (MPa)	Tensile Strength of PC2600+MB (MPa)	Tensile Strength of PC2600 Remix (MPa)
1	34.7	38.6	38.2
2	32.5	42.4	36.7
3	35.1	39.2	46.3
4	36.0	40.9	36.1
5	41.5	35.5	37.2
6	37.4	39.1	32.9

Table B-4 Tensile strengths of PC2405 and its blends with CBC-33 prepared by the single screw extruder.

Sample no.	Tensile Strength of Pure PC2405 (MPa)	Tensile Strength of PC2405+MB (MPa)	Tensile Strength of PC2405 Remix (MPa)
1	32.3	40.4	37.8
2	34.8	41.9	42.9
3	36.7	36.0	36.5
4	38.4	37.1	36.3
5	37.6	45.6	32.3
6	44.4	39.3	47.8

สถาบันวิทยบริการ
จุฬาลงกรณ์มหาวิทยาลัย

Table B-5 Tensile strengths of PC2600 and its blends with CBC-33 prepared by the twin screw extruder.

Sample no.	Tensile Strength of Pure PC2600 (MPa)	Tensile Strength of PC2600+MB (MPa)	Tensile Strength of PC2600 Remix (MPa)
1	35.0	33.6	35.0
2	31.6	35.1	40.1
3	36.4	33.4	36.4
4	28.8	40.0	34.9
5	40.8	39.1	37.2
6	37.6	40.1	38.4

Table B-6 Tensile strengths of PC2405 and its blends with CBC-33 prepared by the twin screw extruder.

Sample no.	Tensile Strength of Pure PC2405 (MPa)	Tensile Strength of PC2405+MB (MPa)	Tensile Strength of PC2405 Remix (MPa)
1	33.8	42.2	35.8
2	37.0	47.2	35.7
3	49.2	45.7	29.0
4	32.8	36.8	46.4
5	40.8	40.1	53.6
6	37.6	34.4	44.2

สถาบันวิทยบริการ
จุฬาลงกรณ์มหาวิทยาลัย

Table B-7 Modulus of elasticity values of PC2600 and its blends with CBC-33 prepared by the internal mixer.

Sample no.	Modulus of Elasticity of Pure PC2600 (MPa)	Modulus of Elasticity of PC2600+MB (MPa)	Modulus of Elasticity of PC2600 Remix (MPa)
1	814	776	654
2	726	808	698
3	685	788	642
4	809	802	702
5	707	753	777
6	749	798	728

Table B-8 Modulus of elasticity values of PC2405 and its blends with CBC-33 prepared by the internal mixer.

Sample no.	Modulus of Elasticity of Pure PC2405 (MPa)	Modulus of Elasticity of PC2405+MB (MPa)	Modulus of Elasticity of PC2405 Remix (MPa)
1	754	724	669
2	710	758	726
3	669	768	681
4	718	745	730
5	670	750	743
6	673	799	737

สถาบันวิทยบริการ
จุฬาลงกรณ์มหาวิทยาลัย

Table B-9 Modulus of elasticity values of PC2600 and its blends with CBC-33 prepared by the single screw extruder.

Sample no.	Modulus of Elasticity of Pure PC2600 (MPa)	Modulus of Elasticity of PC2600+MB (MPa)	Modulus of Elasticity of PC2600 Remix (MPa)
1	791	790	756
2	781	795	708
3	753	767	814
4	789	779	812
5	747	782	729
6	742	769	709

Table B-10 Modulus of elasticity values of PC2405 and its blends with CBC-33 prepared by the single screw extruder.

Sample no.	Modulus of Elasticity of Pure PC2405 (MPa)	Modulus of Elasticity of PC2405+MB (MPa)	Modulus of Elasticity of PC2405 Remix (MPa)
1	667	800	666
2	817	774	744
3	748	759	634
4	705	722	730
5	703	724	642
6	690	800	773

สถาบันวิทยบริการ
จุฬาลงกรณ์มหาวิทยาลัย

Table B-11 Modulus of elasticity values of PC2600 and its blends with CBC-33 prepared by the twin screw extruder.

Sample no.	Modulus of Elasticity of Pure PC2600 (MPa)	Modulus of Elasticity of PC2600+MB (MPa)	Modulus of Elasticity of PC2600 Remix (MPa)
1	736	751	746
2	779	784	806
3	743	779	779
4	721	753	766
5	754	764	825
6	718	744	779

Table B-12 Modulus of elasticity values of PC2405 and its blends with CBC-33 prepared by the twin screw extruder.

Sample no.	Modulus of Elasticity of Pure PC2405 (MPa)	Modulus of Elasticity of PC2405+MB (MPa)	Modulus of Elasticity of PC2405 Remix (MPa)
1	775	810	687
2	749	717	740
3	663	688	724
4	753	771	718
5	698	775	747
6	749	751	665

สถาบันวิทยบริการ
จุฬาลงกรณ์มหาวิทยาลัย

VITA

Miss Supaluk Khunprasert was born in Chachoengsao, Thailand in October 8, 1976. She received the Bachelor Degree of Engineering in Chemical Engineering from the Department of Chemical Engineering, King Mongkut's Institute of Technology Ladkrabang in 1999. She entered the Master Degree of Engineering in Chemical Engineering Program at Chulalongkorn University in 2000.



สถาบันวิทยบริการ
จุฬาลงกรณ์มหาวิทยาลัย