

CHAPTER IV

INTEGRAL GEOMETRY OVER SETS OF CIRCLES, SETS OF PAIRS OF CIRCLES AND SETS OF PAIRS OF KINEMATICS.

Section 4.1 Integral Geometry Over Sets of Circles.

4.1.1 Density for sets of circles invariant under the group of Euclidean motions

Let C be a set of circles B . A circle B in the plane can be determined by the three coordinates x, y, r where (x, y) is its center and r is its radius. We want to determine all densities which will make $m(C)$ invariant under the group of Euclidean motions \mathcal{M} . Let $g \in \mathcal{M}$ and represented by the equation

$$(4.1) \quad \begin{cases} x^* = a + x \cos \theta + y \sin \theta \\ y^* = b - x \sin \theta + y \cos \theta \\ r^* = r \end{cases}$$

i.e. we want

$$\iiint_C f(x, y, r) \, dx \, dy \, dr = \iiint_{C^*} f(x^*, y^*, r^*) \, dx^* \, dy^* \, dr^* \quad \forall g \in \mathcal{M}$$

On the other hand, according to (4.1) we have

$$\iiint_{C^*} f(x^*, y^*, r^*) \, dx^* \, dy^* \, dr^* = \iiint_C f(x^*, y^*, r^*) \, dx \, dy \, dr$$

because

$$\frac{\partial(x^*, y^*, r^*)}{\partial(x, y, r)} = \begin{vmatrix} \cos \theta & \sin \theta & 0 \\ -\sin \theta & \cos \theta & 0 \\ 0 & 0 & 1 \end{vmatrix} = 1$$

From the last two equalities we obtain

$$\iiint_C f(x, y, r) \, dx \, dy \, dr = \iiint_C f(x^*, y^*, r^*) \, dx \, dy \, dr \quad \forall \text{ domain } C$$

If this equality holds for any set C , it must be true that

$$f(x, y, r) = f(x^*, y^*, r^*)$$

this implies that $f(x, y, r)$ is a function of r only.

For simplicity we choose this function of r to be constant and to normalize we take it to be 1, we have

The measure of a set C of circles $B(x, y, r)$ is defined by

$$m(C) = \iiint_C dx \, dy \, dr$$

Up to a constant factor, this measure is the only one which is invariant under the group of motions \mathcal{M} .

The differential form under the integral sign is called the density for sets of circles and we will represent it by dB .

4.1.2 Density for sets of circles invariant under group of conformal transformations.

Let C be a set of circles B whose its coordinates are x, y and r . We want to determine all densities which will make $m(C)$ invariant under the group of conformal transformations \mathcal{G} .

Let $h \in \mathcal{G}$ and represented by the equation

$$(4.2) \quad \begin{cases} x^* = a + kx \cos \theta + ky \sin \theta \\ y^* = b - kx \sin \theta + ky \cos \theta \\ r^* = kr \end{cases} \quad \text{where } k \in \mathbb{R} \text{ and be positive.}$$

i.e. we want

$$\iiint_C f(x, y, r) dx dy dr = \iiint_{C^*} f(x^*, y^*, r^*) dx dy dr \quad \forall h \in \mathcal{G}$$

On the other hand, according to (4.2) we have

$$\iiint_{C^*} f(x^*, y^*, r^*) dx dy dr = \iiint_C k^3 f(x^*, y^*, r^*) dx dy dr$$

because

$$\frac{\partial (x^*, y^*, r^*)}{\partial (x, y, r)} = \begin{vmatrix} k \cos \theta & k \sin \theta & 0 \\ -k \sin \theta & k \cos \theta & 0 \\ 0 & 0 & k \end{vmatrix} = k^3$$

From the last two equalities we obtain

$$\iiint_C f(x, y, r) dx dy dr = \iiint_C k^3 f(x^*, y^*, r^*) dx dy dr .$$

If this equality holds for any set C , it must be true that

$$f(x, y, r) = k^3 f(x^*, y^*, r^*)$$

this implies that $f(x, y, r)$ is a function of r only.

$$\text{i. e.} \quad f(r) = k^3 f(kr)$$

$$\text{or} \quad f(kr) = \frac{1}{k^3} f(r)$$

we want to find $f(r)$ which satisfies the last equality. To find this, fix $r \in (0, \infty)$ we have

$$\begin{aligned} f(r) &= f(r \cdot 1) \\ &= \frac{f(1)}{r^3} \\ &= \frac{\text{constant}}{r^3} \end{aligned}$$

For simplicity we choose this constant to be 1, so the measure of a set C of circles $B(x, y, r)$ is defined by

$$m(C) = \iiint_C \frac{1}{r^3} dx dy dr$$

The differential form under the integral sign is called the density for set of circles invariant under group of conformal transformations. We will represent $\frac{dx dy dr}{r^3}$ by dB .

4.1.3 Theorem : Let K be a fixed circle of radius r and center at the origin. Let X be the set-of circles B whose centers are in K and B intersect K . Then by using density in 4.1.1

$$\int_X dB = \frac{4}{3} \pi r^3$$

Proof:

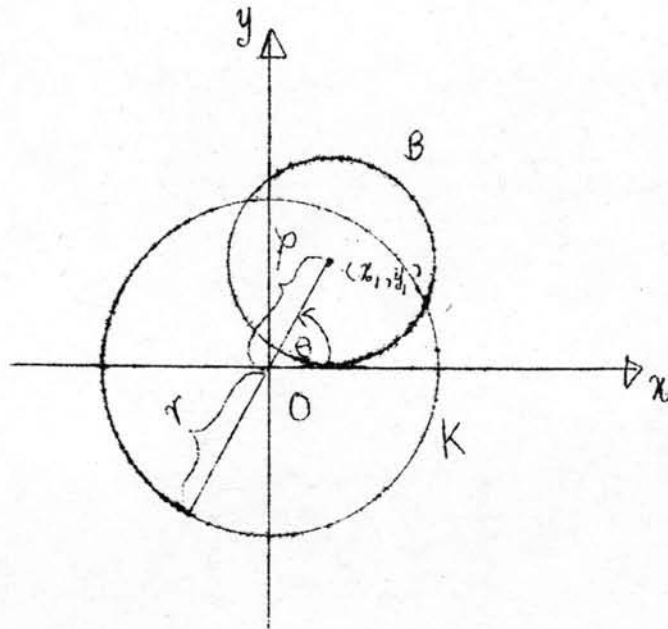

Figure 26

Let B be a circle of radius r_1 and center at (x_1, y_1)

shown in figure 26

According to 4.1.1 we have

$$dB = dx_1 dy_1 dr_1$$

so

$$\int_X dB = \iiint_X dx_1 dy_1 dr_1$$

Transform to polar coordinate (ρ, θ) we have

$$dx_1 dy_1 = \rho d\rho d\theta$$

therefore

$$\begin{aligned} \int_X dB &= \iiint_X \rho d\rho d\theta dr_1 \\ &= \iiint_X \left[\int_{r-\rho}^{r+\rho} \rho dr_1 \right] d\rho d\theta \\ &= \int \left[\int_0^r 2\rho d\rho \right] d\theta \\ &= 2 \int \left(\frac{\rho^3}{3} \Big|_0^r \right) d\theta \\ &= \frac{2}{3} \int_0^{2\pi} r^3 d\theta \\ &= \frac{4}{3} \pi r^3 \end{aligned}$$

Q.E.D

4.1.4 Theorem : Let A be a fixed angle and X be the set of circles B of radius r such that $0 \leq r \leq a$ which intersect this angle. Then by using density in 4.1.1

$$\int_X dB = \left(\cot A + \frac{1}{\sin A} + \frac{\pi}{2} + \frac{A}{2} \right) \frac{a^3}{3}$$

Proof :

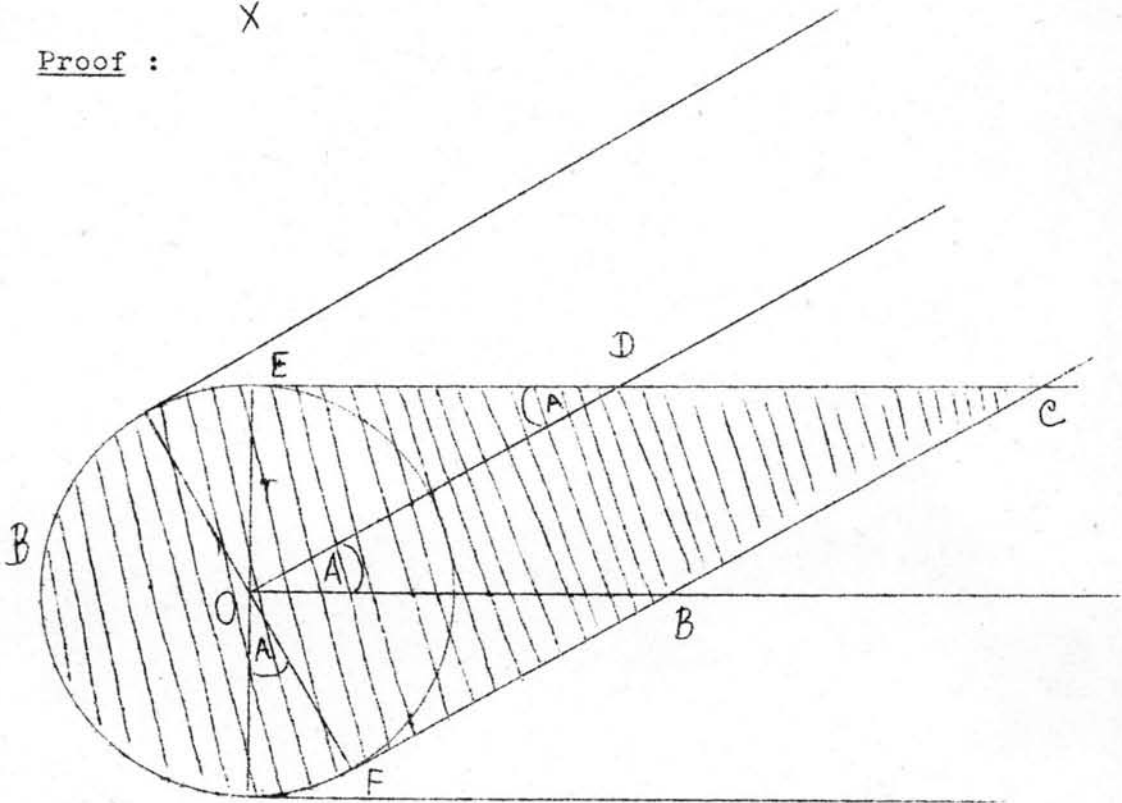

Figure 27

Let (x, y) be the center of circle B and radius r .

We see that, centers of the set of circles B which intersect both sides of angle A lie in the shaded area say U .

area of U = area of semicircle of radius r + area of segment
of angle Λ and radius r + area of
 Δ ODE + area of Δ OFB + area of \square OBCD.
(see Figure 27)

$$\begin{aligned} \text{area of } \square \text{ OBCD} &= OD \times OE \\ &= \frac{r}{\sin \Lambda} \times r \\ &= \frac{r^2}{\sin \Lambda} \end{aligned}$$

$$\begin{aligned} \text{area of } \Delta \text{ ODE} &= \text{area of } \Delta \text{ OFB} = \frac{1}{2} \times DE \times OE \\ &= \frac{1}{2} \times r \cot \Lambda \times r \\ &= \frac{r^2 \cot \Lambda}{2} \end{aligned}$$

therefore

$$\text{area of U} = \frac{\pi r^2}{2} + \frac{1}{2} r^2 \Lambda + r^2 \cot \Lambda + \frac{r^2}{\sin \Lambda}$$

From density in 4.1.1 we get

$$\begin{aligned} \int_X dB &= \int_X dx dy dr \\ &= \int_0^a \left[\int_{(r,y) \in U} dx dy \right] dr \\ &= \int_0^a \left(\frac{\pi r^2}{2} + \frac{r^2 \Lambda}{2} + r^2 \cot \Lambda + \frac{r^2}{\sin \Lambda} \right) dr \end{aligned}$$

$$= \left(\cot A + \frac{1}{\sin A} + \frac{\pi}{2} + \frac{A}{2} \right) \frac{r^3}{3} \Big|_0^a$$

Thus

$$\int_X dB = \left(\cot A + \frac{1}{\sin A} + \frac{\pi}{2} + \frac{A}{2} \right) \frac{a^3}{3}$$

Q.E.D.

4.1.5 Corollary : Let A be a fixed angle and X be the set of circles B of radius r such that $m \leq r \leq n$ which intersect this angle. Then by using density in 4.1.2

$$\int_X dB = \left(\cot A + \frac{1}{\sin A} + \frac{\pi}{2} + \frac{A}{2} \right) \ln \frac{n}{m} \quad (m > 0)$$

Proof : Let (x, y) be the center of circle B and radius r . The same as Theorem 4.1.4, centers of the set of circles B which intersect both sides of angle A lie in the area U .

From density in 4.1.2 we get

$$\begin{aligned} \int_X dB &= \int_X \frac{dx dy dr}{r^3} \\ &= \int \frac{1}{r^3} \left[\int_{(x,y) \in U} dx dy \right] dr \\ &= \int_m^n \frac{1}{r} \left(\cot A + \frac{1}{\sin A} + \frac{\pi}{2} + \frac{A}{2} \right) dr \end{aligned}$$

therefore

$$\int_X dB = \left(\cot A + \frac{1}{\sin A} + \frac{\pi}{2} + \frac{A}{2} \right) \ln \frac{n}{m}$$

Q.E.D.

Section 4.2 Integral Geometry Over Sets of Pairs of Circles.

4.2.1 Density for pairs of circles.

A pair of circles $B_1(x_1, y_1, r_1)$, $B_2(x_2, y_2, r_2)$ may be determined by the six coordinates $x_1, y_1, r_1, x_2, y_2, r_2$. It may also be determined by the coordinates p, φ of the straight line l determined by $(x_1, y_1), (x_2, y_2)$ together with the directed distances t_1, t_2 from $(x_1, y_1), (x_2, y_2)$ to the foot of the perpendicular from origin O to l and together with r_1, r_2 . We want to express the product $dB_1 dB_2 = dx_1 dy_1 dr_1 dx_2 dy_2 dr_2$ where this density is invariant under group of transformation in (4.1) by means of the coordinates $p, \varphi, t_1, t_2, r_1, r_2$.

From (3.29) we have

$$dP_1 dP_2 = dx_1 dy_1 dx_2 dy_2 = |t_2 - t_1| dG dt_1 dt_2$$

therefore

$$(4.3) \quad dB_1 dB_2 = |t_2 - t_1| dG dt_1 dt_2 dr_1 dr_2$$

Similarly, we can express the density for pair of circles which is invariant under group of conformal motion in (4.2) by means of the coordinates $p, \varphi, t_1, t_2, r_1, r_2$. That is

$$(4.4) \quad dB_1 dB_2 = \frac{1}{r_1^3 r_2^3} |t_2 - t_1| dG dt_1 dt_2 dr_1 dr_2 \cdot$$

4.2.2 Theorem : Let K be a convex curve and X be the set of pairs of distinct circles B_1 and B_2 such that their centers are contained in K and their distance is r where $r \geq 0$. Assume that B_1 and B_2 not contain K and let l be the straight line through the centers of B_1 and B_2 and Δ be the length of the chord determined by l and K . Then by using the density in (4.3)

$$\int_X r dB_1 dB_2 = \frac{11}{1440} \int_{l \cap K \neq \emptyset} \Delta^6 dG$$

Proof : Choose a fixed rectangular coordinate system so that the convex curve K lies in the first quadrant.

Let B_1, B_2 be a pair of distinct circles whose centers at (x_1, y_1) and (x_2, y_2) and radius of B_1 and B_2 is r_1 and r_2 respectively. Let b and a signify the values of t corresponding to the end points of Δ , so that $b - a = \Delta$

To prove this, we have 3 possible cases :

case 1 Let $X_1 = \left\{ (B_1, B_2) \in X \mid \begin{array}{l} \text{exactly one of the intersection} \\ \text{points between } B_1 \text{ and } l \text{ is contained in } K \text{ and the other has } t \\ \text{coordinate } < a \end{array} \right\}$. This set is shown in figure 28.

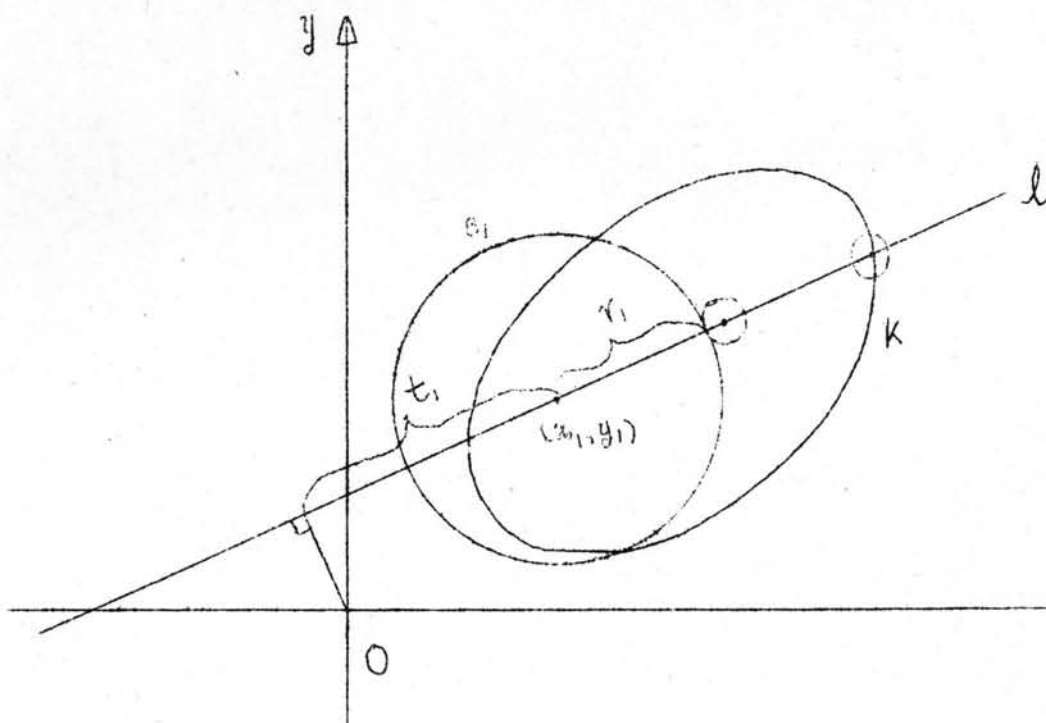

Figure 28

In this case we have $r = t_2 - t_1 - r_1 - r_2$, if we

fix t_1, r_1, r_2, l then t_2 varies from $t_1 + r_1 + r_2$ to b

fix t_1, r_1, l then r_2 varies from 0 to $b - t_1 - r_1$

fix l, r_1 then t_1 varies from a to $a + r_1$

fix l then r_1 varies from 0 to Δ

case 2 Let $X_2 = \left\{ (B_1, B_2) \in X \mid \text{both of the intersection points between } B_1 \text{ and } l \text{ are contained in } K \right\}$.

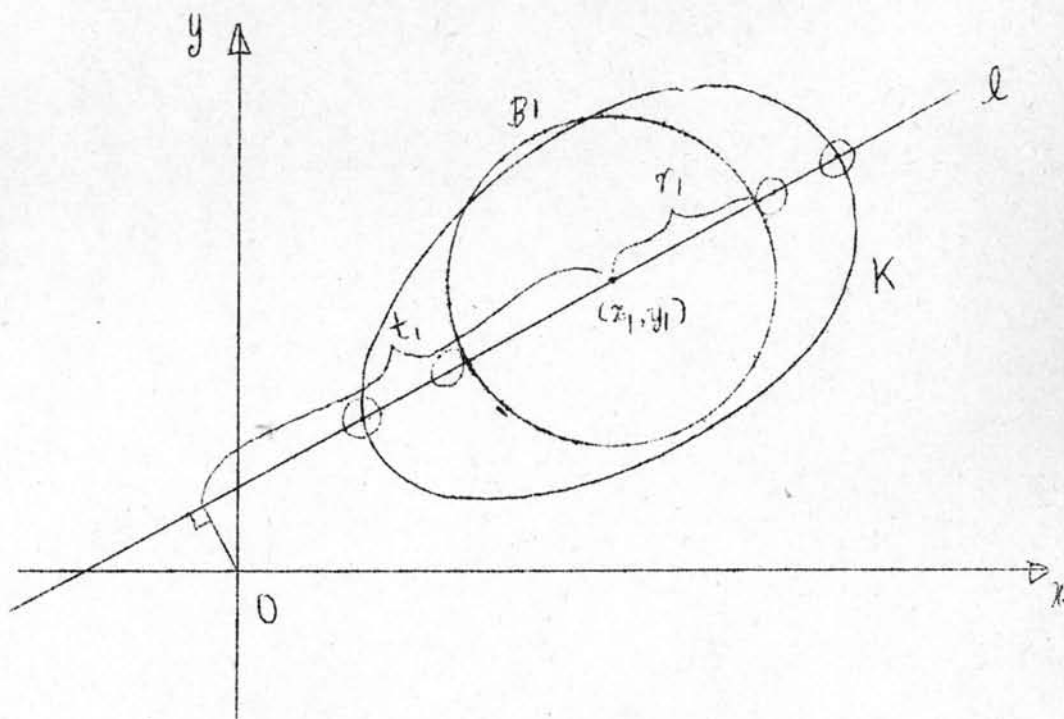

Figure 29

In this case, we have 2 subcases :

subcase 1 Let $X_{2_1} = \left\{ (B_1, B_2) \in X_2 \mid t_2 < t_1 \right\}$

In this subcase, we have

$$r = t_1 - t_2 - r_1 - r_2, \text{ if we}$$

fix	t_1, r_1, r_2, l	then	t_2	varies from	a	to	$t_1 - r_1 - r_2$
fix	t_1, r_1, l	then	r_2	varies from	0	to	$t_1 - a - r_1$
fix	r_1, l	then	t_1	varies from	$a + r_1$	to	$b - r_1$
fix	l	then	r_1	varies from	0	to	$\frac{d}{2}$

subcase 2 Let $X_{22} = \{(B_1, B_2) \in X_2 / t_1 < t_2\}$

In this subcase we have

$$r = t_2 - t_1 - r_1 - r_2, \text{ If we}$$

fix t_1, r_1, r_2, l then t_2 varies from $t_1 + r_1 + r_2$ to b

fix t_1, r_1, l then r_2 varies from 0 to $b - t_1 - r_1$

fix r_1, l then t_1 varies from $a + r_1$ to $b - r_1$

fix l then r_1 varies from 0 to $\frac{a}{2}$

We see that $X_2 = X_{21} \cup X_{22}$

$$\text{and } X_{21} \cap X_{22} = \emptyset$$

therefore

$$\int_{X_2} r dB_1 dB_2 = \int_{X_{21}} r dB_1 dB_2 + \int_{X_{22}} r dB_1 dB_2$$

case 3 Let $X_3 = \{(B_1, B_2) \in X / \text{exactly one of the}$

intersection points between B_1 and l is contained in K and the other has t coordinate $\geq b\}$

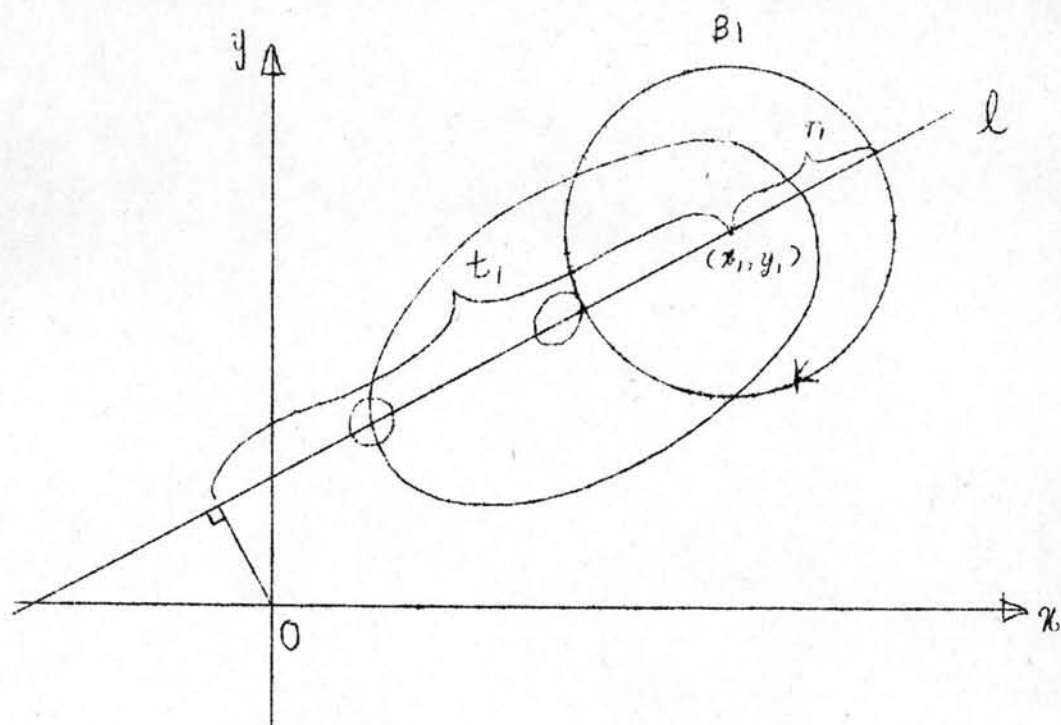

Figure 30

In this case we have

$$r = t_1 - t_2 - r_1 - r_2, \text{ if we}$$

fix t_1, r_1, r_2, l then t_2 varies from a to $t_1 - r_1 - r_2$

fix t_1, r_1, l then r_2 varies from 0 to $t_1 - a - r_1$

fix r_1, l then t_1 varies from $b - r_1$ to b

fix l then r_1 varies from 0 to \angle .

We see that $X = X_1 \cup X_2 \cup X_3$

$$\text{and } X_1 \cap X_2 \cap X_3 = \emptyset, \quad X_1 \cap X_2 = \emptyset$$

$$X_1 \cap X_3 = \emptyset, \quad X_2 \cap X_3 = \emptyset$$

therefore

$$(4.5) \quad \int_X r dB_1 dB_2 = \int_{X_1} r dB_1 dB_2 + \int_{X_2} r dB_1 dB_2 + \int_{X_3} r dB_1 dB_2$$

First of all, we will find $\int_{X_1} r dB_1 dB_2$

From (4.3) we have

$$\begin{aligned} \int_{X_1} r dB_1 dB_2 &= \int_{X_1} r |t_2 - t_1| dG dt_1 dt_2 dr_1 dr_2 \\ &= \int \left[\int_{t_1+r_1+r_2}^b (t_2 - t_1 - r_1 - r_2)(t_2 - t_1) dt_2 \right] dr_2 dt_1 dr_1 dG \\ &= \int \left[\int_{t_1+r_1+r_2}^b (t_2^2 - 2t_1 t_2 - t_2 r_1 - t_2 r_2 + t_1^2 + t_1 r_1 + t_1 r_2) dt_2 \right] dr_2 dt_1 dr_1 dG \\ &= \int \left[\frac{t_2^3}{3} - \frac{2t_1 t_2^2}{2} - \frac{t_2^2 r_1}{2} - \frac{t_2^2 r_2}{2} + t_1^2 t_2 + t_1 t_2 r_1 \right. \\ &\quad \left. + t_1 t_2 r_2 \right]_{t_1+r_1+r_2}^b dr_2 dt_1 dr_1 dG \\ &= \int \left[\frac{b^3}{3} - b^2 t_1 - \frac{b^2 r_1}{2} - \frac{b^2 r_2}{2} + b t_1^2 + b t_1 r_1 + b t_1 r_2 \right. \\ &\quad - \frac{(t_1+r_1+r_2)^3}{3} + t_1(t_1+r_1+r_2)^2 + \frac{r_1}{2}(t_1+r_1+r_2)^2 \\ &\quad + \frac{r_2}{2}(t_1+r_1+r_2)^2 - t_1^2(t_1+r_1+r_2) - t_1 r_1(t_1+r_1+r_2) \\ &\quad \left. - t_1 r_2(t_1+r_1+r_2) \right] dr_2 dt_1 dr_1 dG \end{aligned}$$

$$\begin{aligned}
&= \int \left[\frac{b^3}{3} - b^2 t_1 - \frac{b^2 r_1}{2} - \frac{b^2 r_2}{2} + b t_1^2 + b t_1 r_1 + b t_1 r_2 - \frac{t_1^3}{3} - t_1^2 r_1 \right. \\
&\quad - t_1 r_1^2 - \frac{r_1^3}{3} - t_1^2 r_2 - 2 t_1 r_1 r_2 - r_1^2 r_2 - t_1 r_2^2 - r_1 r_2^2 - \frac{r_2^3}{3} + t_1^3 \\
&\quad + t_1 r_1^2 + t_1 r_2^2 + 2 t_1^2 r_1 + 2 t_1^2 r_2 + 2 t_1 r_1 r_2 + \frac{t_1^2 r_1}{2} + \frac{r_1^3}{2} \\
&\quad + \frac{r_1 r_2^2}{2} + t_1 r_1^2 + t_1 r_1 r_2 + r_1^2 r_2 + \frac{t_1^2 r_2}{2} + \frac{r_1 r_2}{2} + \frac{r_2^3}{2} \\
&\quad + t_1 r_1 r_2 + t_1 r_2^2 + r_1 r_2^2 - t_1^3 - t_1^2 r_1 - t_1^2 r_2 - t_1 r_1^2 - t_1 r_2^2 \\
&\quad \left. - t_1 r_1 r_2 - t_1 r_2^2 - t_1 r_1 r_2 - t_1 r_2^2 \right] dr_2 dt_1 dr_1 dG \\
&= \int \left[\int_0^{b-t_1-r_1} \left(\frac{b^3}{3} - b^2 t_1 - \frac{b^2 r_1}{2} - \frac{b^2 r_2}{2} + b t_1^2 + b t_1 r_1 + b t_1 r_2 - \frac{t_1^3}{3} + \frac{r_1^3}{6} \right. \right. \\
&\quad \left. \left. + \frac{r_1 r_2^2}{2} + \frac{r_2^3}{6} - \frac{t_1^2 r_1}{2} + \frac{r_1 r_2^2}{2} - \frac{t_1^2 r_2}{2} \right) dr_2 \right] dt_1 dr_1 dG \\
&= \int \left[\frac{b^3}{3} r_2 - b^2 t_1 r_2 - \frac{b^2 r_1 r_2}{2} - \frac{b^2 r_2^2}{4} + b t_1^2 r_2 + b t_1 r_1 r_2 + \frac{b t_1 r_2^2}{2} \right. \\
&\quad - \frac{t_1^3 r_2}{3} + \frac{r_1^3 r_2}{6} + \frac{r_1 r_2^2}{4} + \frac{r_2^4}{24} - \frac{t_1^2 r_1 r_2}{2} + \frac{r_1 r_2^3}{6} \\
&\quad \left. - \frac{t_1^2 r_2^2}{4} \right]_0^{b-t_1-r_1} dt_1 dr_1 dG
\end{aligned}$$

$$\begin{aligned}
&= \int \left[\frac{b^3}{3}(b-t_1-r_1) - b^2 t_1 (b-t_1-r_1) - \frac{b r_1^2}{2} (b-t_1-r_1) - \frac{b^2}{4} (b-t_1-r_1)^2 \right. \\
&\quad + b t_1^2 (b-t_1-r_1) + b t_1 r_1 (b-t_1-r_1) + \frac{b t_1}{2} (b-t_1-r_1)^2 - \frac{t_1^3}{3} (b-t_1-r_1) \\
&\quad + \frac{r_1^3}{6} (b-t_1-r_1) + \frac{r_1^2}{4} (b-t_1-r_1)^2 + \frac{(b-t_1-r_1)^4}{24} - \frac{t_1^2 r_1}{2} (b-t_1-r_1) \\
&\quad \left. + \frac{r_1}{6} (b-t_1-r_1)^3 - \frac{t_1^2}{4} (b-t_1-r_1)^2 \right] dt_1 dr_1 dG
\end{aligned}$$

$$\begin{aligned}
&= \int \left[\frac{b^4}{3} - \frac{b^3 t_1}{3} - \frac{b^3 r_1}{3} + b^2 t_1^2 + b^2 t_1 r_1 - \frac{b^3 r_1}{2} + \frac{b^2 t_1 r_1}{2} + \frac{b^2 r_1^2}{2} \right. \\
&\quad - \frac{b^4}{4} - \frac{b^2 t_1^2}{4} - \frac{b^2 r_1^2}{4} + \frac{b^3 t_1}{2} + \frac{b^3 r_1}{2} - \frac{b^2 t_1 r_1}{2} + b^2 t_1^2 - b t_1^3 \\
&\quad - b t_1^2 r_1 + b^2 t_1 r_1 - b t_1^2 r_1 - b t_1 r_1^2 + \frac{b^3 t_1}{2} + \frac{b t_1^3}{2} \\
&\quad + \frac{b t_1 r_1^2}{2} - b^2 t_1^2 - b^2 t_1 r_1 + b t_1^2 r_1 - \frac{b t_1^3}{3} + \frac{t_1^4}{3} + \frac{t_1^3 r_1}{3} \\
&\quad + \frac{b r_1^3}{6} - \frac{t_1 r_1^3}{6} - \frac{r_1^4}{6} + \frac{b^2 r_1^2}{4} + \frac{t_1^2 r_1^2}{4} + \frac{r_1^4}{4} - \frac{b t_1 r_1^2}{2} \\
&\quad - \frac{b r_1^3}{2} + \frac{t_1 r_1^3}{2} + \frac{b^4}{24} - \frac{b^3 t_1}{6} + \frac{b^2 t_1^2}{4} - \frac{b t_1^3}{6} + \frac{t_1^4}{24} - \frac{b^3 r_1}{6} \\
&\quad + \frac{b^2 t_1 r_1}{2} - \frac{b t_1^2 r_1}{2} + \frac{t_1^3 r_1}{6} + \frac{b^2 r_1^2}{4} - \frac{b t_1 r_1^2}{2} + \frac{t_1^2 r_1^2}{4} - \frac{b r_1^3}{6} \\
&\quad + \frac{t_1 r_1^3}{6} + \frac{r_1^4}{24} - \frac{b t_1^2 r_1}{2} + \frac{t_1^3 r_1}{2} + \frac{t_1^2 r_1^2}{2} + \frac{b^3 r_1}{6} - \frac{b^2 t_1 r_1}{2} \\
&\quad + \frac{b t_1^2 r_1}{2} - \frac{t_1^3 r_1}{6} - \frac{b^2 r_1^2}{2} + b t_1 r_1^2 - \frac{t_1^2 r_1^2}{2} + \frac{b r_1^3}{2} - \frac{t_1 r_1^3}{2} - \frac{r_1^4}{6} \\
&\quad \left. - \frac{b^2 t_1^2}{4} - \frac{t_1^4}{4} - \frac{t_1^2 r_1^2}{4} + \frac{b t_1^3}{2} + \frac{b t_1^2 r_1}{2} - \frac{t_1^3 r_1}{2} \right] dt_1 dr_1 dG
\end{aligned}$$

$$= \int \left[\int_a^{a+r_1} \left(\frac{b^4}{8} - \frac{b^3 t_1}{2} - \frac{b^3 r_1}{3} - \frac{3b^2 t_1^2}{4} + b^2 t_1 r_1 + \frac{b^2 r_1^2}{4} - \frac{b t_1^3}{2} \right. \right. \\ \left. \left. - b t_1^2 r_1 - \frac{b t_1 r_1^2}{2} + \frac{t_1^4}{8} + \frac{t_1^3 r_1}{3} - \frac{r_1^4}{24} + \frac{t_1^2 r_1^2}{4} \right) dt_1 \right] dr_1 dG$$

$$= \int \left[\frac{b^4}{8} t_1 - \frac{b^3 t_1^2}{4} - \frac{b^3 r_1 t_1}{3} + \frac{3b^2 t_1^3}{12} + \frac{b^2 t_1^2 r_1}{2} + \frac{b^2 r_1^2 t_1}{4} \right. \\ \left. - \frac{b t_1^4}{8} - \frac{b t_1^3 r_1}{4} - \frac{b t_1^2 r_1^2}{4} + \frac{t_1^5}{40} + \frac{t_1^4 r_1}{12} - \frac{r_1^4 t_1}{24} \right. \\ \left. + \frac{t_1^3 r_1^2}{12} \int_a^{a+r_1} \right] dr_1 dG$$

$$= \int \left[\frac{b^4}{8} (a+r_1) - \frac{b^3}{4} (a+r_1)^2 - \frac{b^3 r_1}{3} (a+r_1) + \frac{b^2}{4} (a+r_1)^3 + \frac{b^2 r_1}{2} (a+r_1)^2 \right. \\ \left. + \frac{b^2 r_1^2}{4} (a+r_1) - \frac{b}{8} (a+r_1)^4 - \frac{b r_1}{3} (a+r_1)^3 - \frac{b r_1^2}{4} (a+r_1)^2 + \frac{(a+r_1)^5}{40} \right. \\ \left. + \frac{r_1}{12} (a+r_1)^4 - \frac{r_1^4}{24} (a+r_1) + \frac{r_1^2}{12} (a+r_1)^3 - \frac{a b^4}{8} + \frac{a^2 b^3}{4} + \frac{a b^3 r_1}{3} - \frac{a^3 b^2}{4} \right. \\ \left. - \frac{a^2 b^2 r_1}{2} - \frac{a b^2 r_1^2}{4} + \frac{a^4 b}{8} + \frac{a^3 b r_1}{3} + \frac{a^2 b r_1^2}{4} - \frac{a^5}{40} - \frac{a^4 r_1}{12} \right. \\ \left. + \frac{a r_1^4}{24} - \frac{a^3 r_1^2}{12} \right] dr_1 dG$$

$$\begin{aligned}
&= \int \left[\frac{ab^4}{8} + \frac{b^4 r_1}{8} - \frac{a^2 b^3}{4} - \frac{ab^3 r_1}{2} - \frac{b^3 r_1^2}{4} - \frac{ab^3 r_1}{3} - \frac{b^3 r_1^2}{3} \right. \\
&\quad + \frac{a^3 b^2}{4} + \frac{3a^2 b^2 r_1}{4} + \frac{3ab^2 r_1^2}{4} + \frac{b^2 r_1^3}{4} + \frac{a^2 b^2 r_1}{2} + ab^2 r_1^2 \\
&\quad + \frac{b^2 r_1^3}{2} + \frac{ab^2 r_1^2}{4} + \frac{b^2 r_1^3}{4} - \frac{a^4 b}{8} - \frac{a^3 b}{2} - \frac{3a^2 b r_1^2}{4} - \frac{ab r_1^3}{2} \\
&\quad - \frac{b r_1^4}{8} - \frac{a^3 b r_1}{3} - a^2 b r_1^2 - ab r_1^3 - \frac{b r_1^4}{3} - \frac{a^2 b r_1^2}{4} - \frac{ab r_1^3}{2} \\
&\quad - \frac{b r_1^4}{4} + \frac{a^5}{40} + \frac{a^4 r_1}{8} + \frac{a^3 r_1^2}{4} + \frac{a^2 r_1^3}{4} + \frac{a r_1^4}{8} + \frac{r_1^5}{40} + \frac{a^4 r_1}{12} \\
&\quad + \frac{a^3 r_1^2}{3} + \frac{a^2 r_1^3}{2} + \frac{a r_1^4}{3} + \frac{r_1^5}{12} - \frac{a r_1^4}{24} - \frac{r_1^5}{24} + \frac{a^3 r_1^2}{12} + \frac{a^2 r_1^3}{4} \\
&\quad + \frac{a r_1^4}{4} + \frac{r_1^5}{12} - \frac{ab^4}{8} + \frac{a^2 b^3}{4} + \frac{ab^3 r_1}{3} - \frac{a^3 b^2}{4} - \frac{a^2 b^2 r_1}{2} - \frac{ab^2 r_1^2}{4} \\
&\quad + \frac{a^4 b}{8} + \frac{a^3 b r_1}{3} + \frac{a^2 b r_1^2}{4} - \frac{a^5}{40} - \frac{a^4 r_1}{12} + \frac{a r_1^4}{24} - \frac{a^3 r_1^2}{12} \left. \right] dr_1 dG \\
&= \int \left[\frac{b^4 r_1}{8} - \frac{ab^3 r_1}{2} - \frac{7}{12} b^3 r_1^2 + \frac{3}{4} a^2 b^2 r_1 + \frac{7}{4} ab^2 r_1^2 + b^2 r_1^3 \right. \\
&\quad - \frac{a^3 b r_1}{2} - \frac{7}{4} a^2 b r_1^2 - 2ab r_1^3 - \frac{17}{24} b r_1^4 + \frac{a^4 r_1}{8} + \frac{7}{12} a^3 r_1^2 \\
&\quad \left. + a^2 r_1^3 + \frac{17}{24} a r_1^4 + \frac{3r_1^5}{20} \right] dr_1 dG.
\end{aligned}$$

$$\begin{aligned}
&= \int \left[r_1 \left(\frac{b^4}{8} - \frac{b^3 a}{2} + \frac{3b^2 a^2}{4} - \frac{ba^3}{2} + \frac{a^4}{8} \right) + r_1^2 \left(-\frac{7}{12} b^3 + \frac{7b^2 a}{4} \right. \right. \\
&\quad \left. \left. - \frac{7ba^2}{4} + \frac{7a^3}{12} \right) + r_1^3 (b^2 - 2ab + a^2) + r_1^4 \left(-\frac{17b}{24} + \frac{17a}{24} \right) \right. \\
&\quad \left. + \frac{3r_1^5}{20} \right] dr_1 dG \\
&= \int \left[\int_0^{\Delta} \left(\frac{\Delta^4 r_1}{8} - \frac{7}{12} \Delta^3 r_1^2 + \Delta^2 r_1^3 - \frac{17}{24} \Delta r_1^4 + \frac{3r_1^5}{20} \right) dr_1 \right] dG \\
&= \int \left[\frac{\Delta^4 r_1^2}{16} - \frac{7}{12} \frac{\Delta^3 r_1^3}{3} + \frac{\Delta^2 r_1^4}{4} - \frac{17}{24} \frac{\Delta r_1^5}{5} + \frac{3r_1^6}{120} \right]_0^{\Delta} dG \\
&= \int \left(\frac{\Delta^6}{16} - \frac{7\Delta^6}{36} + \frac{\Delta^6}{4} - \frac{17\Delta^6}{120} + \frac{\Delta^6}{40} \right) dG \\
&= \frac{1}{720} \int \Delta^6 dG.
\end{aligned}$$

$L \cap K \neq \emptyset$

next, we will find

$$\begin{aligned}
\int_{X_3} r dB_1 dB_2 &= \int \left[\int_a^{t_1 - r_1 - r_2} (t_1 - t_2 - r_1 - r_2)(t_1 - t_2) dt_2 \right] dr_2 dt_1 dr_1 dG, \\
&= \int \left[\int_a^{t_1 - r_1 - r_2} (t_1^2 - 2t_1 t_2 - t_1 r_1 - t_1 r_2 + t_2^2 + t_2 r_1 + t_2 r_2) dt_2 \right] \\
&\quad dr_2 dt_1 dr_1 dG \\
&= \int \left[t_1^2 t_2 - \frac{2t_1 t_2^2}{2} - t_1 t_2 r_1 - t_1 t_2 r_2 + \frac{t_2^3}{3} + \frac{t_2 r_1}{2} \right. \\
&\quad \left. + \frac{t_2 r_2}{2} \right]_a^{t_1 - r_1 - r_2} dr_2 dt_1 dr_1 dG
\end{aligned}$$

$$\begin{aligned}
&= \int \int \left[t_1^2(t_1 - r_1 - r_2) - t_1(t_1 - r_1 - r_2)^2 - t_1 r_1(t_1 - r_1 - r_2) \right. \\
&\quad - t_1 r_2(t_1 - r_1 - r_2) + \frac{(t_1 - r_1 - r_2)^3}{3} + \frac{r_1}{2}(t_1 - r_1 - r_2)^2 + \frac{r_2}{2}(t_1 - r_1 - r_2)^2 \\
&\quad \left. - at_1^2 + a^2 t_1 + at_1 r_1 + at_1 r_2 - \frac{a^3}{3} - \frac{a^2 r_1}{2} - \frac{a^2 r_2}{2} \right] dr_2 dt_1 dr_1 dG
\end{aligned}$$

$$\begin{aligned}
&= \int \int \left[t_1^3 - t_1^2 r_1 - t_1^2 r_2 - t_1^3 - t_1 r_1^2 - t_1 r_2^2 + 2t_1^2 r_1 + 2t_1^2 r_2 - 2t_1 r_1 r_2 \right. \\
&\quad - t_1^2 r_1 + t_1 r_1^2 + t_1 r_1 r_2 - t_1^2 r_2 + t_1 r_1 r_2 + t_1 r_2^2 + \frac{t_1^3}{3} - t_1^2 r_1 \\
&\quad + t_1 r_1^2 - \frac{r_1^3}{3} - t_1^2 r_2 + 2t_1 r_1 r_2 - r_1^2 r_2 + t_1 r_2^2 - r_1 r_2^2 - \frac{r_2^3}{3} \\
&\quad + \frac{t_1^2 r_1}{2} + \frac{r_1^3}{2} + \frac{r_1 r_2^2}{2} - t_1 r_1^2 - t_1 r_1 r_2 + r_1^2 r_2 + \frac{t_1 r_2^2}{2} + \frac{r_1 r_2^2}{2} \\
&\quad + \frac{r_2^3}{2} - t_1 r_1 r_2 - t_1 r_2^2 + r_1 r_2^2 - at_1^2 + a^2 t_1 + at_1 r_1 \\
&\quad \left. + at_1 r_2 - \frac{a^3}{3} - \frac{a^2 r_1}{2} - \frac{a^2 r_2}{2} \right] dr_2 dt_1 dr_1 dG
\end{aligned}$$

$$\begin{aligned}
&= \int \int \left[\int_0^{t_1 - a - r_1} \left(\frac{t_1^3}{3} - \frac{t_1^2 r_1}{2} - \frac{t_1^2 r_2}{2} + \frac{r_1^3}{6} + \frac{r_1^2 r_2}{2} + \frac{r_1 r_2^2}{2} + \frac{r_2^3}{6} - at_1^2 \right. \right. \\
&\quad \left. \left. + a^2 t_1 + at_1 r_1 + at_1 r_2 - \frac{a^3}{3} - \frac{a^2 r_1}{2} - \frac{a^2 r_2}{2} \right) dr_2 \right] dt_1 dr_1 dG
\end{aligned}$$

$$\begin{aligned}
&= \int \int \left[\frac{t_1^3 r_2}{3} - \frac{t_1^2 r_1 r_2}{2} - \frac{t_1^2 r_2^2}{4} + \frac{r_1^3 r_2}{6} + \frac{r_1^2 r_2^2}{4} + \frac{r_1 r_2^3}{6} + \frac{r_2^4}{24} \right. \\
&\quad - at_1^2 r_2 + a^2 t_1 r_2 + at_1 r_1 r_2 + \frac{at_1 r_2^2}{2} - \frac{a^3 r_2}{3} - \frac{a^2 r_1 r_2}{2} \\
&\quad \left. - \frac{a^2 r_2^2}{4} \int_0^{t_1 - a - r_1} \right] dt_1 dr_1 dG
\end{aligned}$$

$$\begin{aligned}
&= \int \left[\frac{t_1^3}{3}(t_1-a-r_1) - \frac{t_1^2 r_1}{2}(t_1-a-r_1) - \frac{t_1^2}{4}(t_1-a-r_1)^2 + \frac{r_1^3}{6}(t_1-a-r_1) \right. \\
&\quad + \frac{r_1^2}{4}(t_1-a-r_1)^2 + \frac{r_1}{6}(t_1-a-r_1)^3 + \frac{(t_1-a-r_1)^4}{24} - at_1^2(t_1-a-r_1) \\
&\quad + a^2 t_1(t_1-a-r_1) + at_1 r_1(t_1-a-r_1) + \frac{at_1}{2}(t_1-a-r_1)^2 - \frac{a^3}{3}(t_1-a-r_1) \\
&\quad \left. - \frac{a^2 r_1}{2}(t_1-a-r_1) - \frac{a^2}{4}(t_1-a-r_1)^2 \right] dt_1 dr_1 dG \\
&= \int \left[\frac{t_1^4}{3} - \frac{at_1^3}{3} - \frac{t_1^3 r_1}{3} - \frac{t_1^3 r_1}{2} + \frac{at_1^2 r_1}{2} + \frac{t_1^2 r_1^2}{2} - \frac{t_1^4}{4} \right. \\
&\quad - \frac{a^2 t_1^2}{4} - \frac{t_1^2 r_1^2}{4} + \frac{at_1^3}{2} + \frac{t_1^3 r_1}{2} - \frac{at_1^2 r_1}{2} + \frac{t_1 r_1^3}{6} - \frac{ar_1^3}{6} - \frac{r_1^4}{6} \\
&\quad + \frac{t_1^2 r_1^2}{4} + \frac{a^2 r_1^2}{4} + \frac{r_1^4}{4} - \frac{at_1 r_1^2}{2} - \frac{t_1 r_1^3}{2} + \frac{ar_1^3}{2} + \frac{t_1^3 r_1}{6} \\
&\quad - \frac{at_1^2 r_1}{2} + \frac{a^2 t_1 r_1}{2} - \frac{a^3 r_1}{6} - \frac{t_1^2 r_1^2}{2} + at_1 r_1^2 - \frac{a^2 r_1^2}{2} \\
&\quad + \frac{t_1 r_1^3}{2} - \frac{ar_1^3}{2} - \frac{r_1^4}{6} + \frac{t_1^4}{24} - \frac{t_1^3}{6} + \frac{at_1^2}{6} + \frac{a^3 t_1}{6} + \frac{a^4}{24} - \frac{t_1^3 r_1}{6} \\
&\quad + \frac{at_1^2 r_1}{2} - \frac{a^2 t_1 r_1}{2} + \frac{a^3 r_1}{6} + \frac{t_1^2 r_1^2}{4} - \frac{at_1 r_1^2}{2} + \frac{a^2 r_1^2}{4} \\
&\quad - \frac{t_1 r_1^3}{6} + \frac{ar_1^3}{6} + \frac{r_1^4}{24} - at_1^3 + a^2 t_1^2 + at_1^2 r_1 + a^2 t_1^2 \\
&\quad - a^3 t_1 - a^2 t_1 r_1 + at_1^2 r_1 - a^2 t_1 r_1 - at_1 r_1^2 + \frac{at_1^3}{2} + \frac{a^3 t_1}{2} \\
&\quad + \frac{at_1 r_1^2}{2} - a^2 t_1^2 - at_1^2 r_1 + a^2 t_1 r_1 - \frac{a^3 t_1}{3} + \frac{a^4}{3} + \frac{a^3 r_1}{3} \\
&\quad - \frac{a^2 t_1 r_1}{2} + \frac{a^3 r_1}{2} + \frac{a^2 r_1^2}{2} - \frac{a^2 t_1^2}{4} - \frac{a^4}{4} - \frac{a^2 r_1^2}{4} + \frac{a^3 t_1}{2} \\
&\quad \left. + \frac{a^2 t_1 r_1}{2} - \frac{a^3 r_1}{2} \right] dt_1 dr_1 dG
\end{aligned}$$

$$\begin{aligned}
 &= \int \left[\int_{b-r_1}^b \left(\frac{t_1^4}{8} - \frac{at_1^3}{2} - \frac{t_1^3 r_1}{3} + at_1^2 r_1 + \frac{t_1^2 r_1^2}{4} + \frac{3}{4} a^2 t_1^2 - \frac{r_1^4}{24} \right. \right. \\
 &\quad \left. \left. + \frac{a^2 r_1^2}{4} - \frac{at_1 r_1^2}{2} - a^2 t_1 r_1 + \frac{a^3 r_1}{3} - \frac{a^3 t_1}{2} + \frac{a^4}{8} \right) dt_1 \right] dr_1 dG \\
 &= \int \left[\frac{t_1^5}{40} - \frac{at_1^4}{8} - \frac{t_1^4 r_1}{12} + \frac{at_1^3 r_1}{3} + \frac{t_1^3 r_1^2}{12} + \frac{3}{4} \frac{a^2 t_1^3}{3} - \frac{r_1^4 t_1}{24} \right. \\
 &\quad \left. + \frac{a^2 r_1^2 t_1}{4} - \frac{at_1^2 r_1^2}{4} - \frac{a^2 t_1^2 r_1}{2} + \frac{a^3 r_1 t_1}{3} - \frac{a^3 t_1^2}{4} + \frac{a^4 t_1}{8} \right]_{b-r_1}^b dr_1 dG \\
 &= \int \left[\frac{b^5}{40} - \frac{ab^4}{8} - \frac{b^4 r_1}{12} + \frac{ab^3 r_1}{3} + \frac{b^3 r_1^2}{12} + \frac{a^2 b^3}{4} - \frac{br_1^4}{24} + \frac{a^2 br_1^2}{4} \right. \\
 &\quad \left. - \frac{ab^2 r_1^2}{4} - \frac{a^2 b^2 r_1}{2} + \frac{a^3 br_1}{3} - \frac{a^3 b^2}{4} + \frac{a^4 b}{8} - \frac{(b-r_1)^5}{40} \right. \\
 &\quad \left. + \frac{a(b-r_1)^4}{8} + \frac{r_1(b-r_1)^4}{12} - \frac{ar_1(b-r_1)^3}{3} - \frac{r_1^2(b-r_1)^3}{12} - \frac{a^2(b-r_1)^3}{4} \right. \\
 &\quad \left. + \frac{r_1^4}{24}(b-r_1) - \frac{a^2 r_1^2}{4}(b-r_1) + \frac{ar_1^2}{4}(b-r_1)^2 + \frac{a^2 r_1}{2}(b-r_1)^2 - \frac{a^3 r_1}{3}(b-r_1) \right. \\
 &\quad \left. + \frac{a^3}{4}(b-r_1)^2 - \frac{a^4}{8}(b-r_1) \right] dr_1 dG
 \end{aligned}$$

$$\begin{aligned}
= & \int \left[\frac{b^5}{40} - \frac{ab^4}{8} - \frac{b^4 r_1}{12} + \frac{ab^3 r_1}{3} + \frac{b^3 r_1^2}{12} + \frac{a^2 b^3}{4} - \frac{br_1^4}{24} + \frac{a^2 br_1^2}{4} \right. \\
& + \frac{ab^2 r_1^2}{4} - \frac{a^2 b^2 r_1}{2} + \frac{a^3 br_1}{3} - \frac{a^3 b^2}{4} + \frac{a^4 b}{8} - \frac{b^5}{40} + \frac{b^4 r_1}{8} \\
& - \frac{b^3 r_1^2}{4} + \frac{b^2 r_1^3}{4} - \frac{br_1^4}{8} + \frac{r_1^5}{40} + \frac{ab^4}{8} - \frac{ab^3 r_1}{2} + \frac{3ab^2 r_1^2}{4} - \frac{abr_1^3}{2} \\
& + \frac{ar_1^4}{8} + \frac{b^4 r_1}{12} - \frac{b^3 r_1^2}{3} + \frac{b^2 r_1^3}{2} - \frac{br_1^4}{3} + \frac{r_1^5}{12} - \frac{ab^3 r_1}{3} \\
& + ab^2 r_1^2 - abr_1^3 + \frac{ar_1^4}{3} - \frac{b^3 r_1^2}{12} + \frac{b^2 r_1^3}{4} - \frac{br_1^4}{4} + \frac{r_1^5}{12} - \frac{a^2 b^3}{4} \\
& + \frac{3a^2 b^2 r_1}{4} - \frac{3}{4} a^2 br_1^2 + \frac{a^2 r_1^3}{4} + \frac{br_1^4}{24} - \frac{r_1^5}{24} - \frac{a^2 br_1^2}{4} + \frac{a^2 r_1^3}{4} \\
& + \frac{ab^2 r_1^2}{4} - \frac{abr_1^3}{2} + \frac{ar_1^4}{4} + \frac{a^2 b^2 r_1}{2} - a^2 br_1^2 + \frac{a^2 r_1^3}{2} - \frac{a^3 br_1}{3} \\
& \left. + \frac{a^3 r_1^2}{3} + \frac{a^3 b^2}{4} - \frac{a^3 br_1}{2} + \frac{a^3 r_1^2}{4} - \frac{a^4 b}{8} + \frac{a^4 r_1}{8} \right] dr_1 dG
\end{aligned}$$

$$\begin{aligned}
= & \int \left[\frac{b^4 r_1}{8} - \frac{ab^3 r_1}{2} - \frac{7}{12} b^3 r_1^2 - \frac{17}{24} br_1^4 - \frac{7}{4} a^2 br_1^2 + \frac{7}{4} ab^2 r_1^2 \right. \\
& + \frac{3}{4} a^2 b^2 r_1 - \frac{a^3 br_1}{2} + b^2 r_1^3 + \frac{3}{20} r_1^5 - 2abr_1^3 + \frac{17}{24} ar_1^4 + a^2 r_1^3 \\
& \left. + \frac{7}{12} a^3 r_1^2 + \frac{a^4 r_1}{8} \right] dr_1 dG
\end{aligned}$$

$$\begin{aligned}
 & \int \left[r_1 \left(\frac{b^4}{8} - \frac{b^3 a}{2} + \frac{3}{4} b^2 a^2 - \frac{b a^3}{2} + \frac{a^4}{8} \right) + r_1^2 \left(-\frac{7}{12} b^3 + \frac{7}{4} b a^2 - \frac{7}{4} b a^2 + \frac{7}{12} a^3 \right) + r_1^3 (b^2 - 2ab + a^2) + r_1^4 \left(-\frac{17}{24} b + \frac{17}{24} a \right) + \frac{3}{20} r_1^5 \right] dr_1 dG \\
 &= \int \left[\int_0^4 \left(\frac{\Delta^4 r_1}{8} - \frac{7}{12} \Delta^3 r_1^2 + \Delta^2 r_1^3 - \frac{17}{24} \Delta r_1^4 + \frac{3}{20} r_1^5 \right) dr_1 \right] dG \\
 &= \int \left[\frac{\Delta^4 r_1^2}{16} - \frac{7}{12} \frac{\Delta^3 r_1^3}{3} + \frac{\Delta^2 r_1^4}{4} - \frac{17}{24} \frac{\Delta r_1^5}{5} + \frac{3}{20} \frac{r_1^6}{6} \right]_0^4 dG \\
 &= \int \left(\frac{\Delta^6}{16} - \frac{7 \Delta^6}{36} + \frac{\Delta^6}{4} - \frac{17 \Delta^6}{120} + \frac{\Delta^6}{40} \right) dG \\
 &= \frac{1}{720} \int \Delta^6 dG \\
 & \quad \text{LNK} \neq \phi
 \end{aligned}$$

At last, we will find

$$\begin{aligned}
 \int_{X_2} r dB_1 dB_2 &= \int \left[\int_a^{t_1 - r_1 - r_2} (t_1 - t_2 - r_1 - r_2)(t_1 - t_2) dt_2 + \int_{t_1 + r_1 + r_2}^b (t_2 - t_1 - r_1 - r_2)(t_2 - t_1) dt_2 \right] dr_2 dt_1 dr_1 dG \\
 &= \int \left[\int_0^{t_1 - a - r_1} \left(\frac{t_1^3}{3} - \frac{t_1^2 r_1}{2} - \frac{t_1 r_2^2}{2} + \frac{r_1^3}{6} + \frac{r_1^2 r_2}{2} + \frac{r_1 r_2^2}{2} + \frac{r_2^3}{6} - a t_1^2 + a^2 t_1 + a t_1 r_1 + a t_1 r_2 - \frac{a^3}{3} - \frac{a^2 r_1}{2} - \frac{a^2 r_2}{2} \right) dr_2 \right. \\
 & \quad + \int_0^{b - t_1 - r_1} \left(\frac{b^3}{3} - b^2 t_1 - \frac{b^2 r_1}{2} - \frac{b^2 r_2}{2} + b t_1^2 + b t_1 r_1 + b t_1 r_2 - \frac{t_1^3}{3} + \frac{r_1^3}{6} + \frac{r_1^2 r_2}{2} + \frac{r_2^3}{6} - \frac{t_1^2 r_1}{2} + \frac{r_1 r_2^2}{2} - \frac{t_1 r_2^2}{2} \right) dr_2 \left. \right] dt_1 dr_1 dG
 \end{aligned}$$

$$\begin{aligned}
&= \int \int_{a+r_1}^{b-r_1} \left(\frac{t_1^4}{3} - \frac{at_1^3}{2} - \frac{t_1^3 r_1}{3} + at_1^2 r_1 + \frac{t_1^2 r_1^2}{4} + \frac{3}{4} a^2 t_1^2 - \frac{r_1^4}{24} + \frac{a^2 r_1^2}{4} \right. \\
&\quad - \frac{at_1 r_1^2}{2} - a^2 t_1 r_1 + \frac{a^3 r_1}{3} - \frac{a^3 t_1}{2} + \frac{a^4}{8} + \frac{b^4}{8} - \frac{b^3 t_1}{2} - \frac{b^3 r_1}{3} \\
&\quad + \frac{3b^2 t_1^2}{4} + b^2 t_1 r_1 + \frac{b^2 r_1^2}{4} - \frac{bt_1^3}{2} - bt_1^2 r_1 - \frac{bt_1 r_1^2}{2} + \frac{t_1^4}{8} \\
&\quad \left. + \frac{t_1^3 r_1}{3} - \frac{r_1^4}{24} + \frac{t_1^2 r_1^2}{4} \right) dt_1 \Big] dr_1 dG
\end{aligned}$$

$$\begin{aligned}
&= \int \left[\frac{t_1^5}{20} - \frac{at_1^4}{8} + \frac{at_1^3 r_1}{3} + \frac{t_1^3 r_1^2}{6} + \frac{3a^2 t_1^3}{12} - \frac{r_1^4 t_1}{12} + \frac{a^2 r_1^2 t_1}{4} \right. \\
&\quad - \frac{at_1^2 r_1^2}{4} - \frac{a^2 t_1^2 r_1}{2} + \frac{a^3 r_1 t_1}{3} - \frac{a^3 t_1^2}{4} + \frac{a^4 t_1}{8} + \frac{b^4 t_1}{8} - \frac{b^3 t_1^2}{4} \\
&\quad - \frac{b^3 r_1 t_1}{3} + \frac{3b^2 t_1^3}{12} + \frac{b^2 t_1^2 r_1}{2} + \frac{b^2 r_1^2 t_1}{4} - \frac{bt_1^4}{8} - \frac{bt_1^3 r_1}{3} \\
&\quad \left. - \frac{bt_1^2 r_1^2}{4} \right]_{a+r_1}^{b-r_1} dr_1 dG .
\end{aligned}$$

$$\begin{aligned}
&= \int \left[\frac{(b-r_1)^5}{20} - \frac{a(b-r_1)^4}{8} + \frac{ar_1(b-r_1)^3}{3} + \frac{r_1^2(b-r_1)^3}{6} + \frac{a^2(b-r_1)^3}{4} - \frac{ar_1^2(b-r_1)^2}{2} \right. \\
&\quad - \frac{r_1^4(b-r_1)}{12} + \frac{a^2r_1^2(b-r_1)}{4} - \frac{ar_1^2(b-r_1)^2}{4} + \frac{a^3r_1(b-r_1)}{3} - \frac{a^3(b-r_1)^2}{4} \\
&\quad + \frac{a^4(b-r_1)}{8} + \frac{b^4(b-r_1)}{8} - \frac{b^3(b-r_1)^2}{4} - \frac{b^3r_1(b-r_1)}{3} + \frac{b^2(b-r_1)^3}{4} \\
&\quad + \frac{b^2r_1(b-r_1)^2}{2} + \frac{b^2r_1^2(b-r_1)}{4} - \frac{b(b-r_1)^4}{8} - \frac{br_1(b-r_1)^3}{3} - \frac{br_1^2(b-r_1)^2}{4} \\
&\quad - \frac{(a+r_1)^5}{20} + \frac{a(a+r_1)^4}{8} - \frac{ar_1(a+r_1)^3}{3} - \frac{r_1^2(a+r_1)^3}{6} - \frac{a^2(a+r_1)^3}{4} + \frac{r_1^4(a+r_1)}{12} \\
&\quad - \frac{a^2r_1^2(a+r_1)}{4} + \frac{ar_1^2(a+r_1)^2}{4} + \frac{a^2r_1(a+r_1)^2}{2} - \frac{a^3r_1(a+r_1)}{3} + \frac{a^3(a+r_1)^2}{4} \\
&\quad - \frac{a^4(a+r_1)}{8} - \frac{b^4(a+r_1)}{8} + \frac{b^3(a+r_1)^2}{4} + \frac{b^3r_1(a+r_1)}{3} - \frac{b^2(a+r_1)^3}{4} \\
&\quad - \frac{b^2r_1(a+r_1)^2}{2} - \frac{b^2r_1^2(a+r_1)}{4} + \frac{b(a+r_1)^4}{8} + \frac{br_1(a+r_1)^3}{3} \\
&\quad \left. + \frac{br_1^2(a+r_1)^2}{4} \right] dr_1 dG
\end{aligned}$$

$$\begin{aligned}
&= \int \left[\frac{b^5}{20} - \frac{b^4 r_1}{4} + \frac{b^3 r_1^2}{2} - \frac{b^2 r_1^3}{2} + \frac{b r_1^4}{4} - \frac{r_1^5}{20} - \frac{a b^4}{8} + \frac{a b^3 r_1}{2} \right. \\
&\quad - \frac{3 a b^2 r_1^2}{4} + \frac{a b r_1^3}{2} - \frac{a r_1^4}{8} + \frac{a b^3 r_1}{3} - a b^2 r_1^2 + a b r_1^3 - \frac{a r_1^4}{3} \\
&\quad + \frac{b^3 r_1^2}{6} - \frac{b^2 r_1^3}{2} + \frac{b r_1^4}{2} - \frac{r_1^5}{6} + \frac{a^2 b^3}{4} - \frac{3 a^2 b^2 r_1}{4} + \frac{3 a^2 b r_1^2}{4} - \frac{a^2 r_1^3}{4} \\
&\quad - \frac{b r_1^4}{12} + \frac{r_1^5}{12} + \frac{a^2 b r_1^2}{4} - \frac{a^2 r_1^3}{4} - \frac{a b^2 r_1^2}{4} + \frac{a b r_1^3}{2} - \frac{a r_1^4}{4} - \frac{a^2 b^2 r_1}{2} \\
&\quad + a^2 b r_1^2 - \frac{a^2 r_1^3}{2} + \frac{a^3 b r_1}{3} - \frac{a^3 r_1^2}{3} - \frac{a^3 b^2}{4} + \frac{a^3 b r_1}{2} - \frac{a^3 r_1^2}{4} + \frac{b^2 r_1^3}{2} \\
&\quad + \frac{a^4 b}{8} - \frac{a^4 r_1}{8} + \frac{b^5}{8} - \frac{b^4 r_1}{8} - \frac{b^5}{4} + \frac{b^4 r_1}{2} - \frac{b^3 r_1^2}{4} - \frac{b^4 r_1}{3} - b^3 r_1^2 \\
&\quad + \frac{b^3 r_1^2}{3} + \frac{b^5}{4} - \frac{3 b^4 r_1}{4} + \frac{3 b^3 r_1^2}{4} - \frac{b^2 r_1^3}{4} + \frac{b^4 r_1}{2} + \frac{b^3 r_1^2}{4} - \frac{b^2 r_1^3}{4} \\
&\quad - \frac{b^5}{8} + \frac{b^4 r_1}{2} - \frac{3 b^3 r_1^2}{4} + \frac{b^2 r_1^3}{2} - \frac{b r_1^4}{8} - \frac{b^4 r_1}{3} + b^3 r_1^2 - b^2 r_1^3 \\
&\quad + \frac{b r_1^4}{3} - \frac{b^3 r_1^2}{4} + \frac{b^2 r_1^3}{2} - \frac{b r_1^4}{4} - \frac{a^5}{20} - \frac{a^4 r_1}{4} - \frac{a^3 r_1^2}{2} - \frac{a^2 r_1^3}{2} - \frac{a r_1^4}{4} \\
&\quad - \frac{r_1^5}{20} + \frac{a^5}{8} + \frac{a^4 r_1}{2} + \frac{3 a^3 r_1^2}{4} + \frac{a^2 r_1^3}{2} + \frac{a r_1^4}{8} - \frac{a^4 r_1}{3} - a^3 r_1^2 \\
&\quad - a^2 r_1^3 - \frac{a r_1^4}{3} - \frac{a^3 r_1^2}{6} - \frac{a^2 r_1^3}{2} - \frac{a r_1^4}{2} - \frac{r_1^5}{6} - \frac{a^5}{4} - \frac{3 a^4 r_1}{4} - \frac{3 a^3 r_1^2}{4} \\
&\quad - \frac{a^2 r_1^3}{4} + \frac{a r_1^4}{12} + \frac{r_1^5}{12} - \frac{a^3 r_1^2}{4} - \frac{a^2 r_1^3}{4} + \frac{a^3 r_1^2}{4} + \frac{a^2 r_1^3}{2} + \frac{a r_1^4}{4}
\end{aligned}$$

$$\begin{aligned}
& + \frac{a^4 r_1}{2} + a^3 r_1^2 + \frac{a^2 r_1^3}{2} - \frac{a^4 r_1}{3} - \frac{a^3 r_1^2}{3} + \frac{a^5}{4} + \frac{a^4 r_1}{2} + \frac{a^3 r_1^2}{4} - \frac{a^5}{8} \\
& - \frac{a^4 r_1}{8} - \frac{ab^4}{8} - \frac{b^4 r_1}{8} + \frac{a^2 b^3}{4} + \frac{ab^3 r_1}{2} + \frac{b^3 r_1^2}{4} + \frac{ab^3 r_1}{3} + \frac{b^3 r_1^2}{3} \\
& - \frac{a^3 b^2}{4} - \frac{3a^2 b^2 r_1}{4} - \frac{3ab^2 r_1^2}{4} - \frac{b^2 r_1^3}{4} - \frac{a^2 b^2 r_1}{2} - ab^2 r_1^2 - \frac{b^2 r_1^3}{2} \\
& - \frac{ab^2 r_1^2}{4} - \frac{b^2 r_1^3}{4} + \frac{a^4}{8} + \frac{abr_1^3}{2} + \frac{3a^2 br_1^2}{4} + \frac{abr_1^3}{2} + \frac{br_1^4}{8} + \frac{a^3 br_1}{3} \\
& + a^2 br_1^2 + abr_1^3 + \frac{br_1^4}{3} + \frac{a^2 br_1^2}{4} + \frac{abr_1^3}{2} + \frac{br_1^4}{4} \Big] dr_1 dG \\
= & \int \left[\frac{b^5}{20} - \frac{5}{12} b^4 r_1 + \frac{4}{3} b^3 r_1^2 - 2b^2 r_1^3 + \frac{4}{3} br_1^4 - \frac{4}{15} r_1^5 - \frac{ab^4}{4} + \frac{5}{3} ab^3 r_1 \right. \\
& - 4ab^2 r_1^2 + 4abr_1^3 - \frac{4}{3} ar_1^4 + \frac{a^2 b^3}{2} - \frac{5a^2 b^2 r_1}{2} + 4a^2 br_1^2 - 2a^2 r_1^3 \\
& \left. + \frac{5}{3} a^3 br_1 - \frac{4}{3} a^3 r_1^2 - \frac{a^3 b^2}{2} + \frac{a^4 b}{4} - \frac{5a^4 r_1}{12} - \frac{a^5}{20} \right] dr_1 dG. \\
= & \int \left[\left(\frac{b^5}{20} - \frac{b^4 a}{4} + \frac{b^3 a^2}{2} - \frac{b^2 a^3}{2} + \frac{ba^4}{4} - \frac{a^5}{20} \right) + \right. \\
& r_1 \left(-\frac{5}{12} b^4 + \frac{5}{3} b^3 a - \frac{5}{2} a^2 b^2 + \frac{5}{3} ba^3 - \frac{5}{12} a^4 \right) + \\
& r_1^2 \left(\frac{4}{3} b^3 - 4b^2 a + 4ba^2 - \frac{4}{3} a^3 \right) + r_1^4 \left(\frac{4}{3} b - \frac{4}{3} a \right) + \\
& \left. r_1^3 \left(-2b^2 + 4ab - 2a^2 \right) - \frac{4}{15} r_1^5 \right] dr_1 dG.
\end{aligned}$$

$$= \int \left[\int_0^{\frac{\Delta}{2}} \left(\frac{\Delta^5}{20} - \frac{5}{12} \Delta^4 r_1 + \frac{4}{3} \Delta^3 r_1^2 + \frac{4}{3} \Delta r_1^4 - 2 \Delta^2 r_1^3 - \frac{4}{15} r_1^5 \right) dr_1 \right] dG$$

$$= \int \left(\frac{\Delta^5 r_1}{20} - \frac{5}{12} \frac{\Delta^4 r_1^2}{2} + \frac{4}{3} \frac{\Delta^3 r_1^3}{3} + \frac{4}{3} \frac{\Delta r_1^5}{5} - \frac{2 \Delta^2 r_1^4}{4} - \frac{4}{15} \frac{r_1^6}{6} \right) \Bigg|_0^{\frac{\Delta}{2}} dG$$

$$= \int \left(\frac{\Delta^6}{40} - \frac{5}{24} \frac{\Delta^6}{4} + \frac{4}{9} \frac{\Delta^6}{8} + \frac{4}{15} \frac{\Delta^6}{32} - \frac{1}{2} \frac{\Delta^6}{16} - \frac{2}{45} \frac{\Delta^6}{64} \right) dG$$

$$= \int \left(\frac{\Delta^6}{40} - \frac{5 \Delta^6}{96} + \frac{\Delta^6}{18} + \frac{\Delta^6}{120} - \frac{\Delta^6}{32} - \frac{\Delta^6}{1440} \right) dG$$

$$= \frac{7}{1440} \int_{\ln K \neq \phi} \Delta^6 dG$$

From (4.5) we get

$$\begin{aligned} \int_X r dB_1 dB_2 &= \left(\frac{1}{720} + \frac{7}{1440} + \frac{1}{720} \right) \int_{\ln K \neq \phi} \Delta^6 dG \\ &= \frac{11}{1440} \int_{\ln K \neq \phi} \Delta^6 dG . \end{aligned}$$

Q.E.D.

4.2.3 Remark : We see that when $r = 0$ will not really give a circle, but measure of the set of circles whose radii are 0 is equal to 0.

4.2.4 Corollary : Let K be a convex curve, the set X and all hypothesis of this corollary are the same as in theorem 4.2.2. Then by using density in (4.3)

$$\int_X dB_1 dB_2 = \frac{17}{240} \int_{\ln K \neq \emptyset} \Delta^5 dG$$

Proof : We see that all of cases and limits of integration are the same as theorem 4.2.2

So by integration we get

$$\int_X dB_1 dB_2 = \frac{17}{240} \int_{\ln K \neq \emptyset} \Delta^5 dG$$

Q.E.D.

Theorem:

4.2.5 \wedge Let K be a fixed convex curve and X be the set of pairs of circles B_1 and B_2 such that $B_2 \subseteq B_1$ and their centers are contained in K . Assume that B_1, B_2 not contain K and let l be the straight line through the centers of B_1 and B_2 and Δ be the length of the chord determined by l and K . Then by using density in (4.3)

$$\int_X dB_1 dB_2 = \frac{97}{960} \int_{\ln K \neq \emptyset} \Delta^5 dG .$$

PROOF: Choose a fixed rectangular coordinate system so that the convex curve K lies in the first quadrant.

Let B_1, B_2 be a pair of distinct circles whose centers at (x_1, y_1) and (x_2, y_2) and radii of B_1 and B_2 is r_1 and r_2 respectively. Let b and a signify the values of t corresponding to the end points of \sphericalangle , so that $b - a = \sphericalangle$

To prove this, we have 3 possible cases.

case 1 Let $X_1 = \{(B_1, B_2) \in X / \text{exactly one of the intersection points between } B_1 \text{ and } l \text{ is contained in } K \text{ and the other has } t \text{ coordinate} < a\}$

In this case, since $B_2 \leq B_1$ we see that the radius r_2 of B_2 can vary from 0 to r_1 and we can divide it into 2 subcases :

subcase 1 Let $X_{1,1} = \{(B_1, B_2) \in X_1 / 0 \leq r_2 \leq r_1 - t_1 + a\}$

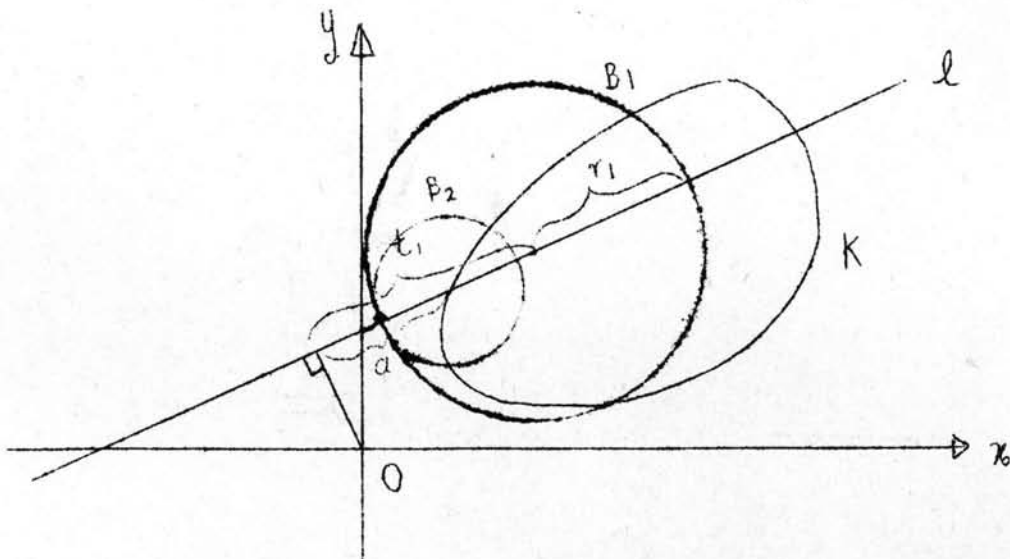

Figure 31

In this subcase, if we

fix t_1, r_1, r_2, l then t_2 varies from a to $t_1 + r_1 - r_2$

fix t_1, r_1, l then r_2 varies from 0 to $r_1 - t_1 + a$

fix r_1, l then t_1 varies from a to $a + r_1$

fix l then r_1 varies from 0 to ∞

subcases 2 Let $X_{12} = \left\{ (B_1, B_2) \in X_1 / r_1 - t_1 + a < r_2 \leq r_1 \right\}$

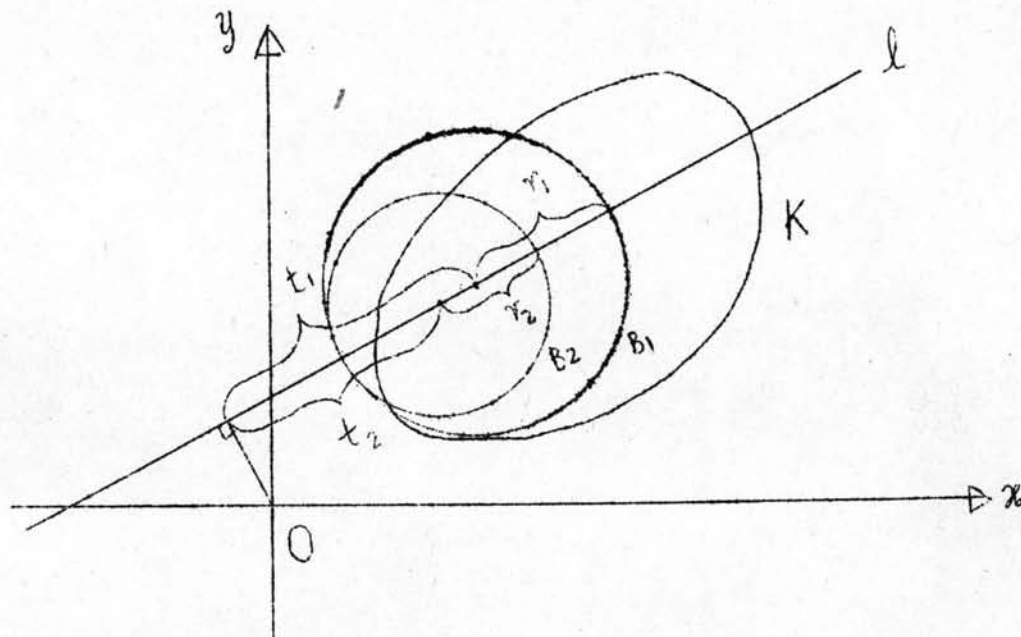

Figure 32

In this subcase, if we

fix t_1, r_1, r_2, l then t_2 varies from $t_1 - r_1 + r_2$ to $t_1 + r_1 - r_2$

fix t_1, r_1, l then r_2 varies from $r_1 - t_1 + a$ to r_1

fix r_1, l then t_1 varies from a to $a + r_1$

fix l then r_1 varies from 0 to ∞

We see that $X_1 = X_{11} \cup X_{12}$

and $X_{11} \cap X_{12} = \emptyset$

Then

$$\int_{X_1} dB_1 dB_2 = \int_{X_{11}} dB_1 dB_2 + \int_{X_{12}} dB_1 dB_2$$



case 2 Let $X_2 = \{ (B_1, B_2) \in X \mid \text{both of the intersection points between } B_1 \text{ and } l \text{ are contained in } K \}$

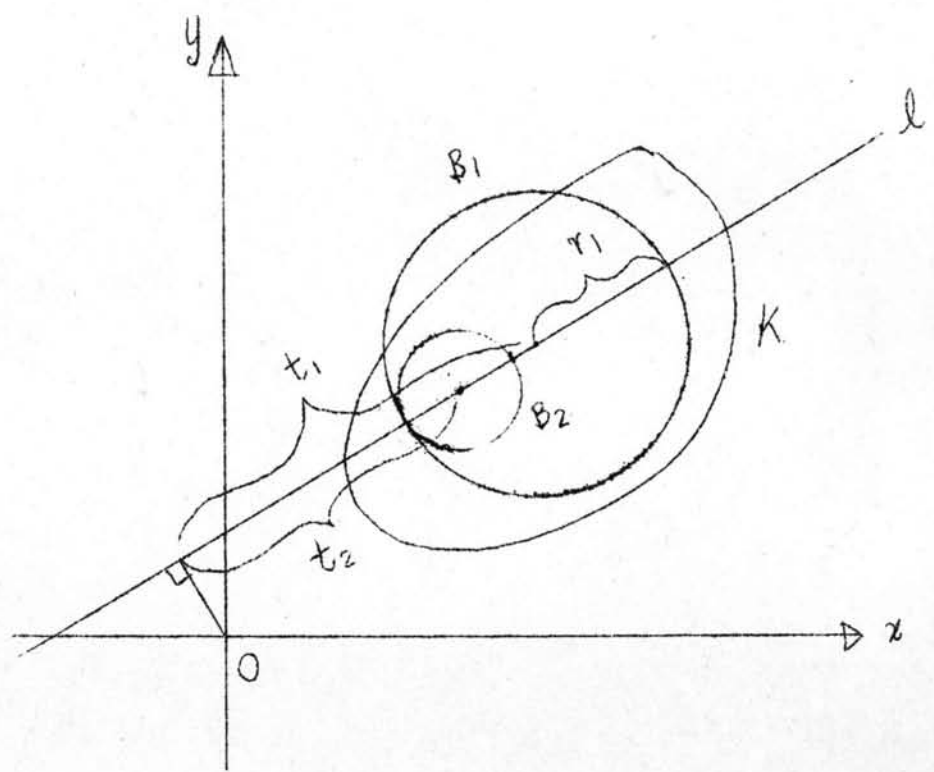

Figure 33

In this case, if we

- | | |
|------------------------|---|
| fix t_1, r_1, r_2, l | then t_2 varies from $t_1 - r_1 + r_2$ to $t_1 + r_1 - r_2$ |
| fix t_1, r_1, l | then r_2 varies from 0 to r_1 |
| fix r_1, l | then t_1 varies from $a + r_1$ to $b - r_1$ |
| fix l | then r_1 varies from 0 to $\frac{d}{2}$. |

case 3 Let $X_3 = \left\{ (B_1, B_2) \in X \mid \text{exactly one of the intersection points between } B_1 \text{ and } l \text{ is contained in } K \text{ and the other has } t \text{ coordinate } > b \right\}$.

Also, we can divide this case into 2 subcases.

subcase 1 Let $X_{3,1} = \left\{ (B_1, B_2) \in X_3 \mid 0 \leq r_2 \leq r_1 - b + t_1 \right\}$

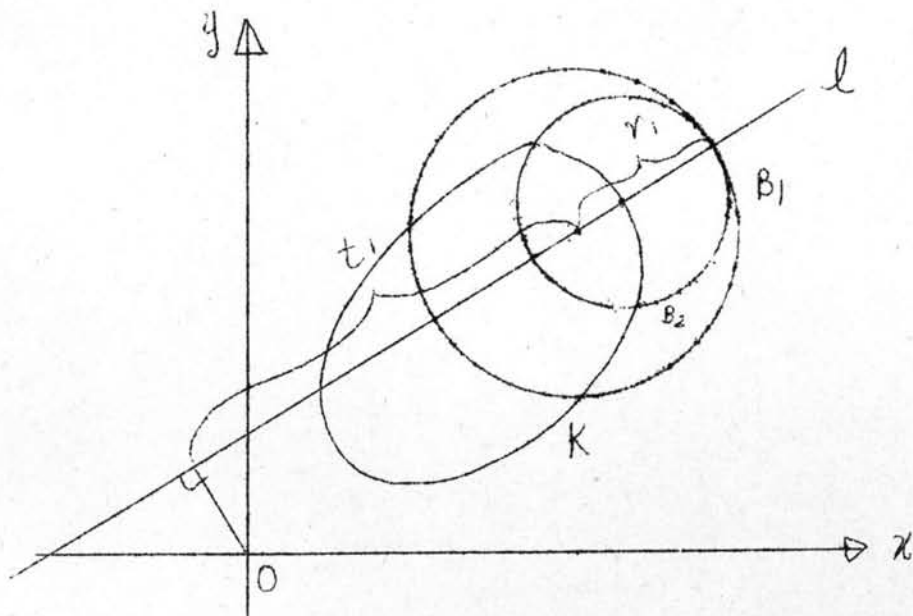

Figure 34

in this subcase, if we

fix $t_1, r_1, r_2, 1$ then t_2 varies from $t_1 - r_1 + r_2$ to b

fix $t_1, r_1, 1$ then r_2 varies from 0 to $r_1 - b + t_1$

fix $r_1, 1$ then t_1 varies from $b - r_1$ to b

fix 1 then r_1 varies from 0 to ∞

subcase 2 Let $X_{32} = \left\{ (B_1, B_2) \in X_3 / r_1 - b + t_1 \leq r_2 \leq r_1 \right\}$

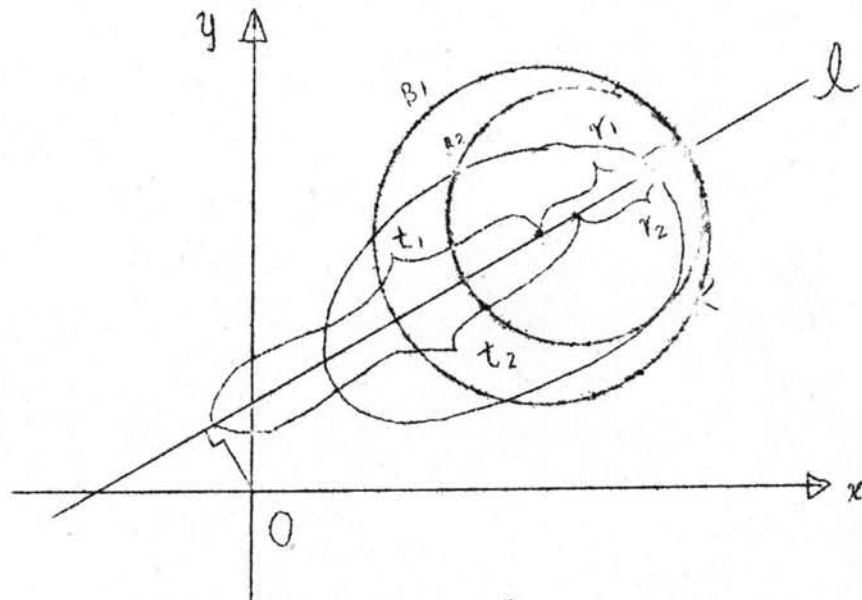

Figure 35

In this subcase, if we

fix $t_1, r_1, r_2, 1$ then t_2 varies from $t_1 - r_1 + r_2$ to $t_1 + r_1 - r_2$

fix $t_1, r_1, 1$ then r_2 varies from $r_1 - b + t_1$ to r_1

fix $r_1, 1$ then t_1 varies from $b - r_1$ to b

fix 1 then r_1 varies from 0 to ∞

We see that

$$X_3 = X_{3_1} \cup X_{3_2}$$

$$\text{and } X_{3_1} \cap X_{3_2} = \emptyset$$

$$\text{Then } \int_{X_3} dB_1 dB_2 = \int_{X_{3_1}} dB_1 dB_2 + \int_{X_{3_2}} dB_1 dB_2$$

From all of these cases, we have

$$X = X_1 \cup X_2 \cup X_3 \quad \text{such that}$$

$$X_1 \cap X_2 \cap X_3 = \emptyset, \quad X_1 \cap X_2 = \emptyset$$

$$X_1 \cap X_3 = \emptyset, \quad X_2 \cap X_3 = \emptyset$$

therefore

$$\int_X dB_1 dB_2 = \int_{X_1} dB_1 dB_2 + \int_{X_2} dB_1 dB_2 + \int_{X_3} dB_1 dB_2$$

First of all, we will find

$$\int_{X_1} dB_1 dB_2 = \int_{X_1} dx_1 dy_1 dr_1 dx_2 dy_2 dr_2$$

From (4.3) we have

$$\int_{X_1} dB_1 dB_2 = \int_{X_1} |t_2 - t_1| dG dt_1 dt_2 dr_1 dr_2$$

$$\begin{aligned}
&= \int \left[\int_a^{t_1} (t_1 - t_2) dt_2 + \int_{t_1}^{t_1+r_1-r_2} (t_2 - t_1) dt_2 \right] dr_2 dt_1 dr_1 dG \\
&+ \int \left[\int_{t_1-r_1+r_2}^{t_1} (t_1 - t_2) dt_2 + \int_{t_1}^{t_1+r_1-r_2} (t_2 - t_1) dt_2 \right] dr_2 dt_1 dr_1 dG \\
&= \int \left[t_1 t_2 - \frac{t_2^2}{2} \Big|_a^{t_1} + \frac{t_2^2}{2} - t_1 t_2 \Big|_{t_1}^{t_1+r_1-r_2} \right] dr_2 dt_1 dr_1 dG + \\
&\int \left[t_1 t_2 - \frac{t_2^2}{2} \Big|_{t_1-r_1+r_2}^{t_1} + \frac{t_2^2}{2} - t_1 t_2 \Big|_{t_1}^{t_1+r_1-r_2} \right] dr_2 dt_1 dr_1 dG \\
&= \int \left[t_1^2 - \frac{t_1^2}{2} - a t_1 + \frac{a^2}{2} + \frac{(t_1+r_1-r_2)^2}{2} - t_1(t_1+r_1-r_2) - \frac{t_1^2}{2} + t_1^2 \right] \\
&\qquad\qquad\qquad dr_2 dt_1 dr_1 dG \\
&+ \int \left[t_1^2 - \frac{t_1^2}{2} - t_1(t_1 - r_1 + r_2) + \frac{(t_1 - r_1 + r_2)^2}{2} + \frac{(t_1 + r_1 - r_2)^2}{2} \right. \\
&\quad \left. - t_1(t_1 + r_1 - r_2) - \frac{t_1^2}{2} + t_1^2 \right] dr_2 dt_1 dr_1 dG \\
&= \int \left[\int_0^{r_1-t_1+a} \left(-a t_1 + \frac{a^2}{2} + \frac{t_1^2}{2} + \frac{r_1^2}{2} + \frac{r_2^2}{2} - r_1 r_2 \right) dr_2 \right] dt_1 dr_1 dG + \\
&\int \left[\int_{r_1-t_1+a}^{r_1} (r_1^2 + r_2^2 - 2r_1 r_2) dr_2 \right] dt_1 dr_1 dG.
\end{aligned}$$

$$\begin{aligned}
&= \int \left[-at_1 r_2 + \frac{a^2 r_2}{2} + \frac{t_1^2 r_2}{2} + \frac{r_1^2 r_2}{2} + \frac{r_2^3}{6} - \frac{r_1 r_2^2}{2} \right]_{0}^{r_1 - t_1 + a} \\
&\quad dt_1 dr_1 dG + \\
&\int \left[r_1^2 r_2 + \frac{r_2^3}{3} - \frac{2r_1 r_2^2}{2} \right]_{r_1 - t_1 + a}^{r_1} dt_1 dr_1 dG \\
&= \int \left[-at_1(r_1 - t_1 + a) + \frac{a^2}{2}(r_1 - t_1 + a) + \frac{t_1^2}{2}(r_1 - t_1 + a) + \frac{r_1^2}{2}(r_1 - t_1 + a) \right. \\
&\quad \left. + \frac{(r_1 - t_1 + a)^3}{6} - \frac{r_1}{2}(r_1 - t_1 + a)^2 \right] dt_1 dr_1 dG + \\
&\int \left[r_1^3 + \frac{r_1^3}{3} - r_1^3 - r_1^2(r_1 - t_1 + a) - \frac{(r_1 - t_1 + a)^3}{3} \right. \\
&\quad \left. + r_1(r_1 - t_1 + a)^2 \right] dt_1 dr_1 dG. \\
&= \int \left[\int_a^{a+r_1} \left(-a^2 t_1 + \frac{a^3}{3} - \frac{t_1^3}{3} + at_1^2 + \frac{r_1^3}{6} + \frac{t_1^2 r_1}{2} - at_1 r_1 + \frac{a^2 r_1}{2} \right) dt_1 \right] \\
&\quad dr_1 dG \\
&= \int \left[-\frac{a^2 t_1^2}{2} + \frac{a^3 t_1}{3} - \frac{t_1^4}{12} + \frac{at_1^3}{3} + \frac{r_1^3 t_1}{6} + \frac{t_1^3 r_1}{6} - \frac{at_1^2 r_1}{2} \right. \\
&\quad \left. + \frac{a^2 r_1 t_1}{2} \right]_{a}^{a+r_1} dr_1 dG
\end{aligned}$$

$$\begin{aligned}
&= \int \left[-\frac{a^2}{2}(a+r_1)^2 + \frac{a^3}{3}(a+r_1) - \frac{(a+r_1)^4}{12} + \frac{a}{3}(a+r_1)^3 + \frac{r_1^3}{6}(a+r_1) + \frac{r_1}{6}(a+r_1)^3 \right. \\
&\quad - \frac{ar_1}{2}(a+r_1)^2 + \frac{a^2 r_1}{2}(a+r_1) + \frac{a^4}{2} - \frac{a^4}{3} + \frac{a^4}{12} - \frac{a^4}{3} - \frac{ar_1^3}{6} - \frac{a^3 r_1}{6} + \frac{a^3 r_1}{2} \\
&\quad \left. - \frac{a^3 r_1}{2} \right] dr_1 dG \\
&= \int \left[\int_0^{\Delta} \left(\frac{r_1^4}{4} \right) dr_1 \right] dG \\
&= \int \left. \frac{r_1^5}{20} \right|_0^{\Delta} dG \\
&= \frac{1}{20} \int \Delta^5 dG
\end{aligned}$$

Therefore

$$\int_{X_1} dB_1 dB_2 = \frac{1}{20} \int \Delta^5 dG$$

Next, we will find

$$\begin{aligned}
\int_{X_2} dB_1 dB_2 &= \int \left[\int_{t_1 - r_1 + r_2}^{t_1 + r_1 - r_2} |t_2 - t_1| dt_2 \right] dr_2 dt_1 dr_1 dG \\
&= \int \left[\int_{t_1 - r_1 + r_2}^{t_1} (t_1 - t_2) dt_2 + \int_{t_1}^{t_1 + r_1 - r_2} (t_2 - t_1) dt_2 \right] dr_2 dt_1 dr_1 dG \\
&= \int \left[\int_0^{r_1} (r_1^2 + r_2^2 - 2r_1 r_2) dr_2 \right] dt_1 dr_1 dG
\end{aligned}$$

$$\begin{aligned}
&= \int \left[r_1^2 r_2 + \frac{r_2^3}{3} - \frac{2r_1 r_2^2}{2} \right]_{0}^{\gamma_1} dt_1 dr_1 dG \\
&= \int \left[\int_{a+\gamma_1}^{b-\gamma_1} \left(\frac{r_1^3}{3} \right) dt_1 \right] dr_1 dG \\
&= \int \left[\frac{r_1^3 t_1}{3} \right]_{a+\gamma_1}^{b-\gamma_1} dr_1 dG \\
&= \int \left[\frac{r_1^3}{3} (b-r_1-a-r_1) \right] dr_1 dG \\
&= \int \left[\int_0^{\Delta/2} \left(\frac{\Delta r_1^3}{3} - \frac{2r_1^4}{3} \right) dr_1 \right] dG \\
&= \int \left[\frac{\Delta r_1^4}{12} - \frac{2r_1^5}{15} \right]_0^{\Delta/2} dG \\
&= \int \left(\frac{\Delta^5}{12 \times 16} - \frac{2\Delta^5}{15 \times 32} \right) dG = \frac{1}{960} \int \Delta^5 dG
\end{aligned}$$

at last, we will find

$$\begin{aligned}
\int_{X_3} dB_1 dB_2 &= \int \left[\int_{t_1-\gamma_1+\gamma_2}^b |t_2-t_1| dt_2 \right] dr_2 dt_1 dr_1 dG + \\
&\int \left[\int_{t_1-\gamma_1+\gamma_2}^{t_1+\gamma_1-\gamma_2} |t_2-t_1| dt_2 \right] dr_2 dt_1 dr_1 dG
\end{aligned}$$

$$\begin{aligned}
&= \int \left[t_1 t_2 - \frac{t_2^2}{2} \right]_{t_1 - r_1 + r_2}^{t_1} + \frac{t_2^2}{2} - t_1 t_2 \left[\right]_{t_1}^b dr_2 dt_1 dr_1 dG + \\
&\int \left[t_1 t_2 - \frac{t_2^2}{2} \right]_{t_1 - r_1 + r_2}^{t_1} + \frac{t_2^2}{2} - t_1 t_2 \left[\right]_{t_1}^{t_1 + r_1 - r_2} dr_2 dt_1 dr_1 dG \\
&= \int \left[t_1^2 - \frac{t_1^2}{2} - t_1(t_1 - r_1 + r_2) + \frac{(t_1 - r_1 + r_2)^2}{2} + \frac{b^2}{2} - bt_1 - \frac{t_1^2}{2} \right. \\
&\quad \left. + t_1^2 \right] dr_2 dt_1 dr_1 dG \\
&+ \int \left[t_1^2 - \frac{t_1^2}{2} - t_1(t_1 - r_1 + r_2) + \frac{(t_1 - r_1 + r_2)^2}{2} + \frac{(t_1 + r_1 - r_2)^2}{2} \right. \\
&\quad \left. - t_1(t_1 + r_1 - r_2) - \frac{t_1^2}{2} + t_1^2 \right] dr_2 dt_1 dr_1 dG \\
&= \int \left[\int_{r_1 - b + t_1}^{r_1 - b + t_1} \left(\frac{t_1^2}{2} + \frac{r_1^2}{2} + \frac{r_2^2}{2} - r_1 r_2 + \frac{b^2}{2} - bt_1 \right) dr_2 \right] dt_1 dr_1 dG + \\
&\int \left[\int_{r_1 - b - t_1}^{r_1} (r_1^2 + r_2^2 - 2r_1 r_2) dr_2 \right] dt_1 dr_1 dG \\
&= \int \left[\frac{t_1^2 r_2}{2} + \frac{r_1^2 r_2}{2} + \frac{r_2^3}{6} - \frac{r_1 r_2^2}{2} + \frac{b^2 r_2}{2} - bt_1 r_2 \right]_{r_1 - b + t_1}^{r_1 - b + t_1} \\
&\quad dt_1 dr_1 dG + \\
&\int \left[r_1^2 r_2 + \frac{r_2^3}{3} - \frac{2r_1 r_2^2}{2} \right]_{r_1 - b + t_1}^{r_1} dt_1 dr_1 dG
\end{aligned}$$

$$\begin{aligned}
&= \int \left[\frac{t_1^2}{2} (r_1 - b + t_1) + \frac{r_1^2}{2} (r_1 - b + t_1) + \frac{(r_1 - b + t_1)^3}{6} - \frac{r_1}{2} (r_1 - b + t_1)^2 \right. \\
&\quad + \frac{b^2}{2} (r_1 - b + t_1) - bt_1 (r_1 - b + t_1) + r_1^3 + \frac{r_1^3}{3} - r_1^3 - r_1^2 (r_1 - b + t_1) \\
&\quad \left. - \frac{(r_1 - b + t_1)^3}{3} + r_1 (r_1 - b + t_1)^2 \right] dt_1 dr_1 dG. \\
&= \int \left[\int_{b-r_1}^b \left(\frac{t_1^3}{3} + \frac{r_1^3}{6} - \frac{b^3}{3} - bt_1 r_1 + \frac{t_1^2 r_1}{2} + \frac{b^2 r_1}{2} + b^2 t_1 - bt_1^2 \right) dt_1 \right] dr_1 dG \\
&= \int \left[\frac{t_1^4}{12} + \frac{r_1^3 t_1}{6} - \frac{b^3 t_1}{3} - \frac{bt_1^2 r_1}{2} + \frac{t_1^3 r_1}{6} + \frac{b^2 r_1 t_1}{2} + \frac{b^2 t_1^2}{2} \right. \\
&\quad \left. - \frac{bt_1^3}{3} \right]_{b-r_1}^b dr_1 dG \\
&= \int \left[\frac{b^4}{12} + \frac{br_1^3}{6} - \frac{b^4}{3} - \frac{b^3 r_1}{2} + \frac{b^3 r_1}{6} + \frac{b^3 r_1}{2} + \frac{b^4}{2} - \frac{b^4}{3} - \right. \\
&\quad \left. \frac{(b-r_1)^4}{12} - \frac{r_1^3}{6} (b-r_1) + \frac{b^3}{3} (b-r_1) + \frac{br_1}{2} (b-r_1)^2 - \frac{r_1}{6} (b-r_1)^3 - \frac{b^2 r_1}{2} (b-r_1) - \right. \\
&\quad \left. - \frac{b^2}{2} (b-r_1)^2 + \frac{b}{3} (b-r_1)^3 \right] dr_1 dG. \\
&= \int \left[\int_0^b \frac{r_1^4}{4} dr_1 \right] dG \\
&= \int \left[\frac{r_1^5}{20} \Big|_0^b \right] dG \\
&= \frac{1}{20} \int b^5 dG \\
&\quad \ln K \neq \phi
\end{aligned}$$

Hence

$$\begin{aligned} \int_X dB_1 dB_2 &= \left(\frac{1}{20} + \frac{1}{960} + \frac{1}{20} \right) \int_{\ln K \neq \phi} \Delta^5 dG \\ &= \frac{97}{960} \int_{\ln K \neq \phi} \Delta^5 dG \end{aligned}$$

Q.E.D.

Section 4.3 Integral Geometry Over Sets of Pairs of Kinematics.

4.3.1 Density for sets of Pairs of Kinematics.

A pair of kinematics $K_1(x_1, y_1, \varphi_1)$, $K_2(x_2, y_2, \varphi_2)$ may be determined by the six coordinates $x_1, y_1, \varphi_1, x_2, y_2, \varphi_2$. It may also be determined by the coordinate of the straight lines G_1 and G_2 determined by K_1 and K_2 together with the directed distances t_1, t_2 from $(x_1, y_1), (x_2, y_2)$ to the foot of the perpendicular drawn from origin O to G_1 and G_2 respectively. We want to express the product $dK_1 dK_2 = dx_1 dy_1 d\varphi_1 dx_2 dy_2 d\varphi_2$ by means of the coordinates of straight lines G_1, G_2 and t_1, t_2 .

From (3.41) we have

$$dK = \vec{dG} dt$$

therefore

$$(4.6) \quad dK_1 dK_2 = \vec{dG}_1 dt_1 \vec{dG}_2 dt_2$$

4.3.2 Theorem : Let K_0 be a convex curve of area F and X be a set of pairs of segments K_1 and K_2 of length l_1 and l_2 which intersect each other inside K_0 and intersect the curve K_0 . Then

$$\int_X dK_1 dK_2 = 16 \pi F l_1 l_2$$

Proof : Choose a fixed rectangular coordinate system so that the convex curve K_0 lies in the first quadrant.

Let (x_1, y_1, φ_1) and (x_2, y_2, φ_2) be the coordinates of K_1 and K_2 respectively. Let $P(x, y)$ be the point of intersection between K_1 and K_2 .

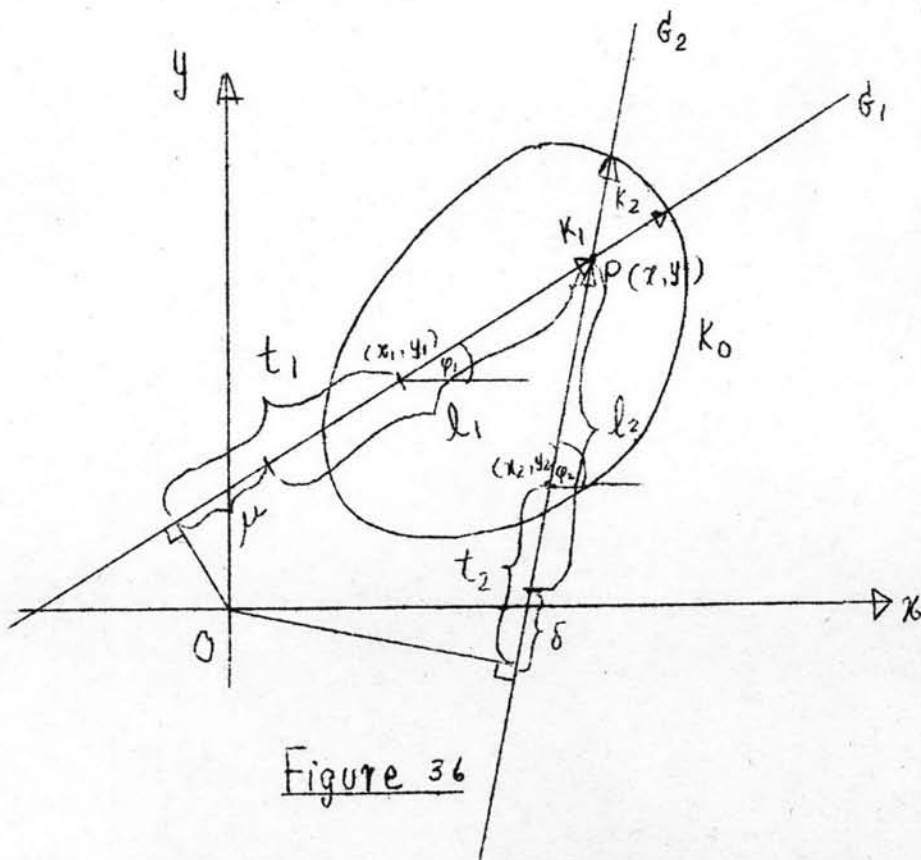

Figure 36

From (4.6) we have

$$\int_X dK_1 dK_2 = \int_X \vec{dG}_1 dt_1 \vec{dG}_2 dt_2$$

and each non-oriented line carries two oriented ones, we obtain

$$\begin{aligned} \int_X dK_1 dK_2 &= 4 \int_X dG_1 dt_1 dG_2 dt_2 \\ &= 4 \int \left[\int_{\mu}^{\mu+l_1} dt_1 \right] dt_2 dG_1 dG_2 \end{aligned}$$

where μ depend on G_1 and shown in Figure 36.

therefore

$$\int_X dK_1 dK_2 = 4 \int \left[\int_{\delta}^{\delta+l_2} l_1 dt_2 \right] dG_1 dG_2$$

where δ depend on G_2 , we get

$$\int_X dK_1 dK_2 = 4l_1 l_2 \int_{\substack{G_1 n K_0 \neq \phi \\ G_2 n K_0 \neq \phi}} dG_1 dG_2$$

From (3.32) we have

$$dG_1 dG_2 = \left| \sin(\varphi_1 - \varphi_2) \right| d\rho d\varphi_1 d\varphi_2$$

we get

$$\int_X \int_P dK_1 dK_2 = 4l_1 l_2 \int_0^{2\pi} \int_0^{2\pi} \int_{P \in K_0} |\sin(\varphi_1 - \varphi_2)| dP d\varphi_1 d\varphi_2$$

From (3.34) we have

$$\int_{P \in K_0} \int_0^{2\pi} \int_0^{2\pi} |\sin(\varphi_1 - \varphi_2)| d\varphi_1 d\varphi_2 = 2\pi F$$

therefore

$$\begin{aligned} \int_X \int_P dK_1 dK_2 &= 4l_1 l_2 \times 4\pi F \\ &= 16\pi F l_1 l_2 \end{aligned}$$

Q.E.D.